

Emergency Stop Module BG 5924, IP 5924 safemaster

0225592

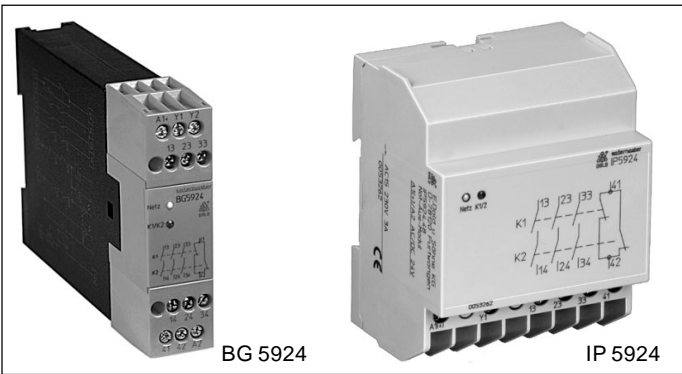

- According to EU directive for machines 98/37/EG
- According to IEC 204-1, DIN EN 60 204-1:1997, DIN VDE 0113-1
- Safety category 4 according to DIN EN 954-1
- Single channel operation
- Output: max. 4 NO contacts
- AC 230 V model with galvanic separation
- For thermal currents to 7 A
- LED indicator for channel 1 / 2 and state of operation
- Line fault detection on ON-button, terminal Y1
- BG 5924 with:
 - Removable terminal strips
 - Wire connection: also 2 x 1,5 mm² stranded ferruled (isolated), DIN 46 228-4 or 2 x 2,5 mm² stranded ferruled DIN 46 228-1/-2/-3
- BG 5924: width 22,5 mm
- IP 5924: width 70 mm

Function diagram

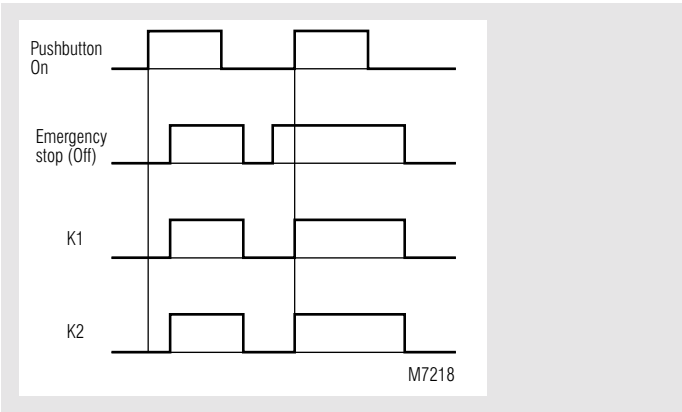

Approvals and marking



Applications

- Protection of people and machines
- Emergency stop circuits on machines

Indicators

LED Netz: on, when supply connected
LED K1/K2: on, when relay K1 and K2 energized

Block diagrams

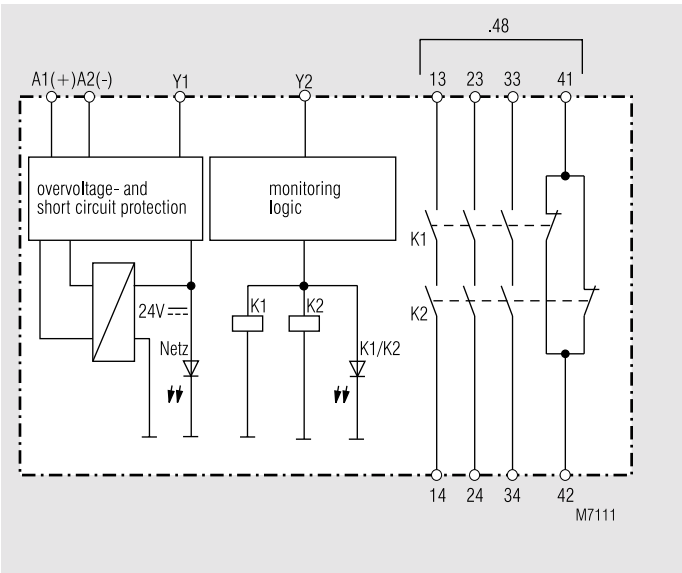

BG 5924.48, BG 5924.48/207, IP 5924.48

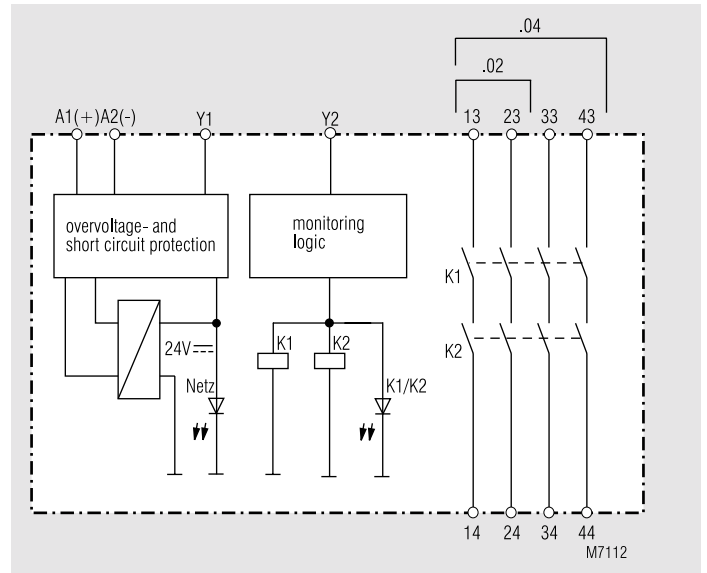

BG 5924.02, BG 5924.02/207, BG 5924.04, BG 5924.04/207, IP 5924.02, IP 5924.04

Circuit diagrams

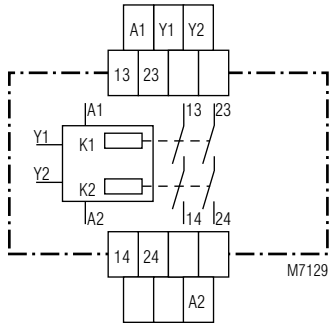

BG 5924.02

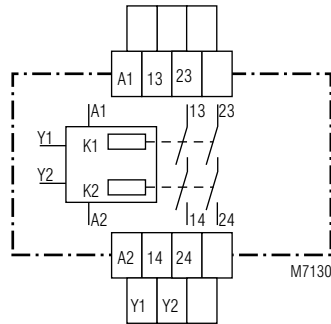

BG 5924.02/207

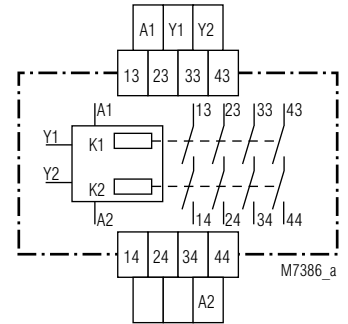

BG 5924.04

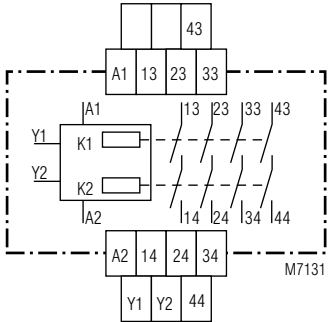

BG 5924.04/207

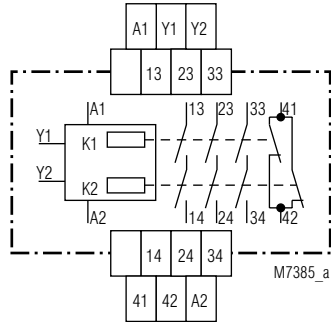

BG 5924.48

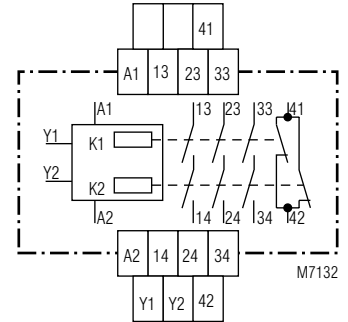

BG 5924.48/207

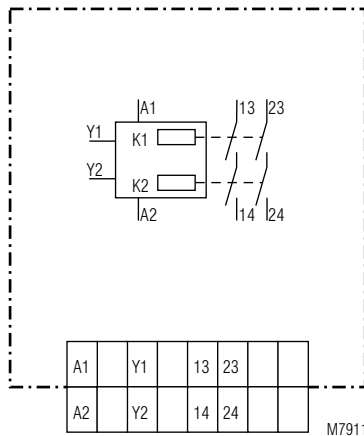

IP 5924.02

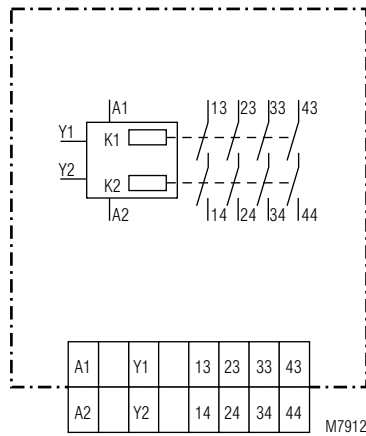

IP 5924.04

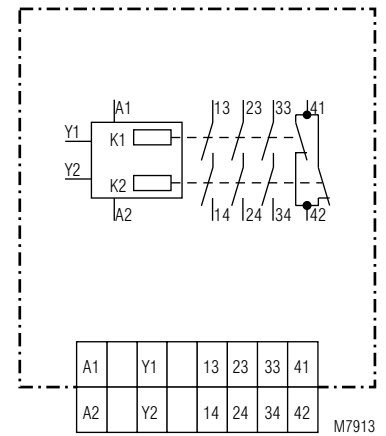

IP 5924.48

Technical data

Input

Nominal voltage U_N :

BG 5924: DC 24 V
AC/DC 24 V
AC 230 V

IP 5924: AC/DC 24, 48 V
AC 110, 230 V

Voltage range:
at 10 % residual ripple: AC 0,8 ... 1,1 U_N
at 48 % residual ripple: DC 0,9 ... 1,1 U_N
DC 0,8 ... 1,1 U_N

Nominal consumption

AC/DC 24 V: DC 1,2 W AC 2 VA
AC 230 V: 3,5 VA

Control voltage on Y1

AC/DC 24 V: typ. DC 23 V
AC 230 V: max. 45 V short pulse

Control current: typ. DC 45 mA

Recovery time: 0,5 s

Output

Contacts

BG 5924.02, IP 5924.02: 2 NO contacts
BG 5924.04, IP 5924.04: 4 NO contacts
BG 5924.48, IP 5924.48: 3 NO, 1 NC contacts

Operate delay: max. 100 ms

Release delay: max. 35 ms

Contact type: positive guided

Thermal current I_{th} :

BG 5924.04/207
terminal 43/44: max. 5 A
BG 5924.48, BG 5924.48/207
terminal 41/42: max. 5 A

max. 7 A / 7 A**

max. 5 A

max. 5 A

** device mounted with distance to next device (see total current limit curve)

Nominal output voltage:

Max. switching current: AC 250 V

Switching capacity AC 8 A $\cos \varphi$ 1 ... 0,7

to AC 15:

3 A / AC 230 V EN 60 947-5-1

for NO contact

2 A / AC 230 V EN 60 947-5-1

for NC contact

Electrical life

to AC 15 at 2 A, AC 230 V: 10^5 switching cycles

10^5 switching cycles EN 60 947-5-1

Permissible operating frequency:

600 switching cycles / h

Short circuit strength

max. fuse rating:
line circuit breaker:

4 A gL EN 60 947-5-1

C 8 A

Mechanical life:

10×10^6 switching cycles

General data

Operating mode:

Continuous operation

Temperature range:

- 15 ... + 55 °C

Technical data

Clearance and creepage distances

overvoltage category / contamination level 4 kV / 2 IEC 60 664-1

EMC

Electrostatic discharge: 8 kV (air) EN 61 000-4-2
 HF irradiation: 10 V / m EN 61 000-4-3
 Fast transients: 2 kV EN 61 000-4-4

Surge voltages between wires for power supply: 1 kV EN 61 000-4-5
 between wire and ground: 2 kV EN 61 000-4-5
 HF wire guided: 10 V EN 61 000-4-6

Interference suppression Degree of protection: Limit value class B EN 55011
 Housing: IP 40 EN 60 529
 Terminals: IP 20 EN 60 529

Housing:

Thermoplastic with V0 behaviour according to UL subject 94

Vibration resistance:

Amplitude 0,35 mm frequency 10 ... 55 Hz, EN 60 068-2-6

Climate resistance:

15 / 055 / 04 EN 60 068-1

Terminal designation:

DIN EN 50 005

Wire connection:

BG 5924: 1 x 4 mm² solid or 1 x 2,5 mm² stranded ferruled (isolated) or 2 x 1,5 mm² stranded ferruled (isolated) DIN 46 228-1/-2/-3/-4 or 2 x 2,5 mm² stranded ferruled DIN 46 228-1/-2/-3

IP 5924: 2 x 1,5 mm² stranded ferruled or 1 x 2,5 mm² stranded ferruled DIN 46 228-1/-2/-3/-4

Wire fixing:

Box terminal with wire protection, removable terminal strips

Mounting:

DIN rail EN 50 022

Weight:

210 g

Dimensions

Width x height x depth:

BG 5924: 22,5 x 84 x 121 mm

IP 5924: 70 x 90 x 59 mm

Standard type

BG 5924.48 AC/DC 24 V

Article number: 0050982
 • Output: 3 NO, 1 NC contacts
 • Nominal voltage U_N : AC/DC 24 V
 • Width: 22,5 mm

IP 5924.48 AC/DC 24 V 50/60 Hz

Article number: 0053262
 • Output: 3 NO, 1 NC contacts
 • Nominal voltage U_N : AC/DC 24 V
 • Width: 70 mm

Variant

BG 5924.__/61: UL-approval
 BG 5924.__/207: special terminal arrangement, (see circuit diagrams), for AC/DC 24 V or AC 230 V

Ordering example for Variant

BG 5924 .48 / _ _ _ AC/DC 24 V
 _____ Nominal voltage
 _____ Variant, if required
 _____ Contact
 _____ Type

IP 5924 .48 AC 230 V
 _____ Nominal voltage
 _____ Contact
 _____ Type

Characteristics

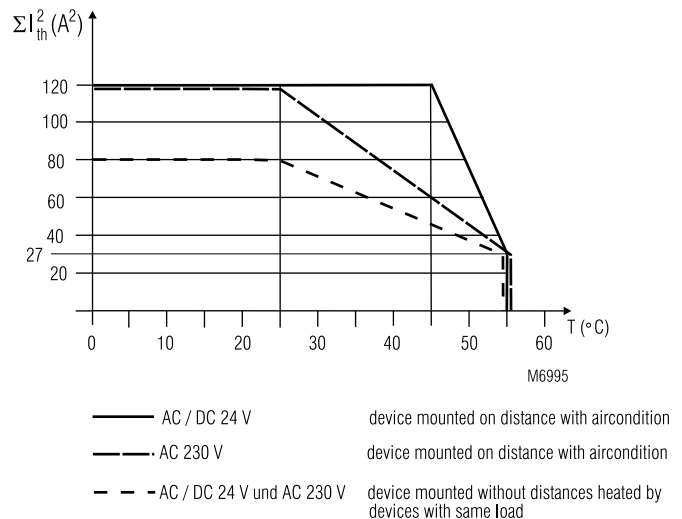

quadratic total current

$$\Sigma I_{th}^2 = I_{th1}^2 + I_{th2}^2 + I_{th3}^2 + I_{th4}^2$$

$I_{th1}, I_{th2}, I_{th3}, I_{th4}$: thermal current I_{th} on contact rows

Total current limit curve

Application examples

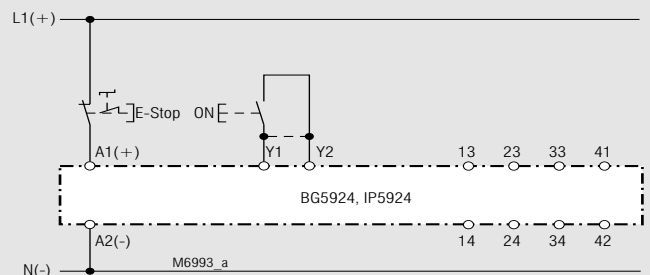

Single channel emergency-stop circuit without feed back loop, with or without automatic restart. For automatic restart terminals Y1-Y2 must be linked. No ON-pushbutton necessary.

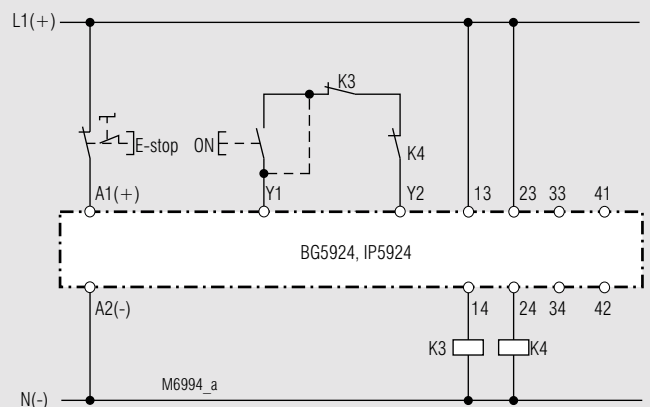

Contact reinforcement by external contactors, 2-channel controlled. For currents > 7 A the output contacts can be reinforced by external contactors. Functioning of the external contactors is monitored by looping the NC contacts into the start circuit (Y1-Y2).

