



## Features

- NPN Silicon Planar Switching Transistor
- Fast switching devices exhibiting short turn-off and low saturation voltage characteristics
- Switching and Linear application DC and VHF Amplifier applications

**RoHS  
Compliant**

## Specification Table

V <sub>CEO</sub> Max. (V)	I <sub>c</sub> Max. (A)	V <sub>CE(sat)</sub> Max. (V) at I <sub>c</sub> = 150mA	t <sub>off</sub> Max. (ns) at I <sub>c</sub> = 150mA	h <sub>FE</sub> Min. at I <sub>c</sub> = 150mA	P <sub>tot</sub> at 25°C (mW)	Package and Pin Out
40	0.8	0.3	60	100	500	TO-18

## Absolute Maximum Ratings

Parameter	Symbol	Rating	Unit
Collector - Emitter Voltage	V <sub>CEO</sub>	40	V
Collector - Base Voltage	V <sub>CBO</sub>	75	
Emitter - Base Voltage	V <sub>EBO</sub>	6	
Collector Current Continuous	I <sub>c</sub>	800	mA
Power Dissipation at T <sub>A</sub> = 25°C Derate above 25°C	P <sub>D</sub>	500 2.28	mW mW / °C
Power Dissipation at T <sub>c</sub> = 25°C Derate above 25°C	P <sub>D</sub>	1.2 6.85	W mW / °C
Operating and Storage Junction Temperature Range	T <sub>J</sub> , T <sub>stg</sub>	-65 to +200	°C

## Electrical Characteristics (T<sub>A</sub> = 25°C unless otherwise specified)

Parameter	Symbol	Test Condition	Value		
			Minimum	Maximum	Unit
Collector - Emitter Voltage	V <sub>CEO</sub>	I <sub>c</sub> = 10mA, I <sub>B</sub> = 0	40	-	V
Collector - Base Voltage	V <sub>CBO</sub>	I <sub>c</sub> = 10μA, I <sub>E</sub> = 0	75	-	
Emitter - Base Voltage	V <sub>EBO</sub>	I <sub>E</sub> = 10μA, I <sub>c</sub> = 0	6	-	
Collector - Cut off Current	I <sub>CBO</sub> I <sub>CEX</sub>	V <sub>CB</sub> = 60V, I <sub>E</sub> = 0 T <sub>A</sub> = 150°C	-	10	nA
		V <sub>CB</sub> = 60V, I <sub>E</sub> = 0 V <sub>CE</sub> = 60V, V <sub>EB</sub> = 3V	-	10 10	μA nA
Emitter - Cut off Current	I <sub>EBO</sub>	V <sub>EB</sub> = 3V, I <sub>c</sub> = 0	-	10	nA
Base - Cut off Current	I <sub>BL</sub>	V <sub>CE</sub> = 60V, V <sub>EB</sub> = 3V	-	20	nA
Collector Emit >35 ter Saturation Voltage	*V <sub>CE</sub> (Sat)	I <sub>c</sub> = 150mA, I <sub>B</sub> = 15mA	-	0.3	V
		I <sub>c</sub> = 500mA, I <sub>B</sub> = 50mA	-	1	
Base Emitter Saturation Voltage	*V <sub>BE</sub> (Sat)	I <sub>c</sub> = 150mA, I <sub>B</sub> = 15mA	-	0.6 to 1.2	
		I <sub>c</sub> = 500mA, I <sub>B</sub> = 50mA	-	2	

## Electrical Characteristics (T<sub>A</sub> = 25°C unless otherwise specified)

Parameter	Symbol	Test Condition	Rating	Unit
DC Current Gain	h <sub>FE</sub>	I <sub>C</sub> = 0.1mA, V <sub>CE</sub> = 10V	>35	-
		I <sub>C</sub> = 1mA, V <sub>CE</sub> = 10V	>50	
		I <sub>C</sub> = 10 mA, V <sub>CE</sub> = 10V	>75	
		T <sub>A</sub> = 55°C		
		I <sub>C</sub> = 10mA, V <sub>CE</sub> = 10V	>35	
		I <sub>C</sub> = 150mA, V <sub>CE</sub> = 10V	100 to 300	
		I <sub>C</sub> = 150mA, V <sub>CE</sub> = 1V	>50	
		I <sub>C</sub> = 500mA, V <sub>CE</sub> = 10V	>40	

### Dynamic Characteristics

		ALL F = 1kHz		
Small Signal Current Gain	h <sub>FE</sub>	I <sub>C</sub> = 1mA, V <sub>CE</sub> = 10V I <sub>C</sub> = 10mA, V <sub>CE</sub> = 10V	50 to 300 75 to 375	-
Input Impedance	h <sub>IE</sub>	I <sub>C</sub> = 1mA, V <sub>CE</sub> = 10V I <sub>C</sub> = 10mA, V <sub>CE</sub> = 10V	2 to 8 0.25 to 1.25	kΩ
Voltage Feedback Ratio	h <sub>RE</sub>	I <sub>C</sub> = 1mA, V <sub>CE</sub> = 10V I <sub>C</sub> = 10mA, V <sub>CE</sub> = 10V	<8 <4	x10 <sup>-4</sup>
Output Admittance	h <sub>OE</sub>	I <sub>C</sub> = 1mA, V <sub>CE</sub> = 10V I <sub>C</sub> = 10mA, V <sub>CE</sub> = 10V	5 to 35 25 to 200	umhos
Collector Base Time Constant	r <sub>b</sub> 'C <sub>c</sub>	I <sub>E</sub> = 20mA, V <sub>CB</sub> = 20V f = 31.8MHz	<150	ps

### Dynamic Characteristics

Real Part Common - Emitter High Frequency	Re (hie)	I <sub>C</sub> = 20mA, V <sub>CE</sub> = 20V	<60	Ω
Input Impedance	-	f = 300MHz	-	-
Noise Figure	N <sub>F</sub>	I <sub>C</sub> = 100μA, V <sub>CE</sub> = 10V R <sub>s</sub> = 1kΩ, f = 1kHz	<4	dB
Transistors Frequency	f <sub>t</sub>	I <sub>C</sub> = 20mA, V <sub>CE</sub> = 20V f = 100MHz	>300	MHz
Output Capacitance	C <sub>ob</sub>	V <sub>CB</sub> = 10V, I <sub>E</sub> = 0 f = 100kHz	<8	pF
Input Capacitance	C <sub>ib</sub>	V <sub>EB</sub> = 0.5V, I <sub>C</sub> = 0 f = 100kHz	<25	

### Switching Time

Delay Time	t <sub>d</sub>	I <sub>C</sub> = 150mA, I <sub>B1</sub> = 15mA	<10	ns
Rise Time	t <sub>r</sub>	V <sub>CC</sub> = 30V, V <sub>BE</sub> = 0.5V	<25	
Storage Time	t <sub>s</sub>	I <sub>C</sub> = 150mA, I <sub>B1</sub> =	<225	
Fall Time	t <sub>f</sub>	I <sub>B2</sub> = 15mA, V <sub>CC</sub> = 30V	<60	

\*Pulse Condition: Pulse Width = 300μs, Duty Cycle = 2%

## TO-18 Metal Can Package

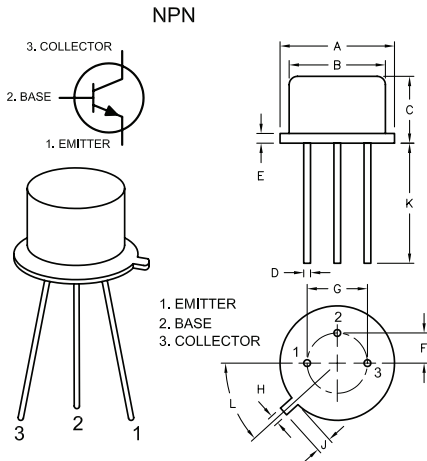

Dimensions	Minimum	Maximum
A	5.24	5.84
B	4.52	4.97
C	4.31	5.33
D	0.4	0.53
E	-	0.76
F	-	1.27
G	-	2.97
H	0.91	1.17
J	0.71	1.21
K	12.7	-
L	45°	

Dimensions : Millimetres

Material content declaration of TO-18 1pc weight: 0.3092gm				
Components	Substance make up of Material	Chemical Composition	CAS Number	Amount of substances (gm)
Header/cap	KOVAR, CRS1010	Fe Ni 29 Co 18 Glass	7439-89-6 7440-02-0 7440-48-4	0.2889gm
Chip	Silicon	Si	7440-21-3	0.0031gm
Bonding Wire	Aluminium (Al)	Al	7429-90-05	0.00089gm
Tin Plating	Pure Tin	Sn	7440-31-5	0.0074gm

## Part Number Table

Description	Part Number
Bipolar (BJT) Single Transistor, NPN, 40V, 300MHz, 1.2W, 800mA	2N2222A

**Important Notice :** This data sheet and its contents (the "Information") belong to the members of the AVNET group of companies (the "Group") or are licensed to it. No licence is granted for the use of it other than for information purposes in connection with the products to which it relates. No licence of any intellectual property rights is granted. The Information is subject to change without notice and replaces all data sheets previously supplied. The Information supplied is believed to be accurate but the Group assumes no responsibility for its accuracy or completeness, any error in or omission from it or for any use made of it. Users of this data sheet should check for themselves the Information and the suitability of the products for their purpose and not make any assumptions based on information included or omitted. Liability for loss or damage resulting from any reliance on the Information or use of it (including liability resulting from negligence or where the Group was aware of the possibility of such loss or damage arising) is excluded. This will not operate to limit or restrict the Group's liability for death or personal injury resulting from its negligence. Multicomp Pro is the registered trademark of Premier Farnell Limited 2019.