

Model EM-T-7A Extension Module

One- or two-channel control for use with a Primary Safety Device

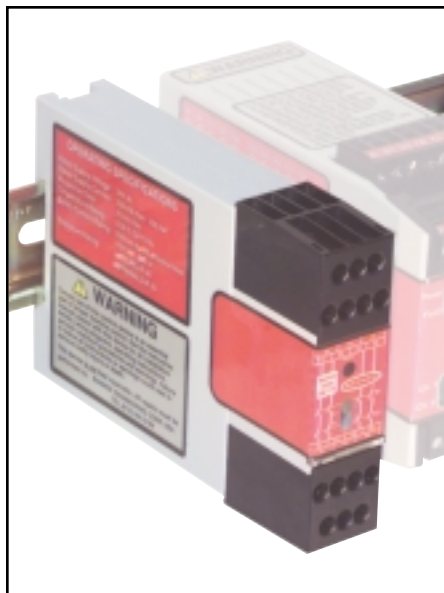

Features

- Extension Module provides additional safety outputs for a Primary Safety Device (for example, an E-stop Safety Module or a 2-hand control module), if controlled and monitored by this device
- Features four 6-amp switching channels for connection to control-reliable machine power interrupt circuits
- Four redundant output channels
- Contact status outputs are provided for connection to the Primary Safety Device's monitoring input
- 24V dc operation
- Housed in a narrow, 22.5 mm (0.9") DIN-rail-mountable module
- Convenient plug-in terminal blocks
- Design complies with standards UL 991 and EN 60204

Description

The model EM-T-7A Extension Module provides additional forced-guided (positive-guided) relay contacts for a Primary Safety Device, such as an E-stop Safety Module or a two-hand-control module. Controlled by the safety outputs of the Primary Safety Device, the EM-T-7A Extension Module provides four redundant outputs. These outputs may be connected to control-reliable machine power interrupt circuits. Each of the four Extension Module outputs is a series connection of two forced-guided relay contacts (K1 and K2 in Figure 3).

The outputs of the Extension Module follow the action of the safety outputs from the Primary Safety Device which control it, within a switching delay time of approximately 20 milliseconds. The Extension Module's four outputs are each rated for up to 250V ac/dc at up to 6A.

The Extension Module offers an output circuit at terminals Y1 and Y2 which provides K1 and K2 contact status information for connection to the monitoring input of the Primary Safety Device (see Figure 3). This monitoring circuit prevents the Primary Safety Device from being reset if contacts of either K1 or K2 of the Extension Module fail in a shorted condition.

The Extension Module has indicators for input power (green), and status of internal relays (K1 and K2, both green) (see Figure 1). There are no adjustments and no user-serviceable parts. See page 6 for information regarding repair service.



WARNING . . . This Extension Module is not a point-of-operation guarding device, as defined by OSHA regulations. It is necessary to install point-of-operation guarding devices, such as safety light curtains and/or hard guards, to protect personnel from hazardous machinery. **Failure to install point-of-operation guards on hazardous machinery could lead to serious injury or death.**



IMPORTANT NOTICE . . . Read this page before proceeding!

Banner Engineering Corp. has made every effort to provide complete application, installation, operation, and maintenance instructions. In addition, any questions regarding the use or installation of this Banner Extension Module should be directed to the factory applications department at the telephone numbers or addresses shown on the back cover.

The user shall ensure that all machine operators, maintenance personnel, electricians, and supervisors are thoroughly familiar with and understand all instructions regarding the installation, maintenance, and use of this Extension Module, and with the machinery it controls.

The user and any personnel involved with the installation and use of this Extension Module must be thoroughly familiar with all applicable ANSI/NFPA standards. The standards, listed below, directly address the use of Primary Safety Devices, by which the Extension Module can be controlled. Banner Engineering Corp. makes no claim regarding a specific recommendation of any organization, the accuracy or effectiveness of any information provided, or the appropriateness of the provided information for a specific application.

The user has the responsibility to ensure that all local, state, and national laws, rules, codes, and regulations relating to the use of this Extension Module in any particular application are satisfied. Extreme care is urged that all legal requirements have been met and that all installation and maintenance instructions contained in this manual are followed.

U. S. Standards Applicable to Use of Primary Safety Devices

ANSI B11	Standards for Machine Tools “Safety Requirements for the Construction, Care and Use” Available from: Safety Director AMT – The Association for Manufacturing Technology 7901 Westpark Drive McLean, VA 22101-4269 Tel.: 703-827-5266
NFPA 79	“Electrical Standard for Industrial Machinery (1997)” Available from: National Fire Protection Association 1 Batterymarch Park, P.O. Box 9101 Quincy, MA 02269-9101 Tel.: 800-344-3555
ANSI/RIA R15.06	“Safety Requirements for Industrial Robots and Robot Systems” Available from: Robotic Industries Association 900 Victors Way, P.O. Box 3724 Ann Arbor, MI 48106 Tel.: 734-994-6088

European Standards Applicable to Use of Primary Safety Devices

EN 292-1	“Safety of Machinery – Basic Concepts, General Principles for Design Part 1: Basic Terminology, Methodology”
EN 292-2	“Safety of Machinery – Basic Concepts, General Principles for Design Part 2: Technical Principles and Specifications”
EN 60204-1	“Electrical Equipment of Machines: Part 1: General Requirements” Also, request a type “C” standard for your specific machinery.
EN 418	“Safety of Machinery – Emergency Stop Equipment Functional Aspects, Principles for Design” Available from: Global Engineering Documents 15 Inverness Way East Englewood, CO 80112-5704 Tel.: 800-854-7179

Extension Module – Model EM-T-7A

Model EM-T-7A Specifications

Supply Voltage and Current	A1-A2: 24V dc, +/-15%, 10% maximum ripple
Supply Protection Circuitry	Protected against transient voltages and reverse polarity
Output Configuration	<p>Four output channels: Each channel is a series connection of two forced-guided (positive-guided) relay contacts – AgNi, gold-flashed</p> <p>Contact ratings: Maximum voltage: 250V ac/dc Maximum current: 6 A ac/dc Minimum current: 30 mA @ 24V dc Maximum power: 1500VA, 200 W Mechanical life: 50,000,000 operations Electrical life: 100,000 at full resistive load Feedback contact rating (Y1-Y2): 24V dc @ 0.5A</p> <p>NOTE: Transient suppression is recommended when switching inductive loads. Install suppressors across load. Never install suppressors across output contacts (see Warning, page 5).</p>
Output Response Time	20 milliseconds maximum (if channel u-k fails, maximum response time is 200 milliseconds)
Input Requirements	Inputs from Primary Safety Device must each be capable of switching 30 to 250mA @ 13 to 28V dc.
Status Indicators	<p>3 green LED indicators: Power ON K1 energized K2 energized</p>
Construction	Polycarbonate housing.
Environmental Rating	Rated NEMA 1, IEC IP20. Extension Module must be installed inside an enclosure rated NEMA 3 (IEC IP54), or better.
Mounting	Mounts to standard 35 mm DIN-rail track.
Vibration Resistance	10 to 55Hz @ 0.35 mm displacement per IEC 68-2-6
Operating Temperature	0° to +50°C (+32° to 122°F)
Application Notes	There are no adjustments and no user-serviceable parts. See page 6 for information regarding repair service.
Certifications	

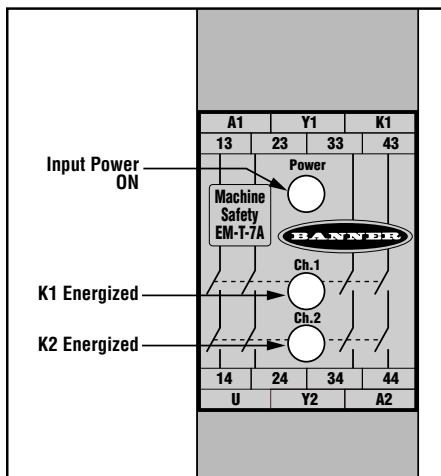

Figure 1. EM-T-7A status indicators

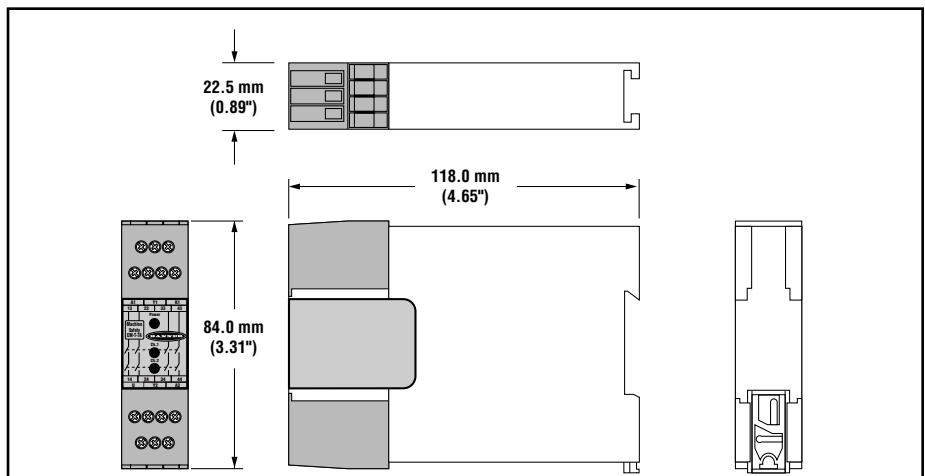

Figure 2. Extension Module enclosure dimensions

Extension Module – Model EM-T-7A

Installation

Primary Safety Device Requirements

Model EM-T-7A Extension Module is driven by one or two safety output channels of a Primary Safety Device. The design of the Primary Safety Device must meet OSHA and ANSI control reliability requirements. The EM-T-7A must be used **ONLY** with Primary Safety Devices which have a dedicated input for feedback monitor contacts (see hookup diagrams).

Each output channel of the Primary Safety Device must meet the following requirements:

- Include two (or more) redundant, normally open forced-guided (positive-guided) contacts,
- Be self-monitored to result in a safe (open) condition in the event of a contact failure, and
- Be capable of switching 30 to 250 mA at 13 to 28V dc.

Mechanical Installation

The model EM-T-7A Extension Module must be installed inside an enclosure. It is not designed for exposed wiring. It is the user's responsibility to house the Extension Module in an enclosure with NEMA 3 (IEC IP54) rating, or better.

Dimensions of the Extension Module are shown in Figure 2; it mounts directly to standard 35mm DIN rail.

Electrical Installation

As the Extension Module can be used with many different Primary Safety Devices and can interface to a multitude of machine control configurations, it is not possible to give exact wiring instructions for the output contacts. The following guidelines are general in nature.

The output contacts of the Extension Module have no delay function. They will open within 20 milliseconds from the time that the controlling contacts coming from the Primary Safety Device open.

IMPORTANT: Review the following discussion of one-channel and two-channel control before connecting the Extension Module to its Primary Safety Device.



WARNING . . . Not for Use As a Stand-Alone Safety Relay

1) DO NOT connect E-stop switches, 2-hand-control switches, safety interlock switches, or similar devices directly to this Extension Module.

2) ALWAYS connect terminals Y1 and Y2 of this Extension Module to the monitoring input of the Primary Safety Device that controls it (see Figure 3).

This Extension Module does not have the circuitry required to perform a self-check. A single fault inside the unit or in external devices like switches or E-Stop buttons connected to the unit can go undetected and create an unsafe condition. **Failure to properly connect this Extension Module to a control-reliable Primary Safety Device could result in serious injury or death.**



CAUTION . . . Dangerous Voltages

Always disconnect all power from the Extension Module, the Primary Safety Device, and from the machine being controlled before making any wire connections. Electrical installation and wiring must be made by qualified personnel and must comply with the NEC (National Electrical Code), EN 60204-1 and -2, and all applicable local standards and codes.



WARNING . . .
Use of Arc Suppressors

If arc suppressors are used, they **MUST** be installed as shown across the actuator coil of the master stop control elements (MSC1 to MSC4). **NEVER** install suppressors directly across the output contacts of the Extension Module. It is possible for suppressors to fail as a short circuit. If installed directly across the output contacts of the Extension Module, a short-circuited suppressor will create an unsafe condition which could result in serious injury or death.



WARNING . . .
Maintain Control Reliability

NEVER wire an intermediate device (e.g., a programmable logic controller/ PLC), other than a safety relay, between any safety output of the Extension Module and the master stop control element it switches. To do so sacrifices the control reliability of the control-to-machine interface, and creates an unsafe condition which could result in serious injury or death. Whenever a safety relay is added as an intermediate switching device, a normally-closed forced-guided monitor contact of that relay must be added to the series feedback loop.

(Reference ANSI B11.1 – 1988, Appendix B4)

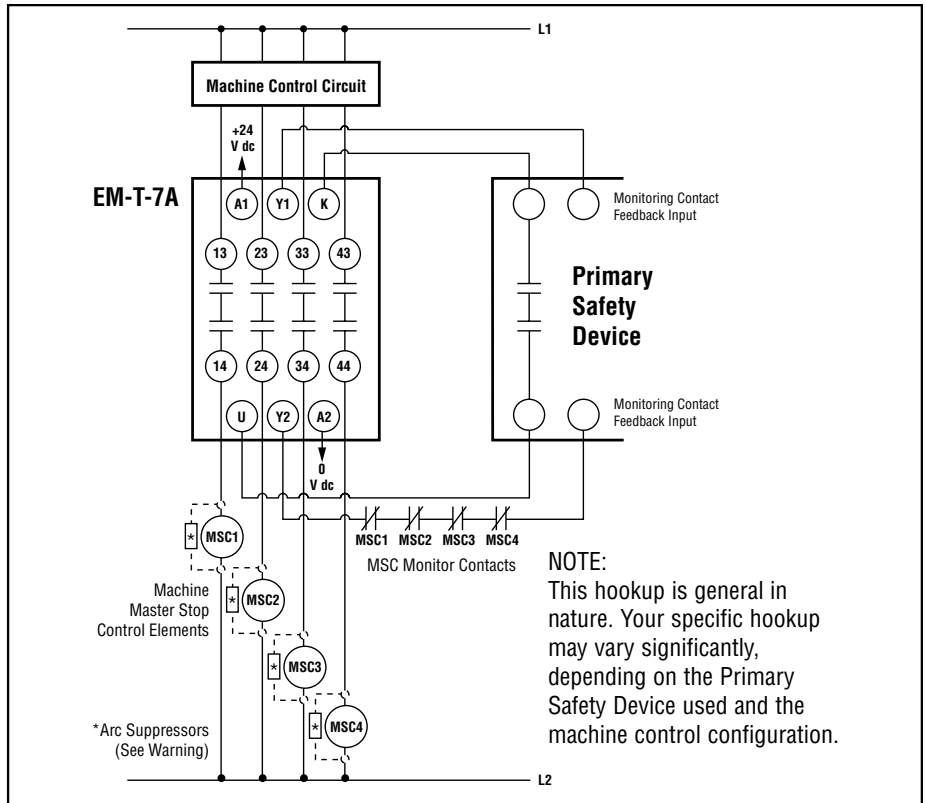

Figure 3. Generalized EM-T-7A Hookup for One-Channel Control

One-Channel Control (Figure 3)

One-channel control affords simplicity of wiring. However, one-channel wiring requires eliminating the possibility of an unsafe failure of the control wires (which connect the output of the Primary Safety Device to the input of the Extension Module). One of the ways to reduce the probability of such failure is to locate the Primary Safety Device adjacent to the Extension Module in the same enclosure.

The output of the Primary Safety Device must consist of two or more series-connected, normally open contacts, coming from forced-guided safety relays. These contacts must be monitored for failure by the Primary Safety Device. In addition, a single contact failure cannot prevent normal stopping action, and a successive cycle cannot be initiated until the failure has been corrected. An example of this type of output is any single output channel of a Banner E-stop safety module.

Extension Module – Model EM-T-7A

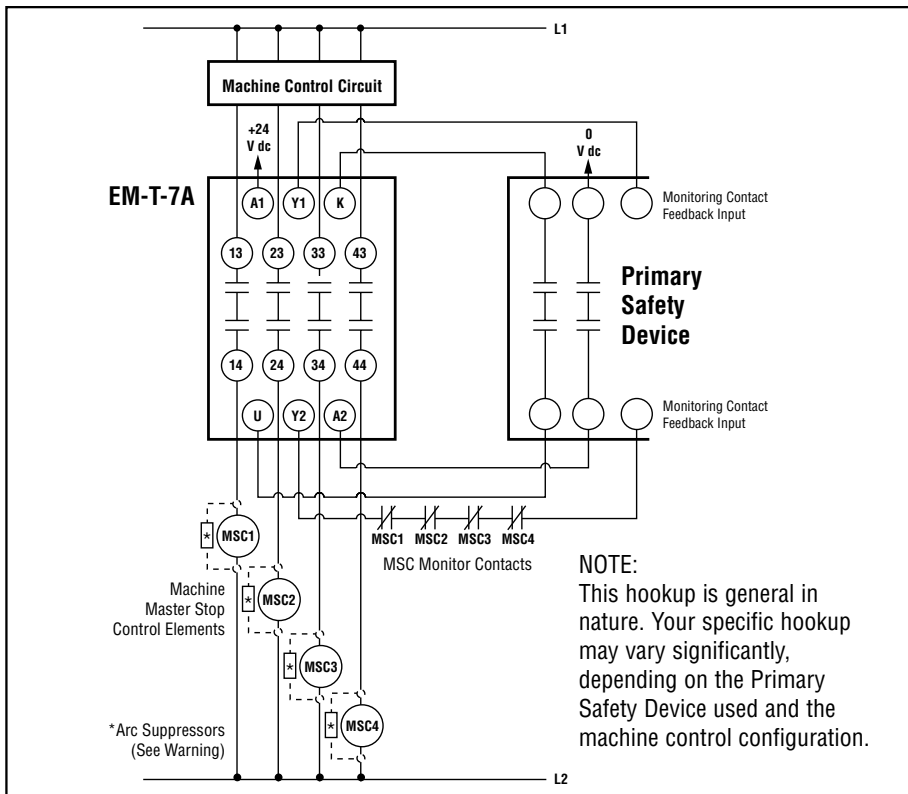

Figure 4. Generalized EM-T-7A Hookup for Two-Channel Control

Two-Channel Control (Figure 4)

Two-channel control allows the Primary Safety Device to detect an unsafe failure of the control wires. Two-channel control should be used whenever unsafe failure of the control wires cannot be eliminated.

The outputs of the Primary Safety Device must each be normally open, forced-guided contacts from redundant safety relays. These contacts must be monitored for failure by the Primary Safety Device. In addition, a single contact failure cannot prevent normal stopping action, and a successive cycle cannot be initiated until the failure has been corrected.

Connection to the Machine to be Controlled

The hookup diagrams in Figures 3 and 4 show a generic connection of the four safety output channels of the Extension Module to Master Stop Control Elements MSC1 through MSC4. A Master Stop Control Element is defined as an electrically powered device, external to the Extension Module, which stops the machinery being controlled by immediate removal of electrical power to the machine and (when necessary) by applying braking to dangerous motion (reference ANSI B11.19, section 5.2: “Stop Control”). **To achieve control reliability, two redundant MSCs are required to control each machine hazard.**

NOTICE regarding MSCs

To achieve control reliability, two redundant Master Stop Control Elements (MSCs) are required to control each machine hazard. Each MSC must be capable of immediately stopping the dangerous machine motion, irrespective of the state of the other. Some machines offer only one primary control element. For such machines, it is necessary to duplicate the circuit of the single MSC to add a second MSC.

MSCs must offer at least one forced-guided auxiliary contact which is wired to the monitoring contact feedback input of the Primary Safety Device (see hookup diagrams).

To satisfy the requirements of control reliability, all MSCs must offer at least one normally closed forced-guided monitor contact. One normally closed monitor contact from each MSC is wired in series to the monitoring contact feedback input of the Primary Safety Device, as shown in Figures 3 and 4. In operation, if one of the switching contacts of any MSC fails in the shorted condition, the associated monitor contact will remain open. As a result, it will not be possible to reset the Primary Safety Device.

Many types of mechanisms are used to arrest dangerous machine motion. Examples include mechanical braking systems, clutch mechanisms, and combinations of brakes and clutches. Additionally, control of the arresting scheme may be hydraulic or pneumatic. As a result, an MSC may be one of several control types, including a wide variety of contactors and electromechanical valves. If your machine documentation leaves any doubt about the proper connection points for the Extension Module output contacts, do not make any connections. Contact the machine builder for clarification regarding connection to the MSCs.

Initial Checkout Procedure



CAUTION . . . Disconnect Power Prior to Checkout

Before performing the initial checkout procedure, make certain all power is disconnected from the machine to be controlled. Dangerous voltages may be present along the Extension Module wiring barriers whenever power to the machine control elements is ON.

Exercise extreme caution whenever machine control power is or may be present.

NOTE: The Extension Module can only be used safely when its operation is controlled via an appropriate Primary Safety Device, connected to the Extension Module according to wiring diagrams shown in Figure 3 or 4.

Checkout procedure:

- 1) Remove the power controlling and switched by the machine control elements (see Caution at left).
- 2) Verify that the Primary Safety Device which will be controlling the Extension Module is operating correctly, according to its product documentation and manufacturer's recommendations.
- 3) Confirm proper connection of the Extension Module to the controlling Primary Safety Device according to the wiring diagram (see Figures 3 and 4).
- 4) Verify that all four Extension Module output contacts follow exactly the operation of the safety output contacts of the controlling Primary Safety Device, when the Primary Safety Device is operated according to its product documentation and manufacturer's recommendations.



WARNING . . . MSC Monitoring

All Master Stop Control elements (MSCs), such as control relays, must be of forced-guided, captive contact design to allow the MSC Monitoring circuit to detect unsafe failures within the master stop control elements. This monitoring extends the safe switching point of the Primary Safety Device and the EM-T-7A Extension Module to the MSC elements. For this monitoring to be effective, it is required that a minimum of two redundant MSCs control each hazard. This is to detect the unsafe failure of one MSC (e.g. a welded contact), while stopping the hazard and preventing a successive machine cycle with the second MSC.

If the MSCs are the last electrically controlled device generating the hazard (i.e. not relays or contactors) and do not have forced-guided, captive contacts to monitor, then the customer must ensure that failure or fault of any single component of the MSCs will not result in a hazardous situation and will prevent a successive machine cycle.

NOTE: MSC Monitoring is also called External Device Monitoring (EDM), MPCE Feedback, and relay backchecking.

Extension Module – Model EM-T-7A

Periodic Checkout

The checkout procedure described on page 7 should be performed according to the intervals specified by the product documentation of the Primary Safety Device controlling this Extension Module.

Repairs

Do not attempt any repairs to the EM-T-7A Extension Module. It contains no field-replaceable components. Return the Extension Module to the factory for warranty repair or replacement.

If it ever becomes necessary to return an Extension Module to the factory, please do the following:

- 1) Contact the Banner Factory Application Engineering Group at the addresses or at the numbers listed at the bottom of page 8. They will attempt to troubleshoot the system from your description of the problem. If they conclude that a component is defective, they will issue an RMA (Return Merchandise Authorization) number for your paperwork, and give you the proper shipping address.
- 2) Pack the Extension Module carefully. Damage which occurs in return shipping is not covered by warranty.



the machine safety specialist

WARRANTY: Banner Engineering Corp. warrants its products to be free from defects for one year. Banner Engineering Corp. will repair or replace, free of charge, any product of its manufacture found to be defective at the time it is returned to the factory during the warranty period. This warranty does not cover damage or liability for the improper application of Banner products. This warranty is in lieu of any other warranty either expressed or implied.