

RF Inductor



BWCS Series



Overview

Wire-wound RF inductors are electronic components designed to store energy in a magnetic field when electrical current passes through them. They are constructed by winding a conductive wire (usually copper or gold-plated) around a core material such as air, ceramic, or ferrite.

This configuration allows them to provide high inductance values with minimal power loss, especially at high frequencies.

Benefits

1. High Q-Factor (Quality Factor)
2. Ceramic body and wire wound construction provide high SRFs
3. Low DC resistance design
4. High Current Handling
5. Can maintain excellent thermal stability at different temperatures

Applications

1. Industrial and Medical Equipmen: RFID systems and medical imaging equipment.
2. Data Centers
3. Networking
4. Base Station
5. Consumer Electronics
6. Security system

Product Information

Series	Size Code (JIS/EIA)	Inductance (nH)
BWCS	0603/0201	1 ~ 470
	1005/0402	
	1608/0603	
	2012/0805	
	2520/1008	
	4938/1812	



BWCS00060404 Series Specification

1 Scope: This specification applies to Wire Wound Ceramic Chip Inductors

2 Part Numbering:

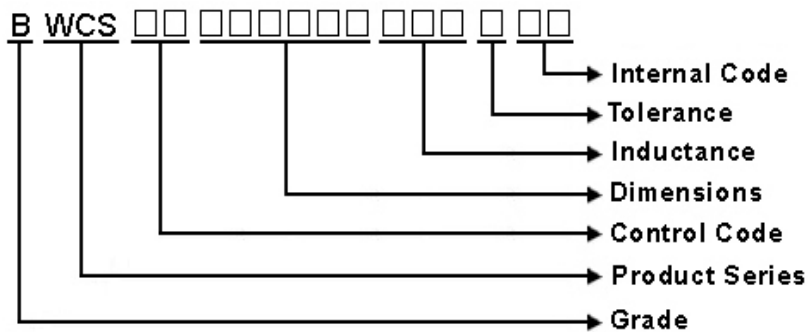

3 Rating:

Operating Temperature: - 4 0 °C ~ 1 2 5 °C
(Including self - temperature rise)

Storage Temperature: - 4 0 °C ~ 1 2 5 °C

(The storage temperature range is for after the assembly)

4 Marking:

No Marking

5 Standard Testing Condition

	Unless otherwise specified	In case of doubt
Temperature	Ordinary Temperature(15 to 35°C)	20 to 30°C
Humidity	Ordinary Humidity(25 to 85% RH)	50 to 80 %RH

BWCS00060404 Series Specification

6 Configuration and Dimensions and Unit Weight:

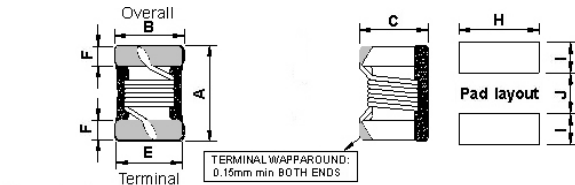

Dimensions in mm

TYPE	A	B	C	E	F	H	I	J
060404	0.58Max.	0.46Max.	0.45Max.	0.38	0.1	0.46	0.18	0.23

Net Weight (grms)

SIZE CODE	Net Weight (grms)
060404	0.00022 (typ.)

7 Electrical Characteristics:

Part No.	Inductance (nH)	L/Q Test Freq. (MHz)	Q Min.	SRF (GHz)Typ.	RDC (Ω)Max.	Irms (mA)Typ.	Tolerance
BWCS000604040N5□00	0.5	250/250	4	23.5	0.02	1250	K
BWCS000604040N6□00	0.6	250/250	6	24.5	0.03	1000	K
BWCS000604041N2□00	1.2	250/250	13	17.9	0.042	870	J
BWCS000604041N3□00	1.3	250/250	11	17.6	0.048	820	J
BWCS000604041N4□00	1.4	250/250	14	17	0.08	630	J
BWCS000604041N5□00	1.5	250/250	11	17	0.09	600	J
BWCS000604042N2□00	2.2	250/250	15	16.7	0.07	700	J
BWCS000604042N3□00	2.3	250/250	18	16.5	0.07	670	J
BWCS000604042N4□00	2.4	250/250	13	13	0.082	620	J
BWCS000604042N5□00	2.5	250/250	16	12.5	0.165	440	J
BWCS000604043N3□00	3.3	250/250	14	12.8	0.08	630	J
BWCS000604043N4□00	3.4	250/250	11	12.7	0.08	630	J
BWCS000604043N5□00	3.5	250/250	16	12.4	0.08	630	J
BWCS000604043N6□00	3.6	250/250	18	12.5	0.105	550	J
BWCS000604043N7□00	3.7	250/250	15	10.6	0.105	550	J
BWCS000604043N8□00	3.8	250/250	16	10.2	0.18	420	J
BWCS000604043N9□00	3.9	250/250	12	11.2	0.24	360	J
BWCS000604044N8□00	4.8	250/250	17	11	0.096	570	J
BWCS000604044N9□00	4.9	250/250	18	11.7	0.13	510	J
BWCS000604045N0□00	5	250/250	18	11.5	0.13	510	J
BWCS000604045N1□00	5.1	250/250	18	11.1	0.13	510	J
BWCS000604045N2□00	5.2	250/250	18	10	0.17	430	J
BWCS000604045N3□00	5.3	250/250	18	10.6	0.13	510	J
BWCS000604045N4□00	5.4	250/250	18	10.2	0.13	510	J
BWCS000604045N5□00	5.5	250/250	16	9.5	0.285	330	J

NOTE: □-tolerance J=±5% / K=±10%

1. Operating temperature range - 4 0 °C ~ 1 2 5 °C
2. Irms for a 15°C temperature rise from 25°C ambient.
3. L/Q Test OSC @200mV.

BWCS00060404 Series Specification

Part No.	Inductance (nH)	L/Q Test Freq. (MHz)	Q Min.	SRF (GHz)Typ.	RDC (Ω)Max.	Irms (mA)Typ.	Tolerance
BWCS000604046N7□00	6.7	250/250	18	6.8	0.15	460	J
BWCS000604046N8□00	6.8	250/250	18	9.5	0.15	460	J
BWCS000604046N9□00	6.9	250/250	18	9.3	0.15	460	J
BWCS000604047N0□00	7	250/250	18	6.7	0.21	390	J
BWCS000604047N1□00	7.1	250/250	18	9.5	0.25	390	J
BWCS000604047N2□00	7.2	250/250	18	9.4	0.25	390	J
BWCS000604047N3□00	7.3	250/250	18	9.3	0.25	390	J
BWCS000604047N4□00	7.4	250/250	18	9.1	0.25	390	J
BWCS000604047N5□00	7.5	250/250	15	6.8	0.34	300	J
BWCS000604047N6□00	7.6	250/250	17	9.3	0.3	340	J
BWCS000604047N7□00	7.7	250/250	17	9.2	0.3	340	J
BWCS000604047N8□00	7.8	250/250	17	9.2	0.3	340	J
BWCS000604047N9□00	7.9	250/250	17	9.1	0.3	340	J
BWCS000604048N0□00	8	250/250	17	9.2	0.3	340	J
BWCS000604048N1□00	8.1	250/250	17	9.1	0.3	340	J
BWCS000604048N2□00	8.2	250/250	17	6.4	0.27	340	J
BWCS000604048N3□00	8.3	250/250	17	8.9	0.3	340	J
BWCS000604048N4□00	8.4	250/250	15	8.9	0.38	300	J
BWCS000604048N5□00	8.5	250/250	15	8.9	0.38	300	J
BWCS000604048N7□00	8.7	250/250	15	6.3	0.38	300	J
BWCS000604049N0□00	9	250/250	15	6.4	0.38	300	J
BWCS000604049N4□00	9.4	250/250	16	6.4	0.4	280	J
BWCS000604049N6□00	9.6	250/250	16	6.2	0.4	280	J
BWCS0006040411N□00	11	250/250	16	5.7	0.44	280	J
BWCS0006040412N□00	12	250/250	17	5.6	0.36	300	J
BWCS0006040413N□00	13	250/250	16	6.7	0.5	270	H,J
BWCS0006040414N□00	14	250/250	16	5.1	0.5	270	J

NOTE: □-tolerance J=±5% / K=±10%

1. Operating temperature range - 4 0 °C ~ 1 2 5 °C
2. Irms for a 15°C temperature rise from 25°C ambient.
3. L/Q Test OSC @200mV.

BWCS00060404 Series Specification

8 BWCS00060404 Series

8.1 Construction:

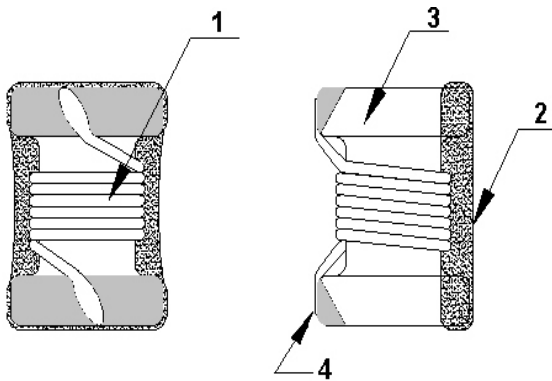

8.2 Material List:

NO	PART	MATERIAL
1	WIRE	Grade 180
2	EPOXY	UV GLUE
3	CORE	CERAMIC
4	TERMINAL	Ag/Ni/Sn

BWCS00060404 Series Specification

9 Reliability Of Ceramic Wire Wound Chip Inductor/CERAMIC SERIES

1-1.Environmental Performance

No	Item	Specification	Test Method		
1-1-1	Temperature Cycle	Appearance: No Damage Inductance: within $\pm 10\%$ of initial value Q change: within $\pm 30\%$ of initial value	One cycle:		
			Step	Temperature ($^{\circ}\text{C}$)	Time (min)
			1	-40 ± 3	30
			2	25 ± 2	15
			3	125 ± 3	30
			4	25 ± 2	15
			Total: 5 cycles Measured After Exposure in The Room Condition For 1hrs		
1-1-2	High Temperature Resistance		Temperature: $125\pm 3^{\circ}\text{C}$ Time: 1000Hrs Measured After Exposure In The Room Condition For 1Hrs		
1-1-3	Low Temperature Resistance		Temperature: $-40\pm 3^{\circ}\text{C}$ Time: 1000Hrs Measured After Exposure In The Room Condition For 1Hrs		
1-1-4	Humidity Load Life	There should be no evidence of short or open circle	Temperature: $40\pm 2^{\circ}\text{C}$ Relative Humidity: 90~95% Load: Allowed DC Current Time: 96Hrs		

1-2.Mechanical Performance

No	Item	Specification	Test Method
1-2-1	Vibration Test (Low Frequency)	1.Appearance: No Damage 2.Inductance: within $\pm 10\%$ of initial value 3.Q change: within $\pm 30\%$ of initial value	1. Test device shall be soldered on the substrate. 2. Oscillation frequency: 10 to 55 to 10Hz for 1min. 3. Amplitude: 1.5mm 4. Time: 2hrs for each axis(X, Y & Z), total 6hrs
1-2-2	Resistance TO Soldering Heat	Appearance: No Damage	1. The device should be reflow soldered on PCB (peak $260^{\circ}\text{C} \pm 5^{\circ}\text{C}$ for 10 seconds) 2. Solder Composition: Sn/Ag3.0/Cu0.5 3. Test time: 6 minutes
1-2-3	Solder ability	The electrodes shall be at least 95% covered with new solder coating	1. Pre-Heating: 150°C , 1min. 2. Solder Composition: Sn/Ag3.0/Cu0.5 3. Solder Temperature: $245\pm 5^{\circ}\text{C}$. 4. Immersion Time: 4 ± 1 sec.
1-2-4	Component Adhesion (Push Test)	0.5 Lbs. For 0201 1 Lbs. For 0402 2 Lbs. For 0603 4 Lbs. For The Rest	The device should be reflow soldered ($245\pm 5^{\circ}\text{C}$ For 10 seconds) to a tinned copper substrate. A force gauge should be applied to the side of the component. The device must withstand a minimum force of 2 or 4 pounds without a failure of the termination attached to component

BWCS00060404 Series Specification

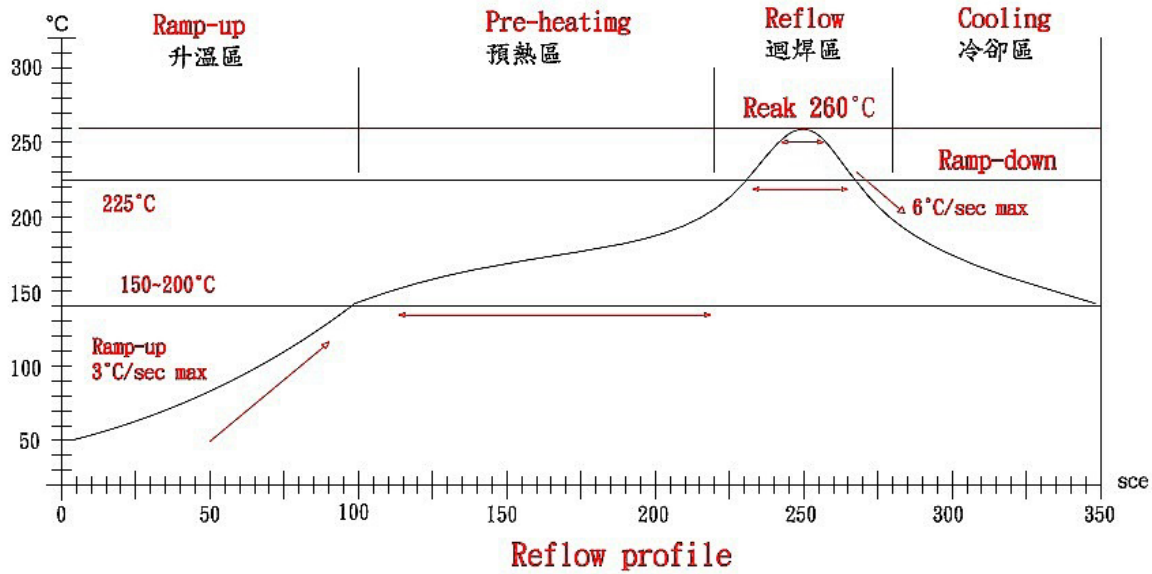

Lead-Free(LF)標準溫度分析範圍

Refer to J-STD-020C

管制項目 Item.	升温區 Ramp-up	預熱區 Pre-heating	迴焊區 Reflow	Peak Temp	冷卻區 Cooling
溫度範圍 Temp.scope	R.T ~ 150°C	150°C ~ 200°C	Above 217°C	260±5°C	Peak Temp.~150°C
標準時間 Time spec.	-	60 ~ 180 sec	60 ~ 150 sec	20 ~ 40 sec	-
實際時間 Time result	-	75 ~ 100 sec	90 ~ 120 sec	20 ~ 35 sec	-

NOTE:

- 1.Re-flow possible times : within 3 times
- 2.Nitrogen adopted is recommends while in re-flow
- 3.Products can only be soldered with reflow

BWCS00060404 Series Specification

10 Packaging:

10.1 Packaging -Cover Tape

The force for tearing off cover tape is 10 to 100 grams in the arrow direction.

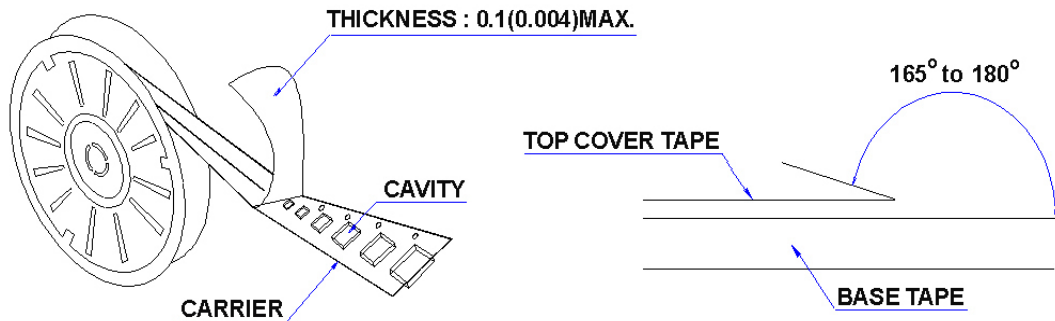

10.2 Packaging Quantity

TYPE	PCS/REEL
60404	4000

10.3 Reel Dimensions

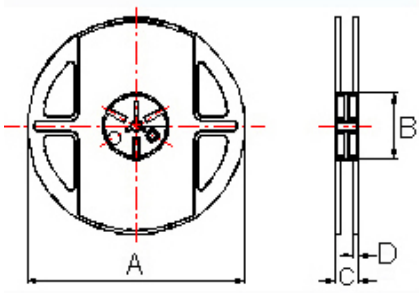

Dimensions in mm

TYPE	A	B	C	D
60404	178±1	60±0.5	12±0.5	1.5±0.5

BWCS00060404 Series Specification

10 Packaging:

10.4 Tape Dimensions in mm

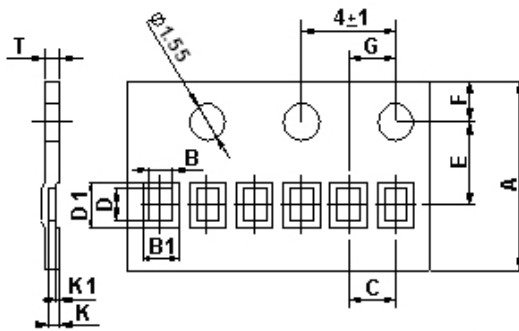

Tape Material

Carrier tape : Paper
Cover tape : Polyethylene

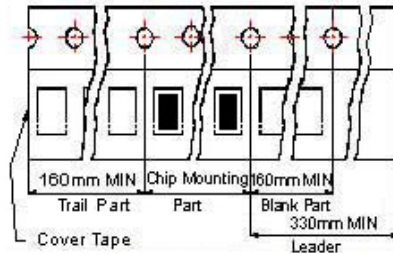

TYPE	A	B	B1	C	D	D1	E	F	G	T	K	K1
60404	8.0	0.47	0.8	2.0	0.60	0.89	3.5	1.75	2.0	0.65	0.45	0.13

11 Recommended Land Pattern:

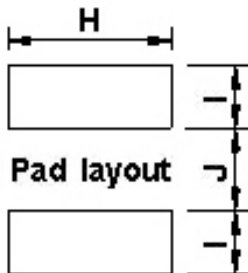

Dimensions in mm

TYPE	H(In/mm)	I(In/mm)	J(In/mm)
60404	0.46	0.18	0.23

12 Note:

- Please make sure that your product has been evaluated and confirmed against your specifications when our product is mounted to your product.
- Do not knock nor drop.
- All the items and parameters in this product specification have been prescribed on the premise that our product is used for the purpose, under the condition and in the environment agreed upon between you and us. You are requested not to use our product deviating from such agreement.
- The storage period is less than 12 months. Be sure to follow the storage conditions (Temperature: 5 to 40°C, Humidity: 10 to 75% RH or less).
If the storage period elapses, the soldering of the terminal electrodes may deteriorate.
- Do not use or store in locations where there are conditions such as gas corrosion (salt, acid, alkali, etc.)
- The moisture sensitivity level (MSL) of products is classified as level 1.

BWCS00060404 Series Specification

13 Graph:

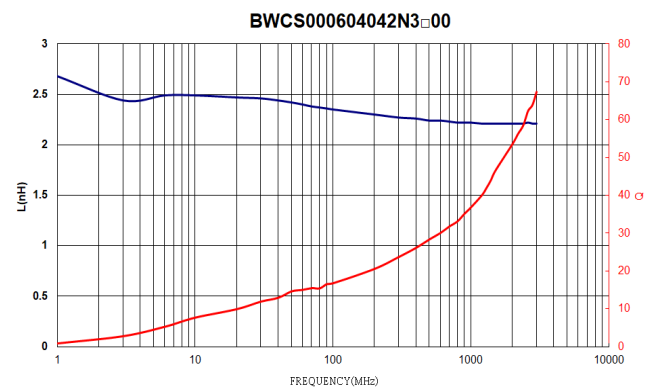
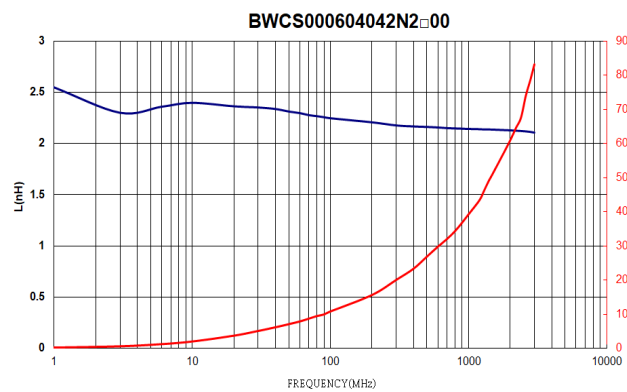
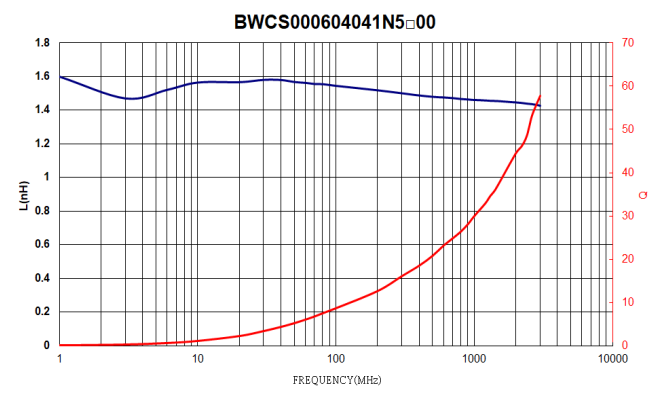
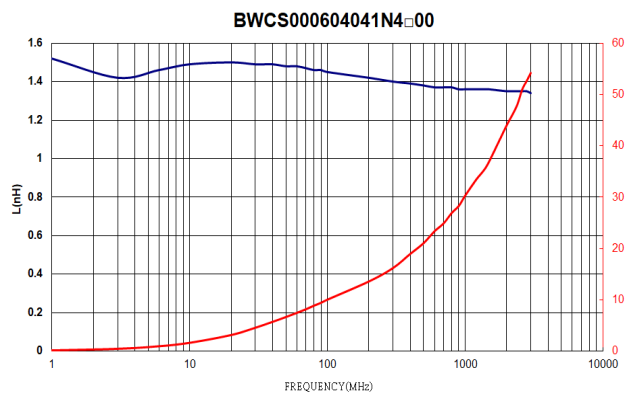
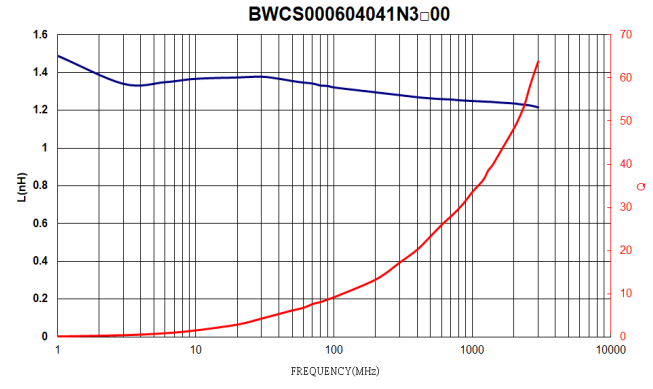
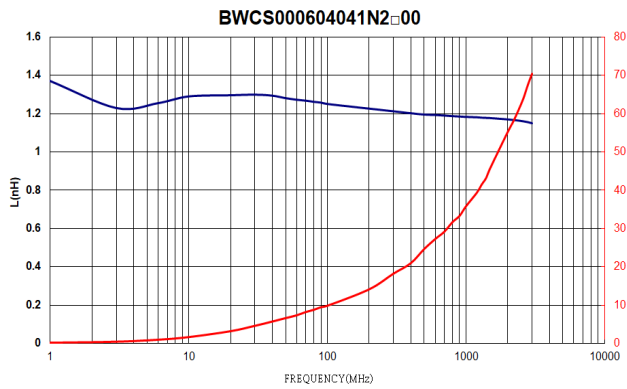
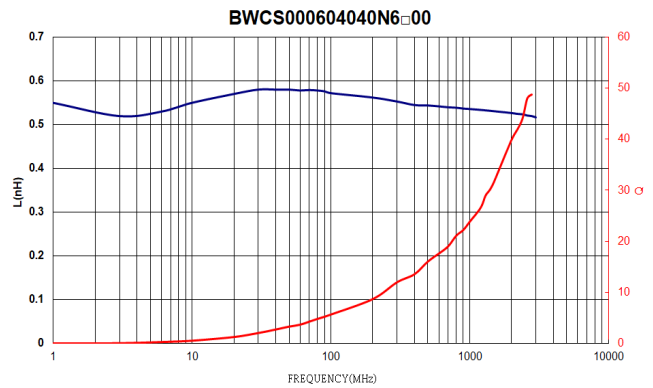
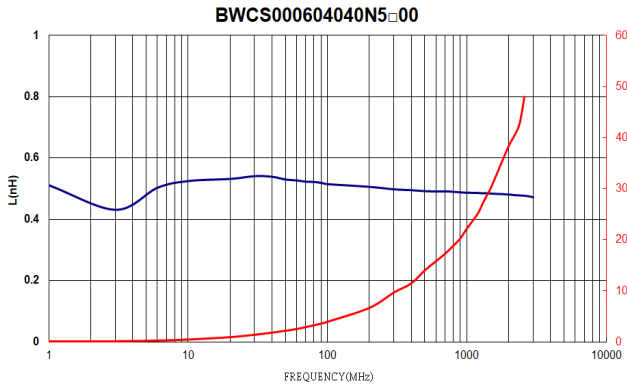

BWCS00060404 Series Specification

BWCS000604042N4□00

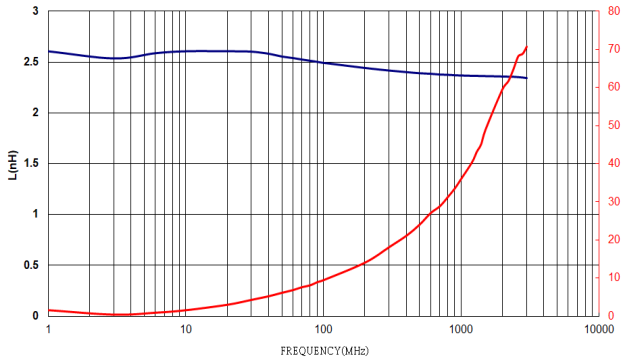

BWCS000604042N5□00

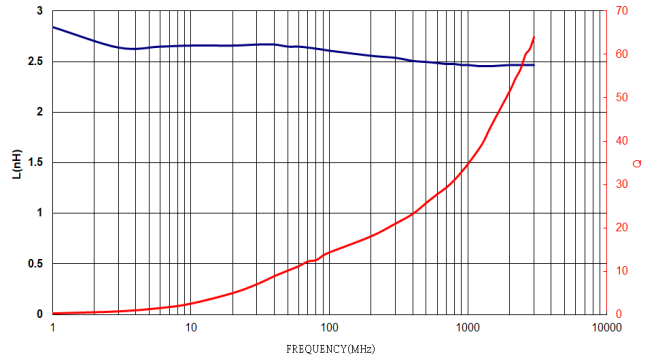

BWCS000604043N3□00

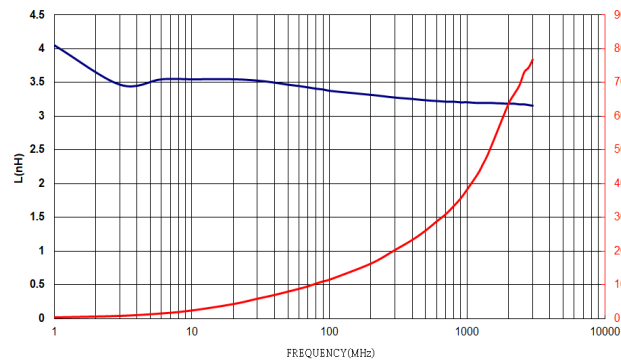

BWCS000604043N4□00

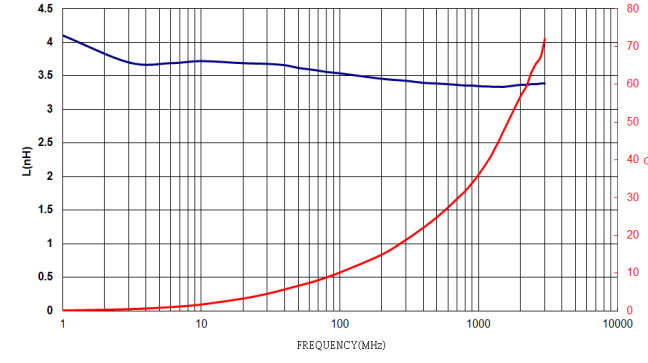

BWCS000604043N5□00

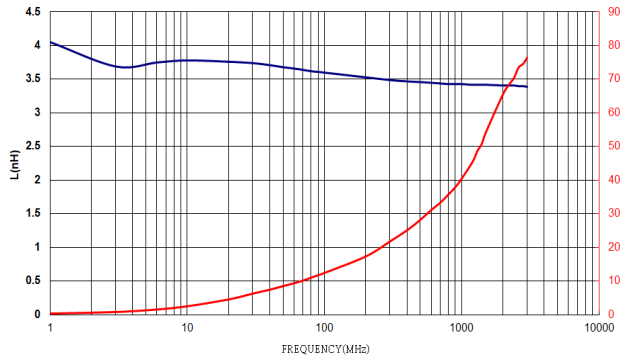

BWCS000604043N6□00

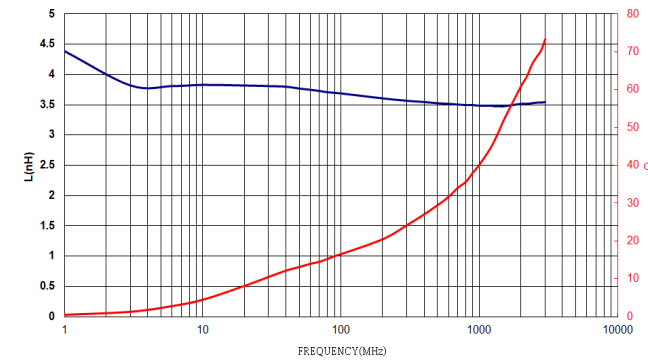

BWCS000604043N7□00

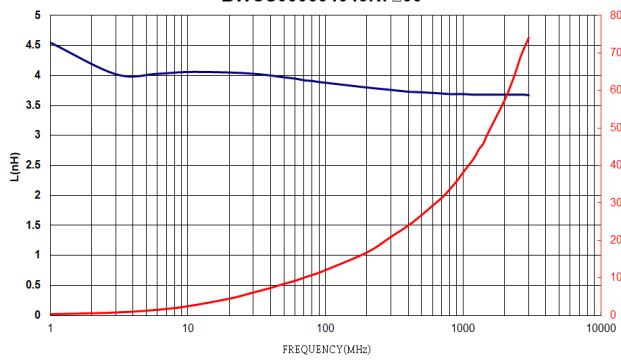

BWCS000604043N8□00

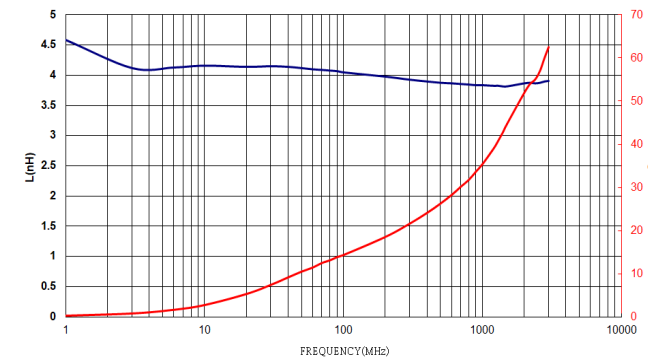

BWCS00060404 Series Specification

BWCS000604043N9-00

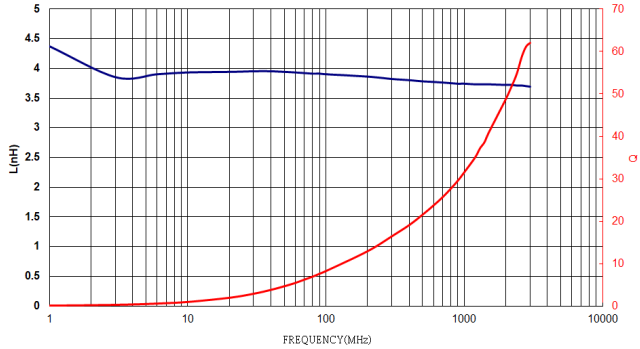

BWCS000604044N8-00

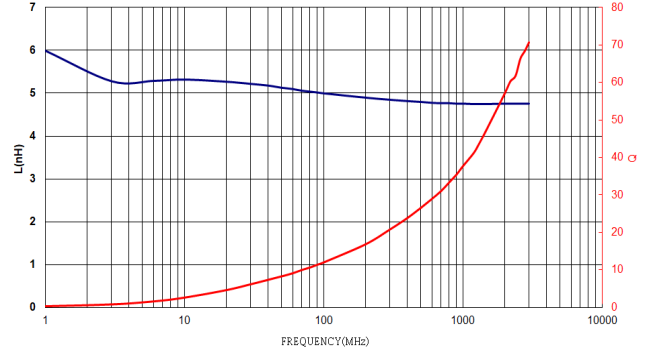

BWCS000604044N9-00

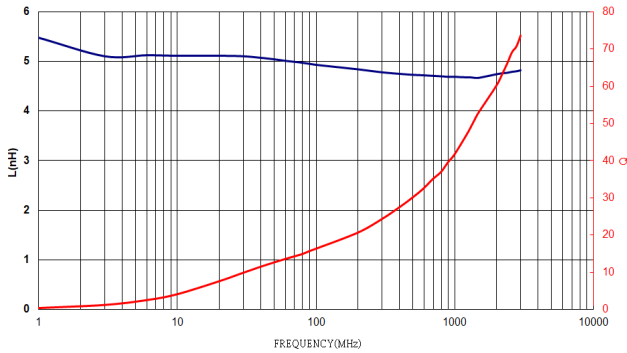

BWCS000604045N0-00

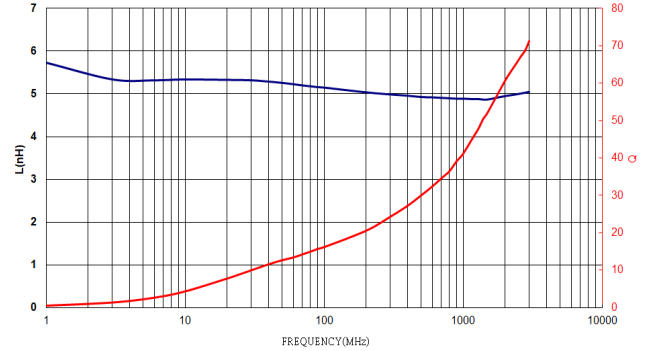

BWCS000604045N1-00

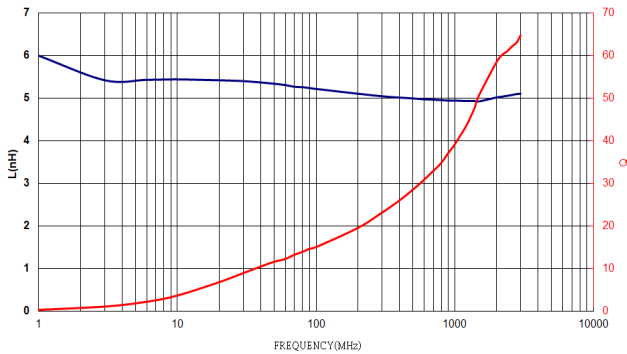

BWCS000604045N2-00

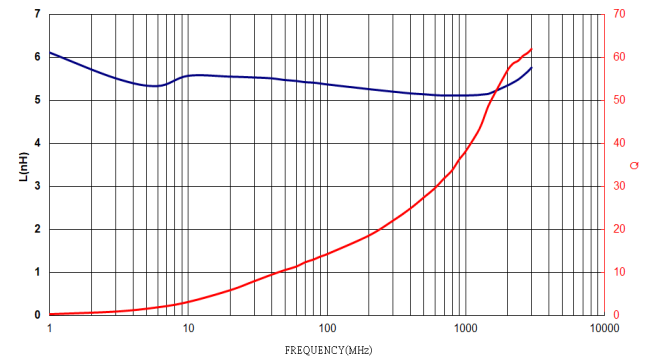

BWCS000604045N3-00

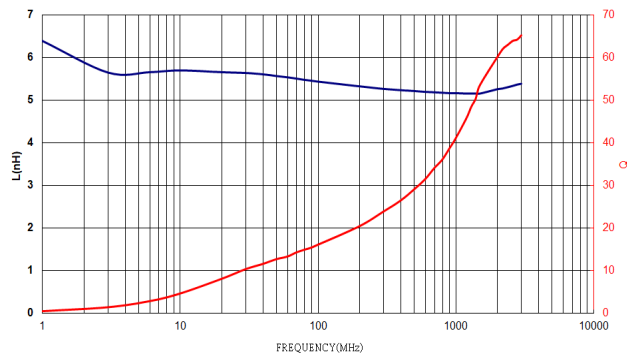

BWCS000604045N4-00

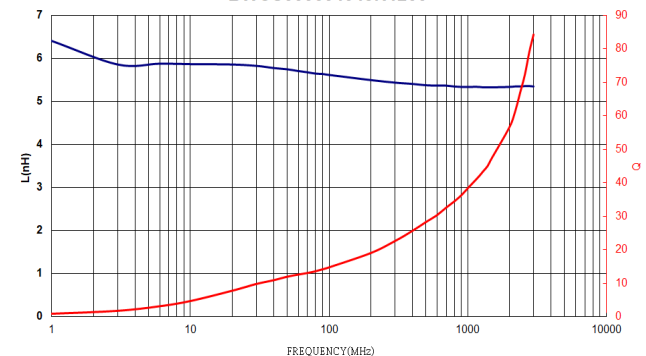

BWCS00060404 Series Specification

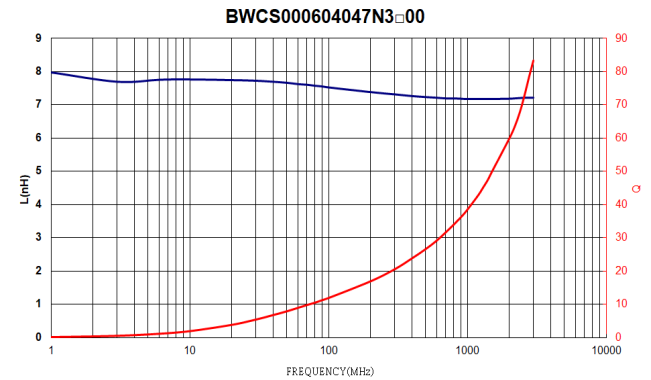
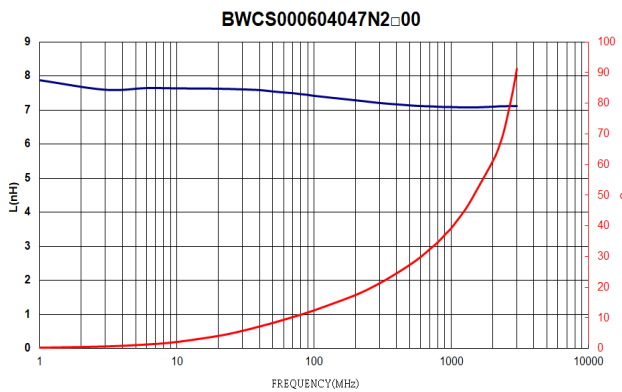
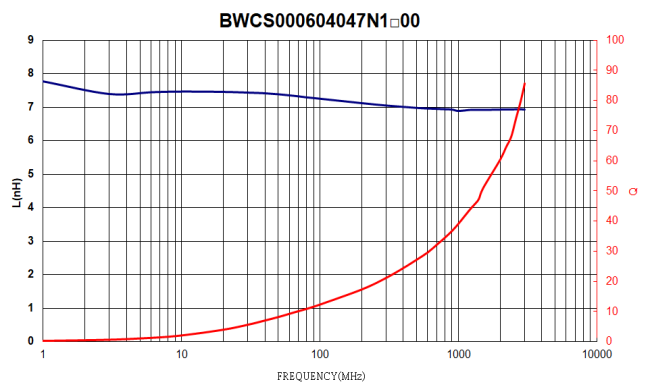
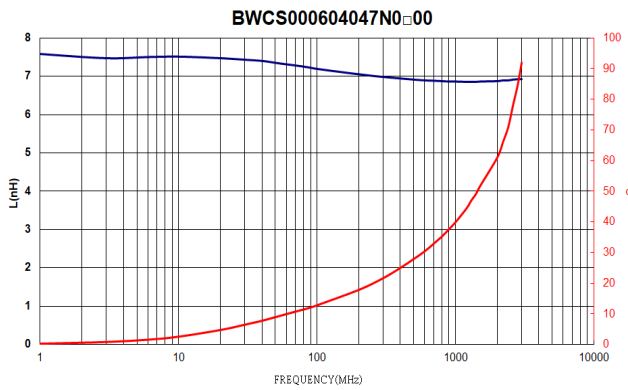
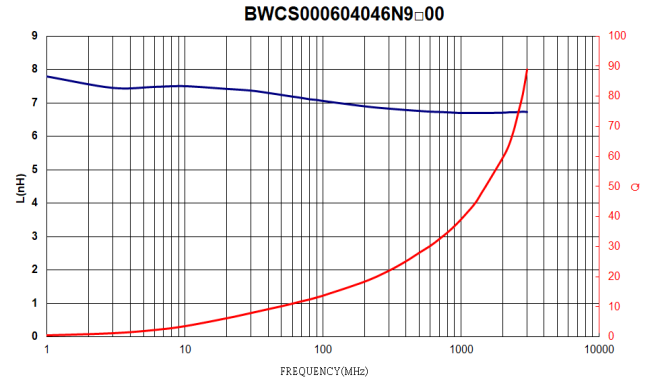
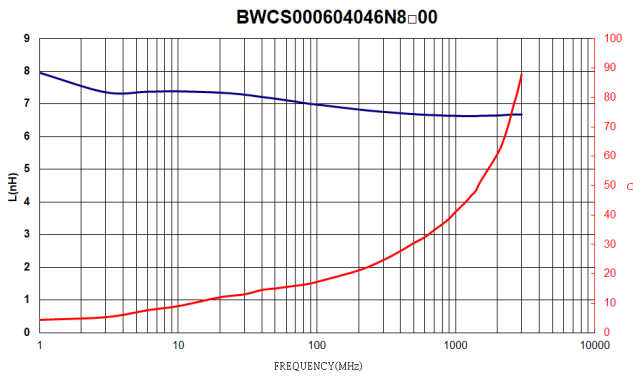
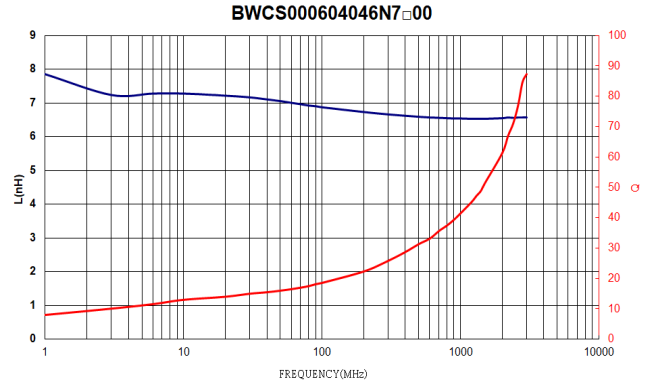
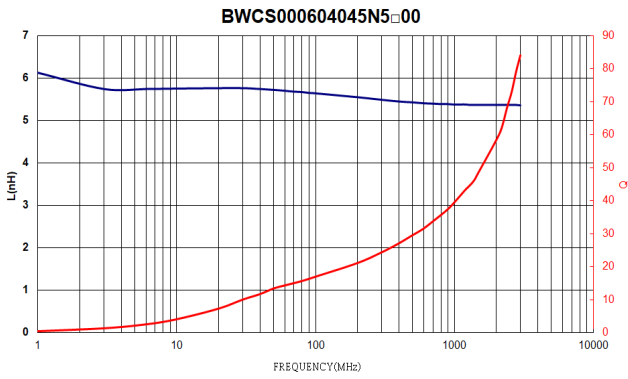

BWCS00060404 Series Specification

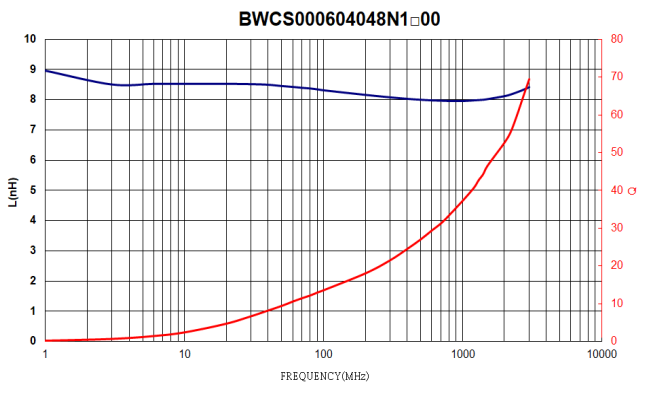
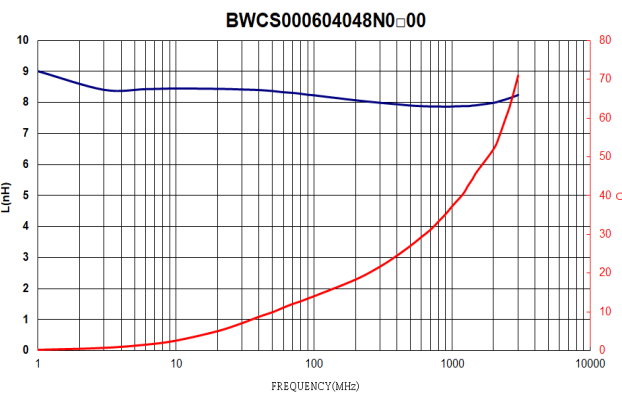
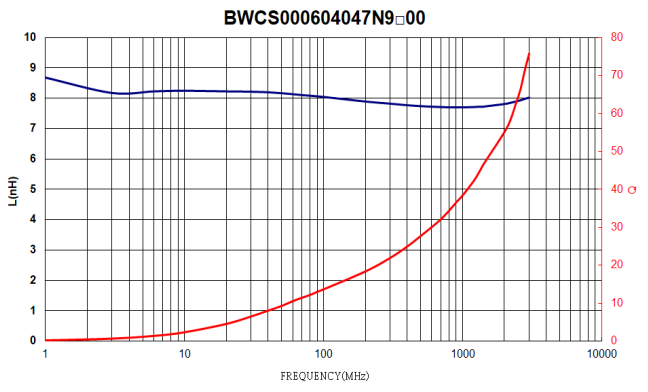
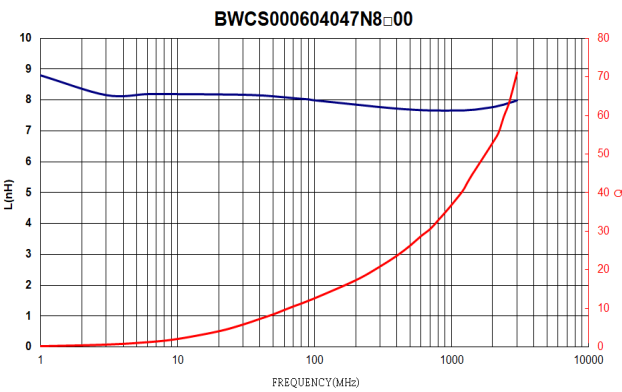
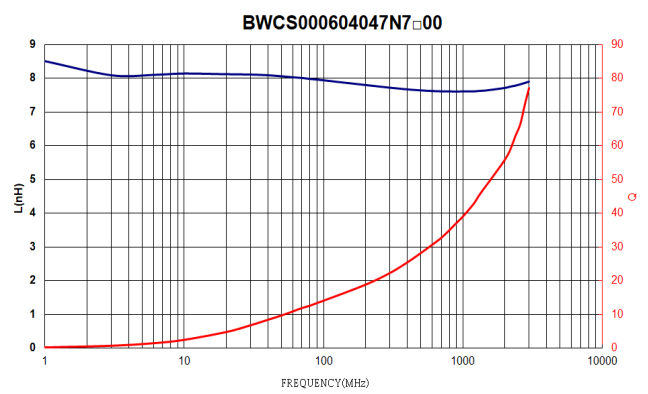
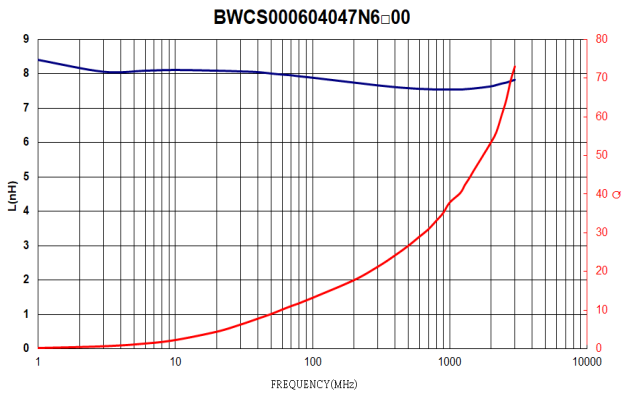
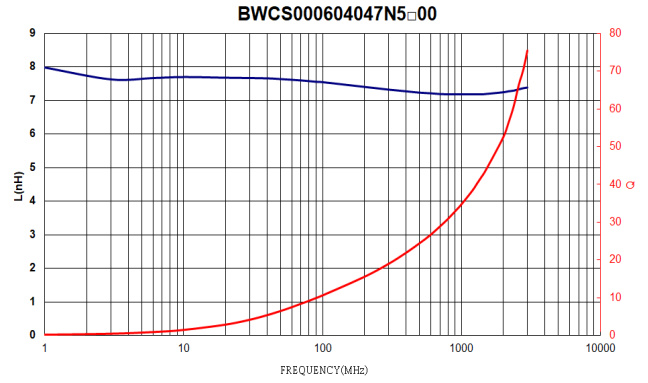
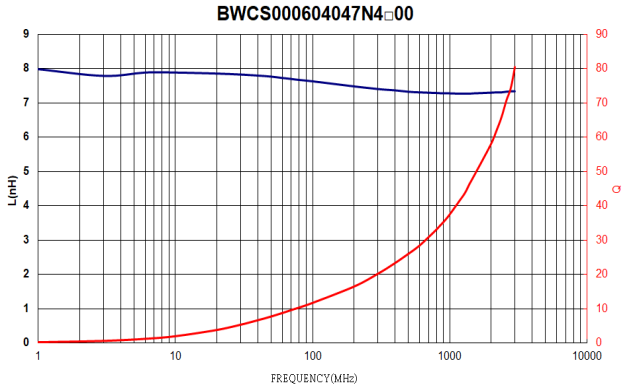

BWCS00060404 Series Specification

BWCS000604048N2□00

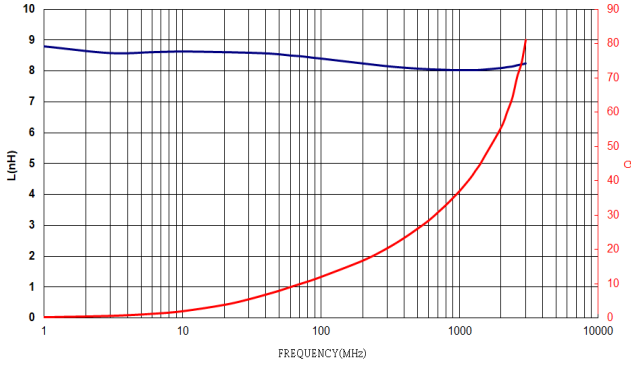

BWCS000604048N3□00

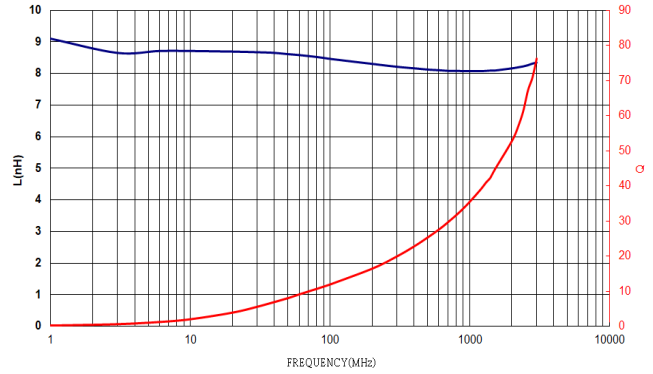

BWCS000604048N4□00

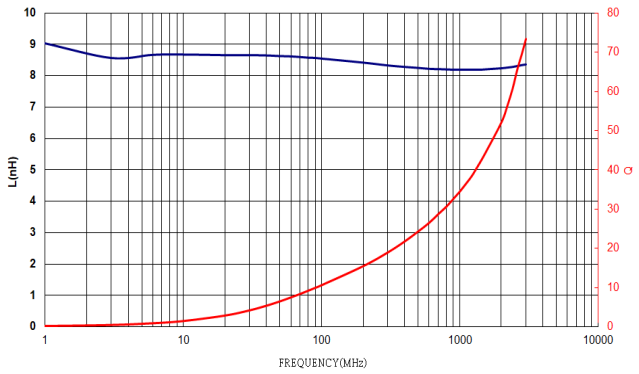

BWCS000604048N5□00

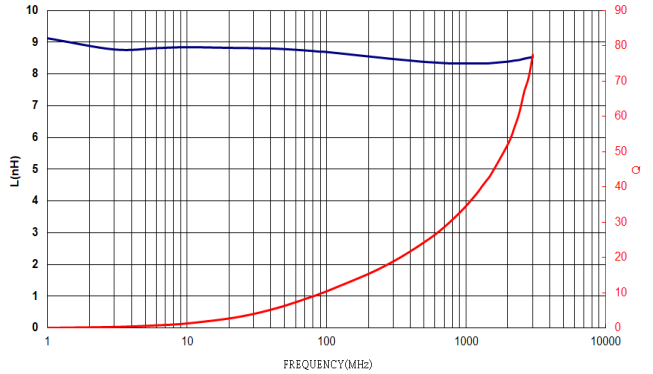

BWCS000604048N7□00

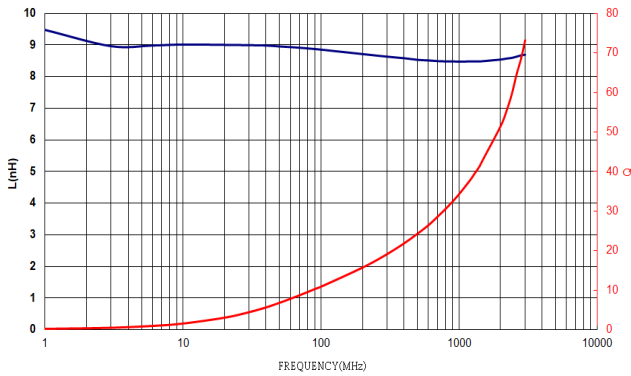

BWCS000604049N0□00

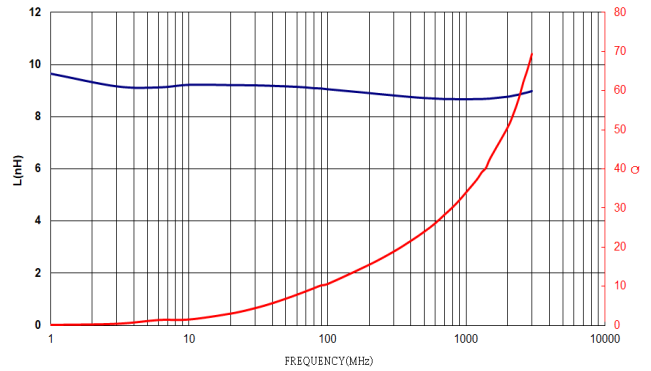

BWCS000604049N4□00

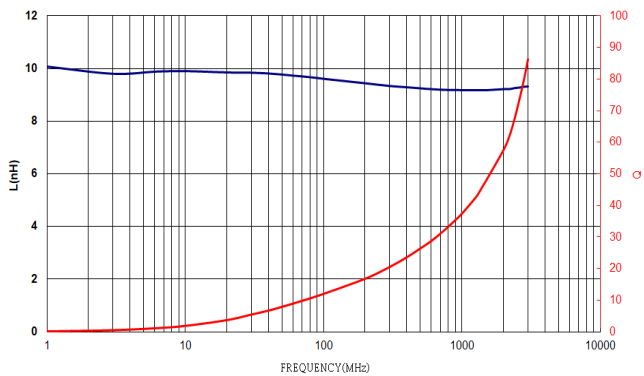

BWCS000604049N6□00

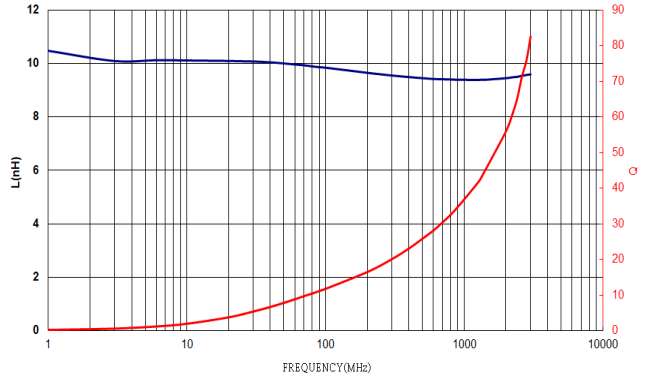

BWCS00060404 Series Specification

