

# HFD5-K MINIATURE 5TH GENERATION SIGNAL RELAY

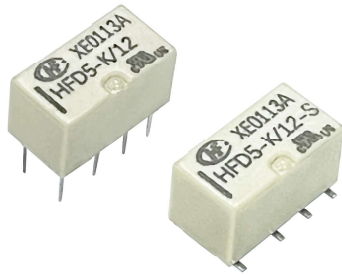

File No.: E133481

## Features

- An ideal alternative for small reed relays
- Operate/release (reset) time  $\leq 1.0\text{ms}$
- Bifurcated contacts
- 2 Form C configuration
- Products with electrical endurance  $\geq 5 \times 10^8$  ops available
- Low halogen products conforming to IEC61249-2-21 are available
- Both THT & SMT types available
- Single side stable and latching type available
- Smallest size in signal relay industry: 9.0(L) $\times$ 4.8(W) $\times$ 4.9(H) mm

RoHS compliant

## CONTACT DATA

Contact arrangement	2Z
Contact resistance	$\leq 100\text{m}\Omega$ (10mA 30mVDC)
Contact material	Ag alloy+Au plated
Contact rating (Res. load)	0.5A 30VDC, 1A 30VDC, 0.3A 125VAC
Max. switching current	2A(30VDC)
Max. switching voltage	125VAC/60VDC
Max. switching power	37.5VA/30W
Min. applicable load <sup>2)</sup>	10mV 10 $\mu$ A
Mechanical endurance	$5 \times 10^8$ 次
Electrical endurance <sup>3)</sup>	$1 \times 10^5$ OPS (85°C, 1s on: 9s off, NO or NC, 0.5A 30VDC) $1 \times 10^5$ OPS (85°C, 1s on: 9s off, NO or NC, 0.3A 125VAC) $3 \times 10^8$ OPS(AJ8) <sup>4)</sup> (40°C, 0.1s on: 0.1s off, Two sets of NO or NC in parallel <sup>5)</sup> , 10mA 5VDC)

- Notes:** 1) The data shown above are initial values.  
 2) Min. applicable load is reference value. Please perform the confirmation test with the actual load before production since reference value may change according to switching frequencies, environmental conditions and expected contact resistance and reliability.  
 3) Only typical loads are listed above. Other load specifications can be available upon request.  
 4) (AJ8) indicates products with electrical endurance  $\geq 3 \times 10^8$  OPS.  
 5) Two sets of NO or NC parallel wiring diagrams (bottom view) are as follows:

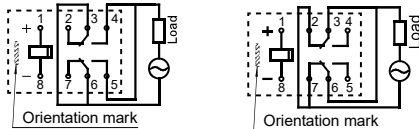

- 6) For low level and long durability applications, it is recommended to use two sets of NO or NC in parallel. If you need to use a single set of NO or NC, please contact our company.

## HIGH-FREQUENCY CHARACTERISTICS<sup>1)</sup>

Frequency <sup>2)</sup>	100MHz	900MHz
Insertion loss <sup>3)</sup>	0.03dB	0.3dB
V.SWR <sup>3)</sup>	1.05	1.4
Isolation <sup>3)</sup>	45dB	25dB

- Notes:** 1) The characteristic impedance of the measuring system is 50 $\Omega$ .  
 2) If there is a demand for frequencies higher than 1GHz, please contact us.  
 3) The data shown above are initial values.

## CHARACTERISTICS

Insulation resistance	1000M $\Omega$ (500VDC)	
Dielectric strength	Between open contacts	500VAC 1min
	Between coil & contacts	1000VAC 1min, 1500VAC 1min(413 specification only) <sup>2)</sup>
	Between contact sets	1000VAC 1min
Operate time (Set time)	$\leq 1.0\text{ms}$	
Release time (Reset time)	$\leq 1.0\text{ms}$	
Shock resistance	Functional	735m/s <sup>2</sup>
	Destructive	980m/s <sup>2</sup>
Vibration resistance	Functional	10Hz~55Hz 3.3mm DA
	Destructive	10Hz~55Hz 5.0mm DA
Humidity	5% to 85%RH	
Ambient temperature	-40°C to 85°C	
Termination	THT、SMT	
Unit weight	Approx. 0.5g	
Moisture sensitivity levels (Only for SMT type, JEDEC-STD-020)	MSL-3	
Construction	Plastic sealed	

- Notes:** 1) The data shown above are initial values;  
 2) (413) indicates products with dielectric withstand voltage between coil and contact  $\geq 1500\text{VAC}$  1 min.

## COIL

Coil power	Single side stable	See table "COIL DATA"
	1 coil latching	See table "COIL DATA"
Temperature rise	$\leq 50\text{K}$ (0.5A Load, at 85°C)	

## SAFETY APPROVAL RATINGS

UL/CUL	Ag alloy+Au plated	0.5A 30VDC 1A 30VDC 0.3A 125VAC
--------	--------------------	---------------------------------------

- Notes:** 1) Only some typical rating are listed above. If more details are required, please contact us.



HONGFA RELAY

ISO9001, IATF16949, ISO14001, ISO45001, IECQ QC 080000, ISO/IEC 27001 CERTIFIED

2025 Rev.2.00

## COIL DATA

23°C

### Single side stable

Coil Code	Nominal Voltage VDC	Initial Pick-up Voltage <sup>2)</sup> VDC max.	Initial Drop-out Voltage <sup>1)</sup> VDC max.	Coil Resistance $\Omega$	Nominal current mA	Nominal Power mW approx	Max. Voltage VDC <sup>5)</sup>
HFD5-K/1.5	1.5	1.13	0.15	16×(1±10%)	93	140	2.3
HFD5-K/2.4	2.4	1.80	0.24	41×(1±10%)	58	140	3.6
HFD5-K/3 <sup>3)</sup>	3.0	2.25	0.30	64.3×(1±10%)	47	140	4.5
HFD5-K/4.5	4.5	3.38	0.45	145×(1±10%)	31	140	6.8
HFD5-K/5 <sup>3)</sup>	5.0	3.75	0.50	179×(1±10%)	28	140	7.5
HFD5-K/6	6.0	4.50	0.60	257×(1±10%)	23	140	9.0
HFD5-K/9	9.0	6.75	0.90	579×(1±10%)	16	140	13.5
HFD5-K/12	12.0	9.00	1.20	1029×(1±10%)	12	140	18.0
HFD5-K/24	24.0	18.00	2.40	4114×(1±10%)	6	140	36.0

### 1 coil latching

Coil Code	Nominal Voltage VDC	Initial Pick-up Voltage <sup>2)</sup> VDC max.	Initial Drop-out Voltage <sup>1)</sup> VDC max.	Coil Resistance $\Omega$	Nominal current mA	Nominal Power mW approx	Max. Voltage VDC <sup>5)</sup>
HFD5-K/1.5-L	1.5	1.13	1.13	16×(1±10%)	93	140	2.3
HFD5-K/2.4-L	2.4	1.80	1.80	41×(1±10%)	58	140	3.6
HFD5-K/3-L <sup>3)</sup>	3.0	2.25	2.25	64.3×(1±10%)	47	140	4.5
HFD5-K/4.5-L	4.5	3.38	3.38	145×(1±10%)	31	140	6.8
HFD5-K/5-L <sup>3)</sup>	5.0	3.75	3.75	179×(1±10%)	28	140	7.5
HFD5-K/6-L	6.0	4.50	4.50	257×(1±10%)	23	140	9.0
HFD5-K/9-L	9.0	6.75	6.75	579×(1±10%)	16	140	13.5
HFD5-K/12-L	12.0	9.00	9.00	1029×(1±10%)	12	140	18.0
HFD5-K/24-L	24.0	18.00	18.00	4114×(1±10%)	6	140	36.0

**Notes:**1)The data shown above are initial values.

2) Initial Pick-up voltage is the factory value of the relay.

To supply rated step voltage to coil is the foundation of relay proper operation. Please make sure the applied voltage to the coil reach at rated values.

Please refer to the typical diagram below for single side stable relay. The "V\_coil" is the rated voltage.:

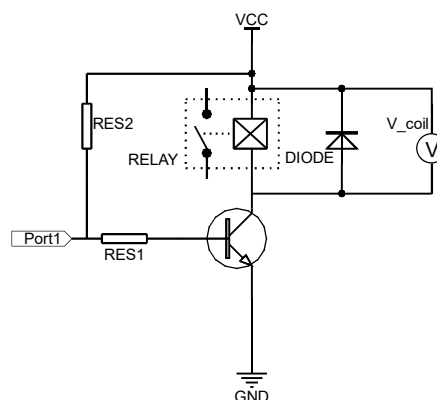

3) In case 5V of transistor drive circuit, it is recommended to use 4.5V type relay, and 3V to use 2.4V type relay.

4) For monostable relays, if you need to drop down voltage and hold mode after reliably operating, make sure that the effective value of holding voltage is not less than 60% of the rated voltage.

5) Maximum voltage refers to the maximum voltage which relay coil could endure in a short period of time.

6) When user's requirements can't be found in the above table, special order allowed.

7) During the relay pick-up or drop-out processes, there are stages of contact pressure change, contact vibration and unstable contact etc. When the voltage applied to coil is gradually changed, it will lengthen the unstable stage and affect relay endurance. To reduce this influence, please apply step voltage (switching circuit) to relay coil.

## ORDERING INFORMATION

Type	HFD5-K/	12	-L	S	R	(XXX)
Coil voltage	1.5, 2.4, 3, 4.5, 5, 6, 9, 12, 24VDC					
Sort	L: 1 coil latching Nil: Single side stable					
Terminal type	S: Standard SMT S1: Short terminal SMT Nil: THT <sup>1)</sup>					
Packing style	R: Tape and reel packing (Only for SMT type) <sup>2)</sup> Nil: Tube packing(Only for THT type)					
Special code	<b>XXX:</b> Customer special requirement <b>Nil:</b> Standard For instance: Product with 825 suffix is applicable to low level load applications, such as testing, medical treatment, communication, etc. Product with AQ8 suffix is indicate electrical endurance $\geq 5 \times 10^8$ OPS Product with 413 suffix is indicate dielectric withstand voltage between coil and contact 1500VAC 1 min.					

- Notes: 1) Please use wave soldering or manual soldering for straight-in relay. If you need reflow welding, please confirm the feasibility with us.  
 2) R type (tape and reel) packing is moisture-proof which meets requirement of MSL-3. Please choose R type packing for SMT products. For R type, the letter "R" will only be printed on packing tag but not on relay cover. Tube packing is normally not available for SMT products unless specially requested by customer. But please note that tube packing is not moisture-proof so please bake the products before use according to description of Notice 11 herewith. In addition, tube packaging will be adopted when the ordering quantity of R type is equal to or less than 100 pieces unless otherwise specified.  
 3) When coil sort, terminal type or packing style are needed, please add "-" after coil voltage is selected. For instance, HFD5-K/12-SR.  
 4) The customer special requirement express as special code after evaluating by Hongfa.

## OUTLINE DIMENSIONS, WIRING DIAGRAM AND PC BOARD LAYOUT

Unit: mm

Outline Dimensions

PCB Layout(Bottom view)

THT

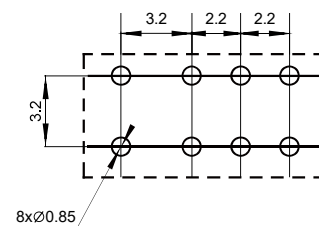
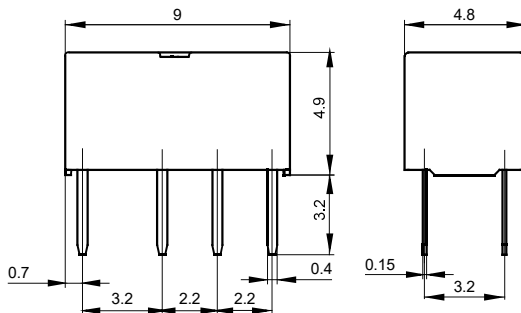

S type: Standard SMT

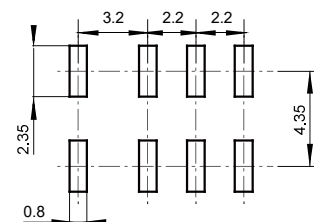
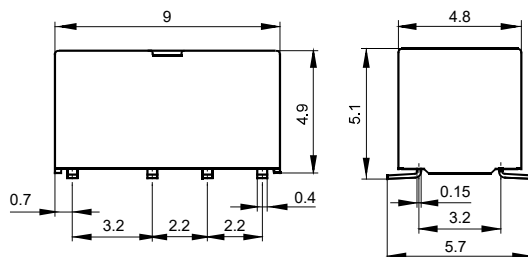

# OUTLINE DIMENSIONS, WIRING DIAGRAM AND PC BOARD LAYOUT

Unit: mm

## Outline Dimensions

## PCB Layout(Bottom view)

S1: Short terminal SMT

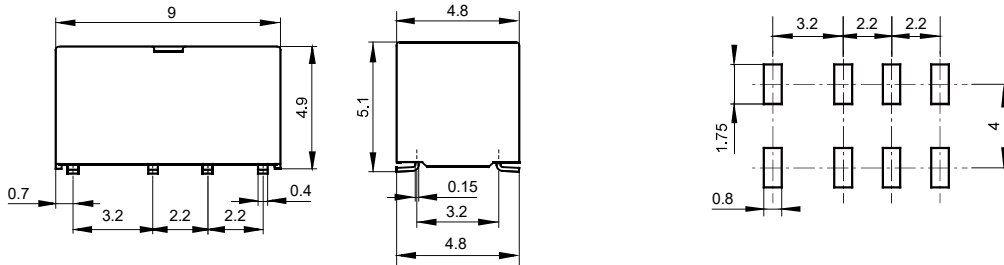

## Wiring Diagram(Bottom view)

### Single side stable

### 1 coil latching

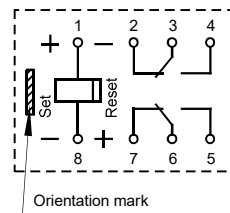
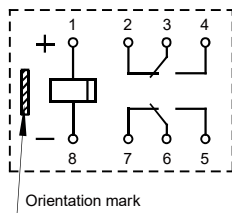

No energized condition

Reset condition

## Pin Layout

### Single side stable & 1 coil latching

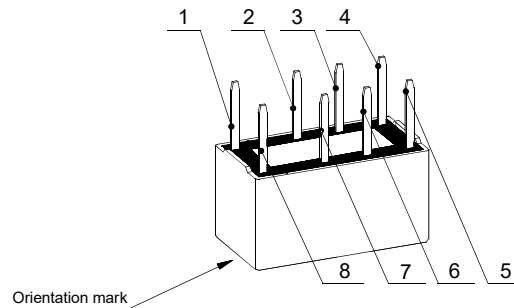

- Remark: 1) In case of no tolerance shown in outline dimension: outline dimension  $\leq 1\text{mm}$ , tolerance should be  $\pm 0.2\text{mm}$ ; outline dimension  $> 1\text{mm}$  and  $\leq 5\text{mm}$ , tolerance should be  $\pm 0.3\text{mm}$ ; outline dimension  $> 5\text{mm}$ , tolerance should be  $\pm 0.4\text{mm}$ .  
 2) The tolerance without indicating for PCB layout is always  $\pm 0.1\text{mm}$ .  
 3) The pin dimension of the product outline drawing is the size before tinning (it will become larger after tinning), and the mounting hole size is the recommended design size of the PCB board hole. The specific PCB board hole design size can be mapped and adjusted according to the actual product.

# TAPE PACKING

Unit: mm

## Direction of Relay Insertion

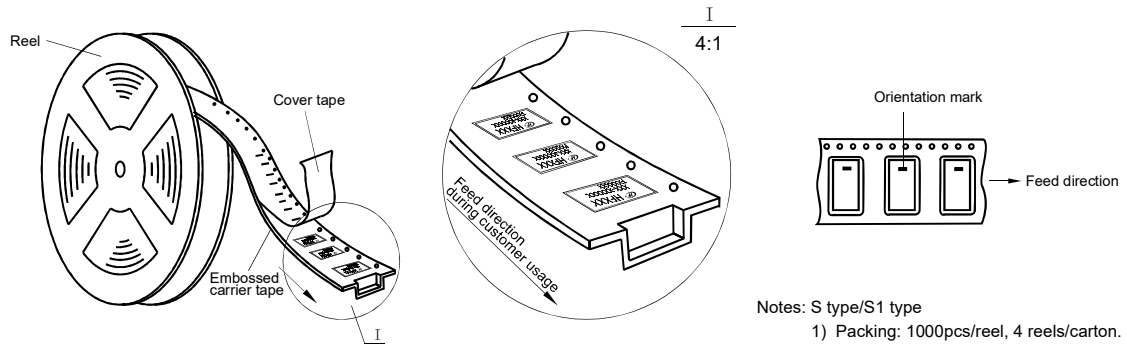

- Notes: S type/S1 type
- 1) Packing: 1000pcs/reel, 4 reels/carton.
  - 2) MOQ for reel packing is 1000pcs.

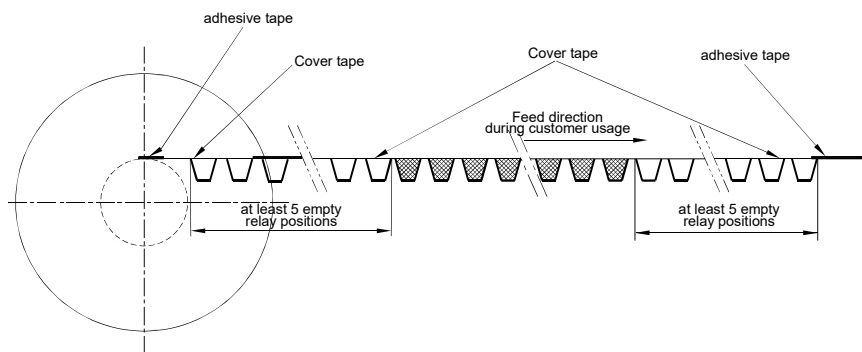

## Reel Dimensions

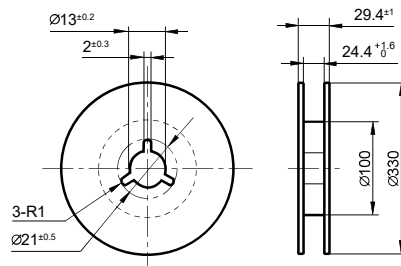

## Tape Dimensions (S type: Standard SMT, S1 type: Short terminal SMT)

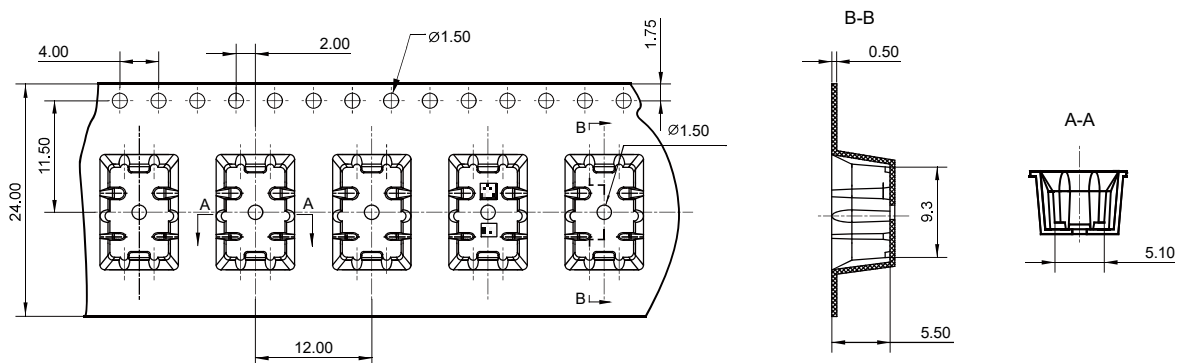

## HIGH FREQUENCY CHARACTERISTICS CURVES



- Remark: 1) Ambient temperature conditions is 23°C;  
 2) The data shown above are initial values.  
 3) The high-frequency characteristics will vary depending on the PCB board. Please be sure to check performance parameters including durability in actual equipment before use.  
 4) Test model and specification: HFD5-K/XX-SR, test instrument: Keysight E5071C network analyzer, the characteristic impedance of the measurement system is 50Ω.

## CHARACTERISTIC CURVES

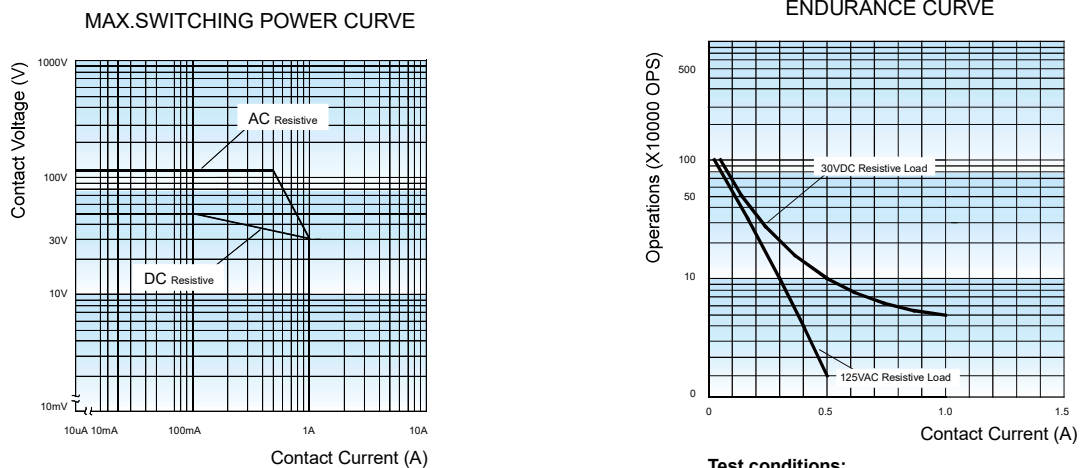

**Test conditions:**  
 Resistive load, 1s on 9s off.

## REFLOW WELDING, TEMPERATURE ON PCB BOARD RECOMMENDED WELDING TEMPERATURE (Only for SMT version)

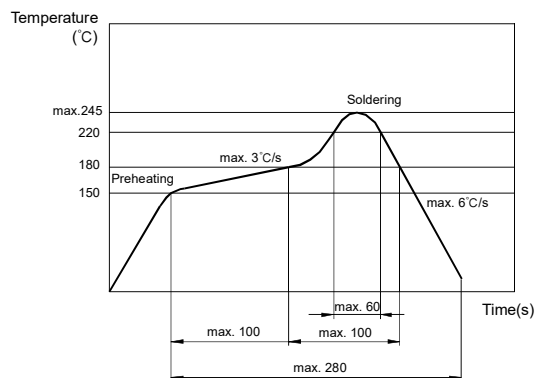

## Notice

- 1) This relay is highly sensitive polarized relay, if correct polarity is not applied to the coil terminals, the relay does not operate properly.
- 2) To avoid using relays under strong magnetic field which will change the parameters of relays such as pick-up voltage and drop-out voltage.
- 3) Relay is on the "reset" status when being released from stock, with the consideration of shock risen from transit and relay mounting, it should be changed to the "set" status when application(connecting to the power supply). Please reset the relay to "set" or "reset" status on request.
- 4) Energizing coil with rated voltage is basic for normal operation of a relay, please make sure the energized voltage to relay coil have reached the rated voltage. Regarding latching relay, in order to maintain the "set" or "reset" status, impulse width of the rated voltage applied to coil should be more than 5 times of "set" or "reset" time.
- 5) For a monosteady state relay, after the relay is reliably operated, if it needs to be kept under pressure, make sure that the effective value of the voltage is not less than 60 % of the rated voltage;
- 6) The relay may be damaged because of falling or when shocking conditions exceed the requirement.
- 7) For SMT products, validation with real application should be done before your series production, if the reflow-soldering temperature curve is out of our recommendation. Generally, two-time reflow-soldering is not recommended for the relay. However, if two-time reflow-soldering is required, a 60-min. interval should be guaranteed and a validation should be done before production.
- 8) Please use wave soldering or manual soldering for straight-in relay. If you need reflow welding, please confirm the feasibility with us.
- 9) Contact is recommended for suitable condition and specifications if water cleaning or surface process is involved in assembling relays on PCB.
- 10) Regarding the plastic sealed relay, we should leave it cooling naturally until below 40°C after welding, then clean it and deal with coating, remarkably the temperature of solvents should also be controlled below 40°C. Please avoid cleaning the relay by ultrasonic, avoid using the solvents like gasoline, Freon, and so on, which would affect the configuration of relay or influence the environment.
- 11) Relays packaged in moisture barrier bags meet MSL-3 requirements. The relays should be stored at ambient conditions of  $\leq 30^{\circ}\text{C}$  and  $\leq 60\%$  RH after they are removed from their packaging, and should be used within 168 hours. If the relays cannot be used within 168 hours, please repack them or store them in a drying oven at  $25^{\circ}\text{C}\pm 5^{\circ}\text{C}$ ,  $\leq 10\%$  RH. Otherwise, relays may be subjected to a soldering test to check their performance, or they may be used after keeping them in an oven for 72 hours at with  $50^{\circ}\text{C}\pm 5^{\circ}\text{C}$ ,  $\leq 30\%$  RH.
- 12) When applied with continuous current, the heat from relay coil will age its isolation. Thus, please do not ground connected the coil to reduce electrical erosion if possible. And please provide protection circuit to avoid broken wire and losses.
- 13) Please make sure that there are no silicon-based substances (such as silicon rubber, silicone oil, silicon-based coating agents, silicon fillers, etc.) around the relay, because it will generate silicon-containing volatile gas, which may cause poor contact in case of silicon-containing volatile gas sticking on contact.
- 14) About preferable condition of operation, storage and transportation, please refer to "Explanation to terminology and guidelines of relay."
- 15) During the relay pick-up or drop-out processes, there are stages of contact pressure change, contact vibration and unstable contact etc. When the voltage applied to coil is gradually changed, it will lengthen the unstable stage and affect relay endurance. To reduce this influence, please apply step voltage (switching circuit) to relay coil.

## Disclaimer

The specification is for reference only. See to "Terminology and Guidelines" for more information. Specifications subject to change without notice. We could not evaluate all the performance and all the parameters for every possible application. Thus the user should be in a right position to choose the suitable product for their own application. If there is any query, please contact Hongfa for the technical service. However, it is the user's responsibility to determine which product should be used only.