

Data Sheet | Item Number: 2091-1528/002-000

1-conductor male connector; Push-in CAGE CLAMP®; 1.5 mm²; Pin spacing 3.5 mm; 8-pole; Integrated release lever; 1,50 mm²; light gray

<https://www.wago.com/2091-1528/002-000>



Color: ■ light gray

Similar to illustration

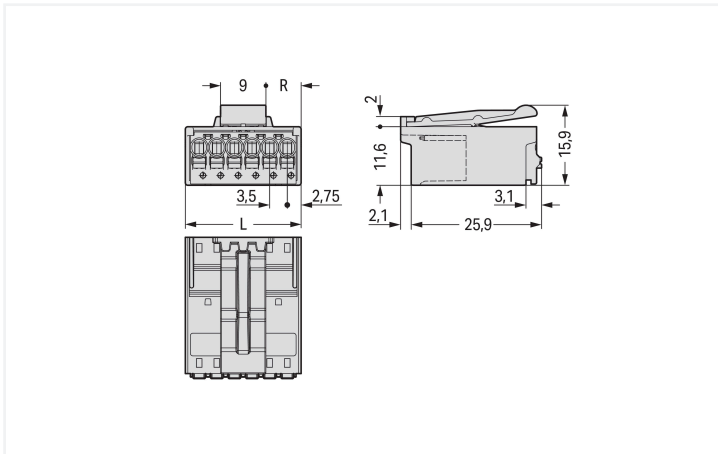
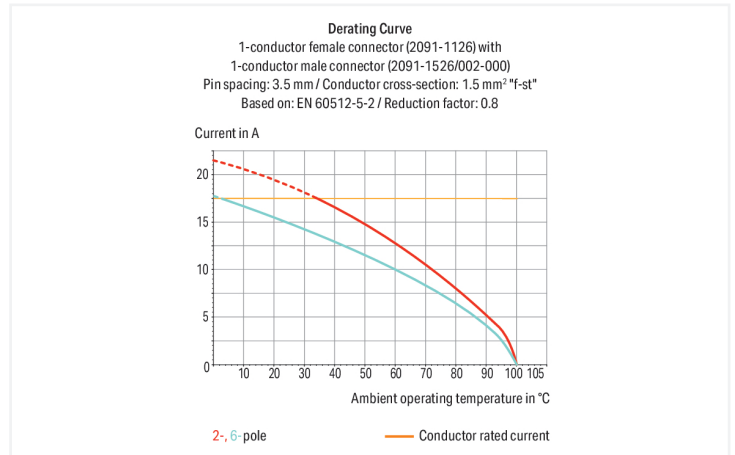

Dimensions in mm

$L = (\text{pole no.} \times \text{pin spacing}) + 2 \text{ mm}$ Even pole number $R = (L - 9 \text{ mm}) : 2$ Odd pole number $R = (L - 12.5 \text{ mm}) : 2$

Male connector, 2091 Series, with 3.5 mm pin spacing

Error-free electrical installations are guaranteed with this male connector (item number 2091-1528/002-000). Conductors can only be connected to this male connector if their strip length is between 8 and 9 mm. Featuring one conductor terminal along with Push-in CAGE CLAMP®, this product outperforms the competition. Push-in CAGE CLAMP® connection technology is ideal for connecting all conductor types. It allows direct insertion of both solid and fine-stranded conductors with ferrules without the need for tools—all thanks to its pluggable design. The dimensions are (30 x 15.9 x 28) mm (width x height x depth). This male connector is suitable for conductor cross sections ranging from 0.2 mm² to 1.5 mm².

Tin is used for coating the contact surfaces.

Notes

Safety Information

The **picoMAX® Pluggable Connection System** includes connectors without breaking capacity in accordance with DIN EN 61984. When used as intended, these connectors must not be connected/disconnected when live or under load. When used as intended, these connectors must not be connected/disconnected when live or under load. The circuit design should ensure header pins, which can be touched, are not live when unmated.

Safety information 2

The use of ferrules is recommended for applications with higher requirements.

To prevent excessive force on the clamping point, effective cable strain relief must be used.

Variants:

Direct marking

Other versions (or variants) can be requested from WAGO Sales or configured at <https://configurator.wago.com/>.

Electrical data

| Ratings per | IEC/EN 60664-1 | | | Approvals per | UL 1059 | | |
|---------------------------------|----------------|--------|--------|---------------|-----------|---|-------|
| | III | III | II | | Use group | B | C |
| Overvoltage category | III | III | II | Use group | B | C | D |
| Pollution degree | 3 | 2 | 2 | Rated voltage | 300 V | - | 300 V |
| Nominal voltage | 160 V | 160 V | 320 V | Rated current | 10 A | - | 10 A |
| Rated impulse withstand voltage | 2.5 kV | 2.5 kV | 2.5 kV | | | | |
| Rated current | 10 A | 10 A | 10 A | | | | |

Connection Data

| | | | | |
|----------------------------|---|---|---|---|
| Clamping units | 8 | Connection 1 | Connection technology | Push-in CAGE CLAMP® |
| Total number of potentials | 8 | | Actuation type | Push-button |
| Number of connection types | 1 | | Actuation direction 1 | Operation parallel to conductor entry |
| Number of levels | 1 | | Solid conductor | 0.2 ... 1.5 mm ² / 24 ... 14 AWG |
| | | Fine-stranded conductor | 0.2 ... 1.5 mm ² / 24 ... 14 AWG | |
| | | Fine-stranded conductor; with insulated ferrule | 0.25 ... 0.75 mm ² | |
| | | Fine-stranded conductor; with uninsulated ferrule | 0.25 ... 1.5 mm ² | |
| | | Strip length | 8 ... 9 mm / 0.31 ... 0.35 inches | |
| | | Pole number | 8 | |

Physical data

| | |
|-------------|------------------------|
| Pin spacing | 3.5 mm / 0.138 inches |
| Width | 30 mm / 1.181 inches |
| Height | 15.9 mm / 0.626 inches |
| Depth | 28 mm / 1.102 inches |

Mechanical data

| | |
|--------------------------|-----|
| Variable coding | Yes |
| Anti-rotation protection | Yes |

Plug-in connection

| | |
|--------------------------------------|---------------------|
| Contact type (pluggable connector) | Male connector/plug |
| Connector (connection type) | for conductor |
| Mismating protection | No |
| Plugging without loss of pin spacing | Yes |
| Locking of plug-in connection | Locking latch |

Material data

| | |
|------------------------------------|--|
| Note (material data) | Information on material specifications can be found here |
| Color | light gray |
| Material group | I |
| Insulation material (main housing) | Polyphthalamide (PPA GF) |
| Flammability class per UL94 | V0 |
| Clamping spring material | Chrome-nickel spring steel (CrNi) |
| Contact material | Electrolytic copper (E _{Cu}) |
| Contact Plating | Tin |
| Fire load | 0.089 MJ |
| Weight | 7.8 g |

Environmental requirements

| | |
|-------------------------|-----------------|
| Limit temperature range | -60 ... +100 °C |
| Processing temperature | -35 ... +60 °C |

Commercial data

| | |
|-----------------------|-------------------------|
| Product Group | 26 (picoMAX Connectors) |
| PU (SPU) | 100 pcs |
| Packaging type | Box |
| Country of origin | DE |
| GTIN | 4050821161387 |
| Customs tariff number | 85366930000 |

Product Classification

| | |
|-------------|----------------------|
| UNSPSC | 39121409 |
| eCl@ss 10.0 | 27-14-11-06 |
| eCl@ss 9.0 | 27-14-11-06 |
| ETIM 9.0 | EC001284 |
| ETIM 10.0 | EC001284 |
| ECCN | NO US CLASSIFICATION |

Environmental Product Compliance

| | |
|------------------------|-------------------------|
| RoHS Compliance Status | Compliant, No Exemption |
|------------------------|-------------------------|

Approvals / Certificates

General approvals



| Approval | Standard | Certificate Name |
|---------------------------------------|---------------|------------------|
| CB DEKRA Certification B.V. | IEC 61984 | NL-89884 |
| CSA CSA Group | C22.2 | 2362521 |
| CSA DEKRA Certification B.V. | C22.2 No. 158 | 2362521 |
| KEMA/KEUR DEKRA Certification B.V. | EN 61984 | 71-129873 |
| UR Underwriters Laboratories Inc. | UL 1059 | E45172 |

Downloads

Environmental Product Compliance

Compliance Search

Environmental Product Compliance
2091-1528/002-000



Documentation

Additional Information

Technical Section

03.04.2019

pdf
2027.26 KB



CAD/CAE-Data

CAD data

2D/3D Models
2091-1528/002-000



CAE data

ZUKEN Portal
2091-1528/002-000



1 Compatible Products

1.1 System counterpart

1.1.1 Female connector/socket



Item No.: 2091-1128

1-conductor female connector; push-button; Push-in CAGE CLAMP®; 1.5 mm²; Pin spacing 3.5 mm; 8-pole; 1,50 mm²; light gray



Item No.: 2091-1108

1-conductor female connector; push-button; Push-in CAGE CLAMP®; 1.5 mm²; Pin spacing 3.5 mm; 8-pole; Gripping plate; 1,50 mm²; light gray



Item No.: 2091-1108/000-1000

1-conductor female connector; push-button; Push-in CAGE CLAMP®; 1.5 mm²; Pin spacing 3.5 mm; 8-pole; Gripping plate; direct marking; 1,50 mm²; light gray



Item No.: 2091-1108/000-5000

1-conductor female connector; push-button; Push-in CAGE CLAMP®; 1.5 mm²; Pin spacing 3.5 mm; 8-pole; Gripping plate; direct marking; 1,50 mm²; light gray

1.1.1 Female connector/socket



Item No.: 2091-1328/200-000

THR female header; angled; Pin spacing 3.5 mm; 8-pole; 0.4 x 0.9 mm solder pin; light gray



Item No.: 2091-1308/200-000

THR female header; straight; Pin spacing 3.5 mm; 8-pole; 0.4 x 0.9 mm solder pin; light gray



Item No.: 2091-1328

THT female header; angled; Pin spacing 3.5 mm; 8-pole; 0.4 x 0.9 mm solder pin; light gray



Item No.: 2091-1308

THT female header; straight; Pin spacing 3.5 mm; 8-pole; 0.4 x 0.9 mm solder pin; light gray

1.2 Optional Accessories

1.2.1 Coding

1.2.1.1 Coding



Item No.: 2091-1610

Coding key carrier; suitable for 3.5 mm pin spacing; orange

1.2.2 Ferrule

1.2.2.1 Ferrule



Item No.: 216-301

Ferrule; Sleeve for 0.25 mm² / AWG 24; insulated; electro-tin plated; yellow



Item No.: 216-131

Ferrule; Sleeve for 0.25 mm² / AWG 24; uninsulated; electro-tin plated; silver-colored



Item No.: 216-302

Ferrule; Sleeve for 0.34 mm² / 22 AWG; insulated; electro-tin plated; light turquoise



Item No.: 216-132

Ferrule; Sleeve for 0.34 mm² / 22 AWG; uninsulated; electro-tin plated



Item No.: 216-101

Ferrule; Sleeve for 0.5 mm² / AWG 22; un-insulated; electro-tin plated; silver-colored



Item No.: 216-202

Ferrule; Sleeve for 0.75 mm² / 18 AWG; insulated; electro-tin plated; gray



Item No.: 216-102

Ferrule; Sleeve for 0.75 mm² / 18 AWG; un-insulated; electro-tin plated; silver-colored



Item No.: 216-122

Ferrule; Sleeve for 0.75 mm² / 18 AWG; un-insulated; electro-tin plated; silver-colored



Item No.: 216-203

Ferrule; Sleeve for 1 mm² / AWG 18; insulated; electro-tin plated; red



Item No.: 216-103

Ferrule; Sleeve for 1 mm² / AWG 18; un-insulated; electro-tin plated



Item No.: 216-204

Ferrule; Sleeve for 1.5 mm² / AWG 16; insulated; electro-tin plated; black



Item No.: 216-104

Ferrule; Sleeve for 1.5 mm² / AWG 16; un-insulated; electro-tin plated; silver-colored

1.2.3 Test and measurement

1.2.3.1 Testing accessories



Item No.: 735-500

WAGO Test pin; 1 mm Ø; 30 V AC / 60 V DC; CAT0; 1 A; 6 mm un-insulated; Test lead for soldering up to 0,5mm²

1.2.4 Tool

1.2.4.1 Operating tool



Item No.: 210-719

Operating tool; Blade: 2.5 x 0.4 mm; with a partially insulated shaft