

| REVISIONS | | | | | |
|-----------|-----|----------------------|-----------|-----|------|
| P | LTR | DESCRIPTION | DATE | DWN | APVD |
| A | | PRODUCTION RELEASE | 25NOV2025 | NMP | PS |
| AI | | PROJECT NUMBER ADDED | 13JAN2026 | KA | NMP |
| | | | | | |

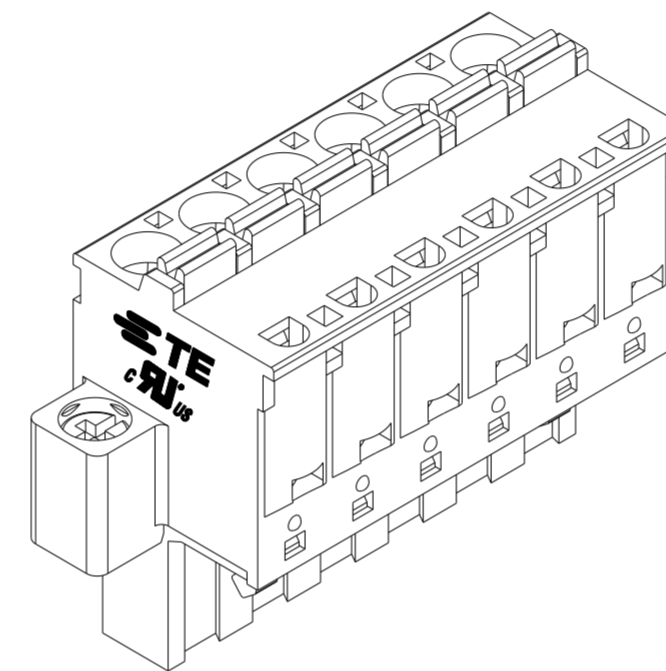
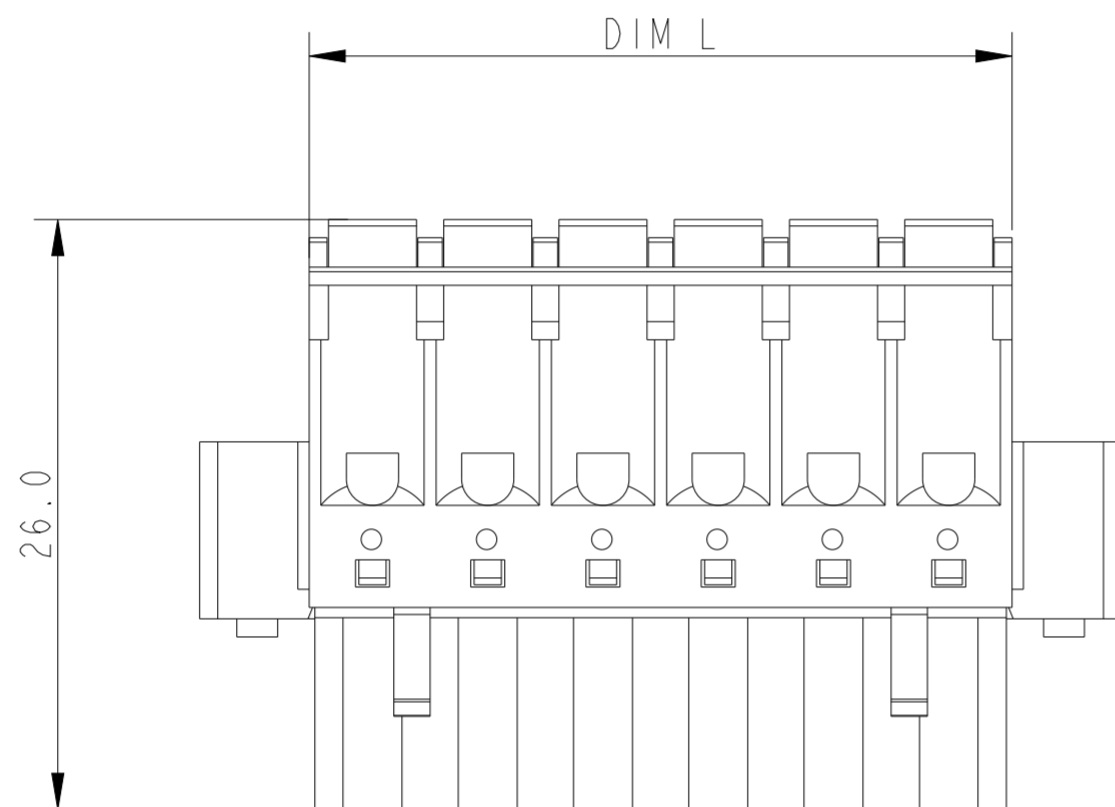
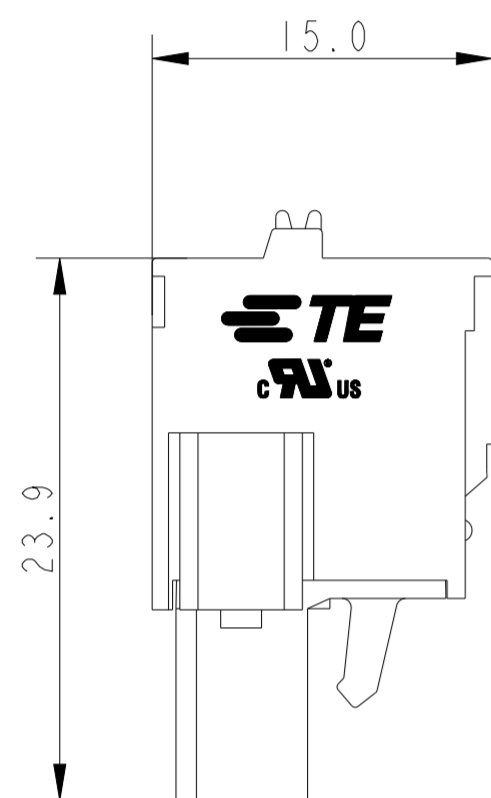
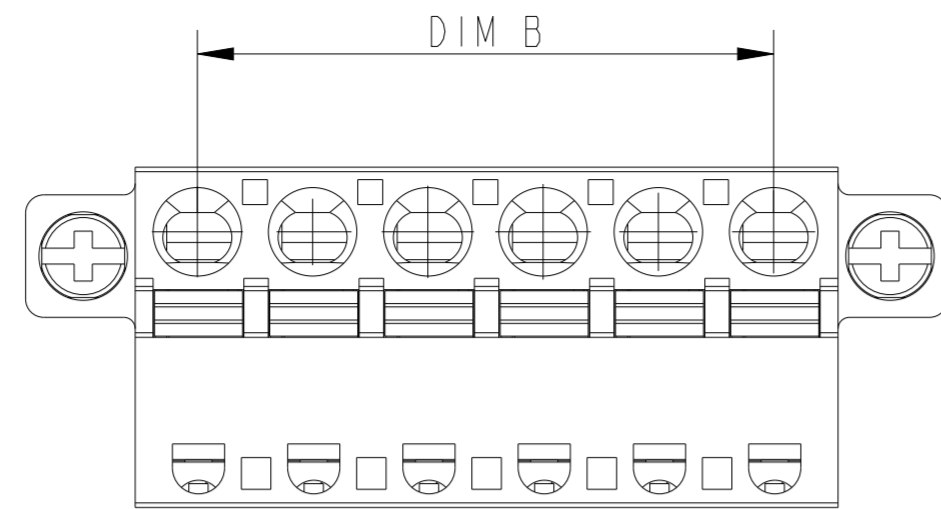

2842520-6 AS SHOWN

NOTES:

- △ MATERIALS AND FINISH
 HOUSING : PA 66, UL 94 V-0, COLOR GREEN.
 PUSH BUTTON : POM UL94-HB, COLOR ORANGE.
 CONTACT : PHOSPHOR BRONZE, TIN PLATED
 SPRING : STAINLESS STEEL
 SCREW FLANGE : STEEL, ZINC PLATED
- ELECTRICAL:
 WIRE RANGE : 26-12 AWG
 RATED VOLTAGE : 300V
 RATED CURRENT : 10A
 INSULATION RESISTANCE : >1000 M Ω (500V DC)
 INSULATION WITHSTANDING VOLTAGE: AC 1600V/MIN

STRIPPING LENGTH : 8-9 mm
- OPERATING TEMPERATURE RANGE : -40°C TO +115°C.
- △ NOT CUMULATIVE TOLERANCE
- PARTS UPTO 24 POSITIONS ARE AVAILABLE UPON REQUEST

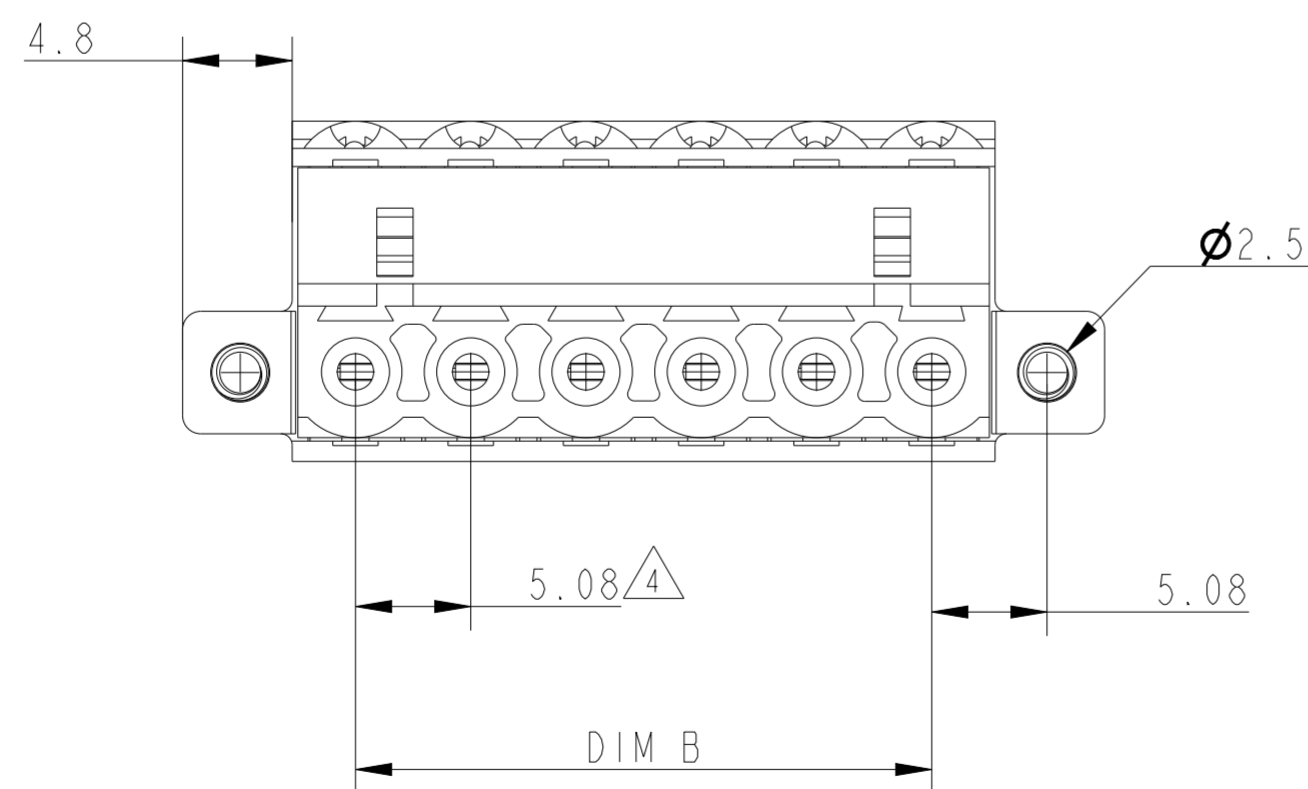

| | | | | | |
|---------------------|-------|---------------------|-------|--------------------|-------------|
| ±0.20 | 45.72 | ±0.25 | 51.30 | 10 | 1-2842520-0 |
| | 40.64 | | 46.22 | 9 | 2842520-9 |
| | 35.56 | | 41.14 | 8 | 2842520-8 |
| | 30.48 | | 36.06 | 7 | 2842520-7 |
| ±0.15 | 25.40 | ±0.20 | 30.98 | 6 | 2842520-6 |
| | 20.32 | | 25.90 | 5 | 2842520-5 |
| | 15.24 | | 20.82 | 4 | 2842520-4 |
| | 10.16 | | 15.74 | 3 | 2842520-3 |
| | 5.08 | | 10.66 | 2 | 2842520-2 |
| TOLERANCE FOR DIM B | DIM B | TOLERANCE FOR DIM L | DIM L | NO OF POSITIONS(P) | PART NUMBER |

| | | | | | |
|--|--|------------------|---------------------|---|-----------|
| THIS DRAWING IS A CONTROLLED DOCUMENT. | | DWN | 9SEP2025 | | |
| DIMENSIONS: mm | | CHK | 10SEP2025 | | |
| TOLERANCES UNLESS OTHERWISE SPECIFIED: | | APVD | 10SEP2025 | | |
| 0 PLC ±0.50 1 PLC ±0.30 2 PLC ±0.10 3 PLC ± 4 PLC ± ANGLES ±° FINISH SEE NOTES | | NAME | PRASHANTH SURATHKAL | | |
| MATERIAL SEE NOTES | | PRODUCT SPEC | 108-161183 | SPRING TYPE TERMINAL BLOCK, PLUG, SR W/ FLANGE, 5.08MM PITCH, GREEN | |
| | | APPLICATION SPEC | 114-160803 | SIZE | A2 |
| | | WEIGHT | - | CAGE CODE | 00779 |
| | | CUSTOMER DRAWING | | DRAWING NO | C-2842520 |
| | | SCALE | 3:1 | SHEET | 1 OF 1 |
| | | REV | AI | | |