

RoHS & Halogen Free & REACH Compliance.

SPECIFICATION FOR APPROVAL

Customer	_____		
Customer P/N	_____		
Drawing no.	_____		
Quantity	1	Pcs.	Date 2025/12/30
Pulse P/N	AMMB001010401R0MS1		

Automotive Grade Inductor		
Halogen Free RoHS Compliant REACH Compliant Lead Free Solders AEC-Q200		
Chilisin Electronics Corp No. 270, Nanfeng Rd., Pingzhen Dist., Taoyuan City 324019, Taiwan (R.O.C.) Tel : +886-3- 415-9111	Chilisin Electronics (Kunshan) Limited No. 240, Binjiang South Road, Zhangpu Town, Kunshan City, Jiangsu Province Tel : 0512-57450881	
Chilisin Electronics (Vietnam) Limited No 143 - 145, Road No 10, VSIP Hai Phong, Lap Le Commune, Thuy Nguyen Dist, Haiphong City, Vietnam Tel : 84-316 255 688	HuNan Chilisin Electronics Technology Co., Ltd No.8 Industrial Ave., Yuanling Industrial Development Dist. Yuanling County, Huaihua City, Hunan Province, China -419600 Tel : 86-745-867-5882	
Drawn by	Checked by	Approved by
Renee Dai	Wayne Wu	Mark Chung

AMMB00101040 Series Specification

AEC-Q200

1 Scope This specification applies to large current and low loss SMD power inductor

2 Part numbering

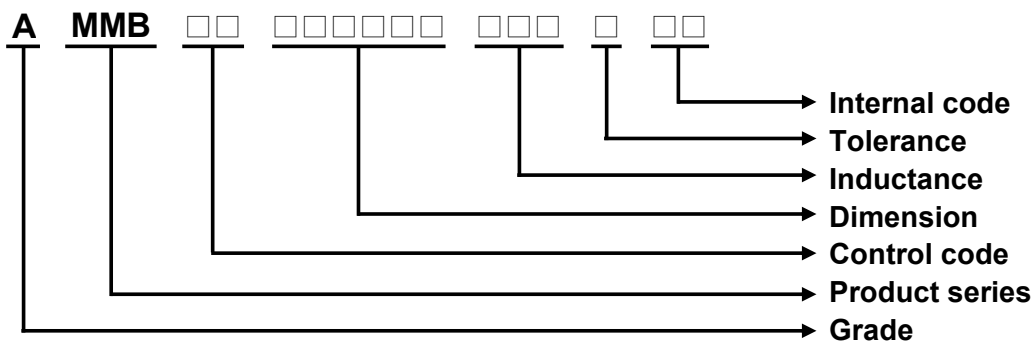

3 Temperature rating

Operating Temperature: -55°C~155°C

Storage Temperature: (on tape & reel): -20°C to +40°C; 75% RH max.

4 Marking

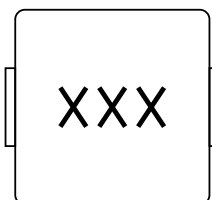

Marking : 1R0

5 Standard testing condition

	Unless otherwise specified	In case of doubt
Temperature	Ordinary Temperature(15 to 35°C)	20 to 30°C
Humidity	Ordinary Humidity(25 to 85% RH)	50 to 80 %RH

6 Configuration and dimensions

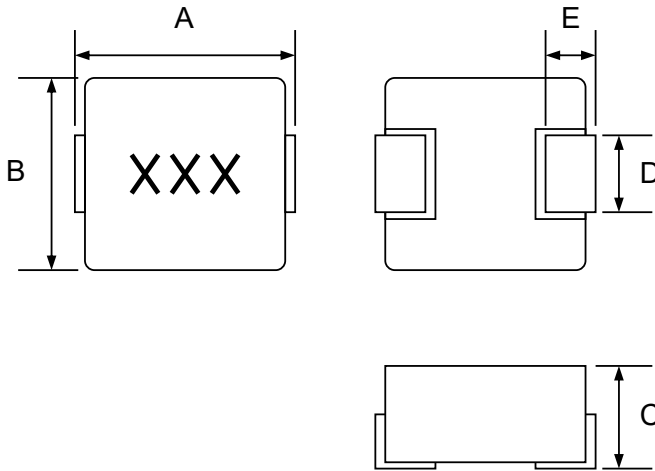

Dimensions in mm

Type	101040
A	11.5 Max
B	10 ± 0.3
C	4.0 Max
D	3.0 ± 0.5
E	2.0 ± 0.5

Size Code	Net weight(grams)
101040	2.4 (typ.)

7 Electrical characteristics

Part number	Inductance (μH)	Tolerance (±%)	Test Freq.	I _{rms} (A) Typ.	I _{sat} (A) Typ.	RDC (mΩ) Max.(Typ.)	Marking
AMMB001010401R0MS1	1	20	100kHz,0.5V	21	30	2.9(2.7)	1R0

Note:

1. Operating temperature range -55°C to 155°C.
2. I_{sat} for Inductance drop 20% from its value without current.
3. I_{rms} for a 40°C temperature rise from 25°C ambient.
4. The part temperature (ambient + temp rise) should not exceed 155°C under worst case operating conditions. Circuit design 155°C under worst case operating conditions. Component placement, PCB trace size and thickness, airflow and other cooling provisions all affect the part temperature. Part temperature should be verified in the end application.
5. Absolute maximum voltage 25V DC. (Based on test method, it may not the same under different application, it is recommended to verify first.)

8 | **AMMB00101040 Series**

8.1 Construction

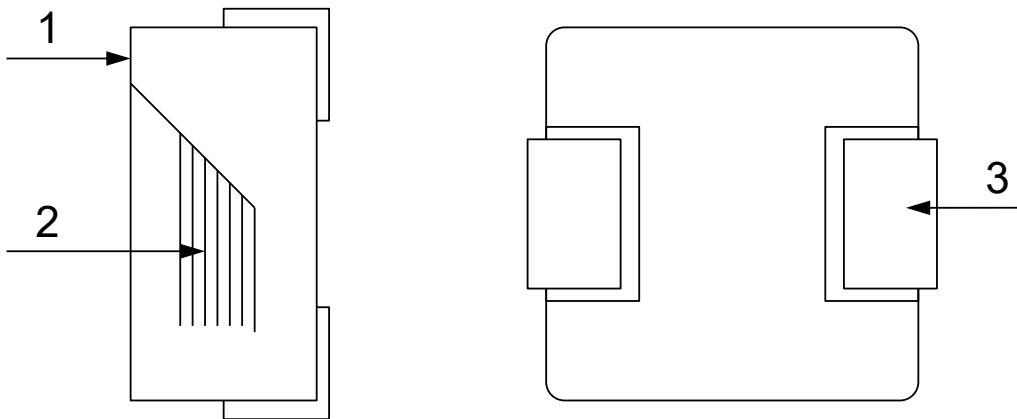

8.2 Material List

Item	Part	Description
1	Magnetic core	Magnetic metal powder
2	Coil	Enameled copper wire
3	Terminals	Copper based terminal

9 Reliability test items

1-1.Mechanical Performance

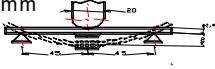
No	Item	Specification	Test Method
1-1-1	Board Flex	The forces applied on the right conditions must not damage the terminal electrode and the ferrite	Refer to AEC-Q200-005 Test device shall be soldered on the substrate Substrate Dimension: 100x40x1.6mm Deflection: 2.0mm Keeping Time: 60sec 
1-1-2	Resistance to Soldering Heat	Appearance: No damage Inductance change shall be within $\pm 10\%$.	Refer to MIL-STD-202 Method 210 Solder Composition: Sn/Ag3.0/Cu0.5(Pb-Free) Solder Temperature: $260 \pm 5^\circ\text{C}$ Immersion Time: 10 ± 1 sec
1-1-3	Solder ability	The electrodes shall be at least 95% covered with new solder coating	Refer to J-STD-002 Pre-heating: 150°C , 1min Solder Composition: Sn/Ag3.0/Cu0.5(Pb-Free) Solder Temperature: $245 \pm 5^\circ\text{C}$ (Pb-Free) Immersion Time: 4 ± 1 sec
1-1-4	Terminal Strength Test	Appearance: No damage	Refer AEC-Q200-006 Soldered on PCB for testing as fig. Force : 1.8kg Keeping Time: 60 seconds.
1-1-5	Resistance to Solvent	There must be no change in appearance or obliteration of marking	Refer to MIL-STD-202 Method 215 Inductors must withstand 6 minutes of alcohol or water. Sample Size : 15 pcs
1-1-6	Vibration	Appearance: No damage Inductance change shall be within $\pm 10\%$.	Refer MIL-STD-202 Method 204 Vibration waveform: Sine waveform Vibration frequency: 10Hz~2000Hz Vibration acceleration: 5g Sweep rate: 0.764386octave/minute Duration of test: 12 cycles each of 3 orientations, 20 minutes for each cycle Vibration axes: X, Y & Z

1-2.Environmental Performance

No	Item	Specification	Test Method
1-2-1	Temperature Cycle	Appearance: No damage Inductance change shall be within $\pm 20\%$	Refer to JESD Method JA-104 Total cycles: 1000 cycles Temperature Cycling Test Conditions : -55 to 155°C -55°C Soak Mode Condition : 30 minutes 155°C Soak Mode Condition : 30 minutes Measured after exposure in the room condition for 24hrs
1-2-2	Biased Humidity Resistance		Refer to MIL-STD-202 Method 103 Temperature: $85 \pm 2^\circ\text{C}$ Relative Humidity: 85% / Time: 1000hrs Measured after exposure in the room condition for 24hrs
1-2-3	High Temperature Exposure (Storage)		Refer to MIL-STD-202 Method 108 Temperature: $155 \pm 3^\circ\text{C}$ Time: 1000hrs Measured after exposure in the room condition for 24hrs
1-2-4	Operational Life		Refer to MIL-PRF-27 Temperature : 155°C (including heat rise) Applied Current : Rated Current Time: 1000hrs Measured after exposure in the room condition for 24hrs

10 Recommended IR reflow profile

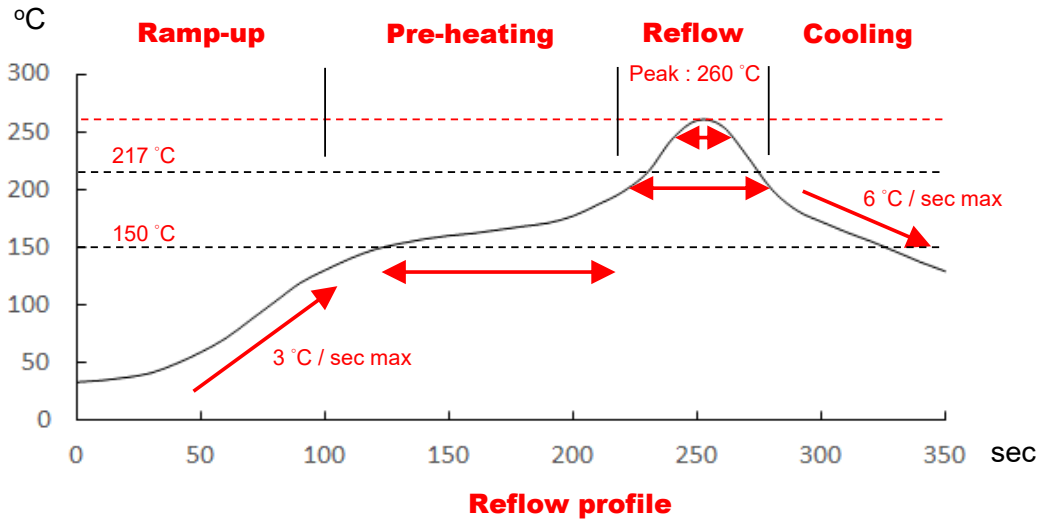

Lead-Free(LF)

Refer to J-STD-020F

Item	Ramp-up	Pre-heating	Reflow	Peak Temp.	Cooling
Temp. scope	R.T. ~150 °C	150 °C~200 °C	217 °C	260±5 °C	Peak Temp. 150 °C
Time spec	-	60~120 sec	60~150 sec	20~40 sec	-

Note:

1. IR reflow times: within 3 times
2. Nitrogen adopted is recommended while in IR reflow

11 Packaging

11.1 Packaging-cover tape

The force for tearing off cover tape is 10 to 130 grams.

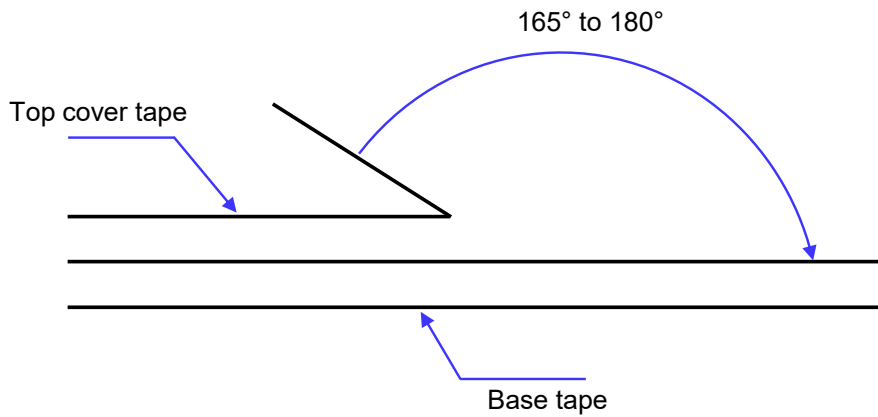

11.2 Packaging quantity

Type	pcs/reel
101040	500

11.3 Reel dimensions

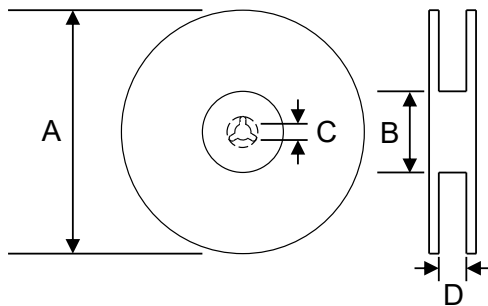

Dimensions in mm

Type	A	B	C	D
101040	330	100	13	24.2

11 Packaging

11.4 Tape dimensions in mm

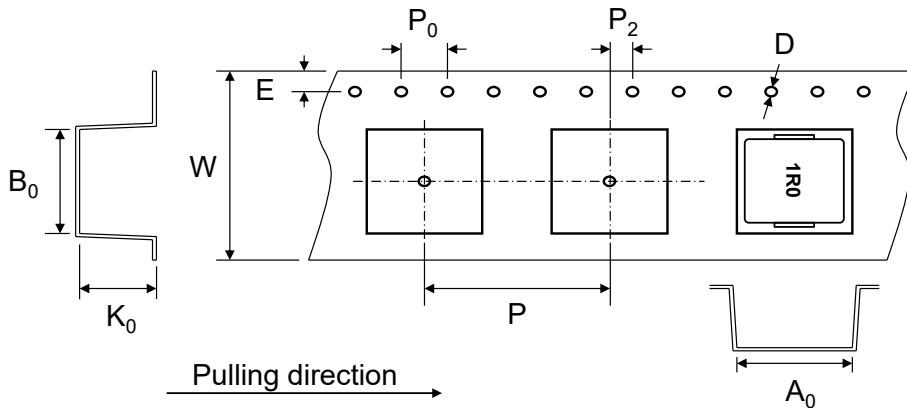

Type	A ₀	B ₀	K ₀	D	E	W	P	P ₀	P ₂
101040	10.4	11.5	4.5	1.5	1.75	24	16	4	2

12 Recommended pattern

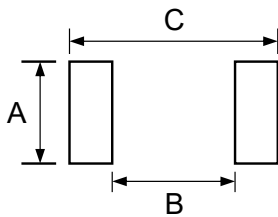

Dimensions in mm

Type	A	B	C
101040	4.0	6.0	13.0

13 Note

1. Please make sure that your product has been evaluated and confirmed against your specifications when our product is mounted to your product.
2. Don't design/mount any components in contact with this product.
3. The moisture sensitivity level (MSL) of products is classified as level 1.
4. Shelf life: 1 years from the date of shipment.

14 Graph

