

6 Electrical Characteristics:

PT/NO.	Impedance(Ω) at 100MHz		Resistance RDC(Ω) Max.(1 line)	Rated Current (A) Max.	Insulation Resistance (M Ω) Min.	Rated Voltage (V)Max.
	Min.	Typ.				
APPM00070638400XY0	40	70	5m	15	10	125
APPM00070638101XY0	100	140	10m	9.0	10	125
APPM00070638301XY0	225	300	10m	5.0	10	125
APPM00070638501XY0	275	350	10m	5.0	10	125
APPM00070638701XY0	500	700	15m	4.0	10	125
APPM00070638102XY0	800	1020	17m	3.0	10	125
APPM00070638132XY0	910	1300	21m	2.5	10	125
APPM00070638272XY0	2000	2700	63m	1.0	10	125
APPM00070638302XY0	2500	3000	75m	0.9	10	125

CIRCUIT DIAGRAM

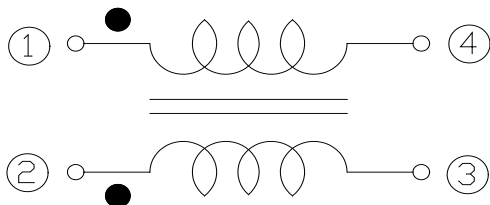

NOTE:

1. Rated DC Current : Based on temperature rise (ΔT : 40°C Typ.)
2. Hi-Pot(Pri-Sec) : 800V DC/ 1mA/ 3 seconds

6 Electrical Characteristics:

(6)-1 Impedance

Measured by HP4291B RF Impedance Analyzer.

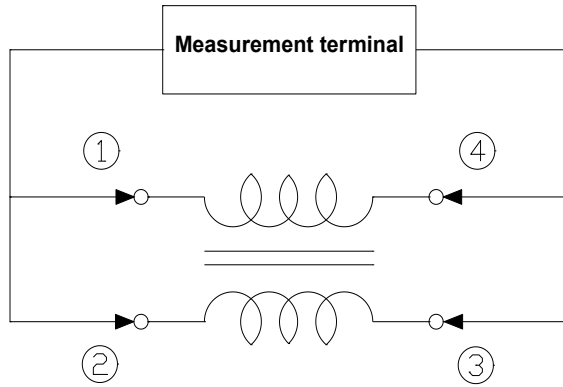

(6)-2 DC Resistance

Measured by Chroma 16502 milliohm meter.

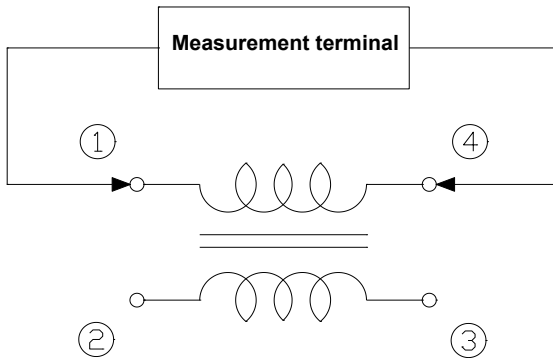

(6)-3 Insulation Resistance

Measured by Chroma 19073

Measurement voltage : 125V , Measurement time : 3 sec.

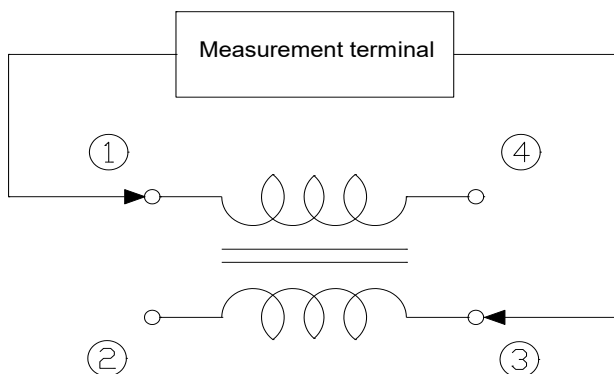

6 | 6.1 Construction:

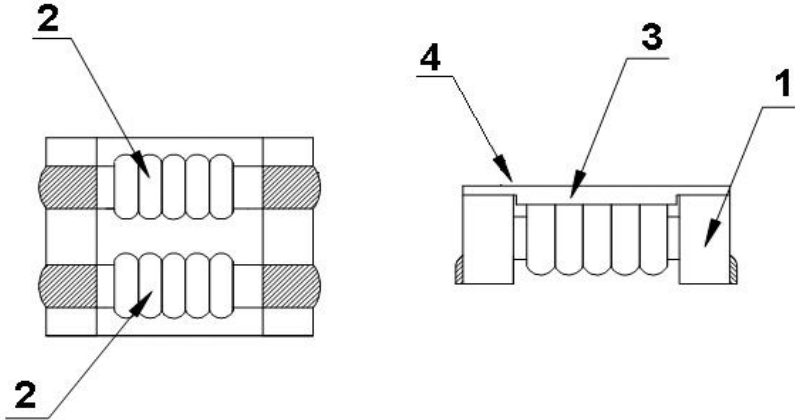

6.2 Material List:

NO.	ITEM	DESCRIPTION & TYPE
1	CORE	FERRITE
2	Wire	Magnet Wire
3	Cover	LCP
4	Marking	INK

Mechanical

TEST ITEM	SPECIFICATIONS	TEST CONDITIONS
Solderability	No more than 5% of the solderable metalization exposed underlying, non-wettable base metal or metallization layers or portions of the ceramic substrate after exposure to molten solder.	Refer to J-STD-002 For both Leaded & SMD. Electrical Test not required. Test Method B @ 245±5°C, dwell for 5+0/-0.5 seconds
Resistance to Soldering heat (reflow soldering)	There shall be no damage or problems.	<p>Temperature profile of reflow soldering</p> <p>Note: 1. Re-Flow Possible times: within 3 times 2. Nitrogen adopted is recommended while in re-flow</p>
Terminal strength	The terminal electrode and the ferrite must not be damaged.	With the component mounted on a PCB obtained from the Supplier with the device to be tested, apply a 17.7 N (1.8 Kg) force to the side of a device being tested. This force shall be applied for 60 +1 seconds. Also the force shall be applied gradually as not to apply a shock to the component being tested.
Strength on PC board bending	The terminal electrode and the ferrite must not be damaged.	<p>Test device shall be soldered on the substrate</p> <p>Substrate Dimension: 100x40x1.6mm</p> <p>Deflection: 2.0mm</p> <p>Keeping Time: 60 sec</p>
High Temperature Exposure (Storage)	<p>Impedance: Within ±20% of the initial value.</p> <p>Insulation resistance and DC resistance on the specification shall be met.</p> <p>The terminal electrode and the ferrite must not be damaged.</p>	1000hrs. at rated operating temperature, part can be stored for 1000 hrs. @ 150°C. Unpowered. Measurement at 24±4 hours after test conclusion.

Environment Characteristics

TEST ITEM	SPECIFICATIONS	TEST CONDITIONS
Humidity Bias	<p>Impedance: Within $\pm 20\%$ of the initial value.</p> <p>Insulation resistance and DC resistance on the specification shall be met.</p> <p>The terminal electrode and the ferrite must not be damaged.</p>	<p>Precondition: Reflow peak temperature 260°C 3 times. (Reference: J-STD-020)</p> <p>1000 hours 85°C/85%RH. Unpowered. Measurement at 24\pm4 hours after test conclusion.</p>
Vibration	<p>Impedance: Within $\pm 20\%$ of the initial value.</p> <p>Insulation resistance and DC resistance on the specification, shall be met.</p> <p>The terminal electrode and the ferrite must not be damaged.</p>	<p>MIL-STD-202 Method 204</p> <p>5 g's for 20 minutes, 12 cycles each of 3 orientations.</p> <p>Test from 10-2000Hz.</p>
Temperature Cycling	<p>Impedance: Within $\pm 20\%$ of the initial value.</p> <p>Insulation resistance and DC resistance on the specification, shall be met.</p> <p>The terminal electrode and the ferrite must not be damaged.</p>	<p>Precondition: Reflow peak temperature 260°C 3 times. (Reference: J-STD-020)</p> <p>1000 cycles (-55°C to +150°C). Measurement at 24\pm4 hours after test conclusion. 30min maximum dwell time at each temperature extreme. 1 min. maximum transition time.</p>
High Temperature Operating Life	<p>Impedance: Within $\pm 20\%$ of the initial value.</p> <p>Insulation resistance and DC resistance on the specification, shall be met.</p> <p>The terminal electrode and the ferrite must not be damaged.</p>	<p>Precondition: Reflow peak temperature 260°C 3 times. (Reference: J-STD-020)</p> <p>1000 hrs. @ 125 °C, apply maximum rated power. Measurement 24\pm4 hours after test conclusion.</p>
Physical Dimensions	<p>Verify physical dimensions to the applicable component detail specification.</p>	<p>Any applicable method using x10 magnification, micrometers, calipers, gauges, contour projectors, or other measuring equipment, capable of determining the actual specimen dimensions.</p>
Mechanical Shock	<p>1. Electrical characterization- Impedance: Within $\pm 20\%$ change range</p> <p>2. Appearance- No damage (OM)</p>	<p>Units are non-operating.</p> <p>Pulse shape : Half-sine waveform</p> <p>Impact acceleration : 100 g's</p> <p>Pulse duration : 6 ms</p> <p>Number of shocks : 18 shocks (3 shocks for each face)</p>
Flammability	<p>The marking and A side have no obvious broken, and the marking are clearly</p>	<p>Refer to UL 94</p> <p>Burning stops within 10 seconds on a vertical specimen; drips of particles allowed as long as they are not inflamed.</p>

7 Packaging:

7.1 Packaging -Cover Tape

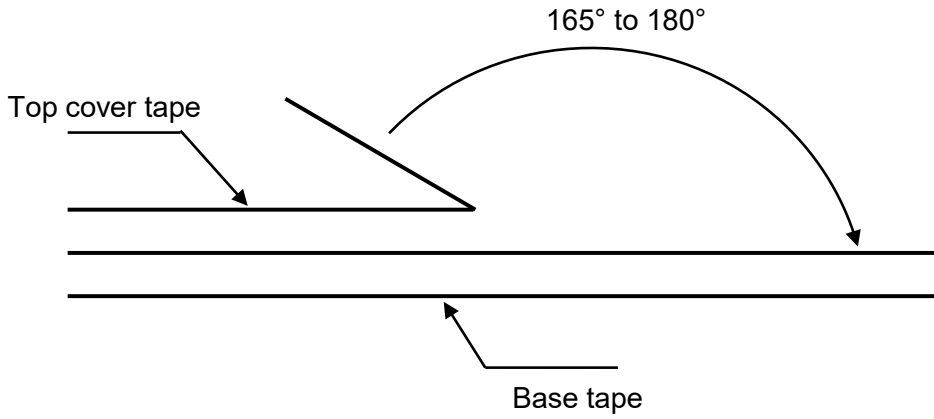

7.2 Packaging Quantity

TYPE	PCS/REEL
APPM00070638	1500

7.3 Reel Dimensions

Unit : mm

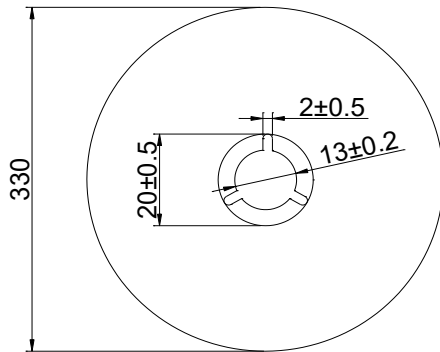

7 Packaging:

7.4 Tape Dimensions in mm

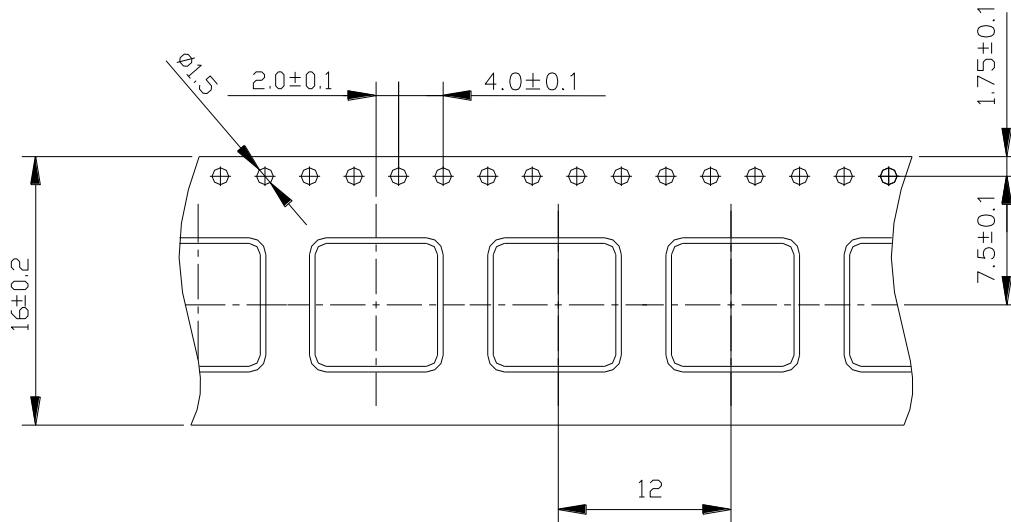

Unreeling Direction

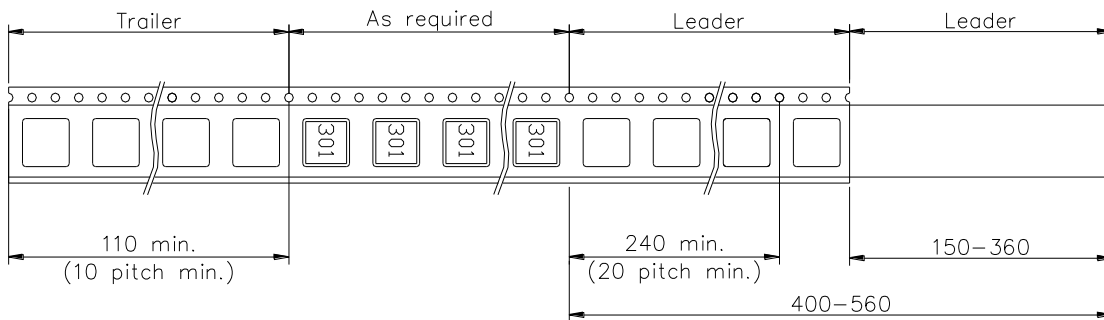
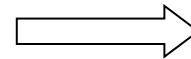

8 Recommended Land Pattern:

(STANDARD PATTERN) Unit : mm

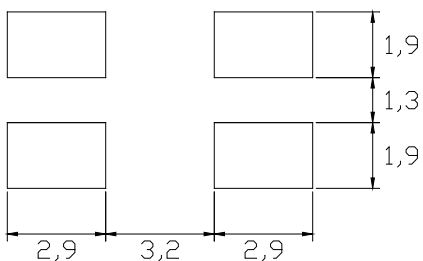

9 Note:

1. Please make sure that your product has been evaluated and confirmed against your specifications when our product is mounted to your product.
2. Do not knock or drop.
3. All the items and parameters in this product specification have been prescribed on the premise that our product is used for the purpose, under the condition and in the environment agreed upon between you and us. You are requested not to use our product deviating from such agreement.
4. Please keep the distance between transformer/coil and other components (refer to the standard IEC 950)
5. The moisture sensitivity level (MSL) of products is classified as level 1.
6. Suggestion
On customer side this product series need to be fixed by the glue after IR reflow.

Please refer to below example photo:

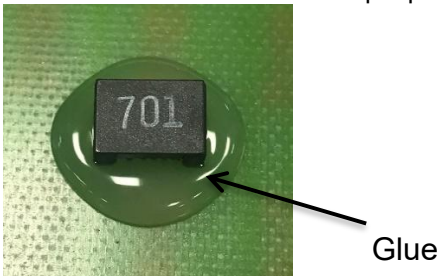

Typical Electrical Characteristics

Frequency vs impedance

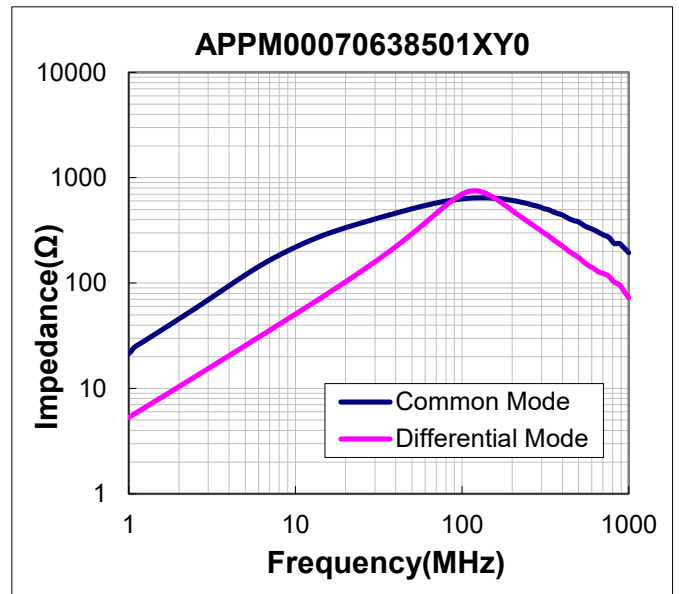
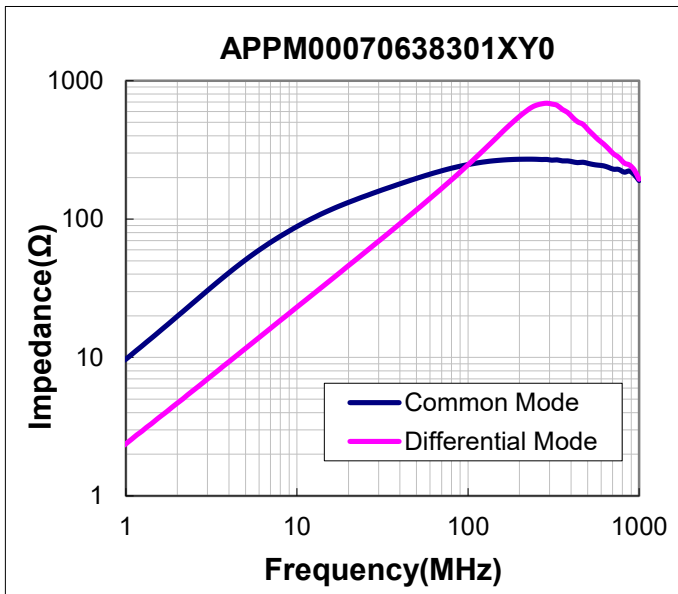
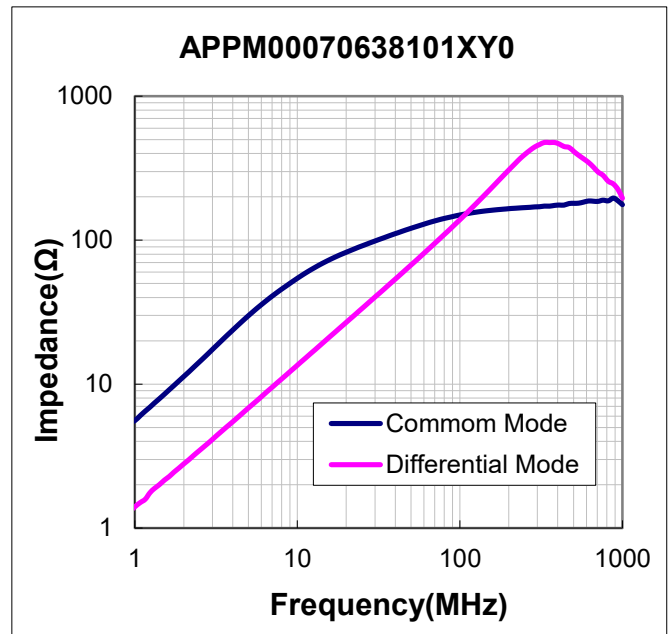
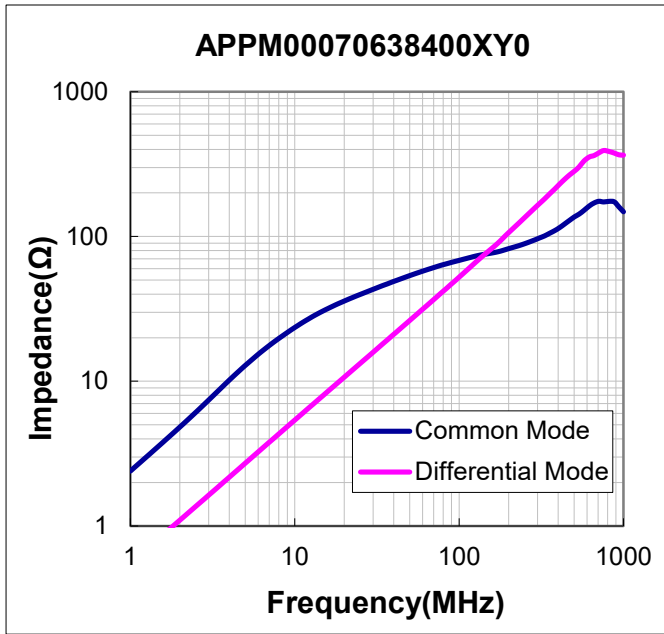

Typical Electrical Characteristics

Frequency vs impedance

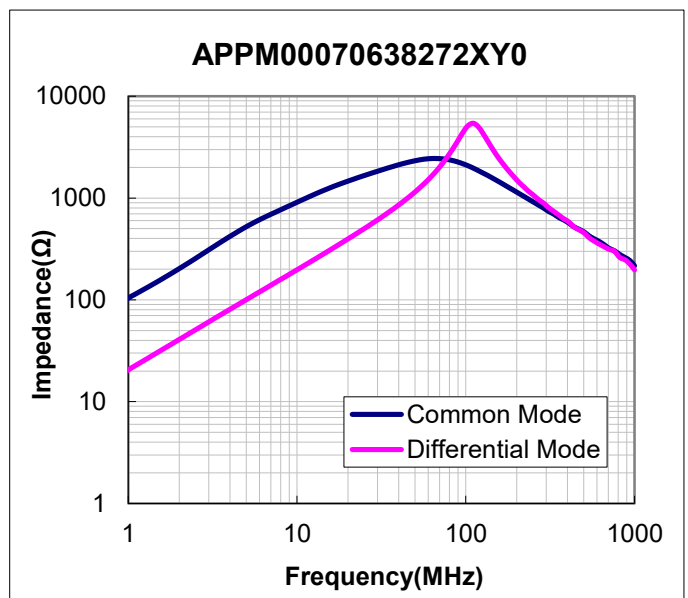
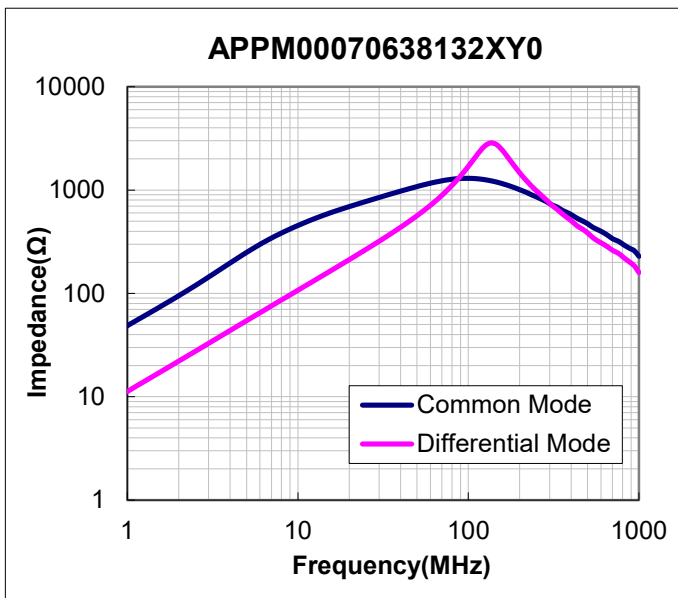
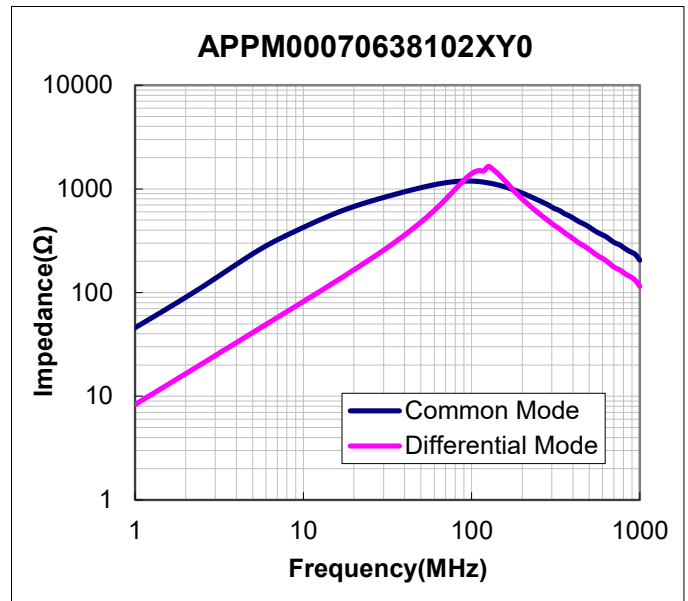
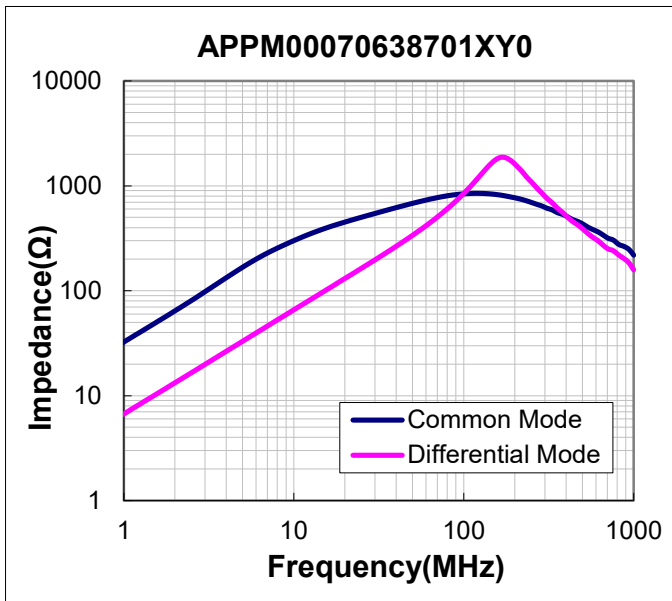

Typical Electrical Characteristics

Frequency vs impedance

