

Issue date  
Jan. 09. 2025

NICHICON CORPORATION

NICHICON (IWATE) CORPORATION  
ENGINEERING DEPT.

# S P E C I F I C A T I O N

## O F

### CONDUCTIVE POLYMER HYBRID ALUMINUM ELECTROLYTIC CAPACITORS

GYC series (Pb free)

DWG. No.	G240617U3-A	DESIGNED.	<i>Y. Tamura</i>	Jan. 09. 2025
		CHECKED	<i>K. matsushima</i>	Jan. 09. 2025
		APPROVED	<i>K. Yamamoto</i>	Jan. 09. 2025

# nichicon

## REVISION

MARK	DATE	REVISION	APPROVED
A	2025. 1. 9	Add REVISION sheet. Sheet2 Change Voltage. Sheet2, 6, 7, 10, 11 Add Voltage 80V. Sheet10 Add $\phi 10 \times 12.5L$ . Sheet10 Add ESR. Sheet11 Add Ripple current. Sheet20 Change a material of plastic platform.	YAMAMOTO

## 1. SCOPE

This specification covers "GYC series" conductive polymer hybrid aluminum electrolytic capacitors. (JIS-32 TYPE)

## 2. APPLICABLE STANDARD

Japanese Industrial Standard JIS C5101-4 Characteristics W and JIS C5101-1 except as specified in this specification.

## 3. OPERATING TEMPERATURE RANGE

Operating temperature range is the range of ambient temperature at which the capacitor can be operated continuously at rated voltage.  
-55 to +135degC

## 4. PERFORMANCE

Unless otherwise specified, the standard range of atmospheric conditions for making measurements and tests are as follows :

Ambient temperature : 5 to 35degC  
Relative humidity : 45 to 85%  
Air pressure : 86kPa to 106kPa

If there may be doubt on the results, measurements shall be made within the following limits,

Ambient temperature :  $20 \pm 2$ degC  
Relative humidity : 60 to 70%  
Air pressure : 86kPa to 106kPa

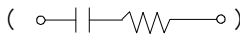
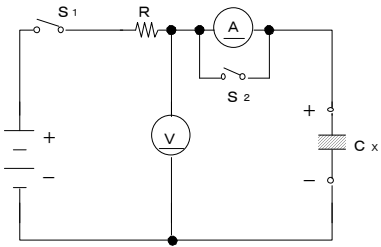
4.1 ELECTRICAL CHARACTERISTICS																				
No.	Item	Test method			Performance															
A	4.1.1 RATED VOLTAGE				DC 16~ <del>63</del> V 80															
	4.1.2 RATED CAPACITANCE	Measuring frequency 120Hz $\pm 20\%$ Measuring circuit : Series equivalent circuit (  ) Measuring voltage : 0.5Vrms or less +1.5 to 2.0 VDC			10~560 $\mu$ F  Capacitance tolerance: $\pm 20\%$															
	4.1.3 $\tan \delta$	Measuring frequency, measuring circuit and measuring voltage are the same those for capacitance.			Not more than the value given in table 1.															
A	4.1.4 LEAKAGE CURRENT	The rated voltage shall be applied across the capacitor and its protective resistor which shall be $1000 \pm 100 \Omega$ . The leakage current shall then be measured after an electrification period of 2 min.  Measurement circuit    R : Protective resistor ( $1000 \pm 100 \Omega$ ) (A) : DC ammeter (V) : DC voltmeter S <sub>1</sub> : switch S <sub>2</sub> : Protective switch for an ammeter C <sub>x</sub> : Test Capacitor			After 2 min; not more than 16 to 63V : $I = 0.01CV (\mu A)$ 80V : $I = 0.05CV (\mu A)$  I : Leakage current ( $\mu A$ ) C : Capacitance ( $\mu F$ ) V : Rated voltage (V)  Leakage current changes depending on the preprocessings and use condition. Therefore, do the voltage treatment when there is a doubt. (See sheet 19)															
	4.1.5 ESR	at 100kHz $\pm 20\%$ 20°C $\pm 2^\circ C$			Not more than the value given in sheet 10 (9. ESR)															
	4.1.6 TEMPERATURE CHARACTERISTIC	<table border="1" style="width: 100%; border-collapse: collapse;"> <thead> <tr> <th style="width: 5%;">Step</th> <th style="width: 45%;">Temperature</th> <th style="width: 50%;">Time</th> </tr> </thead> <tbody> <tr> <td style="text-align: center;">1</td> <td style="text-align: center;"><math>20 \pm 2 \text{ degC}</math></td> <td style="text-align: center;">-----</td> </tr> <tr> <td style="text-align: center;">2</td> <td style="text-align: center;"><math>-25, -55 \text{ } ^\circ \text{ degC}</math></td> <td style="text-align: center;">2h.</td> </tr> <tr> <td style="text-align: center;">3</td> <td style="text-align: center;"><math>20 \pm 2 \text{ degC}</math></td> <td style="text-align: center;">15min.</td> </tr> <tr> <td style="text-align: center;">4</td> <td style="text-align: center;"><math>135 \text{ } ^\circ \text{ degC}</math></td> <td style="text-align: center;">2h.</td> </tr> </tbody> </table>	Step	Temperature	Time	1	$20 \pm 2 \text{ degC}$	-----	2	$-25, -55 \text{ } ^\circ \text{ degC}$	2h.	3	$20 \pm 2 \text{ degC}$	15min.	4	$135 \text{ } ^\circ \text{ degC}$	2h.	Step 1 : Capacitance and impedance shall be measured. ( $ Z $ 20degC 100kHz $\pm 20\%$ )  Step 2 : After the capacitor being stored for 2 hours, Impedance shall be made at thermal stability. ( $ Z $ -25, -55degC 100kHz $\pm 20\%$ )  Step 4 : After the capacitor being stored for 2 hours, capacitance shall be measured. The measurement shall be made at thermal stability.		Step 2 : Impedance ratio : Ratio to the value at step 1 shall be not more than the value given Table-1.  Step 4 : Capacitance change : Within $\pm 30\%$ of the initial capacitance value against Step.1
Step	Temperature	Time																		
1	$20 \pm 2 \text{ degC}$	-----																		
2	$-25, -55 \text{ } ^\circ \text{ degC}$	2h.																		
3	$20 \pm 2 \text{ degC}$	15min.																		
4	$135 \text{ } ^\circ \text{ degC}$	2h.																		

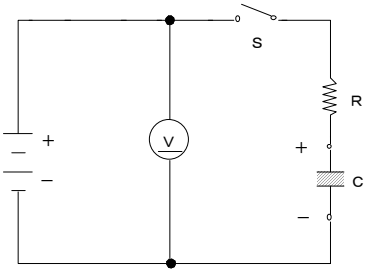
No.	Item	Test method	Performance
4.1.7	SURGE TEST	<p>Voltage application :            1000 times of charging for <math>30 \pm 5</math> sec.,            with a period of <math>6 \pm 0.5</math> min..            Test temperature : 15 to 35degC            And the capacitor shall be stored under            standard atmospheric conditions to            obtain thermal stability, after which            measurements shall be made.</p> <p>Test circuit</p> <div style="display: flex; align-items: center; justify-content: center;">  <div style="margin-left: 20px;"> <p>R : Protective series resistor (1000Ω)</p> <p>V : DC voltmeter</p> <p>S : Switch</p> <p>C<sub>x</sub> : Test capacitor</p> </div> </div> <p>Note : This requirement is applicable only to instantaneous overvoltage which may be applied to the terminals of capacitor, therefore, not applicable to such overvoltages as often applied.</p>	<p>Capacitance            Not less than 80% of            the value before test.</p> <p>tan δ :            200% or less the            initial specified value.</p> <p>Leakage current :            Initial specified value            or less.</p>

## 4.2 MECHANICAL PERFORMANCE

No.	Item	Test method	Performance
4.2.1	RESISTANCE TO VIBRATION	<p>○Standard</p> <p>As per JIS C 5101-1 4.17</p> <p>Direction and duration of vibration:            3 orthogonal directions mutually each            for 2h. Total 6h.</p>	<p>When the capacitance is            measured, there shall be            no intermittent contacts,            or open or short-            circuiting.            There shall be no such            mechanical damage.            Appearance :            No remarkable            abnormality.</p>
		<p>○Vibration resistance</p> <p>Acceleration : <math>294 \text{ m/s}^2</math> ( 30G )            Frequency : 10 to 2000 Hz            Amplitude : 1.5mm max ( peak to peak )            Direction and duration of vibration :            It is done in the X, Y, Z axis            direction for 2 hours each,            with a total of 6 hours.</p>	<p>When the capacitance is            measured, there shall be            no intermittent contacts,            or open or short-            circuiting.            There shall be no such            mechanical damage.            Appearance :            No remarkable            abnormality.</p>
4.2.2	SOLDERABILITY	<p>As per JIS C 5101-1 4.15</p> <p>Temperature of solder : <math>235 \pm 5</math>degC            Dipping time : <math>2 \pm 0.5</math> s            Storage time : after 6 month</p>	<p>At least 3/4 of            circumferential surface            of the dipped protion of            termination shall be            covered with new solder.</p>

**4.3 ENDURANCE PERFORMANCE**

No.	Item	Test method	Performance
4.3.1	RESISTANCE OF REFLOW	The reflow is done under reflow condition on sheet 16. After the capacitors are restored to standard atmospheric conditions for 1 to 2 hours, the capacitors shall meet the right requirements.	Capacitance change : Within $\pm 10\%$ of the initial capacitance value. $\tan \delta$ : Initial specified value or less. ESR : 130% or less of initial specified value. Leakage current : Initial specified value or less. ( Voltage treatment (See sheet 19) ) Appearance : No remarkable abnormality.
4.3.2	RESISTANCE TO DAMP HEAT	Test temperature : $85 \pm 2 \text{degC}$ Relative humidity : 85% Test time : $2000 \frac{+72}{-0} \text{ h}$ With rated voltage applied.  After restored to standard atmospheric conditions, the capacitors shall meet the right requirements.	Capacitance change : Within $\pm 30\%$ of the initial capacitance value. $\tan \delta$ : 200% or less the initial specified value. ESR : 200% or less the initial specified value. Leakage current : Initial specified value or less. Appearance : No remarkable abnormality.

No.	Item	Test method	Performance								
4.3.3	LIFE TEST	<p>As per JIS C 5101-1 4.23</p> <p>Test temperature : 135 ±2degC : 125 ±2degC</p> <p>Test time : ※1 h</p> <p>The D.C. bias plus rated ripple current is applied (See sheet 11) for ※1 hours at 135°C or 125°C the peak voltage shall not exceed the rated voltage.</p> <p>※1</p> <table style="margin-left: 20px;"> <tr> <td>φ 6.3</td> <td>: 2000</td> <td><sup>+72</sup><sub>-0</sub></td> </tr> <tr> <td>φ 8、φ 10</td> <td>: 4000</td> <td><sup>+72</sup><sub>-0</sub></td> </tr> </table>	φ 6.3	: 2000	<sup>+72</sup> <sub>-0</sub>	φ 8、φ 10	: 4000	<sup>+72</sup> <sub>-0</sub>	<p>Capacitance change : Within ±30% of the initial capacitance value.</p> <p>tan δ : 200% or less the initial specified value.</p> <p>ESR : 200% or less the initial specified value.</p> <p>Leakage current : Initial specified value or less.</p> <p>Appearance : No remarkable abnormality.</p>		
φ 6.3	: 2000	<sup>+72</sup> <sub>-0</sub>									
φ 8、φ 10	: 4000	<sup>+72</sup> <sub>-0</sub>									
4.3.4	SHELF LIFE TEST	<p>Test temperature : 135 ±2degC</p> <p>Test time : 1000 <sup>+48</sup><sub>-0</sub> h</p>	<p>Capacitance change : Within ±30% of the initial capacitance value.</p> <p>tan δ : 200% or less the initial specified value.</p> <p>ESR : 200% or less the initial specified value.</p> <p>Leakage current : Initial specified value or less.</p> <p>( Voltage treatment according to JIS C 5101-4 4.1 )</p> <p>Appearance : No remarkable abnormality.</p>								
4.3.5	PRESSURE RELIEF VENT TEST (In case φ10×16.5)	<p>A.C. Application Test</p> <p>The capacitor shall be subjected to an A.C. voltage(50 or 60Hz) with r.m.s.value equal to 0.7 times the rated D.C. voltage through a series resistor.</p> <p>The series resistor as follows.</p> <table border="1" style="margin-left: 40px; border-collapse: collapse;"> <thead> <tr> <th style="text-align: center;">Cap. (μF)</th> <th style="text-align: center;">R(Ω)</th> </tr> </thead> <tbody> <tr> <td style="text-align: center;">C ≤ 10</td> <td style="text-align: center;">100</td> </tr> <tr> <td style="text-align: center;">10 &lt; C ≤ 100</td> <td style="text-align: center;">10</td> </tr> <tr> <td style="text-align: center;">100 &lt; C ≤ 1000</td> <td style="text-align: center;">1</td> </tr> </tbody> </table> <p>D.C. Application Test</p> <p>The capacitor Shall be subjected to a reverse D.C. voltage equal to the rated D.C. voltage. The current flowing through the capacitor shall be limited to 1A.</p> <p>Note : The test is terminated if the vent device is not actuated when 30min. has elapsed from the start of the test conducted under the conditions.</p>	Cap. (μF)	R(Ω)	C ≤ 10	100	10 < C ≤ 100	10	100 < C ≤ 1000	1	<p>The vent device is actuated under the test conditions, thereby preventing terminals, metal pieces, etc. of the capacitor from scattering due to burst, the case from separating from the seal packing, or the capacitor from producing flame.</p>
Cap. (μF)	R(Ω)										
C ≤ 10	100										
10 < C ≤ 100	10										
100 < C ≤ 1000	1										
SPECIFICATION		DWG. No.	G240617U3-A	sheet	5						

Table - 1 Electrical Characteristics

Rated voltage (V)	Surge voltage (V)	tan δ	Impedance ratio at 100kHz	
			$\frac{ Z _{-25^{\circ}\text{C}}}{ Z _{+20^{\circ}\text{C}}}$	$\frac{ Z _{-55^{\circ}\text{C}}}{ Z _{+20^{\circ}\text{C}}}$
16	20	0.16	2	2.5
25	32	0.14	2	2.5
35	44	0.12	2	2.5
50	63	0.10	2	2.5
63	79	0.08	2	2.5
<sup>A</sup> 80	100	0.08	2	2.5

## 5. MARKING

5.1 The following items shall be marked indelibly on the capacitor.

- (1) Manufacture's Trade mark (\* Size φ8, φ10 Only)
- (2) Rated voltage code
- (3) Rated capacitance
- (4) Lot No.
- (5) Negative polarity
- (6) Series identification : GYC

[Example] (φ6.3)

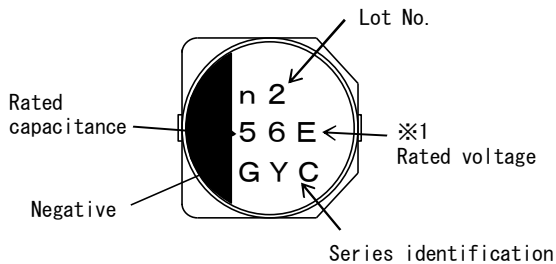

(φ8, φ10)

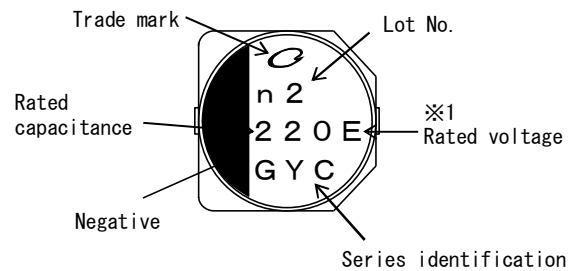

※1 (V) Rated voltage	16	25	35	50	63	<sup>A</sup> 80
Code	C	E	V	H	J	K

## 5.2 Marking color

Case : Laminated case  
Print : Black

## 5.3 Lot No.

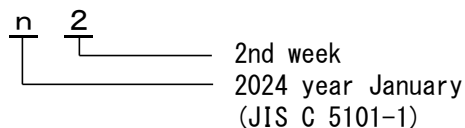

## 5.4 Production factory

JAPAN : NICHICON (IWATE) CORPORATION  
: NICHICON (OHNO) CORPORATION FUKUI FACTORY

## 6. TYPE NUMBERING SYSTEM

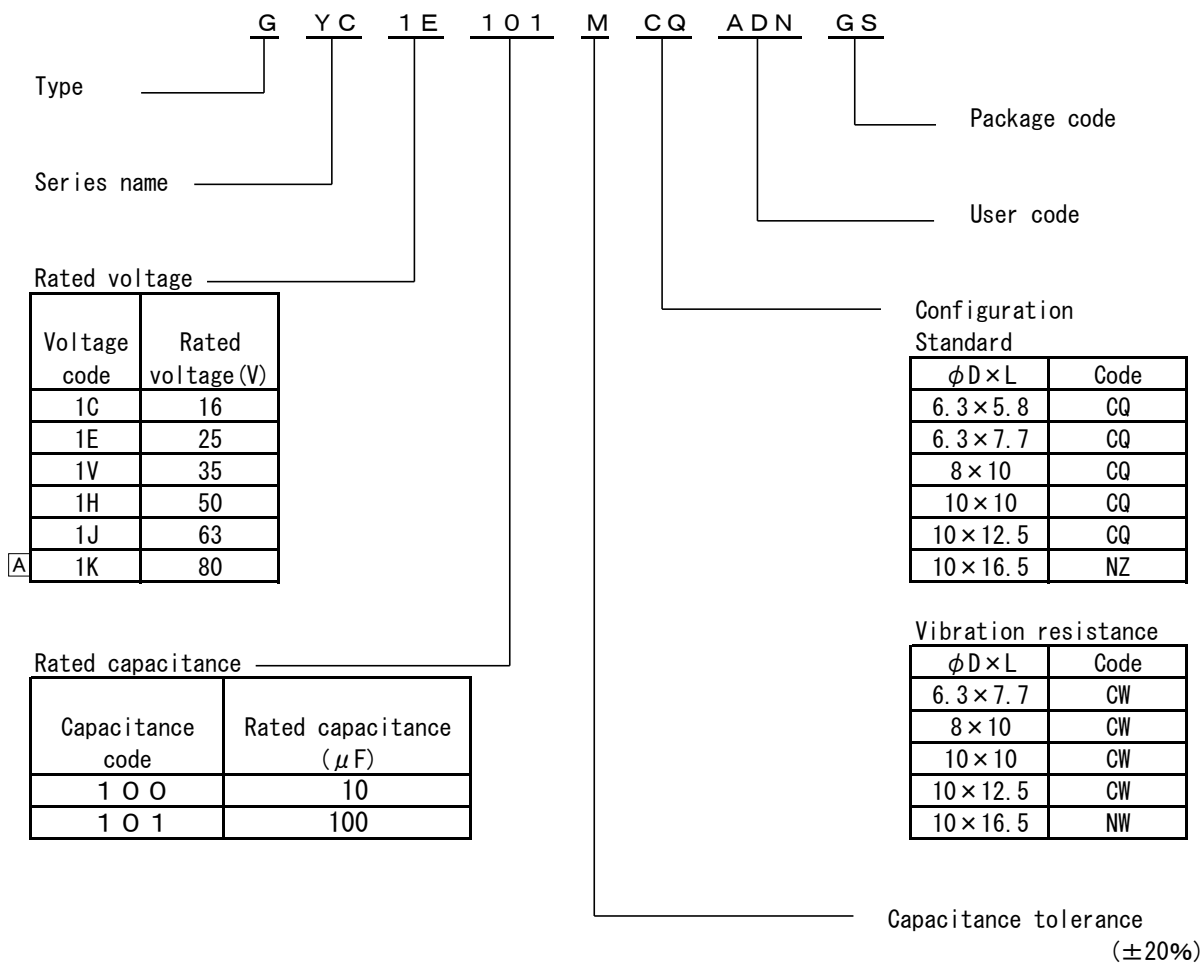

## 7. SHAPE AND DIMENSIONS

### 7.1 Standard

(1)  $\phi 6.3$

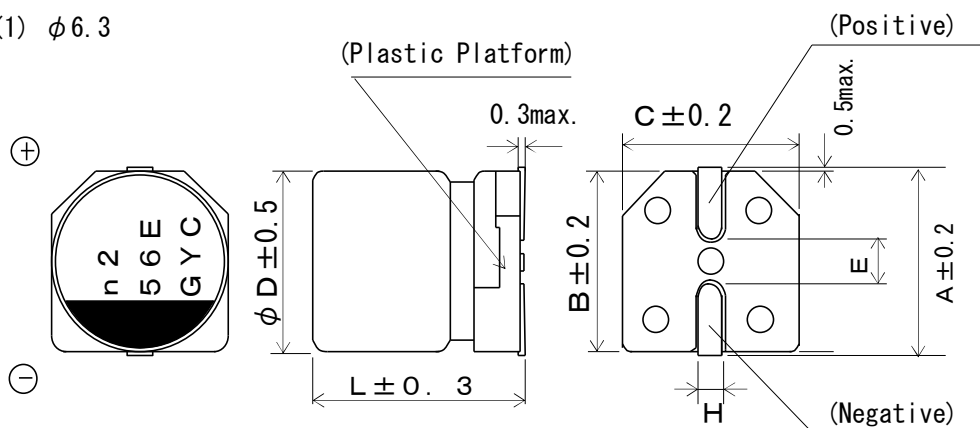

(2)  $\phi 8$ ,  $\phi 10 \times 10\text{L}$ ,  $\phi 10 \times 12.5\text{L}$

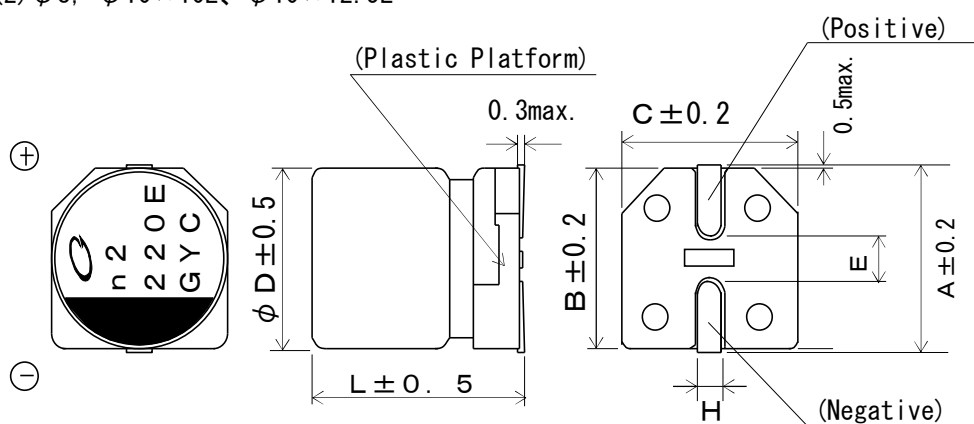

(3)  $\phi 10 \times 16.5\text{L}$

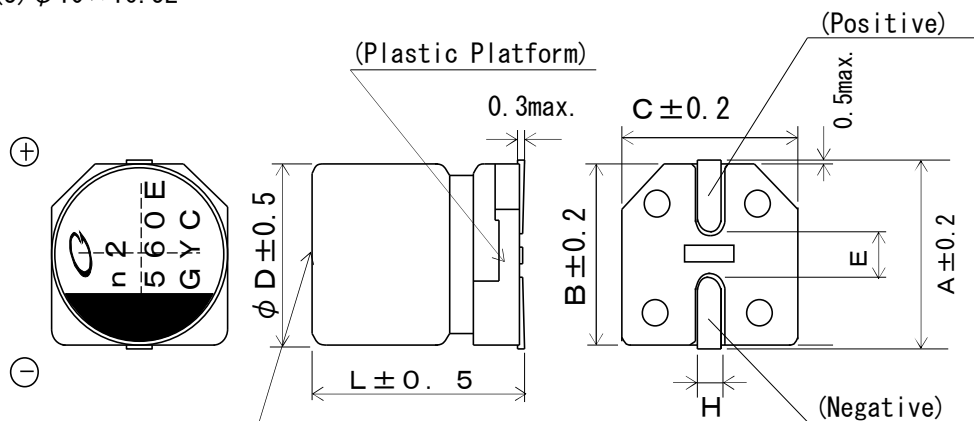

※ Pressure relief vent

※ Position of pressure relief vent is random to the terminal.

$\phi D \times L$	(mm)					
	6.3×5.8	6.3×7.7	8×10	10×10	10×12.5	10×16.5
A	7.3	7.3	9.0	11.0	11.0	11.0
B	6.6	6.6	8.3	10.3	10.3	10.3
C	6.6	6.6	8.3	10.3	10.3	10.3
E	2.2	2.2	3.1	4.5	4.5	4.5
L	5.8	7.7	10.3	10.3	12.5	16.5
H	0.5~0.8	0.5~0.8	0.8~1.1	0.8~1.1	0.8~1.1	1.1~1.5

## 7.2 Vibration resistance

(1)  $\phi 6.3 \times 7.7L$

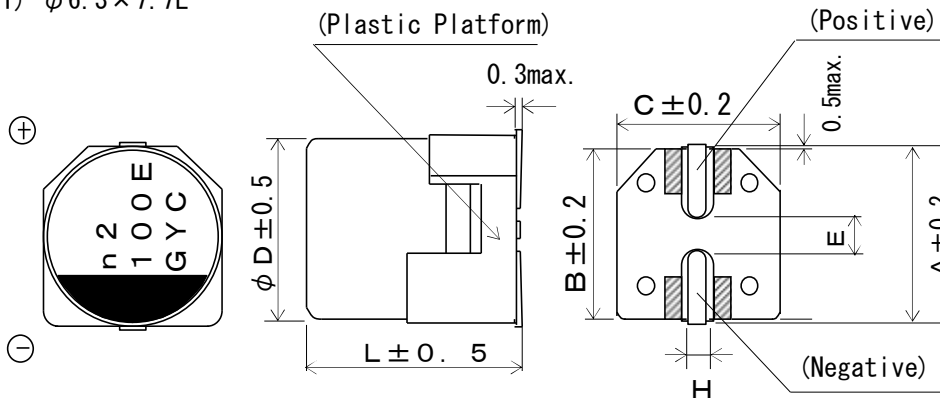

(2)  $\phi 8, \phi 10 \times 10L, \phi 10 \times 12.5L$

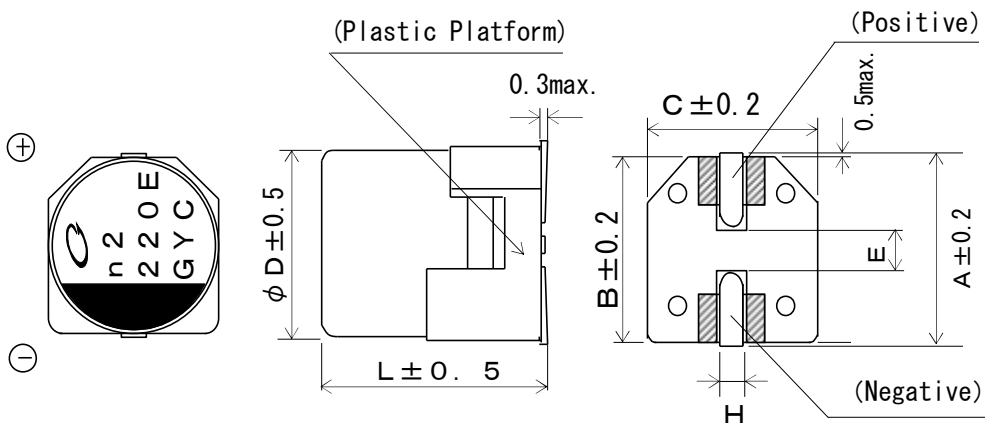

(3)  $\phi 10 \times 16.5L$

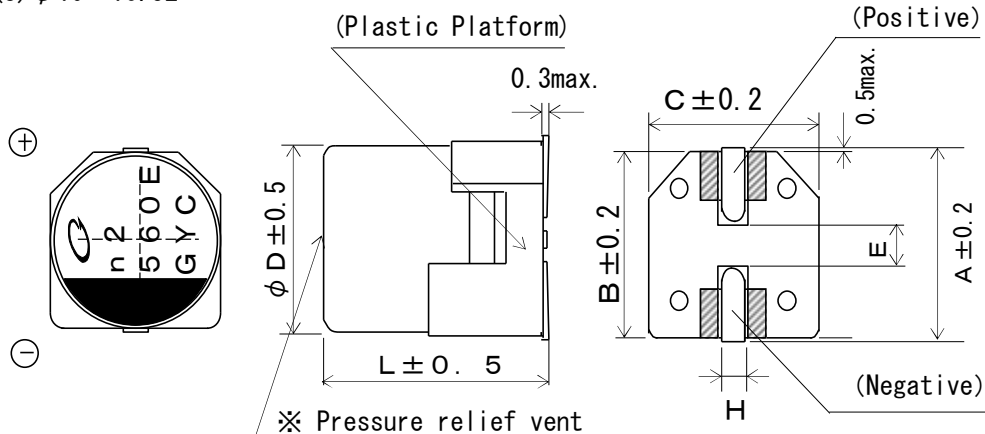

※ Position of pressure relief vent is random to the terminal.

▨ : Supportive Terminals  
Material : Sn (100%) Plating brass

$\phi D \times L$	6.3 × 7.7	8 × 10	10 × 10	10 × 12.5	10 × 16.5
A	7.3	9.0	11.0	11.0	11.0
B	6.6	8.3	10.3	10.3	10.3
C	6.6	8.3	10.3	10.3	10.3
E	2.2	3.1	4.5	4.5	4.5
L	7.7	10.5	10.5	12.8	16.8
H	0.5 ~ 0.8	1.1 ~ 1.5	1.1 ~ 1.5	1.1 ~ 1.5	1.1 ~ 1.5

## 8. Standard products Table

cap. \ vv	$\phi D \times L$ (mm)					
	16	25	35	50	63	<sup>A</sup> 80
10					6.3×5.8	
22				6.3×5.8	6.3×7.7	8×10
33			6.3×5.8	6.3×7.7	8×10	10×10
47		6.3×5.8	6.3×5.8	8×10	8×10	10×10
56		6.3×5.8			10×10	10×12.5
68		6.3×7.7	6.3×7.7	8×10	10×10	
82	6.3×5.8				10×10	
100		6.3×7.7	8×10	10×10	10×12.5	
120				10×10		
150	6.3×7.7	8×10	8×10	10×12.5	10×16.5	
220		8×10	10×10	10×16.5		
270	8×10	10×10	10×10			
330		10×10	10×12.5			
470	10×10	10×12.5	10×16.5			
560	<sup>A</sup> 10×12.5	10×16.5				

## 9. ESR

cap. \ vv	(mΩ) max. at 20 °C 100 kHz					
	16	25	35	50	63	<sup>A</sup> 80
10					120	
22				80	80	45
33			60	40	40	36
47		50	60	30	40	36
56		50			30	24
68		30	35	30	30	
82	50				30	
100		30	27	28	20	
120				28		
150	30	27	27	18	15	
220		27	20	14		
270	25	20	20			
330		20	16			
470	20	16	12			
560	<sup>A</sup> 16	12				

10. Allowable ripple

(mArms) at 125 °C or 135 °C 100 kHz

cap. \ WV	16		25		35		50		63		80
10									1000	700	
22							1100	750	1300	900	1600 1100
33					1400	900	1600	1100	1900	1100	1900 1300
47			1400	900	1400	900	2200	1250	1900	1100	1900 1300
56			1400	900					2300	1400	2800 1800
68			1900	1400	1900	1400	2200	1250	2300	1400	
82	1500	950							2300	1400	
100			1900	1400	2900	1600	2600	1600	3000	1900	
120							2600	1600			
150	2000	1500	2900	1600	2900	1600	3200	2000	4200	2500	
220			2900	1600	3300	2000	4300	2600			Rated ripple Current (mArms)
270	3100	1700	3300	2000	3300	2000					
330			3300	2000	3500	2300					
470	3400	2100	3500	2300	4800	2900					125 °C 135 °C
560 <sup>A</sup>	3600	2400	4800	2900							

\* The maximum value of ripple voltage isn't to exceed a rated voltage.

• Frequency coefficient of allowable ripple current

Frequency	120Hz	1kHz	10kHz	100kHz~
Coefficient	0.15	0.40	0.75	1.00

11. Taping

11.1 Packing form of the reel

Capacitors on tape are reeled as shown in Fig-1. Capacitors on tape are oriented in unreeling tape direction with the cathode side adjacent to the sprocket hole in the carrier tape as shown in Fig-1.

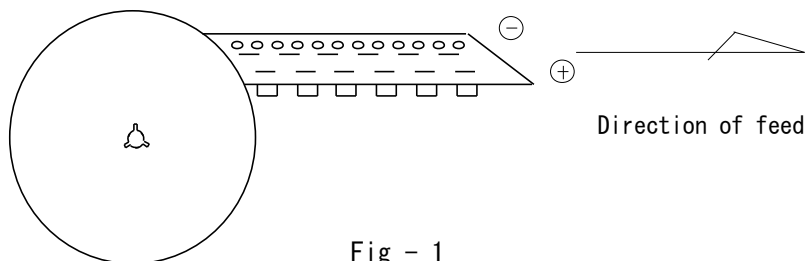

Fig - 1

11.2 Seal form of seal tape

The cover tape width will extend the edge of the carrier tape less than 0.5mm as shown in Fig-2. The cover the sprocket hole on the carrier tape less than 0.75mm as shown in Fig-3.

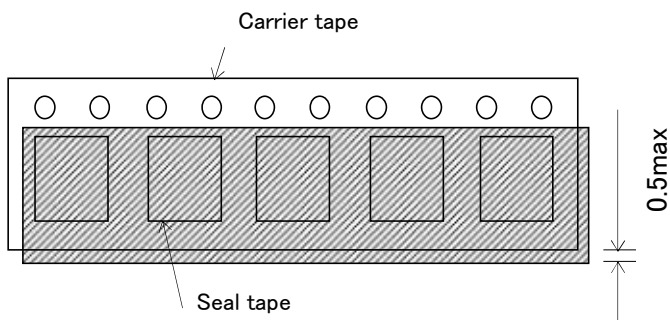

Fig-2

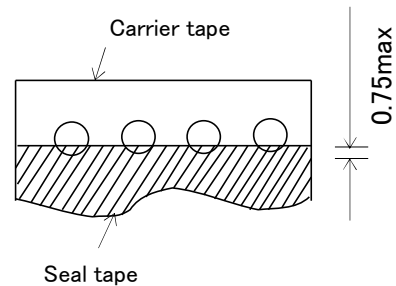

Fig-3

11.3 Splicing of the carrier tape

Splicing of the carrier tape will be done as shown in Fig-4, coverlaying the carrier tape for the direction of feed on the other side of tape and overlapping two of the end embossments each other.

The overlapped embossments will be crushed.

Three splicings in one reel are maximum.

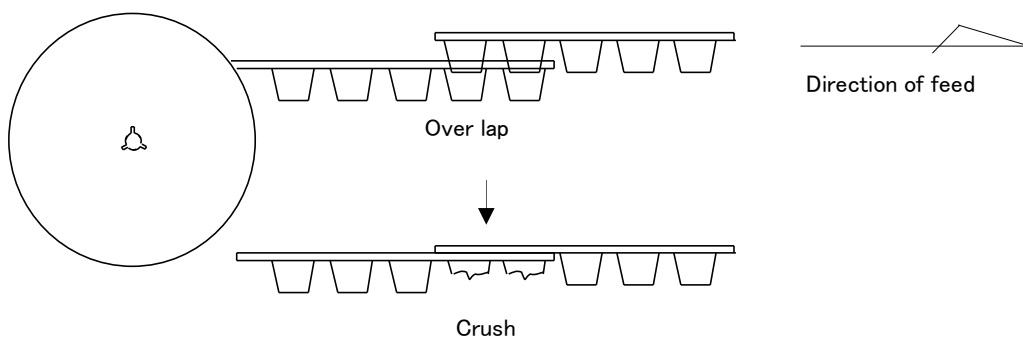

Fig - 4

11.4 Seal strength of seal tape

The seal tape will have a peel back force of 0.1N to 1.3N measured at angle of 165° to 180° with respect to the carrier tape as shown in Fig-5.

The peel off speed will be 300mm per minute.

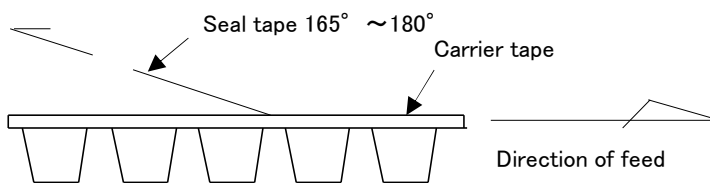
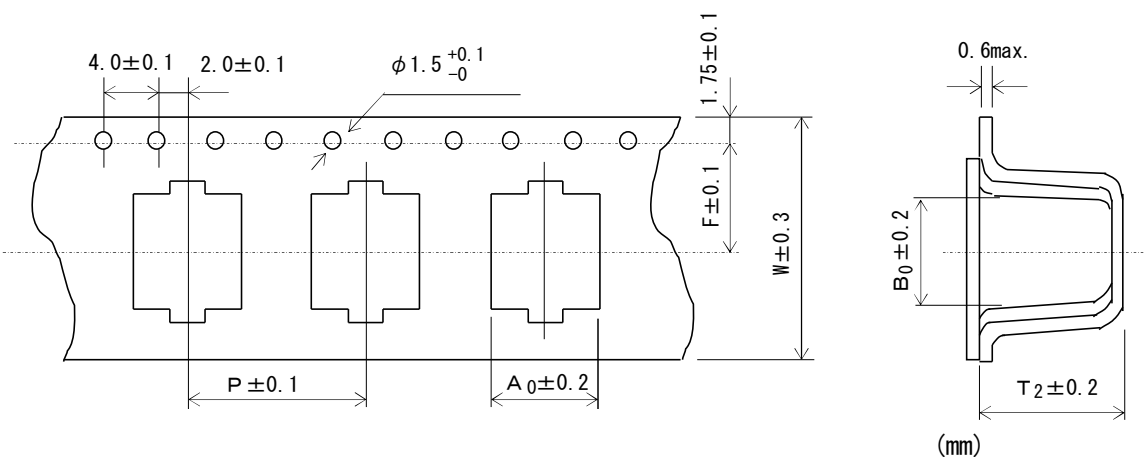

Fig - 5

11.5 Carrier tape



(mm)

$\phi D \times L$	W	P	F	$A_0$	$B_0$	$T_2$
6.3 × 5.8	16.0	12.0	7.5	7.0	7.0	6.3
6.3 × 7.7	16.0	12.0	7.5	7.0	7.0	8.0
8 × 10	24.0	16.0	11.5	8.7	8.7	11.0
10 × 10	24.0	16.0	11.5	10.7	10.7	11.0
10 × 12.5	24.0	16.0	11.5	10.7	10.7	14.1
10 × 16.5	24.0	16.0	11.5	10.7	10.7	17.65

• REEL

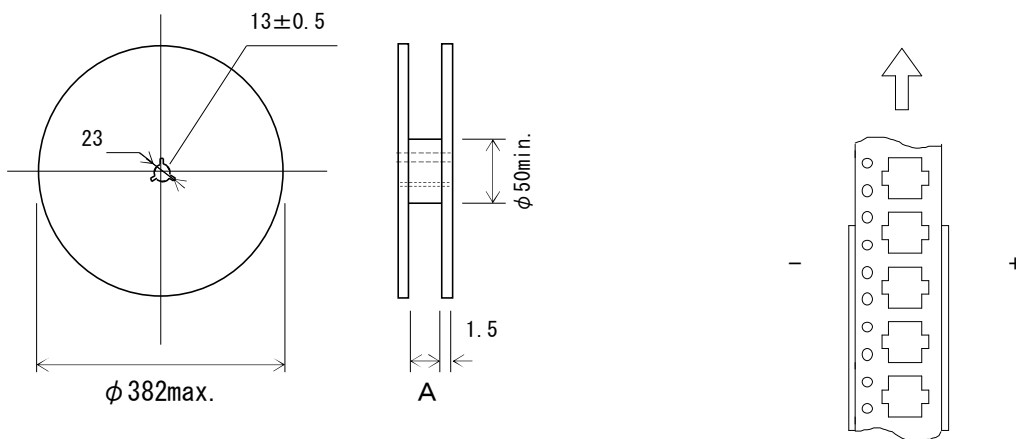

(mm)

$\phi D \times L$	6.3	8	10
A	18	26	26

12. Packing

12.1 Size of inner carton box

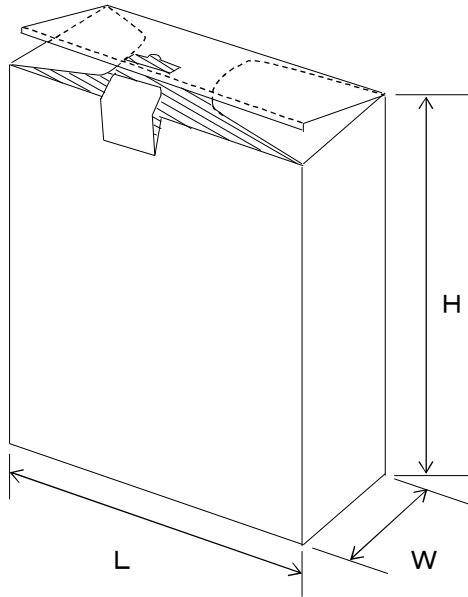

$\phi D \times L$	L	H	W
6.3 × 5.8	390	400	120
6.3 × 7.7	390	400	120
8 × 10	390	400	120
10 × 10	390	400	120
10 × 12.5	390	400	120
10 × 16.5	390	400	120

(mm)

12.2 Label information on the inner carton box

- 1) Voltage and capacitance
- 2) Nichicon part number
- 3) Quantity
- 4) Lot No.
- 5) Identification corresponding to environment.

12.3 Packaging quantity

$\phi D \times L$	1Reel	1 Carton(reels)
6.3 × 5.8	1000	5000 (5)
6.3 × 7.7	900	4500 (5)
8 × 10	500	2000 (4)
10 × 10	500	2000 (4)
10 × 12.5	400	1600 (4)
10 × 16.5	300	1200 (4)

( ): Number of reels.

13. Reflow soldering conditions

Please refer to the profile below for setting the temperature while soldering the surface mount type conductive polymer hybrid aluminum electrolytic capacitors through the reflow furnace.

The temperature between the case top and the terminal of capacitor may not be equal depending on the process parameters (e.g. the reflow method, the reflow furnace, the PC board type and etc). Nevertheless, the capacitor temperature shall not exceed the profile below at any place.

• Air reflow

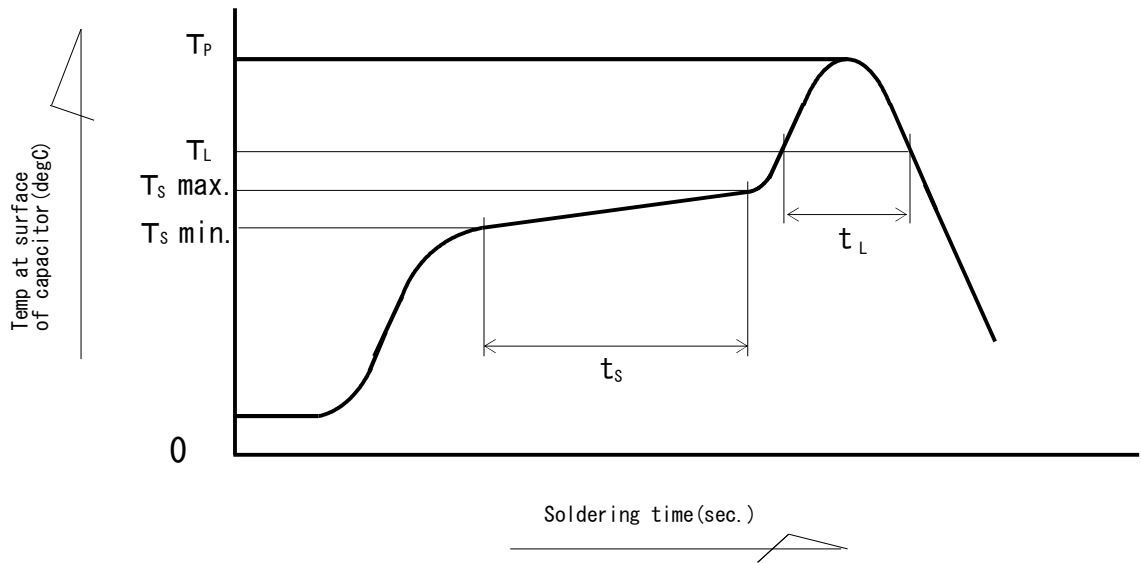

• Recommended soldering conditions.

Item	T <sub>S</sub> min	T <sub>S</sub> max	t <sub>s</sub>	T <sub>L</sub>	t <sub>L</sub>	T <sub>peak</sub>	Reflow cycles
condition 1	150°C	180°C	120sec	230°C	40sec	260°C	1
condition 2	150°C	180°C	120sec	230°C	30sec	250°C	2

Note:

Recommended solder paste thickness : 150 μm

#### 14. Precautions of Soldering

- (1) The capacitor shall not be subjected to either flow soldering or dip-soldering.
- (2) The temperature setting for reflow soldering differs depending on the exact method employed and the kind of cream solder used. In particular, in the case of hot-plate reflow, the temperature recorded at the capacitor terminal is apt to be higher than that on the capacitor surface. However, for infrared-ray and air reflow methods, the opposite is true and the temperature on the surface of the capacitor is likely to be higher than that near the terminals. Therefore, the temperature shall be set at whichever is higher for each method.
- (3) Since conductive polymer hybrid aluminum electrolytic capacitors are filled with electrolyte, their resistance to heat is not as good as that of other types of electronic components. On setting the reflow conditions, the surface temperature should not exceed 260degC. (For reflow ovens in particular, there is a possibility that the surface temperature could become much higher than round the terminals. If any abnormality is evident after soldering then the surface temperature of the capacitor should be checked immediately).
- (4) Because the recommended reflow soldering conditions shown above are used as a reference, it is likely that there will be no problems encountered even at higher temperatures. However this will depend on the heat conduction properties of the reflow oven, the quantity, proximity and location of other components on the PCB and the material of the PCB itself. It is therefore advisable to confirm the reflow conditions in advance, and in the event that the actual conditions differ markedly from the recommended ones, please contact us.
- (5) Even though reflow soldering may have to be repeated several times to satisfy the requirements of a particular process, conductive polymer hybrid aluminum electrolytic capacitors should be limited to a single pass. If this type of capacitor must be subjected to more than one reflow operation then sufficient cooling time should be given between the first and the second reflow (at least 30 minutes).
- (6) Touch up work with a soldering iron is allowed after reflow soldering is complete (temperature of soldering iron: 350degC, Time: 3 sec.), provided that careful attention is paid to avoid touching the capacitor can directly or the plastic platform.
- (7) Vapour phase soldering may use temperatures as low as 215degC, but the heat stress to the capacitor can be large due to its high heat conduction. We therefore recommend customers do not use this method.

15. Recommended PCB land pattern

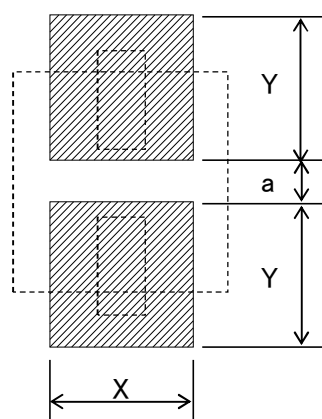

Standard

$\phi D \times L$	X	Y	a
6.3×5.8	1.6	3.5	1.9
6.3×7.7	1.6	3.5	1.9
8×10	2.5	3.5	3.0
10×10	2.5	4.0	4.0
10×12.5	2.5	4.0	4.0
10×16.5	2.8	4.3	3.5

Vibration resistance

$\phi D \times L$	X	Y	a
6.3×7.7	3.0	4.0	1.6
8×10	4.3	5.3	2.0
10×10	4.3	5.6	3.3
10×12.5	4.3	5.6	3.3
10×16.5	4.3	5.6	3.3

16. Resistance to cleaning agent

(1) Applicable cleaning agents

Pine Alpha ST-100S, Clean Through 750H/750L/710M, Sanelek b-12, Aqua Cleaner 210SEP, Techno Care FRW14~17, Iso-propyl Alcohol

(2) Cleaning condition

Total cleaning time shall be within 5 minutes by immersion, ultrasonic or other method. (Temperature of the cleaning agent shall be 60degC or lower)

Let dry for more than 10 minutes in a hot-air cleaning after capacitor along with the printed circuit board. In addition, the temperature of this hot air should be the maximum operating temperature below.

17. Precautions in using conductive polymer hybrid aluminum electrolytic capacitors

- (1) If you should reverse the polarities of a DC electrolytic capacitor, it would lead to short-circuited circuitry and may further result in an explosion if the unit kept energized.
- (2) Avoid using capacitors in the circuit where the rapid charge / discharge are repeated.
- (3) Do not apply any overvoltage exceeding the rated voltage (surge voltage for short period.)
- (4) Do not allow any higher ripple currents than rated to flow through a capacitor.
- (5) Do not use for a place exceeding the rated temperature range.
- (6) Whenever you use a capacitor that has been long stored, make sure to gradually increase the voltage to the rated value.
- (7) Be careful not to subject the terminal of capacitors to excessive force.

## 18. Others

- Export Trade Control Ordinance
  - (1) Export Trade Control Ordinance (Section 1 through 15 of Appendix Table 1)  
The aluminum electrolytic capacitors, which are described in this specification, are not applicable to Export Trade Control Ordinance (Section 1 through 15 of Appendix Table 1)
  - (2) Export Trade Control Ordinance (Section 16 of Appendix Table 1)  
The aluminum electrolytic capacitors, which are described in this specification, applicable to goods under Export Regulations based on Section 16 of Appendix Table 1 in Export Trade Control Ordinance. In case that there is a certain danger of the products conflicting with the use and activity for the developments of weapons of mass destruction, the procedures based upon the relevant export regulation laws are absolutely needed.
  
- Ozone Depleting Substances  
Ozone depleting substances are not used in our production process and at our suppliers.
  
- Brominated Flame Retardants  
The restricted brominated flame retardants are not used.
  
- Our products do not contain the restricted substances more than the maximum concentration values of the EU RoHS Directive. (RoHS 2015/863)  
(Lead, Mercury, Cadmium, Chromium(VI), PBB, PBDE, DEHP, BBP, DBP, DIBP)
  
- Please note that calculated lifetime is for reference only and not guaranteed.
  
- Voltage treatment  
The capacitor should serially attached to a protective resistor of about 1k $\Omega$  and rated voltage is applied for 2 hours at 105 $\pm$ 2degC. Next, the capacitor should be discharged through a resistor of about 1 $\Omega$ /V and it shall then be subjected to standard atmospheric condition for 24 hours.

Structure for JIS-32 Type  
Conductive polymer hybrid aluminum electrolytic capacitor

GYC series (Pb free)

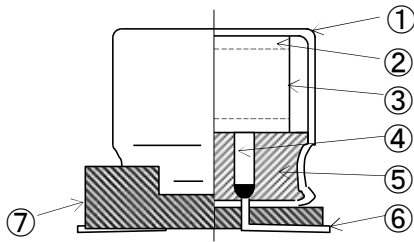

N o.	ITEM	MATERIALS	
①	Aluminum case	Laminated aluminum	
②	Element	Foil	High-purity Aluminum foil
		Separator	Non wood fiber
	Electrolyte	Conductive polymer and Electrolyte	
③	Winding affixing material	Polyphenylene sulfide Tape	
④	Lead tab	High-purity aluminum	
⑤	Rubber end seal	Synthetic rubber	
⑥	Lead wire	Tinned CP wire	
A ⑦	Plastic Platform	P.P.S. resins <del>or P.P.A. resins</del>	



## APPLICATION GUIDELINES FOR CONDUCTIVE POLYMER HYBRID ALUMINUM ELECTROLYTIC CAPACITORS

### 1. Circuit Design

- (1) Please make sure the application and mounting conditions to which the capacitor will be exposed to are within the conditions specified in alternate product specification (Referred to as specification here after).
- (2) Operating temperature and applied ripple current shall be within the specification.
  - ① The capacitor shall not be used in an ambient temperature which exceeds the operating temperature specified in the specification.
  - ② Do not apply excessive current which exceeds the allowable ripple current.
- (3) Appropriate capacitors which comply with the life requirement of the products should be selected when designing the circuit.
- (4) Aluminum electrolytic capacitors are polarized. Make sure that no reverse voltage or AC voltage is applied to the capacitors. Please use bi-polar capacitors for a circuit that can possibly see reversed polarity. Note : Even bi-polar capacitors can not be used for AC voltage application.
- (5) Avoid using capacitors in the circuit where the rapid charge / discharge are repeated. Please consult us when capacitors to be used in such circuit. Please do not apply a rush current that is larger than 10 A.
- (6) Make sure that no excess voltage (that is, higher than the rated voltage) is applied to the capacitor.
  - ① Please pay attention so that the peak voltage, which is DC voltage overlapped by ripple current, will not exceed the rated voltage.
  - ② In the case where more than 2 aluminum electrolytic capacitors are used in series, please make sure that applied voltage will be lower than rated voltage and the voltage will be applied to each capacitor equally using a balancing resistor in parallel with the capacitors.
- (7) Capacitors should be electrically isolated completely at the following points.
  - ① Case and negative terminal (except axial leaded part such as JIS configuration 02 type). Case and positive terminal. Case and circuit pattern.
  - ② Auxiliary terminal of can type such as JIS style symbol 693, 694 or 695 and negative terminal and positive terminal, including the circuit pattern.
  - ③ Case and both terminals of a bi-polarized capacitor.
- (8) Outer sleeve of the capacitor is not guaranteed as an electrical insulator. Do not use a standard sleeve on a capacitor in applications that require the electrical insulation. When the application requires special insulation, please contact our sales office for details.
- (9) Capacitors may fail if they are used under the following conditions.
  - ① Environmental (climatic) conditions
    - (a) Being exposed to water, high temperature & high humidity atmosphere, or condensation of moisture.
    - (b) Being exposed to oil or an atmosphere that is filled with particles of oil.
    - (c) Being exposed to salty water or an atmosphere that is filled with particles of salt.
    - (d) In an atmosphere filled with toxic gasses (such as hydrogen sulfide, sulfurous acid, nitrous acid, chlorine, bromine, methyl bromide, ammonia, etc.).
    - (e) Being exposed to direct sunlight, ozone, ultraviolet ray, or radication.
    - (f) Being exposed to acidic or alkaline solutions.
  - ② Under severe conditions where vibration and / or mechanical shock exceed the applicable ranges of the specifications.



## APPLICATION GUIDELINES FOR CONDUCTIVE POLYMER HYBRID ALUMINUM ELECTROLYTIC CAPACITORS

- (10) When designing a P.C. board, please pay attention to the following.
- ① Have the hole spacing on the P.C. board match the lead spacing of the capacitor.
  - ② There should not be any circuit pattern or circuit wire above the capacitor pressure relief vent.
  - ③ Unless otherwise specified, following clearance should be made above the pressure relief vent.
 

Case diameter	Clearance
under $\phi 16$	: 2 mm or more
$\phi 18$ to $\phi 35$	: 3 mm or more
$\phi 40$ or more	: 5 mm or more
  - ④ In case the vent side is placed toward P.C. board (such as end seal vented parts), make a corresponding hole on the P.C. board to release the gas when vent is operated. The hole should be made to match the capacitor vent position.
  - ⑤ Screw terminal capacitors must be installed with their end seal side facing up. When you install a screw terminal capacitor lying down, the upper side must be the pressure relief vent or a positive terminal.
- (11) The main chemical solution of the electrolyte and the separator paper used in the capacitors are combustible. The electrolyte is conductive. When it comes in contact with the P.C. board, there is a possibility of pattern corrosion or short circuit between the circuit pattern which could result in smoking or catching fire. Do not locate any circuit pattern beneath the capacitor end seal.
- (12) Do not design a circuit board so that heat generating components are placed near an aluminum electrolytic capacitor or reverse side of P.C. board (under the capacitor).
- (13) Please refer to the pad size layout recommendations in our specification when designing insurface mount capacitors.
- (14) Electrical characteristics may vary depending on changes in temperature and frequency. Please consider this variation when you design circuits.
- (15) When you mount capacitors on the double-sided P.C. boards, do not place capacitors on circuit patterns or over on unused holes.
- (16) The torque for terminal screw or brackets screws shall be within the specified value on Nichicon's drawings.
- (17) When you install more than 2 capacitors in parallel, consider the balance of current flowing through the capacitors.
- (18) If more than 2 aluminum electrolytic capacitors are used in series, make sure the applied voltage will be lower than the rated voltage and that voltage will be applied to each capacitor equally using a balancing resistor in parallel with each capacitor.

### 2. Mounting

- (1) Once a capacitor has been assembled in the set and power applied, even if a capacitor is discharged, an electric potential (restricking voltage) may exist between the terminals.
- (2) Electric potential between positive terminal and negative terminal may exist as a result of returned electromotive force, so please discharge the capacitor using a 1 k $\Omega$  resistor.
- (3) Leakage current of the parts that have been stored for more than 2 years may increase. If leakage current has increased, please perform a voltage treatment using 1 k $\Omega$  resistor.
- (4) Please confirm ratings before installing capacitors on the P.C. board.
- (5) Please confirm polarity before installing capacitors on the P.C. board.
- (6) Do not drop capacitors on the floor, nor use a capacitor that was dropped.



## APPLICATION GUIDELINES FOR CONDUCTIVE POLYMER HYBRID ALUMINUM ELECTROLYTIC CAPACITORS

- (7) Do not damage the capacitor while installing.
- (8) Please confirm that the lead spacing of the capacitor matches the hole spacing of the P.C. board prior to installation.
- (9) Snap-in can type capacitor such as JIS style symbol 692, 693, 694 and 695 type should be installed tightly to the P.C. board (allow no gap between the P.C. board and bottom of the capacitor).
- (10) Please pay attention that the clinch force is not too strong when capacitors are placed and fixed by an automatic insertion machine.
- (11) Please pay attention to that the mechanical shock to the capacitor by suction nozzle of the automatic insertion machine or automatic mounter, or by product checker, or by centering mechanism.
- (12) Hand soldering
  - ① Soldering condition shall be confirmed to be within the specification.
  - ② If it is necessary that the leads must be formed due to a mismatch of the lead space to hole space on the board, bend the lead prior to soldering without applying too much stress to the capacitor.
  - ③ If you need to remove parts which were soldered, please melt the solder enough so that stress is not applied to lead.
  - ④ Please pay attention so that soldering iron does not touch any portion of capacitor body.
- (13) Flow soldering (Wave solder)
  - ① Capacitor body must not be submerged into the solder bath. Capacitors must be mounted on the "top side" of the P.C. board and only allow the bottom side of the P.C. board to come in contact with the solder.
  - ② Soldering condition must be confirmed to be within Nichicon's specification.
  - ③ Please avoid having flux adhere to any portion except the terminal.
  - ④ Please avoid contact between other components and the capacitor.
- (14) Reflow soldering (SMD only)
  - ① Soldering condition must be confirmed to be within Nichicon's specification.
  - ② When an infrared heater is used, please pay attention to the extent of heating since the absorption rate of infrared, will vary due to difference in the color of the capacitor body, material of the sleeve and capacitor size.
- (15) Soldering flux

There are non-halogen types of flux that do not contain ionic halides, but contain many non-ionic halides. When these non-ionic halides infiltrate the capacitor, they cause a chemical reaction that is just as harmful as the use of cleaning agents.  
Use soldering flux that does not contain non-ionic halides.
- (16) Shrinkage, bulging and / or cracking could be seen on the outer sleeve of the capacitor when capacitors are kept in for more than 2 minutes at 150 °C ambient temperature during soldering at reflow process or resin curing process. Applying high temperature gas or heat ray to capacitor can cause the same phenomenon.
- (17) Do not tilt lay down or twist the capacitor body after the capacitor are soldered to the P.C. board.
- (18) Do not carry the P.C. board by grasping the soldered capacitor.
- (19) Please do not allow anything to touch the capacitor after soldering. If P.C. board are stored in a stack, please make sure P.C. board or the other components do not touch the capacitor. The capacitors shall not be affected by any radiated heat from the soldered P.C. board or other components after soldering.



## APPLICATION GUIDELINES FOR CONDUCTIVE POLYMER HYBRID ALUMINUM ELECTROLYTIC CAPACITORS

### (20) Cleaning

- ① Do not clean capacitors with halogenated cleaning agent. If it is necessary to clean with halogenated cleaning agent, use cleaning proof capacitors and within the range specified in products specification.
- ② Avoid to use ozone depleting substance as a cleaning agent conserving global environmental protection.
- ③ Please consult us regarding other cleaning agents or cleaning methods.

### (21) Fixing Material and Coating Material

- ① Do not use any affixing or coating materials, which contain halide substance.
- ② Remove flux and any contamination, which remains in the gap between the end seal and P.C. board.
- ③ Please dry the cleaning agent on the P.C. board before using affixing or coating materials.
- ④ Please do not apply any material all around the end seal when using affixing or coating materials.

There are variations of cleaning agents, fixing and coating materials, so please contact those manufacture or our sales office to make sure that the material would not cause any problems.

### (22) Others

When halogen contained in a fumigation agent enters the capacitors, it may chemically react with the electrolytic solution, electrode foil, etc. inside. (Some gases mainly permeate the sealing parts of the capacitors and they enter the capacitors.)

When this chemical reaction progresses further, the capacitors may cause a leakage current failure, opening failure, pressure valve operation, etc. due to the corrosion of the aluminum materials inside.

The capacitors may be fumigated by halogen compounds, such as methyl bromide, when they are exported or being used to protect them against pests.

When fumigating capacitors and devices embedded with capacitors and when using packing materials, such as a pallet, that have been fumigated, be very careful so that the capacitors are not exposed to the halogen atmosphere.

## 3. In the equipment

- (1) Do not directly touch either terminal by hand to avoid getting an electric shock.
- (2) To avoid any potential scalding, do not allow a capacitor to come incontact or close proximity with your hands or any exposed skin. The pressure relief vent operates when a capacitor gets overheated or has been subject to abnormal conditions. The steam emitted can exceed 100 °C.
- (3) Do not make a capacitor short-circuited between its terminals with conductor, nor spill conductible liquid such as alkaline or acidic solution on or near the capacitor.
- (4) Please make sure that the ambient conditions where the appliance is installed have none of the following conditions :
  - ① Where capacitors are exposed to water, high temperature & high humidity atmosphere, or condensation of moisture.
  - ② Where capacitors are exposed to oil or an atmosphere that is filled with particles of oil.
  - ③ Where capacitors are exposed to salty water, high temperature & high humidity atmosphere, or condensation of moisture.
  - ④ The atmosphere is filled with toxic acid gasses (e.g. hydrogen sulfide, sulfurous acid, nitrous acid, chlorine, bromine, methyl bromide, etc.)
  - ⑤ The atmosphere is filled with toxic alkaline gasses (e.g. ammonia)
  - ⑥ Where capacitors are exposed to acidic or alkaline solutions.
  - ⑦ Since shrinkage, bulging and / or crack could be seen on outer sleeve of capacitor when capacitors are used in atmosphere where condensation of moisture occurs, please confirm their adaptation before the use. The condensation of moisture could occur when temperature cycling test / Rapid change of temperature test is performed, in this case, aforementioned sleeve problem could be seen.



## APPLICATION GUIDELINES FOR CONDUCTIVE POLYMER HYBRID ALUMINUM ELECTROLYTIC CAPACITORS

### 4. Maintenance Inspection

- (1) Please periodically inspect the aluminum capacitors that are installed in industrial equipment. The following items should be checked.
  - ① Appearance : Remarkable abnormality such as vent operation, leaking electrolyte etc..
  - ② Electrical characteristics : Capacitance, dielectric loss tangent, leakage current, and items specified in the specification.

### 5. Emergency

- (1) In case when the capacitor is damaged by short-circuit etc during operation, turn off the main switch of the equipment or pull out the plug from an outlet.

### 6. Storage

- (1) It is recommended to keep capacitors between the ambient temperatures of 5 to 35 °C and a relative humidity of 75 % or below.
- (2) Please make sure the ambient storage conditions will be free from the conditions that are listed in clause 3. "In the equipment" at (4).
- (3) In order to maintain a good solderability of the parts, shelf life of parts should not exceed 1 year.

### 7. Disposal

- (1) Take either of the following methods in disposing of capacitors.
  - ① Make a hole in the capacitor body or crush capacitors and incinerate them.
  - ② If incineration is not applicable, hand them over to a waste disposal agent and have them buried in a land fill.
- (2) When removing a capacitor from the circuit board or when disposing of capacitor please ensure that the capacitor is properly discharged.

The above mentioned material according to JEITA RCR - 2367D (issued in October, 2017), titled "Safety Application Guide for fixed aluminium electrolytic capacitors for use in electronic equipment". Please refer to the book for details.

Issued by April, 2020