

# Safety Light Curtain

F3SG-R Series

## More Rugged

Advanced, Robust, and Easy types

**NEW**  
Robust type

Advanced type

Easy type



# Increase both durability and productivity

The new cutting oil resistant Robust type is added



## Safety Light Curtain F3SG-R Series

Fast set-up and high resistance to environmental changes

### Tough 1 Resistant to vibration

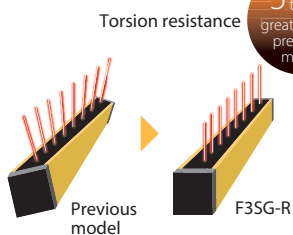

Previous model

F3SG-R

### Tough 2 Robust against environmental changes

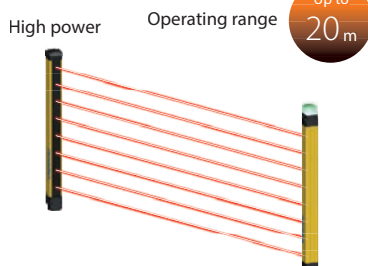

High power

Operating range

Up to 20 m

### Tough 3 Reliable in dusty wash-down environments



F3SG-RR IP67G

F3SG-RA/RE:IP67

\* Compared to the previous model (Omron survey as of March 2017)

**A choice of products to suit your need** Multiple versions available: finger, hand and arm protection

### Ideal for flexible manufacturing

Multifunctional **Advanced** type



**F3SG-RA**

- Quick and easy installation
- Stable operation and predictive maintenance
- For global use
- Easy adjustment
- Easy configuration and maintenance

>>p.4

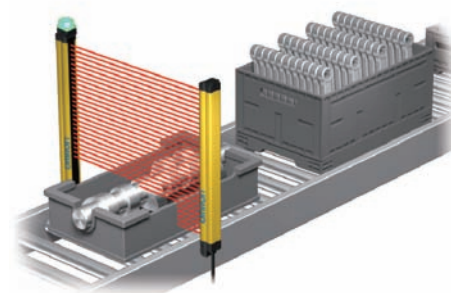

### Even for environments where cutting oil is present

Cutting oil resistant **Robust** type



**F3SG-RR** **NEW**

- Four times longer\* cutting oil resistance
- No dead space
- IP67G

\* Compared to the previous model (Omron survey as of March 2017)

>>p.10

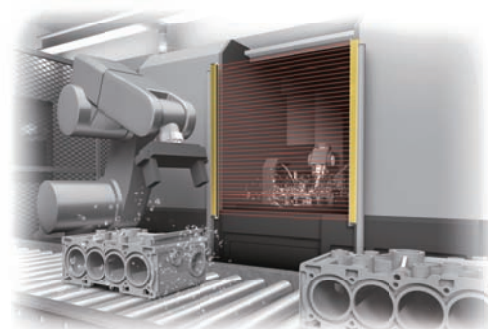

### Ideal for simple applications

Simple **Easy** type



**F3SG-RE**

- Simple functions
- Reduced wiring
- Fast response time: 5 ms

>>p.11



- STI is a trademark or registered trademark of OMRON Corporation in Japan and other countries.
- Microsoft product screen shot(s) reprinted with permission from Microsoft Corporation.
- The Bluetooth® word mark and logos are registered trademarks owned by Bluetooth SIG, Inc. Any use of such marks by Omron is under license.
- Other company names and product names in this document are the trademarks or registered trademarks of their respective companies.

Multifunctional  
Advanced  
type  
**F3SG-RA**

Quick and easy installation

# Intuitive and smart designs for fast set-up

TOP  
(top-beam-state indicator)

## Simple beam adjustment

Simply watch for the top and bottom indicators to illuminate when adjustment is completed.  
The optional laser pointer and lamp can be used to reduce the time required to set up the light curtain.

1 The TOP indicator turns ON when the top beam is unblocked

F39-PTG Laser Pointer

Shows the sensor direction



F39-LP Lamp

Turns ON when safety output turns ON, making adjustment easier



Also The incident light levels of each beam can be checked with the Configuration Tool SD Manager2

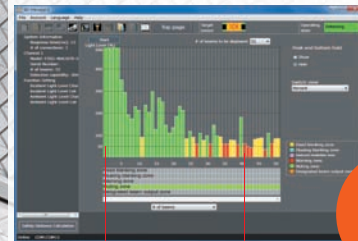

Sufficient Green  
Insufficient Red

Fine beam adjustment

2 The BTM indicator turns ON when the bottom beam is unblocked

BTM

(bottom-beam-state indicator)

\* Image for illustration purpose only.

## Mounting brackets

Four types of mounting brackets provide vertical or vertical and horizontal adjustment even after mounting, making beam adjustment easier.

### Standard fixed bracket

You can slide the F3SG-R up and down to make vertical adjustments after mounting on a safety fence.



### Standard adjustable bracket (sold separately)

This bracket provides vertical as well as horizontal adjustment of  $\pm 15^\circ$ .



### Top/bottom adjustable bracket (sold separately)

Use this bracket at the top and bottom of the F3SG-R to make horizontal adjustment of  $\pm 22.5^\circ$ .



### Top/bottom adjustable bracket (for user-made mounting part) (sold separately)

The wall mounting bracket is not provided so that you can design your own wall mounting part.

## Optical synchronization – No sync lines required

Optical synchronization eliminates the need of wiring for synchronization between the emitter and receiver. The resulting flexible wiring reduces disconnection risk and avoids noise sources.

### Optical synchronization

**Start-up**

The top or bottom beam of the emitter starts synchronizing with the corresponding beam of the receiver.



**After sync**

Once synchronization is done, the emitter is kept synchronized with the receiver while at least one beam is unblocked.



## Smartclick cable connection for fast set-up

No torque-control required: the Smartclick connectors connect cables with just a 1/8th turn of the M12 waterproof connector.

\* Smartclick is a registered trademark of OMRON Corporation.



## Simple wiring thanks to reduced wiring connectors

Simple wiring makes installation faster. Fewer cables reduce disconnection risk and noise trouble.

### Previously

Cables of the emitter and receiver

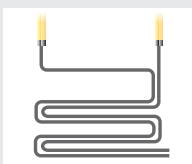

### Only one cable

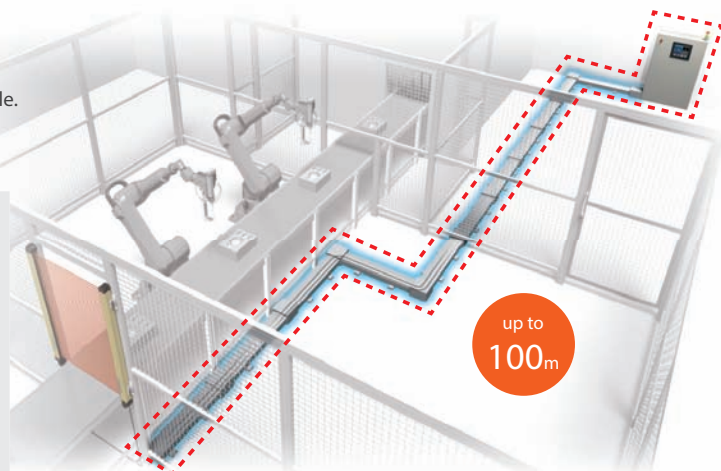
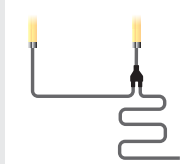

Multifunctional  
Advanced  
type  
F3SG-RA

Stable operation and predictive maintenance

# Visualization eliminates machine downtime

## The lamp notifies low light intensity

The lamp notifies when the incident light level drops due to dirt, which prevents sudden stops.

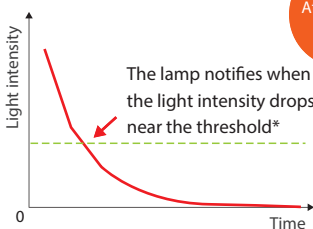

\* The incident light level at which the light curtain turns OFF



F39-LP Lamp

## Data logging for quick troubleshooting

The error logs stored in the F3SG-RA can be downloaded to a PC that is connected with the F3SG-RA using the dedicated interface unit. The Configuration Tool SD Manager2 can be used to analyze errors to identify causes and solutions. The data on light intensity, power-ON time, and switching frequency can also be collected regularly for predictive maintenance.

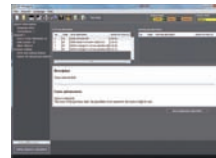

Configuration Tool SD Manager2

## Bluetooth® allows to check status without stopping the line

The SD Manager2 can be used to check the status of the safety light curtain wirelessly after pairing the safety light curtain with PC via Bluetooth®, which reduces maintenance time.

Wireless connectivity

- **Monitoring during operation**
- **No possibility of blocking beams**
- **No work required after completing checks**
- **Monitoring from anywhere**
- **Serial number to choose the right safety light curtain from many installed on lines**

F39-BT/BTLP Bluetooth®  
Communication Unit



Line A



Line B

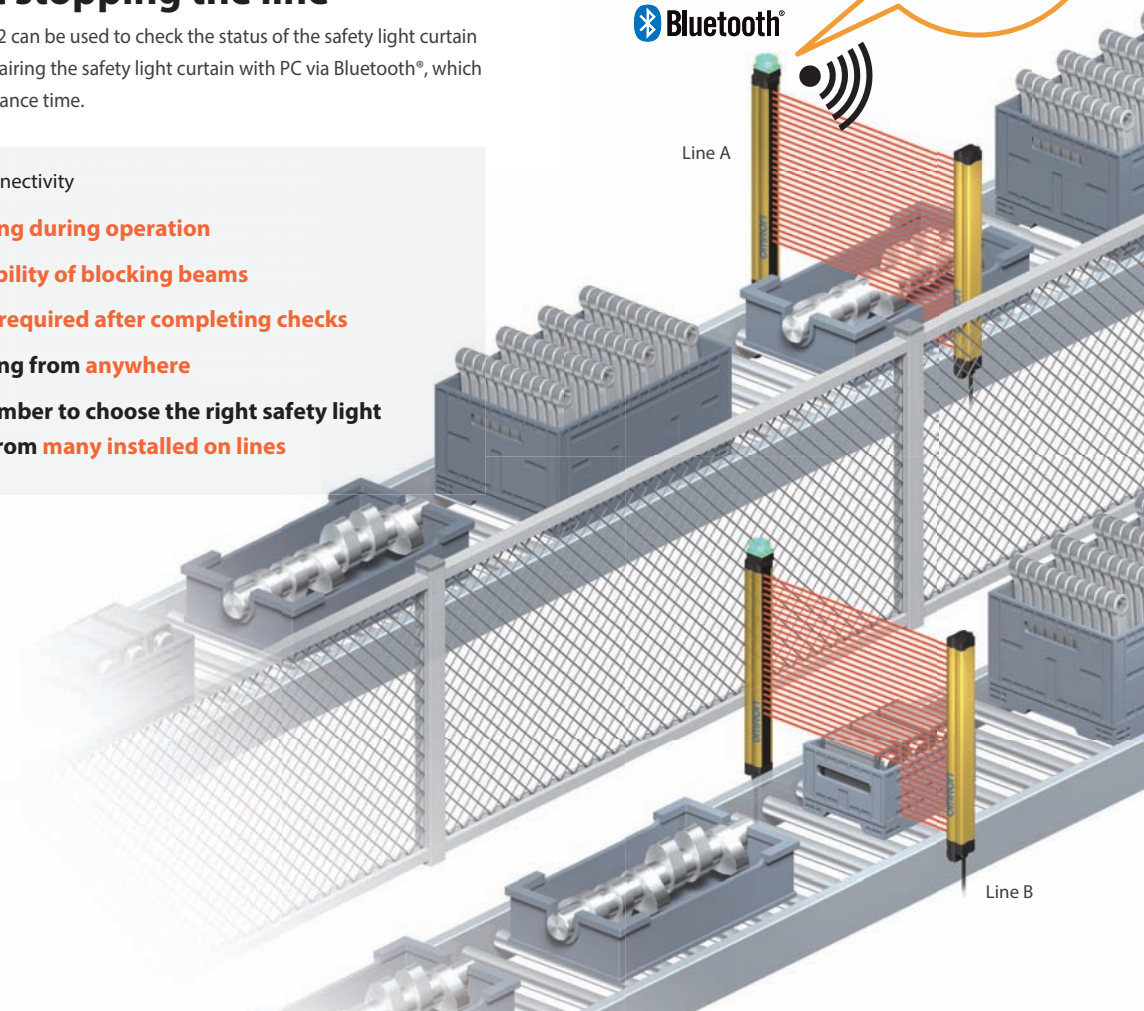

For global use

# Easy to deploy around the world

## PNP/NPN selection

The F3SG-RA is designed to be used in a variety of environments around the world, conforming to international standards.



PNP or NPN can be selected with the DIP switch. The same cables are used



The F3SG-R conforms to major international standards including Chinese GB standards

## Global production and delivery

Omron enhanced the global production bases and local services in Japan, China, United States, and Europe to deliver Omron products quickly and reliably. Our sales network of approximately 150 offices in 40 countries and regions supports our customers.



## Troubleshooting in eight languages\*

You can find causes and solutions of errors that occur during operation on the troubleshooting webpage in eight languages. Operators across the world can check the error details in their local languages, which will help them minimize time to troubleshoot.

\* English, Chinese, Italian, Korean, French, German, Spanish, and Japanese



Scan the QR code and go directly to the troubleshooting webpage

Just 15 seconds to connect!



Select the status of the indicator



Easy trouble shooting

Result	
<b>Indication status</b>	
Indicator	Receiver
LOCK OUT	Blinks 1 time
Blinking indicator	ON/OFF
<b>Description</b>	
Safety output error	
<b>Cause and measures</b>	
* Safety output lines may be short-circuited to each other or another signal line may be	

**Multifunctional  
Advanced  
type  
F3SG-RA**

Easy adjustment

# Increase productivity by detecting workpieces correctly

## Muting

The F3SG-RA provides the advanced Muting function that disables beams which detect the presence of a workpiece or the position of a machine or robot. Workpieces can go in and out of a danger zone without stopping the machine.

**Conventional Muting** Muting secured safety, but the set-up was time consuming.

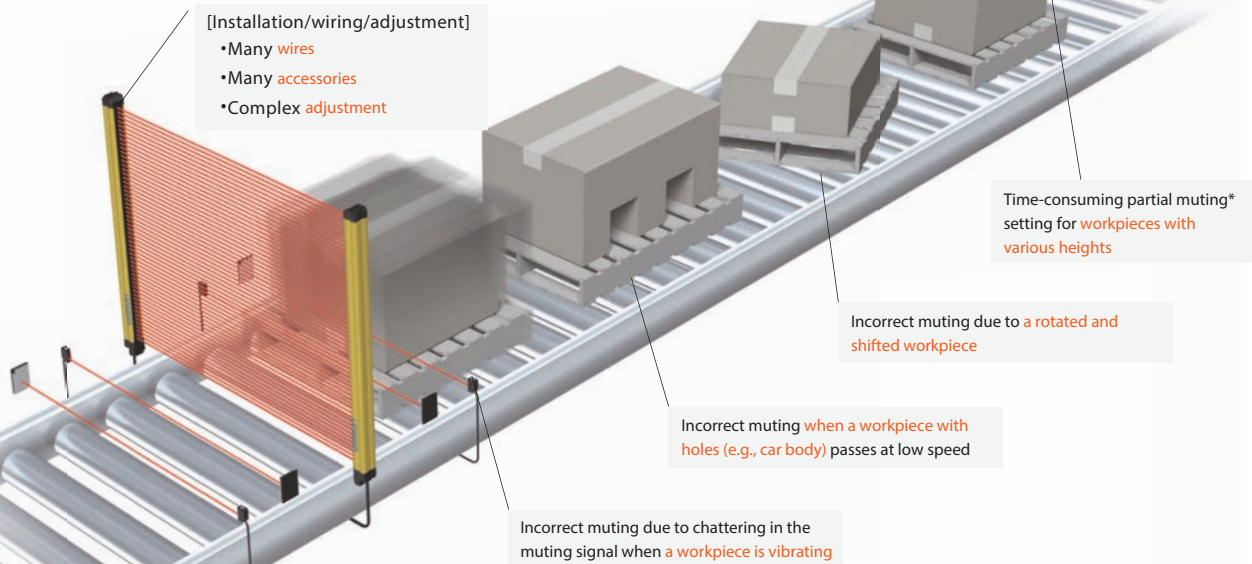

**F3SG-R** Two auto-configuration functions significantly reduce the adjustment time even under difficult conditions where failure is likely to occur.

Adjustment time reduced by **80%\***

\* Compared to the previous model (Omron survey as of March 2017)

Multiple-beam sensor technology for vibrating workpieces

### Smart muting actuator **F3W-MA**

The smart muting actuator extends the functions of the F3SG-R in applications where a workpiece is vibrating forward and backward. This prevents unexpected machine downtime and significantly reduces adjustment time.

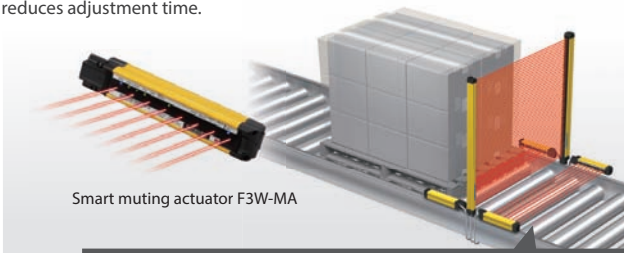

Automatic and flexible detection even under unstable conveying conditions

Automatic partial muting for workpieces with various heights

### Dynamic Muting

When workpieces with various heights are conveyed on the same line, the dynamic muting function automatically sets the appropriate beams, based on the height of the object.

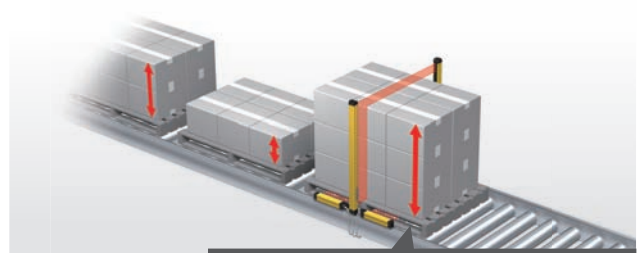

Partial muting based on the detected workpiece height

\* Partial muting: A function that allows specified beams (e.g., beams blocked by a workpiece) to be disabled, keeping others active, even during muting.

Easy configuration and maintenance

# Easy to use | Configuration Tool SD Manager2

## Minimizing setting and detection errors



Muting statistics information

The Configuration Tool SD Manager2 visualizes the installation positions and settings by logging the muting sensor operating conditions of the F3SG-R. It helps ensure reliable, first-time-right configuration.



### Examples of logging



Low risk of intermittent stop, but not safe



OK in a test run, but intermittent stop may occur during long-term operations



Test run result is out of setting range. Muting sequence error occurred

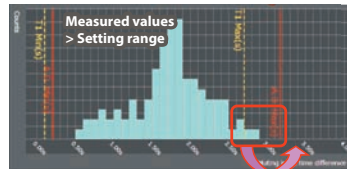
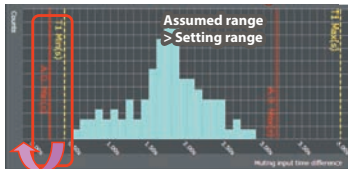
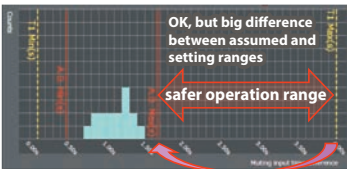

## From configuration and adjustment to maintenance

The SD Manager2 helps you to make and change settings.

Easy-to-understand icons



### Examples

#### Monitoring

Incident/ambient light level monitoring



Monitor incident light levels of each beam for fine tuning

Maintenance information



Check error log and other data required for maintenance

#### I/O Setting

Auxiliary output/lamp

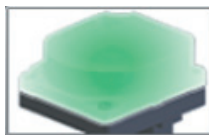

Change the settings assigned to each output including lamp color and pattern

#### Function Setting

Fixed blanking

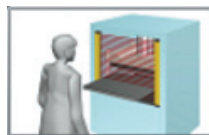

Set disabled beams manually or by teach-in

Muting/override

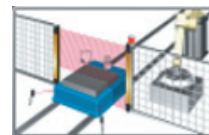

Set disabled beams and time. Setting can be evaluated

The Configuration Tool SD Manager2 is available to download from Omron website:  
[http://www.ia.omron.com/f3sg-r\\_tool](http://www.ia.omron.com/f3sg-r_tool)



NEW

Cutting oil resistant

**Robust**  
type

**F3SG-RR**

IP67G

# Robust design for reliable use even in cutting oil environments

## Four times longer\* cutting oil resistance

The F3SG-RR has the ability to protect from cutting oil (IP67G) for four times longer than the previous model.

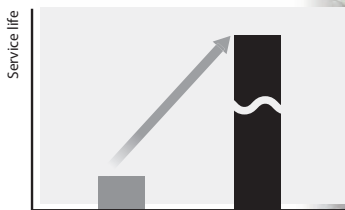

Previous model  
F3SJ-A/B

**F3SG-RR**

\* Compared to the previous model  
(Omron survey as of March 2017)

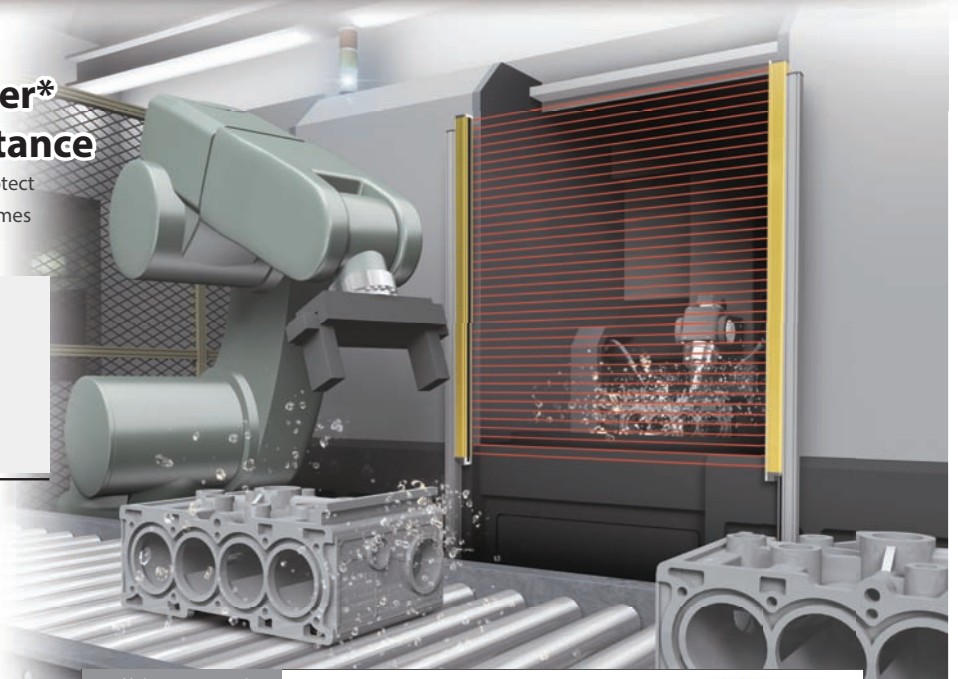

### Unique construction

#### No gaps

The optical surface is completely covered with rubber, and the metal parts placed on the rubber are compressed and deformed to seal tightly. This construction does not use double-sided tape that oil can penetrate, preventing cutting oil from getting inside.

Patented

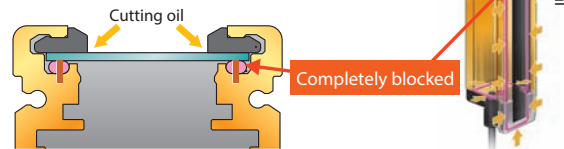

## No dead space

The F3SG-R perfectly fits to machines without wasting space. Thanks to the Cascade Connection function and perfect fit installation, you can series-connect light curtains to fit various protective heights, reducing inventories.

### The detection zone completely covers the joint

25-mm dia.

Example of 25 mm detection capability

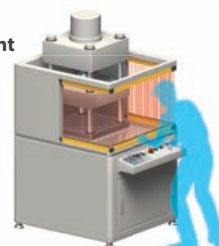
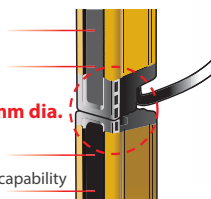

\*1. Up to three sets of F3SG-R (up to 255 beams in total) can be series-connected.

\*2. Protect cascading cables from cutting oil.

Simple  
Easy  
type  
**F3SG-RE**

Reduced wiring and fast response

# Simple ON/OFF detection

## Easy version for cost-efficiency

The Easy type inherits the robust but slim housing and basic safety features of the Advanced type. Simple ON/OFF detection reduces errors, preventing productivity from dropping.

Simple safety functions to reduce errors and save costs

Reduced to just 4 wires

Fastest response time of 5 ms

## Easier to build safety circuits

Only four wires are required for the minimum configuration, which is as simple as wiring a photoelectric sensor. Simple connection with a safety controller makes it easy to build a safety circuit.

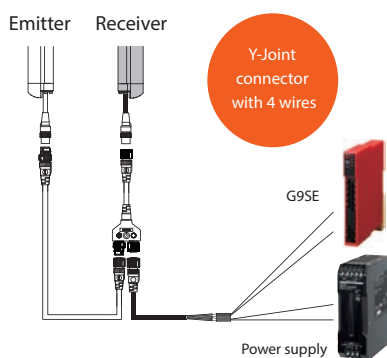

Industry's fastest class\*

## Fastest response time of 5 ms

The Easy type that allows the distance between the light curtain and hazard source to be reduced is ideal for the use in a small machine.

\* Omron survey as of March 2017

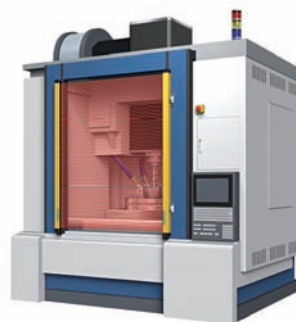



Also

### Use easy-to-obtain cables

Commercially available M12 connector cables can be used as extension cables to build a safety circuit.



























## List of specifications and features

		Advanced type		Robust type	
		F3SG-RA		F3SG-RR	
					
Application	Finger protection	●		●	
	Hand and arm protection		●		●
	Body protection				
Specification	Detection capability	14-mm dia.	30-mm dia.	14-mm dia.	25-mm dia.
	Beam gap	10 mm	20 mm	10 mm	20 mm
	Operating range	0.3 to 10 m	0.3 to 20 m	0.3 to 10 m	0.3 to 17 m
	Protective height	160 to 2,080 mm	190 to 2,510 mm	240 to 1,920 mm	
	Number of beams	15 to 207	8 to 124	23 to 191	12 to 96
Feature	PNP/NPN Selection				
	External Test		*1		*1
	Interlock				
	Pre-Reset				
	External Device Monitoring (EDM)				
	Auxiliary Output				
	Muting				
	Blanking				
	Reduced Resolution				
	Warning Zone				
	Scan Code Selection				
	Operating Range Selection				—
	Response Time Adjustment				
Designated Beam Output					
Connection/wiring	Cascade Connection				
	Reduced wiring				
Environmental resistance	Degree of protection	IP67		IP67, IP67G	
Accessory	Lamp	●		●	
	Bluetooth communication unit	●		●	
	SD Manager2	●		●	
	Laser pointer	●		●	
More information		Page 16 (F3SG-RA-01TS : Page 93, F3SG-RA-02TS : Page 120*)		Page 44	

\*1. Supports PNP/NPN by switching between 0 V and 24 V active.

\*2. The F3SG-RA-□TS has different specifications. See the pages listed above for details.

Easy type		More slim – F3SJ Series				
F3SG-RE		F3SJ-E	F3SJ-B	F3SJ-A		
 <p>Ideal for simple applications</p>						
●				●	Finger protection	Application
	●	●	●	●	Hand and arm protection	
				●	Body protection	
14-mm dia.	30-mm dia.	25-mm dia.	25-mm dia.	14/20/30/55-mm dia.	Detection capability	Specification
10 mm	20 mm	20 mm	20 mm	9/15/25/50 mm	Beam gap	
0.3 to 10 m	0.3 to 20 m	0.2 to 7 m	0.2 to 7 m	0.2 to 9 m *3	Operating range	
160 to 2,080 mm	190 to 2,510 mm	185 to 1,105 mm	185 to 2,065 mm	245 to 2,495 mm *3	Protective height	
15 to 207	8 to 124	8 to 54	8 to 102	Varies depending on the beam gap *3	Number of beams	
–	–	–	–	–	PNP/NPN Selection	Feature
–	–				External Test	
–	–	–			Interlock	
–	–	–	–	–	Pre-Reset	
–	–	–			External Device Monitoring (EDM)	
–	–	–	–		Auxiliary Output	
–	–	–			Muting	
–	–	–	–		Blanking	
–	–	–	–	–	Reduced Resolution	
–	–	–	–		Warning Zone	
–	(Not required for wired synchronization)			–	Scan Code Selection	
	–	–	–		Operating Range Selection	
–	–	–	–	–	Response Time Adjustment	
–	–	–	–		Designated Beam Output	
–	–	–			Cascade Connection	Connection/ wiring
	–	–			Reduced wiring	
IP67	IP65	IP65	IP65	IP65	Degree of protection	Environmental resistance
–	–	–	–	●	Lamp	Accessory
–	–	–	–	–	Bluetooth communication unit	
–	–	–	–	SD Manager	SD Manager2	
●	●	●	●	●	Laser pointer	
Page 73	Refer to the F3SJ Series Catalog (Cat. No. F074).				More information	



\*3. Varies depending on the model.

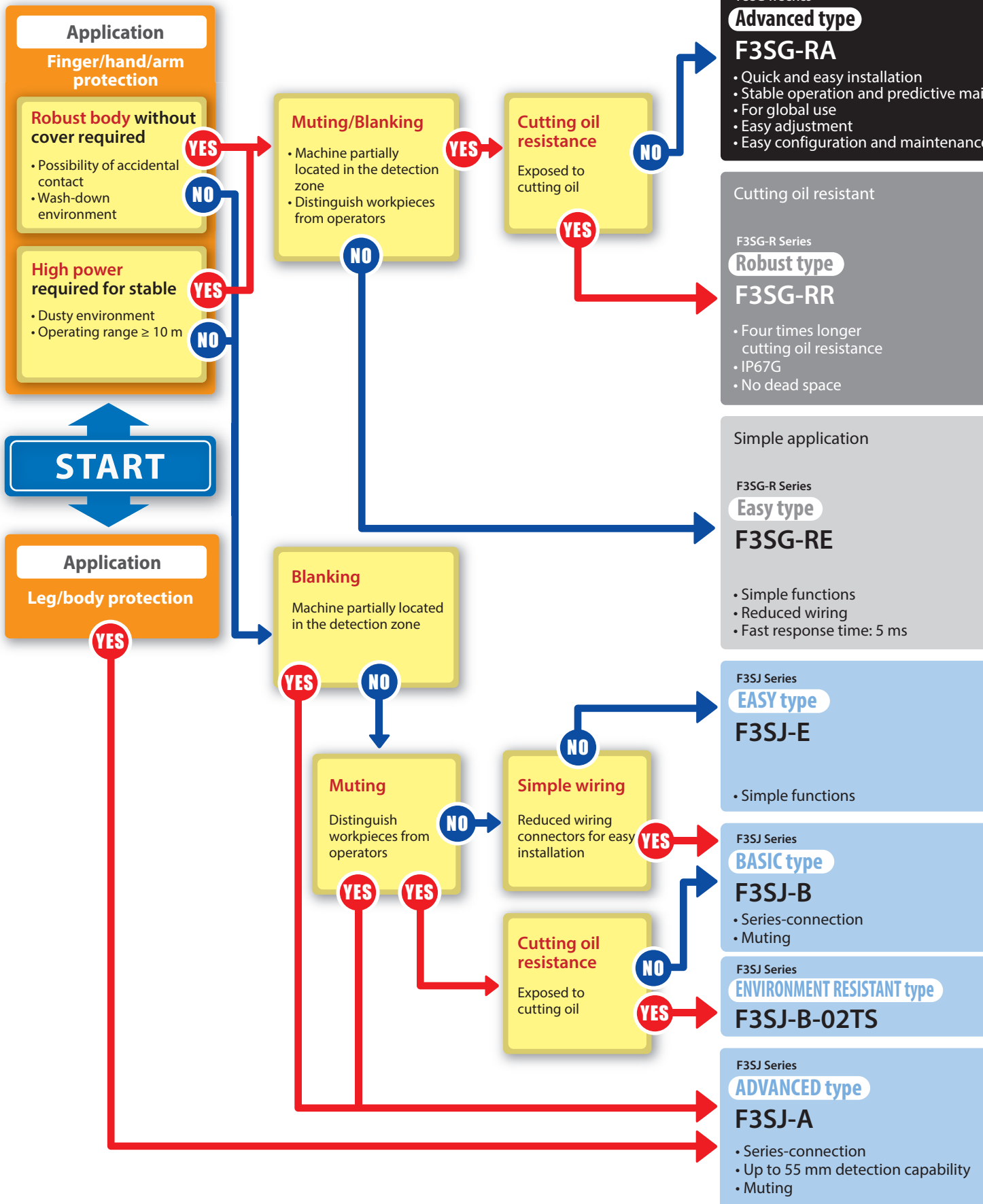

## Flowchart for product section







aintenance

e

Protective height	Specifications	Brackets	Cable	Accessories (sold separately)
 <p>14-mm dia. 160 to 2,080 mm (15 to 207 beams)</p> <p>30-mm dia. 190 to 2,510 mm (8 to 124 beams)</p>	<p><b>Detection capability</b></p> <p>14-mm dia./30-mm dia.</p> <p><b>Beam gap</b></p> <p>10 mm/20 mm</p> <p><b>Operating range</b></p> <p>0.3 to 10 m/ 0.3 to 20 m</p> <p><small>*The F3SG-RA-□TS has different specifications. See the following pages:F3SG-4RA-01TS: p. 93 F3SG-RA-02TS: p. 120</small></p>	<p><b>Accessory</b></p> <ul style="list-style-type: none"> <li>• Standard fixed bracket</li> </ul>  <p><b>Sold separately</b></p> <ul style="list-style-type: none"> <li>• Standard adjustable bracket</li> <li>• Top/bottom adjustable bracket</li> <li>• Top/bottom adjustable bracket (for user-made mounting part)</li> </ul>	<p><b>Connector</b></p> 	<ul style="list-style-type: none"> <li>Single/double-ended connector cable</li> <li>Cascading cable</li> <li>Reduced wiring connector</li> <li>Laser pointer</li> <li>Spatter protection cover</li> <li>Lamp</li> <li>Bluetoothcommunication unit</li> <li>SD Manager2</li> </ul> <p>See <b>p.16</b> for details.</p>

Protective height	Specifications	Brackets	Cable	Accessories (sold separately)
 <p>14-mm dia. 240 to 1,920 mm (23 to 191 beams)</p> <p>25-mm dia. 240 to 1,920 mm (12 to 96 beams)</p>	<p><b>Detection capability</b></p> <p>14-mm dia./25-mm dia.</p> <p><b>Beam gap</b></p> <p>10 mm/20 mm</p> <p><b>Operating range</b></p> <p>0.3 to 10 m/ 0.3 to 17 m</p>	<p><b>Sold separately</b></p> <ul style="list-style-type: none"> <li>• Free-Location Bracket (Intermediate Bracket)</li> <li>• Top/bottom Bracket (3types)</li> </ul>	<p><b>Connector</b></p> 	<ul style="list-style-type: none"> <li>Single/double-ended connector cable</li> <li>Cascading cable</li> <li>Reduced wiring connector</li> <li>Laser pointer</li> <li>Lamp</li> <li>Bluetooth communication unit</li> <li>SD Manager2</li> </ul> <p>See <b>p.44</b> for details.</p>

Protective height	Specifications	Brackets	Cable	Accessories (sold separately)
 <p>14-mm dia. 160 to 2,080 mm (15 to 207 beams)</p> <p>30-mm dia. 190 to 2,510 mm (8 to 124 beams)</p>	<p><b>Detection capability</b></p> <p>14-mm dia./30-mm dia.</p> <p><b>Beam gap</b></p> <p>10 mm/20 mm</p> <p><b>Operating range</b></p> <p>0.3 to 10 m/ 0.3 to 20 m</p>	<p><b>Accessory</b></p> <ul style="list-style-type: none"> <li>• Standard fixed Bracket</li> </ul>  <p><b>Sold separately</b></p> <ul style="list-style-type: none"> <li>• Standard adjustable bracket</li> <li>• Top/bottom adjustable bracket</li> <li>• Top/bottom adjustable bracket (for user-made mounting part)</li> </ul>	<p><b>Connector</b></p> 	<ul style="list-style-type: none"> <li>Single/double-ended connector cable</li> <li>Reduced wiring connector</li> <li>Laser pointer</li> <li>Spatter protection cover</li> </ul> <p>See <b>p.73</b> for details.</p>

Protective height	Specifications
 <p>25-mm dia. 185 to 1,105 mm (8 to 54 beams)</p>	<p><b>Detection capability</b></p> <p>25-mm dia.</p> <p><b>Beam gap</b></p> <p>20 mm</p> <p><b>Operating range</b></p> <p>0.2 to 7 m</p>

Protective height	Specifications
 <p>25-mm dia. 185 to 2,065 mm (8 to 102 beams)</p> <p><small>* ENVIRONMENT RESISTANT type Protective height: 225 to 1,985 mm Operating range: 0.2 to 6 m</small></p>	<p><b>Detection capability</b></p> <p>25-mm dia.</p> <p><b>Beam gap</b></p> <p>20 mm</p> <p><b>Operating range</b></p> <p>0.2 to 7 m</p>

Protective height	Specifications
 <p>14-mm dia. 245 to 1,271 mm (26 to 140 beams)</p> <p><small>*When the minimum object resolution is 14 mm and the beam gap is 9 mm.</small></p>	<p><b>Detection capability</b></p> <p>14-mm dia. -</p> <p><b>Beam gap</b></p> <p>9 mm -</p> <p><b>Operating range</b></p> <p>0.2 to 9 m</p>

Refer to the F3SJ Series Catalog (Cat. No. F074) or visit the Omron website for details of the F3SJ Series.



[www.ia.omron.com/](http://www.ia.omron.com/)

F3SJ

Search

# Safety Light Curtain Advanced type

# F3SG-RA

## Offers Both Durability and Reliability

- Rugged and compact
- New muting function to increase both productivity and safety
- All models designed for global use. PNP/NPN selection by DIP switch
- Conforming to major international standards including Chinese standard GB/T 4584



## System Configuration

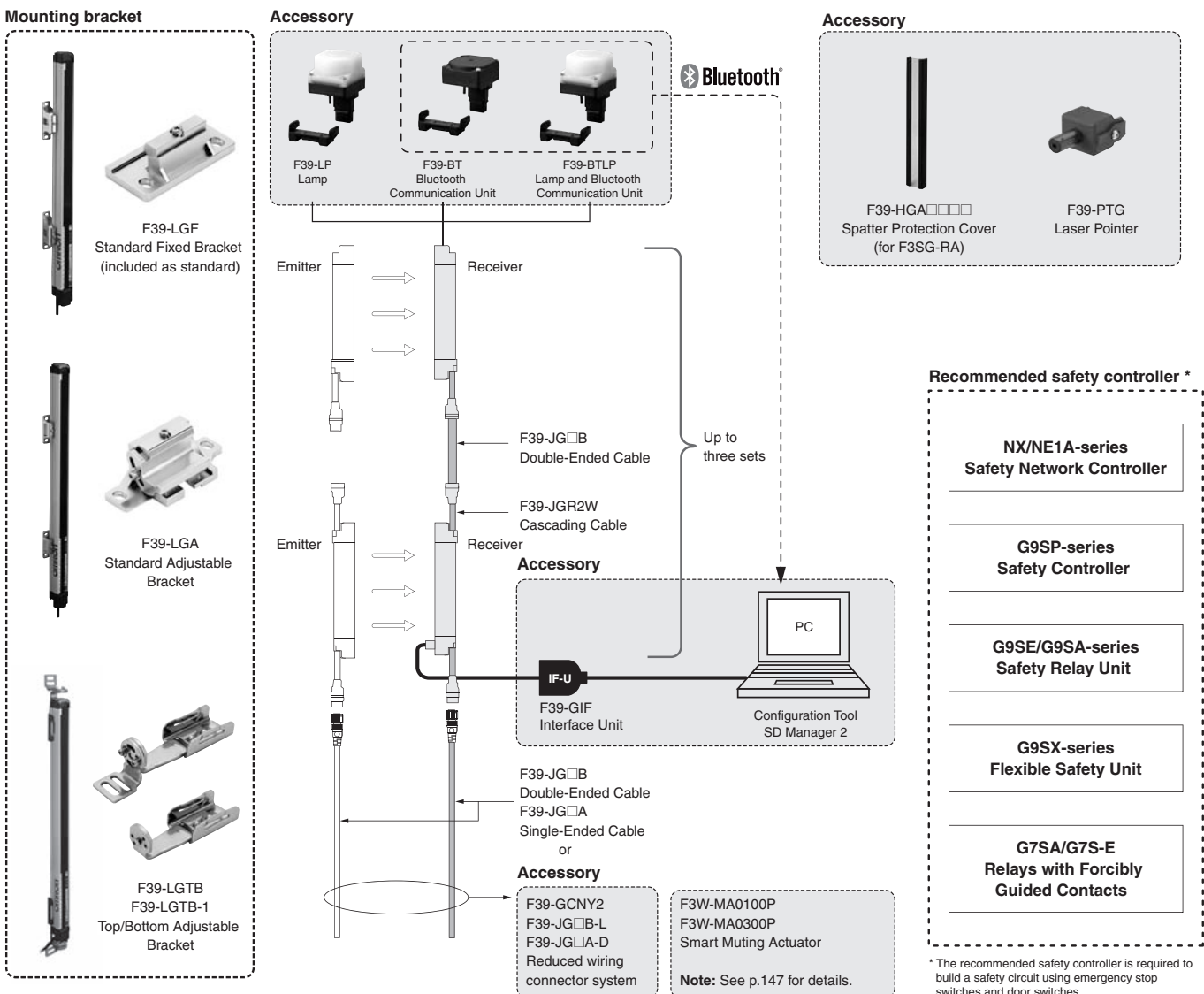

## Ordering Information

### Main Units

#### Safety Light Curtain

##### Finger protection

Number of beams	Protective height (mm)	Model
15	160	F3SG-4RA0160-14
23	240	F3SG-4RA0240-14
31	320	F3SG-4RA0320-14
39	400	F3SG-4RA0400-14
47	480	F3SG-4RA0480-14
55	560	F3SG-4RA0560-14
63	640	F3SG-4RA0640-14
71	720	F3SG-4RA0720-14
79	800	F3SG-4RA0800-14
87	880	F3SG-4RA0880-14
95	960	F3SG-4RA0960-14
103	1040	F3SG-4RA1040-14
111	1120	F3SG-4RA1120-14
119	1200	F3SG-4RA1200-14
127	1280	F3SG-4RA1280-14
135	1360	F3SG-4RA1360-14
143	1440	F3SG-4RA1440-14
151	1520	F3SG-4RA1520-14
159	1600	F3SG-4RA1600-14
167	1680	F3SG-4RA1680-14
175	1760	F3SG-4RA1760-14
183	1840	F3SG-4RA1840-14
191	1920	F3SG-4RA1920-14
199	2000	F3SG-4RA2000-14
207	2080	F3SG-4RA2080-14



##### Hand and arm protection

Number of beams	Protective height (mm)	Model
8	190	F3SG-4RA0190-30
12	270	F3SG-4RA0270-30
16	350	F3SG-4RA0350-30
20	430	F3SG-4RA0430-30
24	510	F3SG-4RA0510-30
28	590	F3SG-4RA0590-30
32	670	F3SG-4RA0670-30
36	750	F3SG-4RA0750-30
40	830	F3SG-4RA0830-30
44	910	F3SG-4RA0910-30
48	990	F3SG-4RA0990-30
52	1070	F3SG-4RA1070-30
56	1150	F3SG-4RA1150-30
60	1230	F3SG-4RA1230-30
64	1310	F3SG-4RA1310-30
68	1390	F3SG-4RA1390-30
72	1470	F3SG-4RA1470-30
76	1550	F3SG-4RA1550-30
80	1630	F3SG-4RA1630-30
84	1710	F3SG-4RA1710-30
88	1790	F3SG-4RA1790-30
92	1870	F3SG-4RA1870-30
96	1950	F3SG-4RA1950-30
100	2030	F3SG-4RA2030-30
104	2110	F3SG-4RA2110-30
108	2190	F3SG-4RA2190-30
112	2270	F3SG-4RA2270-30
116	2350	F3SG-4RA2350-30
120	2430	F3SG-4RA2430-30
124	2510	F3SG-4RA2510-30

## Accessories (Sold separately)

### Safety light curtain connecting cable

#### Single-Ended Cable \*

Appearance	Type	Cable length	Specifications	Model																							
	For emitter M12 connector (5-pin), 5 wires Color: Gray	3 m	Connected to Power Cable or Double-Ended Cable  Female <table border="1"> <tr><td>1</td><td>+24 VDC</td><td>Brown</td></tr> <tr><td>2</td><td>TEST</td><td>Black</td></tr> <tr><td>3</td><td>0 VDC</td><td>Blue</td></tr> <tr><td>4</td><td>Not used</td><td>White</td></tr> <tr><td>5</td><td>Not used</td><td>Yellow</td></tr> </table>	1	+24 VDC	Brown	2	TEST	Black	3	0 VDC	Blue	4	Not used	White	5	Not used	Yellow	F39-JG3A-L								
		1		+24 VDC	Brown																						
		2		TEST	Black																						
		3		0 VDC	Blue																						
		4		Not used	White																						
	5	Not used	Yellow																								
	7 m	F39-JG7A-L																									
	10 m	F39-JG10A-L																									
	15 m	F39-JG15A-L																									
	20 m	F39-JG20A-L																									
For receiver M12 connector (8-pin), 8 wires Color: Black	3 m	Connected to Power Cable or Double-Ended Cable  Female <table border="1"> <tr><td>1</td><td>RESET</td><td>Yellow</td></tr> <tr><td>2</td><td>+24 VDC</td><td>Brown</td></tr> <tr><td>3</td><td>MUTE A</td><td>Gray</td></tr> <tr><td>4</td><td>MUTE B</td><td>Pink</td></tr> <tr><td>5</td><td>OSSD 1</td><td>Black</td></tr> <tr><td>6</td><td>OSSD 2</td><td>White</td></tr> <tr><td>7</td><td>0 VDC</td><td>Blue</td></tr> <tr><td>8</td><td>AUX</td><td>Red</td></tr> </table>	1	RESET	Yellow	2	+24 VDC	Brown	3	MUTE A	Gray	4	MUTE B	Pink	5	OSSD 1	Black	6	OSSD 2	White	7	0 VDC	Blue	8	AUX	Red	F39-JG3A-D
	1		RESET	Yellow																							
	2		+24 VDC	Brown																							
	3		MUTE A	Gray																							
	4		MUTE B	Pink																							
5	OSSD 1	Black																									
6	OSSD 2	White																									
7	0 VDC	Blue																									
8	AUX	Red																									
7 m	F39-JG7A-D																										
10 m	F39-JG10A-D																										
15 m	F39-JG15A-D																										
20 m	F39-JG20A-D																										





\* A set of two Single-Ended Cables (one for emitter and one for receiver) is also available.

Model: Model number without the -L/-D at the end (F39-JG□A)

**Note:** To extend the cable length to more than 20 m, add the F39-JG□B Double-Ended Cable.

#### Double-Ended Cable \*

#### For cable extension and simple wiring

Appearance	Type	Cable length	Specifications	Model																
	For emitter M12 connector (5-pin) on both ends Color: Gray	0.5 m	Connected to Power Cable or Double-Ended Cable  Female Connected to Single-Ended Cable, or Double-Ended Cable  Male <table border="1"> <tr><td>1</td><td>Brown</td></tr> <tr><td>2</td><td>Black</td></tr> <tr><td>3</td><td>Blue</td></tr> <tr><td>4</td><td>White</td></tr> <tr><td>5</td><td>Yellow</td></tr> </table>	1	Brown	2	Black	3	Blue	4	White	5	Yellow	F39-JGR5B-L						
		1		Brown																
		2		Black																
		3		Blue																
		4		White																
		5		Yellow																
		1 m		F39-JG1B-L																
		3 m		F39-JG3B-L																
		5 m		F39-JG5B-L																
		7 m		F39-JG7B-L																
10 m	F39-JG10B-L																			
15 m	F39-JG15B-L																			
20 m	F39-JG20B-L																			
	For receiver M12 connector (8-pin) on both ends Color: Black	0.5 m	Connected to Power Cable or Double-Ended Cable  Female Connected to Single-Ended Cable, or Double-Ended Cable  Male <table border="1"> <tr><td>1</td><td>Yellow</td></tr> <tr><td>2</td><td>Brown</td></tr> <tr><td>3</td><td>Gray</td></tr> <tr><td>4</td><td>Pink</td></tr> <tr><td>5</td><td>Black</td></tr> <tr><td>6</td><td>White</td></tr> <tr><td>7</td><td>Blue</td></tr> <tr><td>8</td><td>Red</td></tr> </table>	1	Yellow	2	Brown	3	Gray	4	Pink	5	Black	6	White	7	Blue	8	Red	F39-JGR5B-D
		1		Yellow																
		2		Brown																
		3		Gray																
		4		Pink																
		5		Black																
		6		White																
		7		Blue																
		8		Red																
		1 m		F39-JG1B-D																
3 m	F39-JG3B-D																			
5 m	F39-JG5B-D																			
7 m	F39-JG7B-D																			
10 m	F39-JG10B-D																			
15 m	F39-JG15B-D																			
20 m	F39-JG20B-D																			

\* A set of two Double-Ended Cables (one for emitter and one for receiver) is also available.

Model: Model number without the -L/-D at the end (F39-JG□B)

**Note:** To extend the cable length to more than 20 m, add the F39-JG□B Double-Ended Cable to the F39-JG□A Single-Ended Cable.

To extend the cable length to more than 40 m, add several Double-Ended Cables to the Single-Ended Cable.

Example: To extend the cable length to 50 m, connect two F39-JG20B (20 m) cables and one F39-JG10A (10 m) cable.

#### <Connection example>

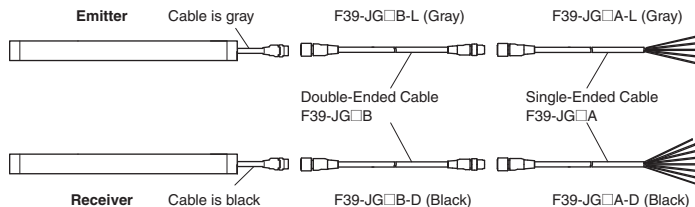

**Y-Joint Plug/Socket Connector for F3SG-4RA□□□□-14/-4RA□□□□-30**  
**For reduced wiring**

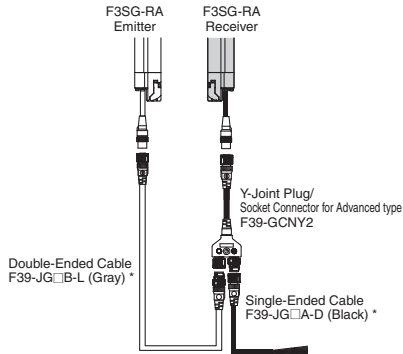
Appearance	Type	Cable length	Specifications	Model
	M12 connectors. Used for reduced wiring.	0.5 m		<b>F39-GCNY2</b>

\* Order the cable for emitter (end of model: -L) and the cable for receiver (end of model: -D).

**Cascading Cable (2 cables per set, for emitter and receiver)**

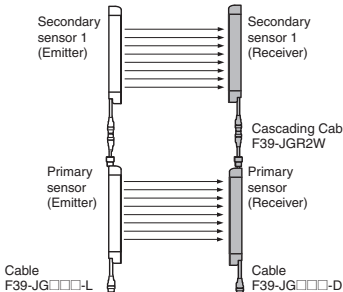

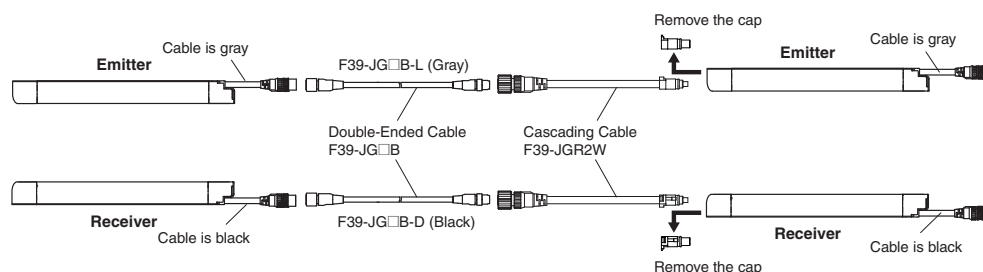

Appearance	Type	Cable length	Specifications	Model
	Emitter cable: Cap (5-pin), M12 connector (5-pin) Receiver cable: Cap (8-pin), M12 connector (8-pin)	0.2 m		<b>F39-JGR2W</b>

**Note:** The Double-Ended Cable (up to 10 m: F39-JG10B) can be added to extend the cable length between the series-connected sensors.  
 Cable length between sensors: 10 m max. (not including cascading cable (F39-JGR2W) and power cable)

**<Connection example>**



## Sensor Mounting Brackets

Appearance	Specification	Application	Model
	Standard Fixed Bracket	Bracket to mount the F3SG-R. Side mounting and backside mounting possible. (This is included as a standard accessory with the product. It comes as a set of two Brackets. Refer to note *1 for the number of sets provided with each model.)	<b>F39-LGF</b>
	Standard Adjustable Bracket	Bracket to mount the F3SG-R. Beam alignment after mounting possible. The angle adjustment range is $\pm 15^\circ$ . Side mounting and backside mounting possible. (Sold separately as a set of two Brackets. Refer to note *1 for the number of sets required for each model.)	<b>F39-LGA</b>
	Top/Bottom Adjustable Bracket *2	Bracket to mount the F3SG-R. Use this bracket at the top and bottom positions of the F3SG-R. Beam alignment after mounting possible. The angle adjustment range is $\pm 22.5^\circ$ . Side mounting and backside mounting possible. (Sold separately. 4 brackets per set.)	<b>F39-LGTB</b>
	Top/Bottom Adjustable Bracket *2 (For user-made mounting part)	Top/Bottom Adjustable Bracket without a bracket to mount to the wall. Use the user's own wall mounting part to suit the machine. (Sold separately. 4 brackets per set.)	<b>F39-LGTB-1</b>

\*1. [for F3SG-4RA□□□□-14]

- Protective height of 0160 to 1200: 2 sets, Protective height of 1280 to 2080: 3 sets

[for F3SG-4RA□□□□-30]

- Protective height of 0190 to 1230: 2 sets, Protective height of 1310 to 2270: 3 sets, Protective height of 2350 to 2510: 4 sets

\*2. Top/Bottom Adjustable Bracket cannot be used with the Standard Fixed Bracket. Use with the Standard Adjustable Bracket.

Using Top/Bottom Adjustable Brackets with Standard Adjustable Brackets

F3SG-4RA□□□□-14: Protective height of 1040 or less: The Standard Adjustable Bracket is not required. Please purchase 1 set of Top/Bottom Adjustable Brackets (F39-LGTB(-1)).

Protective height of 1120 to 1920: Please purchase 1 set of Top/Bottom Adjustable Brackets (F39-LGTB(-1)) and 1 set of Standard Adjustable Brackets (F39-LGA).



Protective height of 2000 to 2080: Please purchase 1 set of Top/Bottom Adjustable Brackets (F39-LGTB(-1)) and 2 sets of Standard Adjustable Brackets (F39-LGA).

F3SG-4RA□□□□-30: Protective height of 1070 or less: The Standard Adjustable Bracket is not required. Please purchase 1 set of Top/Bottom Adjustable Brackets (F39-LGTB(-1)).

Protective height of 1150 to 1950: Please purchase 1 set of Top/Bottom Adjustable Brackets (F39-LGTB(-1)) and 1 set of Standard Adjustable Brackets (F39-LGA).

Protective height of 2030 to 2510: Please purchase 1 set of Top/Bottom Adjustable Brackets (F39-LGTB(-1)) and 2 sets of Standard Adjustable Brackets (F39-LGA).

## Interface units and configuration tool SD Manager 2

Appearance	Type	Specifications	Model
	SD Manager 2	The Configuration Tool SD Manager 2 is available to download from our website at <a href="http://www.ia.omron.com/f3sg-r_tool">http://www.ia.omron.com/f3sg-r_tool</a> . To change the settings of the F3SG-RA using SD Manager 2, it is necessary to set the receiver's two DIP switches No. 8 to ON.	-
	Interface Unit	F39-GIF interface unit to connect the F3SG-RA receiver to a USB port of the PC  Accessories: 0.3-m Dedicated Cable 1 (1), 2-m Dedicated Cable 2 (1), Instruction Manual	F39-GIF
	Bluetooth Communication Unit	F39-BT bluetooth unit to enable bluetooth on the F3SG-RA  IP67 rated when mated.	F39-BT

## Lamp

Appearance	Type	Specifications	Model
	Lamp	The lamp can be connected to a receiver and turned ON based on the operation of F3SG-RA/RR.	F39-LP
	Lamp and Bluetooth Communication Unit	The lamp can indicate red, orange, and green colors, to which three different states can be assigned.  IP67 rated when mated.	F39-BTLP

## End Cap

Appearance	Specifications	Model
	Housing color: Black For both emitter and receiver (Attached to the F3SG-RA. The End Cap can be purchased if lost.)  IP67 rated when mated.	F39-CNM

## Laser Pointer for F3SG-R

Appearance	Specifications	Model
	The laser pointer is attached on the optical surface of the F3SG-R to help coarse adjustment of beams.	F39-PTG

# F3SG-RA

## Spatter Protection Cover (2 covers per set, one for emitter and one for receiver)

Spatter Protection Covers include mounting brackets.

For Safety Light Curtain models of the protective height of 2,000 mm or longer, use two Spatter Protection Covers of different lengths.

Appearance	Safety Light Curtain Model		Model
	Finger protection	Hand and arm protection	
	F3SG-4RA0160-14	F3SG-4RA0190-30	F39-HGA0200
	F3SG-4RA0240-14	F3SG-4RA0270-30	F39-HGA0280
	F3SG-4RA0320-14	F3SG-4RA0350-30	F39-HGA0360
	F3SG-4RA0400-14	F3SG-4RA0430-30	F39-HGA0440
	F3SG-4RA0480-14	F3SG-4RA0510-30	F39-HGA0520
	F3SG-4RA0560-14	F3SG-4RA0590-30	F39-HGA0600
	F3SG-4RA0640-14	F3SG-4RA0670-30	F39-HGA0680
	F3SG-4RA0720-14	F3SG-4RA0750-30	F39-HGA0760
	F3SG-4RA0800-14	F3SG-4RA0830-30	F39-HGA0840
	F3SG-4RA0880-14	F3SG-4RA0910-30	F39-HGA0920
	F3SG-4RA0960-14	F3SG-4RA0990-30	F39-HGA1000
	F3SG-4RA1040-14	F3SG-4RA1070-30	F39-HGA1080
	F3SG-4RA1120-14	F3SG-4RA1150-30	F39-HGA1160
	F3SG-4RA1200-14	F3SG-4RA1230-30	F39-HGA1240
	F3SG-4RA1280-14	F3SG-4RA1310-30	F39-HGA1320
	F3SG-4RA1360-14	F3SG-4RA1390-30	F39-HGA1400
	F3SG-4RA1440-14	F3SG-4RA1470-30	F39-HGA1480
	F3SG-4RA1520-14	F3SG-4RA1550-30	F39-HGA1560
	F3SG-4RA1600-14	F3SG-4RA1630-30	F39-HGA1640
	F3SG-4RA1680-14	F3SG-4RA1710-30	F39-HGA1720
	F3SG-4RA1760-14	F3SG-4RA1790-30	F39-HGA1800
	F3SG-4RA1840-14	F3SG-4RA1870-30	F39-HGA1880
	F3SG-4RA1920-14	F3SG-4RA1950-30	F39-HGA1960
	F3SG-4RA2000-14	F3SG-4RA2030-30	F39-HGA1480
			F39-HGA0550
	F3SG-4RA2080-14	F3SG-4RA2110-30	F39-HGA1560
			F39-HGA0550
-	F3SG-4RA2190-30	F39-HGA1640	
		F39-HGA0550	
-	F3SG-4RA2270-30	F39-HGA1720	
		F39-HGA0550	
-	F3SG-4RA2350-30	F39-HGA1800	
		F39-HGA0550	
-	F3SG-4RA2430-30	F39-HGA1880	
		F39-HGA0550	
-	F3SG-4RA2510-30	F39-HGA1960	
		F39-HGA0550	

**Note:** 1. The operating range of the Safety Light Curtain attached with the product is 10% shorter than the rating.

2. The product extends over the DIP Switch cover of the Safety Light Curtain. Be sure to use the product only after all required settings are made to the DIP Switch.

### Test Rod

Diameter	Model
14 mm dia.	F39-TRD14
30 mm dia.	F39-TRD30

# Ratings and Specifications

## Main unit

The □□□□ in the model names indicate the protective heights in millimeters.

		F3SG-4RA□□□□-14 F3SG-2RA□□□□-14	F3SG-4RA□□□□-30 F3SG-2RA□□□□-30	
Type of ESPE (IEC 61496-1)	Type 4	F3SG-4RA□□□□-14/-30		
	Type 2	F3SG-2RA□□□□-14/-30		
Performance	Object Resolution (Detection Capability)	Opaque objects 14-mm dia.		
	Beam Gap	10 mm	20 mm	
	Number of Beams	15 to 207	8 to 124	
	Lens Size	5.2 × 3.4 (W × H) mm		
	Protective Height	160 to 2080 mm (6.3 to 81.9 inch)		
	Operating Range	Long	0.3 to 10.0 m (1 to 32 ft.)	0.3 to 20.0 m (1 to 65 ft.)
		Short	0.3 to 3.0 m (1 to 10 ft.)	0.3 to 7.0 m (1 to 23 ft.)
	Response Time	ON to OFF	Normal mode: 8 to 18 ms max. *1 Slow mode: 16 to 36 ms max. *1 *2	
		OFF to ON	40 to 90 ms max. *1	
		*1. Response time when used in one segment system or in cascaded connection. Refer to page 25 for the one segment system. Refer to <i>Safety Light Curtain F3SG-R Series User's Manual (ManNo.: Z352)</i> for cascaded connection. *2. Selectable by Configuration Tool.		
	Effective Aperture Angle (EAA) (IEC 61496-2)	Type 4	±2.5° max., emitter and receiver at operating range of 3 m or greater	
		Type 2	±5.0° max., emitter and receiver at operating range of 3 m or greater	
Light Source	Infrared LEDs, Wavelength: 870 nm			
Startup Waiting Time	2 s max.			
Power Supply Voltage (Vs)	SELV/PELV 24 VDC±20% (ripple p-p 10% max.)			
Current Consumption	Refer to page 25.			
Safety Outputs (OSSD)	Two PNP or NPN transistor outputs (PNP or NPN is selectable by DIP Switch.) Load current of 300 mA max., Residual voltage of 2 V max. (except for voltage drop due to cable extension), Capacitive load of 1 µF max., Inductive load of 2.2 H max. *1 Leakage current of 1 mA max. (PNP), 2 mA max. (NPN) *2  *1. The load inductance is the maximum value when the safety output frequently repeats ON and OFF. When you use the safety output at 4 Hz or less, the usable load inductance becomes larger. *2. These values must be taken into consideration when connecting elements including a capacitive load such as a capacitor.			
Auxiliary Output	One PNP or NPN transistor output (PNP or NPN is selectable by DIP Switch.) Load current of 100 mA max., Residual voltage of 2 V max.			
Output Operation Mode	Safety Output	Light-ON (Safety output is enabled when the receiver receives an emitting signal.)		
	Auxiliary Output	Safety output (Inverted signal output:Enable) (default) (Configurable by Configuration Tool)		
Input Voltage	RESET (EDM)	PNP ON voltage: Vs-3 V to Vs (short circuit current: approx. 6.5 mA) * OFF voltage: 0 V to 1/2 Vs, or open (short circuit current: approx. 8.0 mA) * NPN ON voltage: 0 to 3 V (short circuit current: approx. 8.0 mA) OFF voltage: 1/2 Vs to Vs, or open (short circuit current: approx. 6.5 mA) *		
		MUTE A/B	PNP ON voltage: Vs-3 V to Vs (short circuit current: approx. 3.0 mA) * OFF voltage: 0 V to 1/2 Vs, or open (short circuit current: approx. 5.0 mA) * NPN ON voltage: 0 to 3 V (short circuit current: approx. 5.0 mA) OFF voltage: 1/2 Vs to Vs, or open (short circuit current: approx. 3.0 mA) *	
	TEST		24 V Active ON voltage: 9 V to Vs (short circuit current: approx. 2.5mA) * OFF voltage: 0 to 3 V, or open (short circuit current: approx. 2.0 mA) 0 V Active ON voltage: 0 to 3 V (short circuit current: approx. 2.0 mA) OFF voltage: 9 V to Vs, or open (short circuit current: approx. 2.5 mA) *	
* The Vs indicates a supply voltage value in your environment.				
Overvoltage Category (IEC 60664-1)	II			
Indicators	Refer to page 27.			
Protective Circuit	Output short protection, Power supply reverse polarity protection			
Insulation Resistance	20 MΩ or higher (500 VDC megger)			
Dielectric Strength	1,000 VAC, 50/60 Hz (1 min)			
Mutual Interference Prevention (Scan Code)	This function prevents mutual interference in up to two F3SG-RA systems.			
Cascade Connection	Number of cascaded segments: 3 max. Total number of beams: 255 max. Cable length between sensors: 10 m max. (not including cascading cable (F39-JGR2W) and power cable)			
Test Function	Self-test (at power-on, and during operation) External test (light emission stop function by test input)			
Safety-Related Functions	Interlock External device monitoring (EDM) Pre-reset Fixed blanking/Floating blanking Reduced resolution Muting/Override Scan code selection PNP/NPN selection Response time adjustment			

			F3SG-4RA□□□□□-14 F3SG-2RA□□□□□-14	F3SG-4RA□□□□□-30 F3SG-2RA□□□□□-30
Environmental	Ambient Temperature	Operating	-10 to 55°C (14 to 131°F) (non-icing)	
		Storage	-25 to 70°C (-13 to 158°F)	
	Ambient Humidity	Operating	35% to 85% (non-condensing)	
		Storage	35% to 95%	
	Ambient Illuminance		Incandescent lamp: 3,000 lx max. on receiver surface Sunlight: 10,000 lx max. on receiver surface	
	Degree of Protection (IEC 60529)		IP65 and IP67	
	Vibration Resistance (IEC 61496-1)		Class 3M4 (IEC TR 60721-4-3) Operation limit: 5 to 150 Hz, Multiple amplitude of 7 mm, Acceleration of 1 G, 10 sweeps each in X, Y, and Z directions (no delay at resonant frequencies)	
	Shock Resistance (IEC 61496-1)		Class 3M4 (IEC TR 60721-4-3) Operation limit: Acceleration of 15 G, Pulse duration of 6 ms, 100 shocks for each in X, Y, and Z directions (600 shocks in total)	
Pollution Degree (IEC 60664-1)		Pollution Degree 3		
Connections	Power cable	Type of Connection	M12 connectors: 5-pin emitter and 8-pin receiver, IP67 rated when mated, Cables prewired to the sensors	
		Number of Wires	Emitter: 5, Receiver: 8	
		Cable Length	0.3 m	
		Cable Diameter	6 mm	
		Minimum Bending Radius	R5 mm	
	Cascading cable	Type of Connection	M12 connectors: 5-pin emitter and 8-pin receiver, IP67 rated when mated	
		Number of Wires	Emitter: 5, Receiver: 8	
		Cable Length	0.2 m	
		Minimum Bending Radius	R5 mm	
	Extension cable - Single-Ended Cable - Double-Ended Cable	Type of Connection	M12 connectors: 5-pin emitter and 8-pin receiver, IP67 rated when mated	
		Number of Wires	Emitter: 5, Receiver: 8	
		Cable Length	Refer to page 18.	
		Minimum Bending Radius	R36 mm	
Extension of Power Cable		100 m max.		
Material	Material	Housing: Aluminum alloy Cap: PBT resin Front window: Acrylic resin Cable: Oil-resistant PVC resin Standard Fixed Bracket (F39-LGF): Zinc alloy FE plate: Stainless steel		
	Weight	Refer to page 25.		
	Included Accessories	Safety Precautions, Quick Installation Manual, Standard Fixed Bracket *, Troubleshooting Guide Sticker, Warning Zone Label * The quantity of Standard Fixed Brackets included varies depending on the protective height. [F3SG-□RA□□□□□-14] - Protective height of 0160 to 1200: 2 sets - Protective height of 1280 to 2080: 3 sets [F3SG-□RA□□□□□-30] - Protective height of 0190 to 1230: 2 sets - Protective height of 1310 to 2270: 3 sets - Protective height of 2350 to 2510: 4 sets		
Conformity	Conforming standards		Refer to page 26.	
	Type of ESPE (IEC 61496-1)		Type 4	
	Performance Level (PL)/Safety category	Type 4	PL e/Category 4 (EN ISO 13849-1:2015)	
		Type 2	PL c/Category 2 (EN ISO 13849-1:2015)	
	PFH <sub>0</sub>		1.1 × 10 <sup>-8</sup> (IEC 61508)	
	Proof test interval T <sub>M</sub>		Every 20 years (IEC 61508)	
	SFF		99% (IEC 61508)	
	HFT		1 (IEC 61508)	
Classification		Type B (IEC 61508-2)		

## Bluetooth Communication Unit

Communication System	Bluetooth Version 3.0
Communication Profile	SPP (Serial Port Profile)
Transmission Distance	Approx. 10 m max. (Output power: Class 2) *

\* It depends on use environment conditions.

## List of Models/Response Time/Current Consumption/Weight

## F3SG-4RA□□□□-14/F3SG-2RA□□□□-14

Model		Number of Beams	Protective Height [mm]	Response Time [ms] *1			Current Consumption [mA]		Weight [kg]	
				ON → OFF *2	OFF (Synchronized) → ON	OFF (Not synchronized) → ON	Emitter	Receiver	Net *3	Gross *4
F3SG-4RA0160-14	F3SG-2RA0160-14	15	160	8	40	140	40	75	0.7	2.0
F3SG-4RA0240-14	F3SG-2RA0240-14	23	240	8	40	140	45	75	0.9	2.3
F3SG-4RA0320-14	F3SG-2RA0320-14	31	320	8	40	140	55	75	1.1	2.6
F3SG-4RA0400-14	F3SG-2RA0400-14	39	400	8	40	140	60	80	1.3	2.9
F3SG-4RA0480-14	F3SG-2RA0480-14	47	480	13	65	165	50	80	1.5	3.2
F3SG-4RA0560-14	F3SG-2RA0560-14	55	560	13	65	165	55	80	1.7	3.5
F3SG-4RA0640-14	F3SG-2RA0640-14	63	640	13	65	165	60	85	1.9	3.9
F3SG-4RA0720-14	F3SG-2RA0720-14	71	720	13	65	165	65	85	2.1	4.2
F3SG-4RA0800-14	F3SG-2RA0800-14	79	800	13	65	165	65	90	2.3	4.5
F3SG-4RA0880-14	F3SG-2RA0880-14	87	880	13	65	165	70	90	2.6	4.8
F3SG-4RA0960-14	F3SG-2RA0960-14	95	960	13	65	165	75	90	2.8	5.1
F3SG-4RA1040-14	F3SG-2RA1040-14	103	1040	13	65	165	80	95	3.0	5.4
F3SG-4RA1120-14	F3SG-2RA1120-14	111	1120	13	65	165	85	95	3.2	5.7
F3SG-4RA1200-14	F3SG-2RA1200-14	119	1200	13	65	165	90	100	3.4	6.0
F3SG-4RA1280-14	F3SG-2RA1280-14	127	1280	13	65	165	95	100	3.6	6.4
F3SG-4RA1360-14	F3SG-2RA1360-14	135	1360	13	65	165	95	105	3.8	6.7
F3SG-4RA1440-14	F3SG-2RA1440-14	143	1440	18	90	190	85	105	4.0	7.0
F3SG-4RA1520-14	F3SG-2RA1520-14	151	1520	18	90	190	90	105	4.2	7.3
F3SG-4RA1600-14	F3SG-2RA1600-14	159	1600	18	90	190	90	110	4.4	7.6
F3SG-4RA1680-14	F3SG-2RA1680-14	167	1680	18	90	190	95	110	4.7	7.9
F3SG-4RA1760-14	F3SG-2RA1760-14	175	1760	18	90	190	100	115	4.9	8.2
F3SG-4RA1840-14	F3SG-2RA1840-14	183	1840	18	90	190	100	115	5.1	8.5
F3SG-4RA1920-14	F3SG-2RA1920-14	191	1920	18	90	190	105	120	5.3	8.8
F3SG-4RA2000-14	F3SG-2RA2000-14	199	2000	18	90	190	105	120	5.5	9.2
F3SG-4RA2080-14	F3SG-2RA2080-14	207	2080	18	90	190	110	125	5.7	9.5

\*1. The maximum speed of movement of a test rod up to which the detection capability is maintained is 2.0 m/s.

\*2. The response times are values when Scan Code is set at Code B. The response times for Code A are 1 ms shorter than these values.

\*3. The net weight is the weight of an emitter and a receiver.

\*4. The gross weight is the weight of an emitter, a receiver, included accessories and a package.

## F3SG-4RA□□□□-30/F3SG-2RA□□□□-30

Model		Number of Beams	Protective Height [mm]	Response Time [ms] *1			Current Consumption [mA]		Weight [kg]	
				ON → OFF *2	OFF (Synchronized) → ON	OFF (Not synchronized) → ON	Emitter	Receiver	Net *3	Gross *4
F3SG-4RA0190-30	F3SG-2RA0190-30	8	190	8	40	140	35	75	0.6	2.1
F3SG-4RA0270-30	F3SG-2RA0270-30	12	270	8	40	140	35	75	0.9	2.4
F3SG-4RA0350-30	F3SG-2RA0350-30	16	350	8	40	140	40	75	1.1	2.7
F3SG-4RA0430-30	F3SG-2RA0430-30	20	430	8	40	140	45	75	1.3	3.0
F3SG-4RA0510-30	F3SG-2RA0510-30	24	510	8	40	140	50	75	1.5	3.3
F3SG-4RA0590-30	F3SG-2RA0590-30	28	590	8	40	140	50	75	1.7	3.6
F3SG-4RA0670-30	F3SG-2RA0670-30	32	670	8	40	140	55	75	1.9	3.9
F3SG-4RA0750-30	F3SG-2RA0750-30	36	750	8	40	140	60	80	2.1	4.2
F3SG-4RA0830-30	F3SG-2RA0830-30	40	830	8	40	140	65	80	2.3	4.5
F3SG-4RA0910-30	F3SG-2RA0910-30	44	910	13	65	165	50	80	2.5	4.8
F3SG-4RA0990-30	F3SG-2RA0990-30	48	990	13	65	165	50	80	2.7	5.1
F3SG-4RA1070-30	F3SG-2RA1070-30	52	1070	13	65	165	55	80	2.9	5.4
F3SG-4RA1150-30	F3SG-2RA1150-30	56	1150	13	65	165	55	85	3.1	5.7
F3SG-4RA1230-30	F3SG-2RA1230-30	60	1230	13	65	165	55	85	3.3	6.0
F3SG-4RA1310-30	F3SG-2RA1310-30	64	1310	13	65	165	60	85	3.5	6.3
F3SG-4RA1390-30	F3SG-2RA1390-30	68	1390	13	65	165	60	85	3.8	6.6
F3SG-4RA1470-30	F3SG-2RA1470-30	72	1470	13	65	165	65	85	4.0	6.9
F3SG-4RA1550-30	F3SG-2RA1550-30	76	1550	13	65	165	65	90	4.2	7.2
F3SG-4RA1630-30	F3SG-2RA1630-30	80	1630	13	65	165	70	90	4.4	7.5
F3SG-4RA1710-30	F3SG-2RA1710-30	84	1710	13	65	165	70	90	4.6	7.8
F3SG-4RA1790-30	F3SG-2RA1790-30	88	1790	13	65	165	70	90	4.8	8.1
F3SG-4RA1870-30	F3SG-2RA1870-30	92	1870	13	65	165	75	90	5.0	8.4
F3SG-4RA1950-30	F3SG-2RA1950-30	96	1950	13	65	165	75	95	5.2	8.7
F3SG-4RA2030-30	F3SG-2RA2030-30	100	2030	13	65	165	80	95	5.4	9.0
F3SG-4RA2110-30	F3SG-2RA2110-30	104	2110	13	65	165	80	95	5.6	9.3
F3SG-4RA2190-30	F3SG-2RA2190-30	108	2190	13	65	165	85	95	5.8	9.6
F3SG-4RA2270-30	F3SG-2RA2270-30	112	2270	13	65	165	85	100	6.0	9.9
F3SG-4RA2350-30	F3SG-2RA2350-30	116	2350	13	65	165	85	100	6.2	10.2
F3SG-4RA2430-30	F3SG-2RA2430-30	120	2430	13	65	165	90	100	6.4	10.5
F3SG-4RA2510-30	F3SG-2RA2510-30	124	2510	13	65	165	90	100	6.7	10.8

\*1. The maximum speed of movement of a test rod up to which the detection capability is maintained is 2.0 m/s.

\*2. The response times are values when Scan Code is set at Code B. The response times for Code A are 1 ms shorter than these values.

\*3. The net weight is the weight of an emitter and a receiver.

\*4. The gross weight is the weight of an emitter, a receiver, included accessories and a package.

## Legislation and Standards

---

1. The F3SG-R does not receive type approval provided by Article 44-2 of the Industrial Safety and Health Act of Japan. When using the F3SG-R in Japan as a "safety system for pressing or shearing machines" prescribed in Article 42 of that law, the machine control system must receive type approval.
2. The F3SG-R is electro-sensitive protective equipment (ESPE) in accordance with European Union (EU) Machinery Directive Index Annex V, Item 2.
3. EU Declaration of Conformity  
OMRON declares that the F3SG-R is in conformity with the requirements of the following EU Directives:  
Machinery Directive 2006/42/EC  
EMC Directive 2014/30/EU
4. Conforming Standards
  - (1) European standards  
EN61496-1 (Type 4 and Type 2 ESPE), EN 61496-2 (Type 4 and Type 2 AOPD), EN61508-1 through -4 (SIL 3 for Type 4 and SIL 1 for Type 2), EN ISO 13849-1:2015 (PL e, Category 4 for Type 4 and PL c, Category 2 for Type 2)
  - (2) International standards  
IEC61496-1 (Type 4 and Type 2 ESPE), IEC61496-2 (Type 4 and Type 2 AOPD), IEC61508-1 through -4 (SIL 3 for Type 4 and SIL 1 for Type 2), ISO 13849-1:2015 (PL e, Category 4 for Type 4 and PL c, Category 2 for Type 2)
  - (3) JIS standards  
JIS B 9704-1 (Type 4 and Type 2 ESPE), JIS B 9704-2 (Type 4 and Type 2 AOPD)
  - (4) North American standards  
UL61496-1 (Type 4 and Type 2 ESPE), UL61496-2 (Type 4 and Type 2 AOPD), UL508, UL1998, CAN/CSA C22.2 No.14, CAN/CSA C22.2 No.0.8
  - (5) Chinese standards  
GB/T 4584 (Specification of active opto-electronic protective devices for presses)
5. Third-Party Certifications
  - (1) TÜV SÜD
    - EC Type-Examination certificate:  
EU Machinery Directive, Type 4 and Type 2 ESPE (EN61496-1), Type 4 and Type 2 AOPD (EN 61496-2)
    - Certificate:  
Type 4 and Type 2 ESPE (EN61496-1), Type 4 and Type 2 AOPD (EN61496-2), EN 61508-1 through -4 (SIL 3 for Type 4 and SIL 1 for Type 2), EN ISO 13849-1:2015 (PL e, Category 4 for Type 4, and PL c, Category 2 for Type 2)
  - (2) UL
    - UL Listing:  
Type 4 and Type 2 ESPE (UL61496-1), Type 4 and Type 2 AOPD (UL61496-2), UL508, UL1998, CAN/CSA C22.2 No.14, CAN/CSA C22.2 No.0.8
  - (3) China National Casting and Forging Machines Quality Supervision and Inspection Center
    - Certificate:  
GB/T 4584 (Specification of active opto-electronic protective devices for presses)
6. Other Standards  
The F3SG-R is designed according to the standards listed below. To make sure that the final system complies with the following standards and regulations, you are asked to design and use it in accordance with all other related standards, laws, and regulations. If you have any questions, consult with specialized organizations such as the body responsible for prescribing and/or enforcing machinery safety regulations in the location where the equipment is to be used.
  - European Standards: EN415-4, EN691-1, EN692, EN693, IEC 62046
  - U.S. Occupational Safety and Health Standards: OSHA 29 CFR 1910.212
  - U.S. Occupational Safety and Health Standards: OSHA 29 CFR 1910.217
  - American National Standards: ANSI B11.1 to B11.19
  - American National Standards: ANSI/RIA R15.06
  - Canadian Standards Association CSA Z142, Z432, Z434
  - SEMI Standards SEMI S2
  - Japan Ministry of Health, Labour and Welfare "Guidelines for Comprehensive Safety Standards of Machinery", Standard Bureau's Notification No. 0731001 dated July 31, 2007.rms and Conditions Agreement
  - Chinese National Standards: GB17120, GB27607

## Indicator

### Emitter

Name of Indicator		Color	Illuminated	Blinking
Test	TEST	Green	–	External Test is being performed
Operating range	LONG	Green	Long range mode is selected	Lockout state due to DIP Switch setting error or Operating range selection setting error
Power	POWER	Green	Power is ON.	Error due to noise
Lockout	LOCKOUT	Red	–	Lockout state due to error in emitter

### Receiver

Name of Indicator		Color	Illuminated	Blinking
Top-beam-state	TOP	Blue	The top beam is unblocked	Muting/Override state, or Lockout state due to Cap error or Other sensor error
PNP/NPN mode	NPN	Green	NPN mode is selected by DIP Switch	–
Response time	SLOW	Green	Response Time Adjustment is enabled	–
Sequence error	SEQ	Yellow	–	Sequence error in Muting or Pre-reset mode
Blanking	BLANK	Green	Blanking, Warning Zone or Reduced Resolution is enabled	Teach-in mode, or Blanking Monitoring error
Configuration	CFG	Green	–	Teach-in mode, zone measurement being performed by Dynamic Muting, or Lockout state due to Parameter error or Cascading Configuration error
Interlock	INT-LK	Yellow	Interlock state	Pre-reset mode
External device monitoring	EDM	Green	RESET input is in ON state *	Lockout state due to EDM error
Internal error	INTERNAL	Red	–	Lockout state due to Internal error, or error due to abnormal power supply or noise
Lockout	LOCKOUT	Red	–	Lockout state due to error in receiver
Stable-state	STB	Green	Incident light level is 170% or higher of ON-threshold	Safety output is instantaneously turned OFF due to ambient light or vibration
ON/OFF	ON/OFF	Green	Safety output is in ON state	–
		Red	Safety output is in OFF state, or the sensor is in Setting state	Lockout state due to Safety Output error, or error due to abnormal power supply or noise
Communication	COM	Green	Synchronization between emitter and receiver is maintained	Lockout state due to Communication error, or error due to abnormal power supply or noise
Bottom-beam-state	BTM	Blue	The bottom beam is unblocked	Muting/Override state, or Lockout state due to DIP Switch setting error

\* The LED is illuminated when the EDM input is in ON state regardless of wiring with EDM used or unused.

### Interface Unit

Main unit	PC/AT compatible machine (computer that runs Microsoft Windows)
Operating system (OS)	Windows 7 (32-bit/64-bit), Windows 8, 8.1 (32-bit/64-bit), Windows 10 (32-bit/64-bit)
Communication port	USB port ×1
Ambient temperature	Operating: -10 to 55°C, Storage: -30 to 70°C (non-icing and non-condensing)
Ambient humidity	Operating: 35% to 85%, Storage: 35% to 95% (non-condensing)

### Lamp

Item	F39-LP
Applicable Sensor	F3SG-□RA/RR Series Safety Light Curtain (Receiver)
LED Light Color	Red/Orange/Green
Power Supply Voltage	24 VDC±20%, ripple p-p 10% max. (shares sensor's power supply)
Current Consumption	25 mA max. (shares sensor's power supply.)
Ambient Temperature	Operating: -10 to 55°C, Storage: -25 to 70°C
Ambient Humidity	Operating: 35% to 85%, Storage: 35% to 95%
Vibration Resistance	10 to 55 Hz, Multiple amplitude of 0.7 mm, 20 sweeps for all 3 axes
Shock Resistance	100 m/s <sup>2</sup> , 1000 shocks for all 3 axes
Degree of Protection	IP65 and IP67 (When attached to F3SG)
Type of Connection	Connectable to F3SG-RA's terminal connector
Material	Lighting element: PC, Other body parts: PBT
Weight	45 g (when packaged)

# F3SG-RA

## Connections (Basic Wiring Diagram)

### Standalone F3SG-RA using PNP Outputs

#### Standard Muting Mode/Exit-Only Muting Mode using PNP Outputs

The following is the example of External Device Monitoring disabled, Auto Reset mode, PNP output and External Test in 24 V Active.

#### DIP Switch settings \*6

	Function	DIP-SW1	DIP-SW2
Receiver	EDM Disabled (factory default setting)	2 <input checked="" type="checkbox"/> ON	2 <input checked="" type="checkbox"/> ON
	Auto Reset (factory default setting)	3 <input checked="" type="checkbox"/> ON	3 <input checked="" type="checkbox"/> ON
		4 <input checked="" type="checkbox"/> ON	4 <input checked="" type="checkbox"/> ON
	PNP (factory default setting)	7 <input checked="" type="checkbox"/> ON	7 <input checked="" type="checkbox"/> ON
Emitter	External Test: 24 V Active (factory default setting)	4 <input checked="" type="checkbox"/> ON	

: Indicates a switch position.

Configure functions with the DIP Switches before wiring.

#### Wiring Example

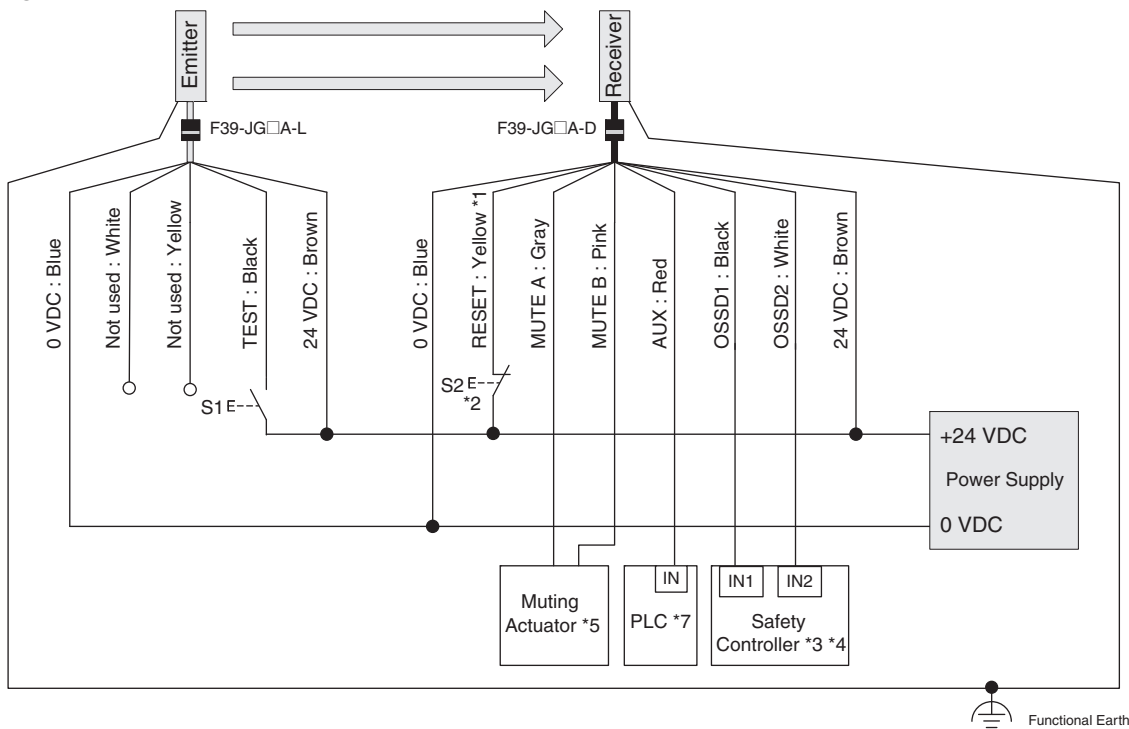

S1: Test Switch (Connect the line to 0 V if this switch is not required)

S2: Lockout Reset Switch, Override Switch or Override Cancel Switch

\*1.Also used as Override input line.

\*2.Make sure to connect an override cancel switch to the Reset line when using the override function. Otherwise the override state may not be released by the override cancel switch, resulting in serious injury.

\*3.Refer to page 30 for more information.

\*4.The safety controller and the F3SG-RA must share the power supply or be connected to the common terminal of the power supply.

\*5.Refer to *Smart Muting Actuator F3W-MA Series User's Manual* for more information.

\*6.The functions are configurable with DIP Switch. Refer to *Safety Light Curtain F3SG-R Series User's Manual* for more information on setting the functions by the DIP Switch.

\*7.When connecting to the PLC, the output mode must be changed with the Configuration Tool according to your application.

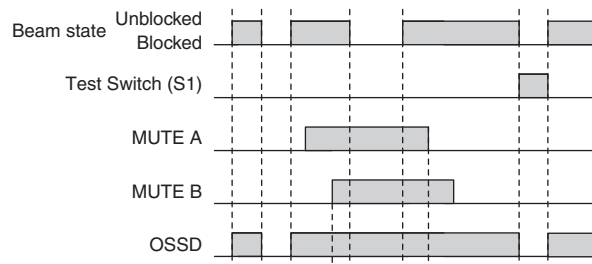

**Note:** Functional earth connection is unnecessary when you use the F3SG-RA in a general industrial environment where noise control or stable power supply is considered. However, when you use the F3SG-RA in an environment where there may be excessive noise from surroundings or stable power supply may be interfered, it is recommended the F3SG-RA be connected to functional earth. The wiring examples in later examples do not indicate functional earth. To use functional earth, wire an earth cable according to the example above. Refer to *Safety Light Curtain F3SG-R Series User's Manual* for more information.

## Standalone F3SG-RA using NPN Outputs

### Standard Muting Mode/Exit-Only Muting Mode using NPN Outputs

The following is the example of External Device Monitoring enabled, Auto Reset mode, NPN output and External Test in 0 V Active.

#### DIP Switch settings \*3

	Function	DIP-SW1	DIP-SW2
Receiver	EDM Enabled	2 <input checked="" type="checkbox"/> ON	2 <input checked="" type="checkbox"/> ON
	Auto Reset (factory default setting)	3 <input checked="" type="checkbox"/> ON	3 <input checked="" type="checkbox"/> ON
		4 <input checked="" type="checkbox"/> ON	4 <input checked="" type="checkbox"/> ON
	NPN	7 <input checked="" type="checkbox"/> ON	7 <input checked="" type="checkbox"/> ON
Emitter	External Test: 0 V Active	4 <input checked="" type="checkbox"/> ON	

: Indicates a switch position.

Configure functions with the DIP Switches before wiring.

#### Wiring Example

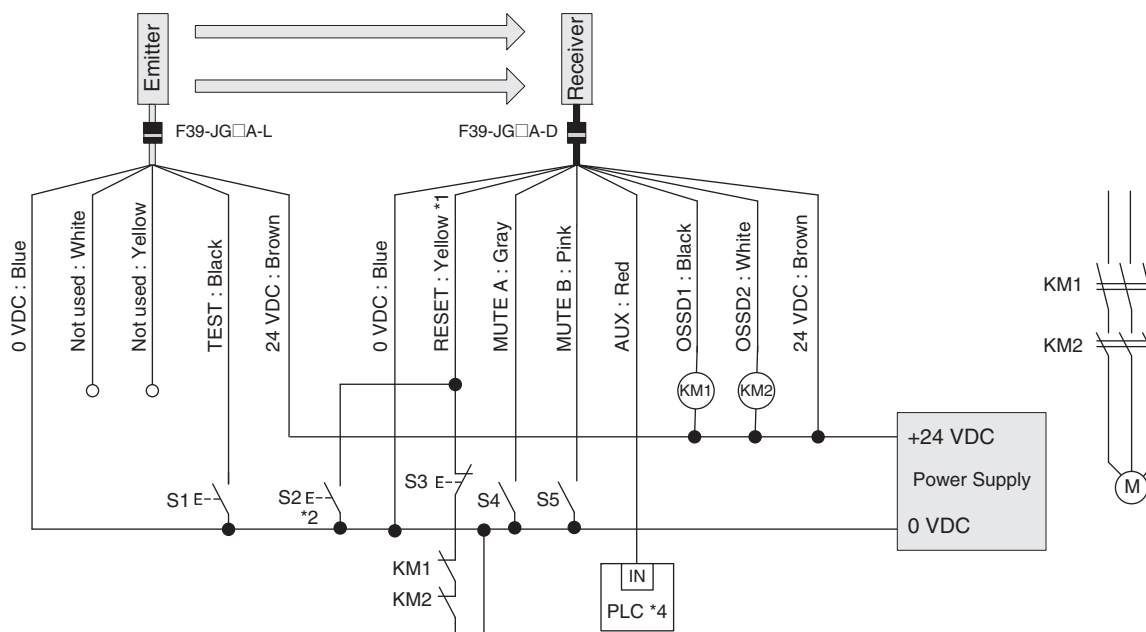

- S1: Test Switch (Connect the line to 24 V if this switch is not required)
- S2: Override Cancel Switch
- S3: Lockout Reset Switch or Override Switch
- S4, S5: Muting sensor
- KM1, KM2: Safety relay with forcibly guided contacts (G7SA) or magnetic contactor
- M: Motor

\*1. Also used as Override input line.

\*2. Make sure to connect an override cancel switch to the Reset line when using the override function. Otherwise the override state may not be released by the override cancel switch, resulting in serious injury.

\*3. The functions are configurable with DIP Switch. Refer to *Safety Light Curtain F3SG-R Series User's Manual* for more information on setting the functions by the DIP Switch.

\*4. When connecting to the PLC, the output mode must be changed with the Configuration Tool according to your application.

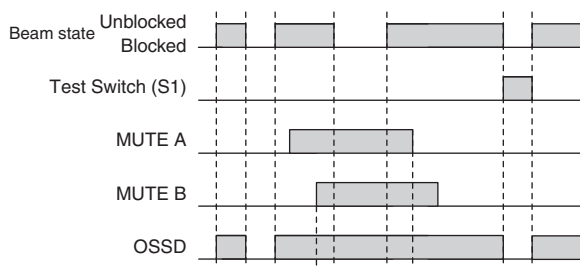

**Note:** For the functional earth connection, refer to page 28.

## Connectable Safety Control Units

The F3SG-RA with PNP output can be connected to the safety control units listed in the table below.

Connectable Safety Control Units (PNP output)		
Safety Relay Units	Flexible Safety Units	Safety Controllers
G9SA-301 G9SA-321-T□ G9SA-501 G9SB-200-B G9SB-200-D G9SB-301-B G9SB-301-D G9SE-201 G9SE-401 G9SE-221-T□	G9SX-AD322-T G9SX-ADA222-T G9SX-BC202 G9SX-GS226-T15	G9SP-N10S G9SP-N10D G9SP-N20S NE0A-SCPU01 NE1A-SCPU01 NE1A-SCPU02 DST1-ID12SL-1 DST1-MD16SL-1 DST1-MRD08SL-1 NX-SIH400 NX-SID800 F3SP-T01

The F3SG-R with NPN output can be connected to the safety control unit listed in the table below.

Connectable Safety Control Units (NPN output)
Safety Relay Units
G9SA-301-P

# Input/Output Circuit

## Entire Circuit Diagram

The entire circuit diagram of the F3SG-RA is shown below.  
The numbers in the circles indicate the connector's pin numbers.

## PNP Output

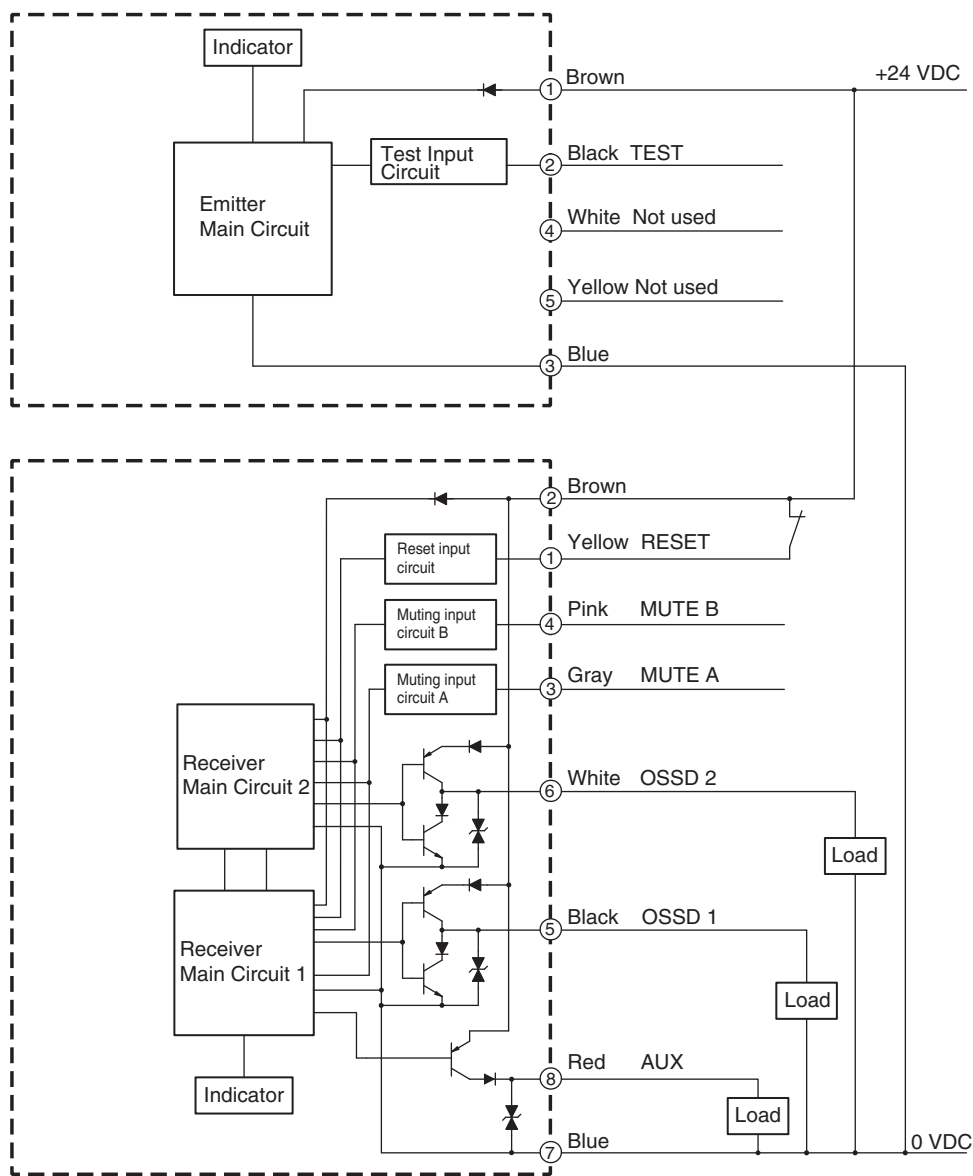

F3SG-RA

## NPN Output

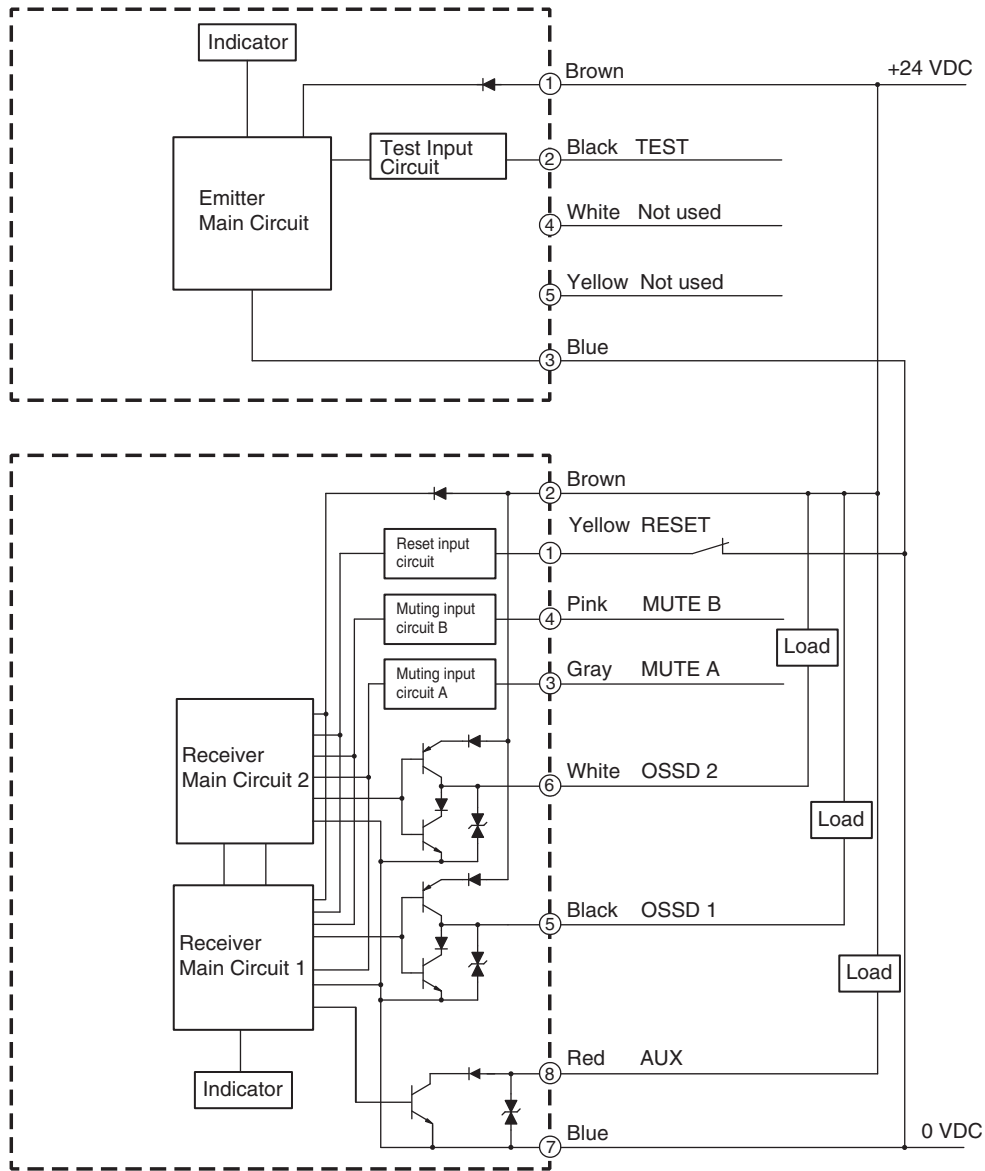

### Input Circuit Diagram by Function

The input circuit diagrams of by function are shown below.

#### TEST

<24 V Active>

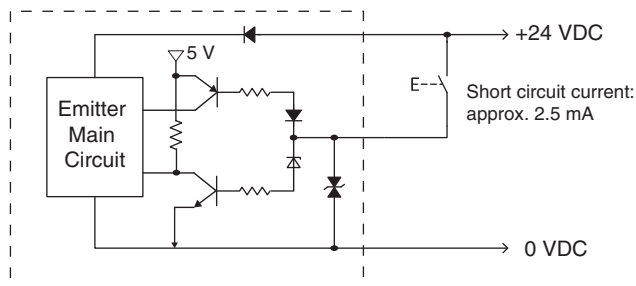

<0 V Active>

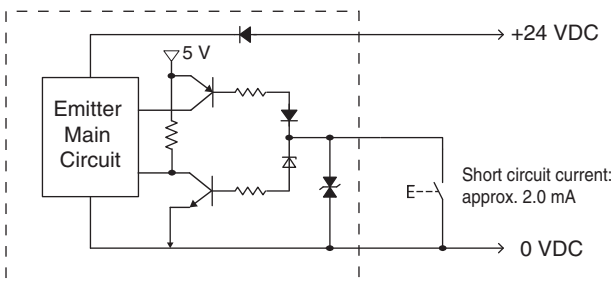

#### RESET/EDM, MUTE A/B

<PNP output>

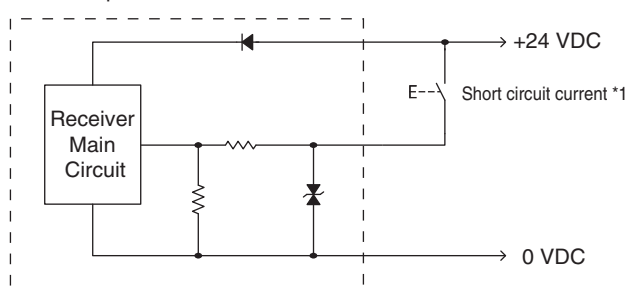

\*1. Short circuit current: approx. 6.5 mA (RESET/EDM), approx. 3.0 mA (MUTE A/B)

<NPN output>

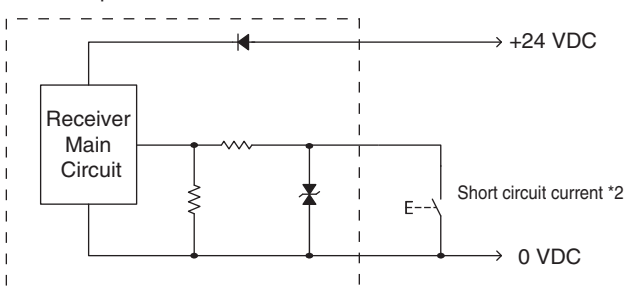

\*2. Short circuit current: approx. 8.0 mA (RESET/EDM), approx. 5.0 mA (MUTE A/B)

### Mounted with Standard Fixed Brackets (F39-LGF)

#### Backside Mounting

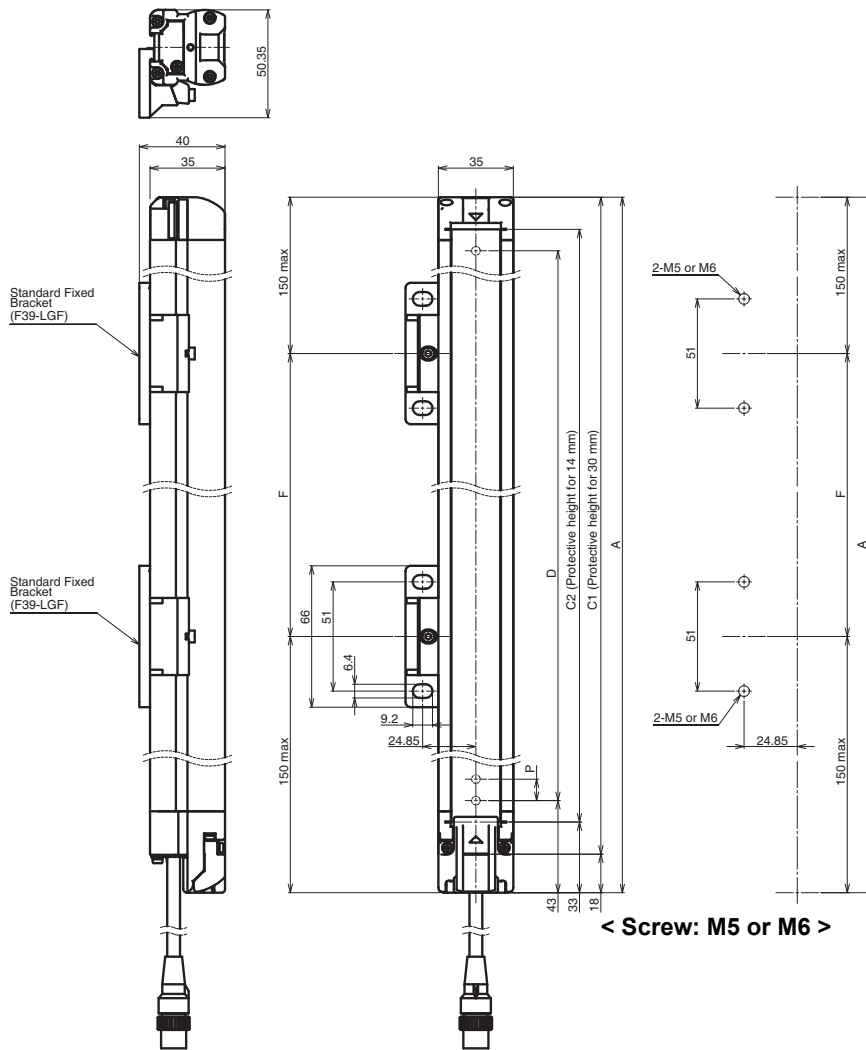

#### F3SG-□RA□□□□-30 Series

Dimension A	C1+18
Dimension C1	4-digit number of the type name (Protective height)
Dimension D	C1-50
Dimension P	20

#### F3SG-□RA□□□□-14 Series

Dimension A	C2+48
Dimension C2	4-digit number of the type name (Protective height)
Dimension D	C2-20
Dimension P	10

Protective height (C1)	Number of Standard Fixed Brackets *1	Dimension F
0190 to 1230	2 *2	1000 mm max.
1310 to 2270	3	1000 mm max.
2350 to 2510	4	1000 mm max.

Protective height (C2)	Number of Standard Fixed Brackets *1	Dimension F
0160 to 1200	2 *2	1000 mm max.
1280 to 2080	3	1000 mm max.

\*1. The number of brackets required to mount either one of emitter and receiver.

\*2. Mounting an emitter or receiver with one bracket is possible for the models of protective height of 0160 to 0270. In this case, locate this bracket at half the Dimension A (or at the center of the sensor length).

Side Mounting

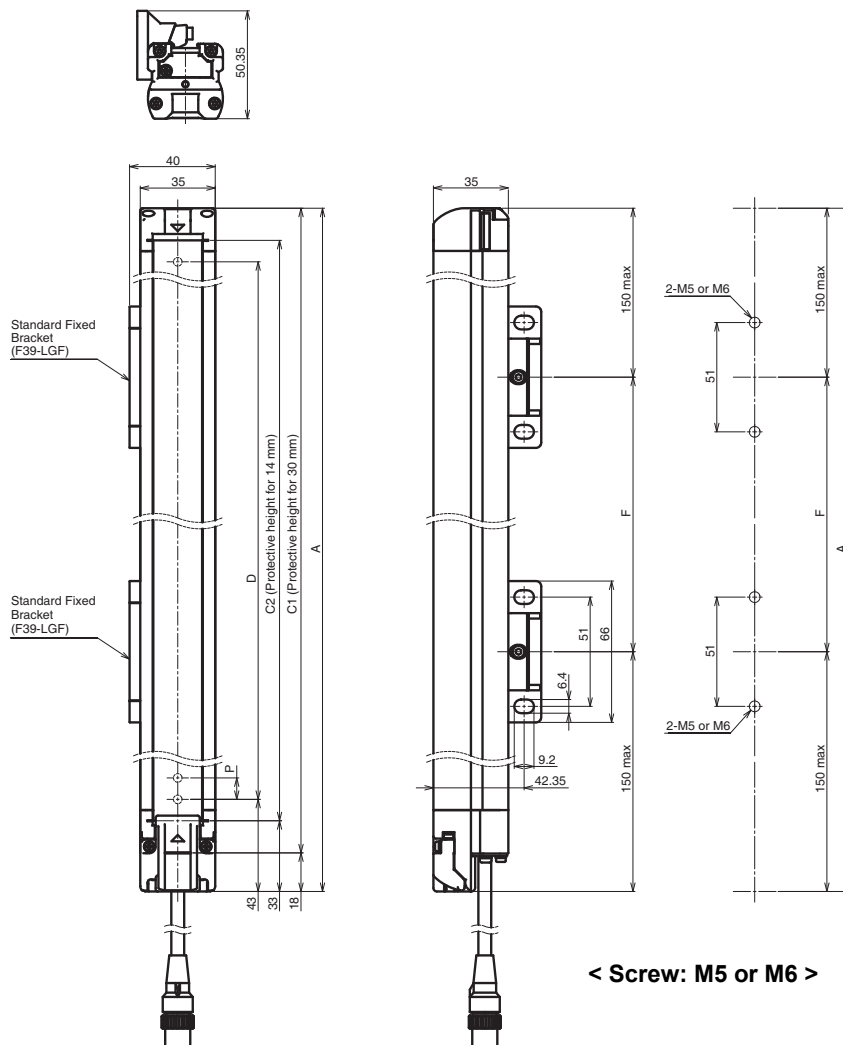

F3SG-□RA□□□□-30 Series

Dimension A	C1+18
Dimension C1	4-digit number of the type name (Protective height)
Dimension D	C1-50
Dimension P	20

Protective height (C1)	Number of Standard Fixed Brackets *1	Dimension F
0190 to 1230	2 *2	1000 mm max.
1310 to 2270	3	1000 mm max.
2350 to 2510	4	1000 mm max.

F3SG-□RA□□□□-14 Series

Dimension A	C2+48
Dimension C2	4-digit number of the type name (Protective height)
Dimension D	C2-20
Dimension P	10

Protective height (C2)	Number of Standard Fixed Brackets *1	Dimension F
0160 to 1200	2 *2	1000 mm max.
1280 to 2080	3	1000 mm max.

\*1. The number of brackets required to mount either one of emitter and receiver.

\*2. Mounting an emitter or receiver with one bracket is possible for the models of protective height of 0160 to 0270. In this case, locate this bracket at half the Dimension A (or at the center of the sensor length).

## Mounted with Standard Adjustable Brackets (F39-LGA) Backside Mounting

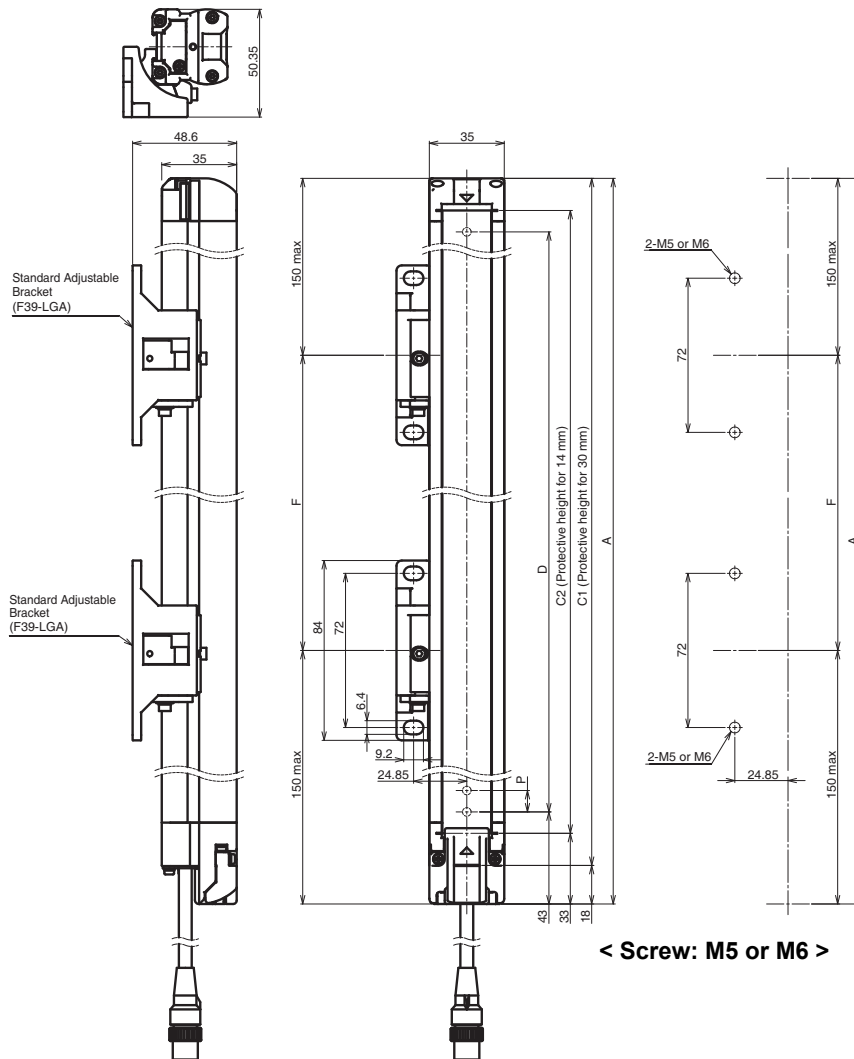

### F3SG-□RA□□□□-30 Series

Dimension A	C1+18
Dimension C1	4-digit number of the type name (Protective height)
Dimension D	C1-50
Dimension P	20

### F3SG-□RA□□□□-14 Series

Dimension A	C2+48
Dimension C2	4-digit number of the type name (Protective height)
Dimension D	C2-20
Dimension P	10

Protective height (C1)	Number of Standard Adjustable Brackets *1	Dimension F
0190 to 1230	2 *2	1000 mm max.
1310 to 2270	3	1000 mm max.
2350 to 2510	4	1000 mm max.

Protective height (C2)	Number of Standard Adjustable Brackets *1	Dimension F
0160 to 1200	2 *2	1000 mm max.
1280 to 2080	3	1000 mm max.

\*1. The number of brackets required to mount either one of emitter and receiver.

\*2. Mounting an emitter or receiver with one bracket is possible for the models of protective height of 0160 to 0270. In this case, locate this bracket at half the Dimension A (or at the center of the sensor length).

Side Mounting

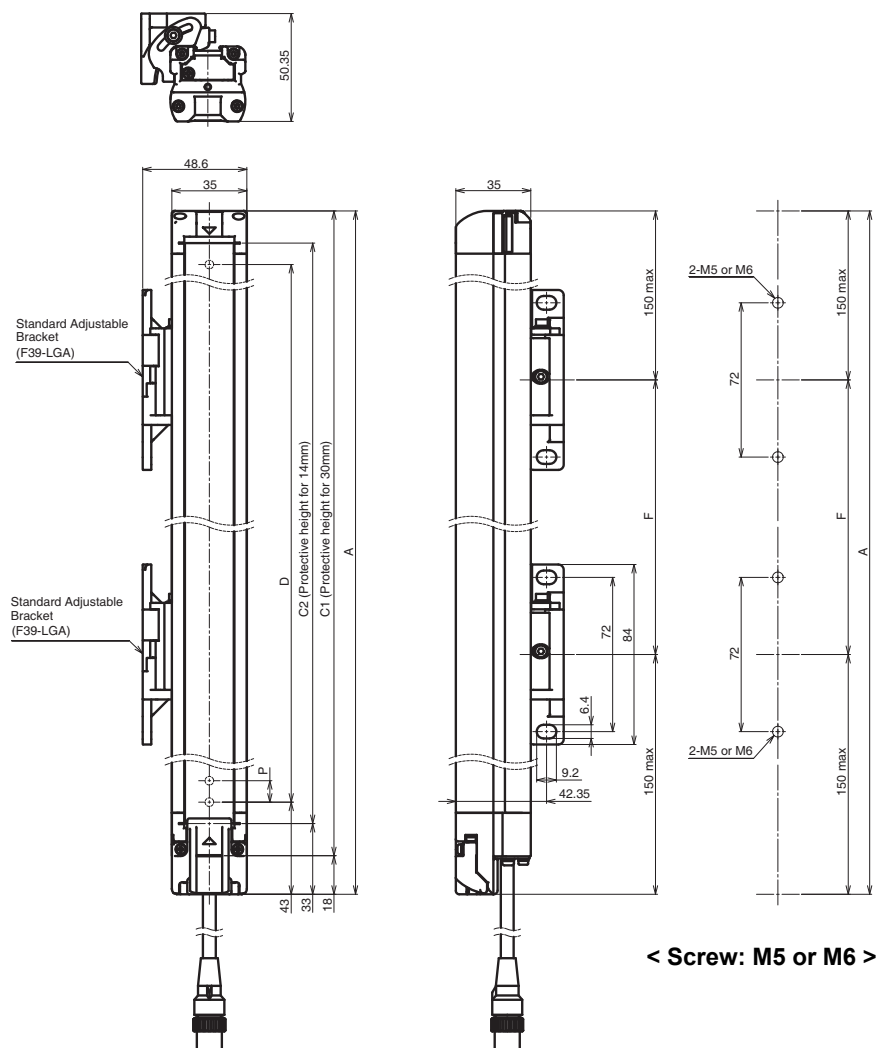

F3SG-□RA□□□□-30 Series

Dimension A	C1+18
Dimension C1	4-digit number of the type name (Protective height)
Dimension D	C1-50
Dimension P	20

Protective height (C1)	Number of Standard Adjustable Brackets *1	Dimension F
0190 to 1230	2 *2	1000 mm max.
1310 to 2270	3	1000 mm max.
2350 to 2510	4	1000 mm max.

F3SG-□RA□□□□-14 Series

Dimension A	C2+48
Dimension C2	4-digit number of the type name (Protective height)
Dimension D	C2-20
Dimension P	10

Protective height (C2)	Number of Standard Adjustable Brackets *1	Dimension F
0160 to 1200	2 *2	1000 mm max.
1280 to 2080	3	1000 mm max.

\*1. The number of brackets required to mount either one of emitter and receiver.

\*2. Mounting an emitter or receiver with one bracket is possible for the models of protective height of 0160 to 0270. In this case, locate this bracket at half the Dimension A (or at the center of the sensor length).

# F3SG-RA

## Mounted with Top/Bottom Adjustable Brackets (F39-LGTB) and Standard Adjustable Brackets (F39-LGA)

Dimensions when using the F3SG-RA Series except the F3SG-4RA0190-30 and F3SG-4RA0160-14

Refer to *Safety Light Curtain F3SG-R Series User's Manual* for the dimensions when using the F3SG-4RA0190-30 and F3SG-4RA0160-14.

### Backside Mounting

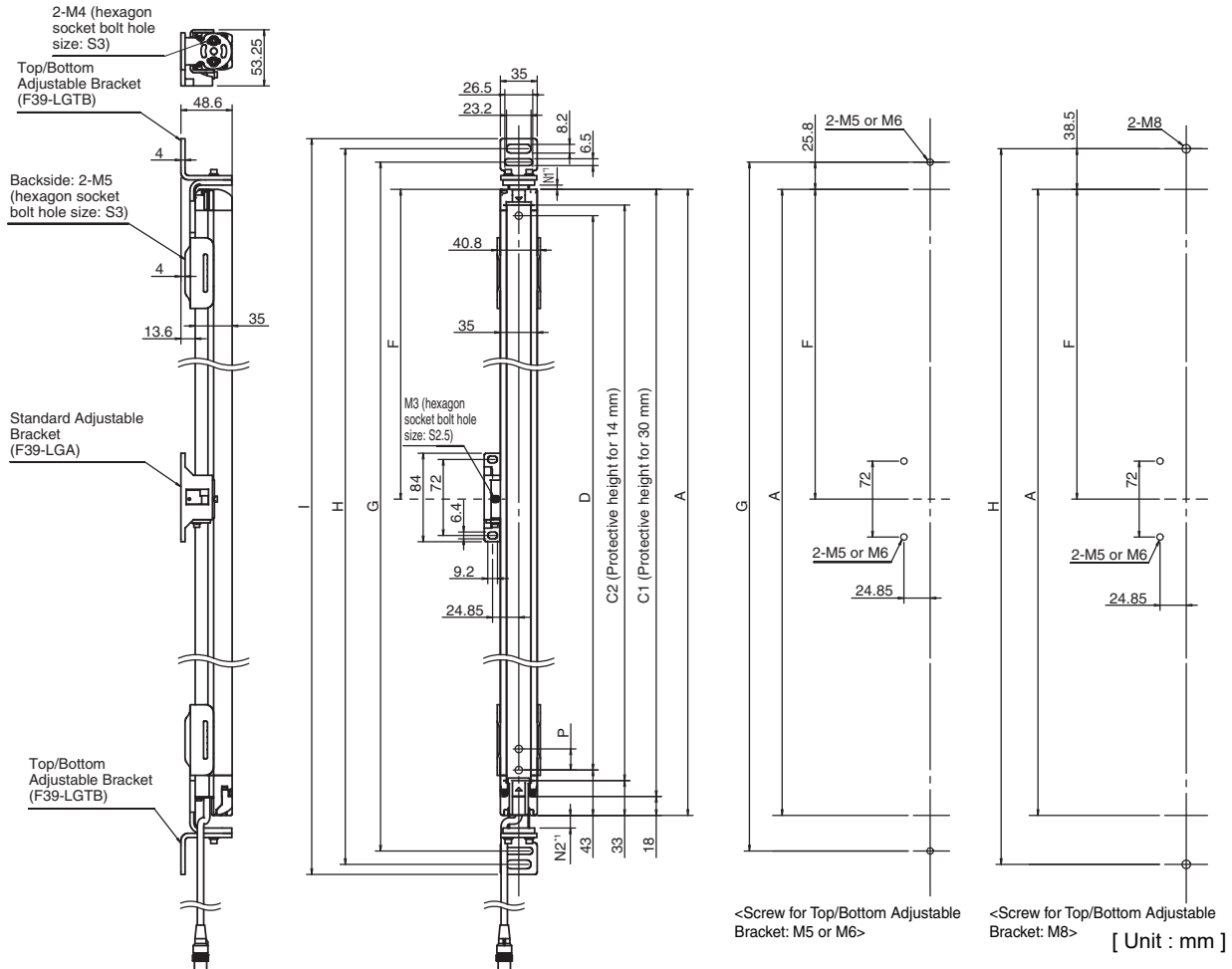

#### F3SG-□RA□□□□-30 Series

	Optional accessory not connected	Optional accessory connected		
		F39-JGR2W	F39-BT	F39-LP F39-BTLP
Dimension A	C1+18	Same as on the left		
Dimension C1	4-digit number of the type name (Protective height)	Same as on the left		
Dimension D	C1-50	Same as on the left		
Dimension G	C1+N1+N2+61.5	C1+N2+68.5	C1+N2+79	C1+N2+90.5
Dimension H	C1+N1+N2+87	C1+N2+94	C1+N2+104.5	C1+N2+116
Dimension I	C1+N1+N2+106	C1+N2+113	C1+N2+123.5	C1+N2+135
Dimension P	20	Same as on the left		

\*1.N1 can be adjusted from 0 mm to 30 mm and N2 from 0 mm to 12 mm.

Protective height (C1)	Number of Top/Bottom Adjustable Brackets *1	Number of Standard Adjustable Brackets *1 *2	Dimension F
0270 to 1070	2	0	-
1150 to 1950	2	1	1000 mm max.
2030 to 2510	2	2	1000 mm max.

\*1.The number of brackets required to mount either one of emitter and receiver.

\*2.The Top/Bottom Adjustable Bracket is not useable together with the Standard Fixed Bracket. When it is necessary to use it with another bracket, only the combination with the Standard Adjustable Bracket is possible.

#### F3SG-□RA□□□□-14 Series

	Optional accessory not connected	Optional accessory connected		
		F39-JGR2W	F39-BT	F39-LP F39-BTLP
Dimension A	C2+48	Same as on the left		
Dimension C2	4-digit number of the type name (Protective height)	Same as on the left		
Dimension D	C2-20	Same as on the left		
Dimension G	C2+N1+N2+91.5	C2+N2+98.5	C2+N2+109	C2+N2+120.5
Dimension H	C2+N1+N2+117	C2+N2+124	C2+N2+135	C2+N2+146
Dimension I	C2+N1+N2+136	C2+N2+143	C2+N2+154	C2+N2+165
Dimension P	10	Same as on the left		

Protective height (C2)	Number of Top/Bottom Adjustable Brackets *1	Number of Standard Adjustable Brackets *1 *2	Dimension F
0240 to 1040	2	0	-
1120 to 1920	2	1	1000 mm max.
2000 to 2080	2	2	1000 mm max.



## Accessories

### Sensor Mounting Brackets

#### Standard Fixed Bracket (F39-LGF)

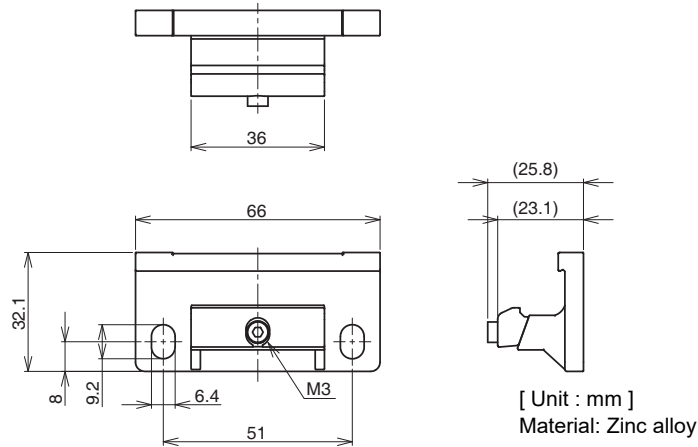

#### Standard Adjustable Bracket (F39-LGA, sold separately)

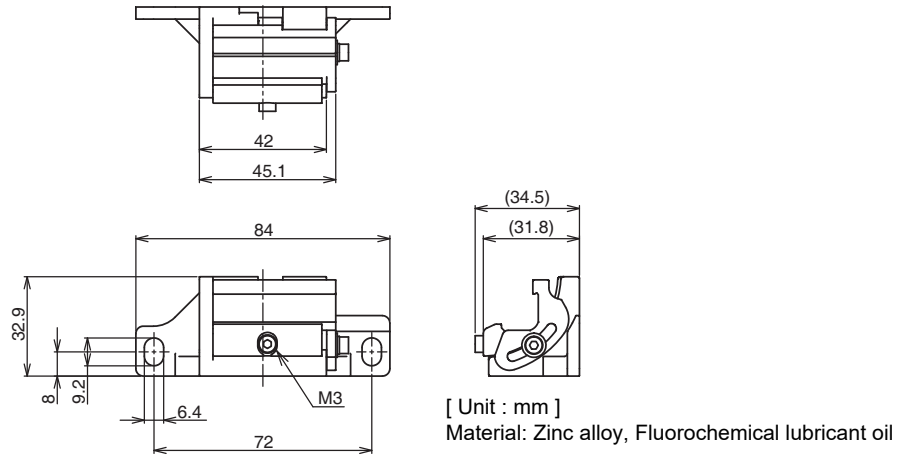

#### Top/Bottom Adjustable Bracket (F39-LGTB, sold separately)

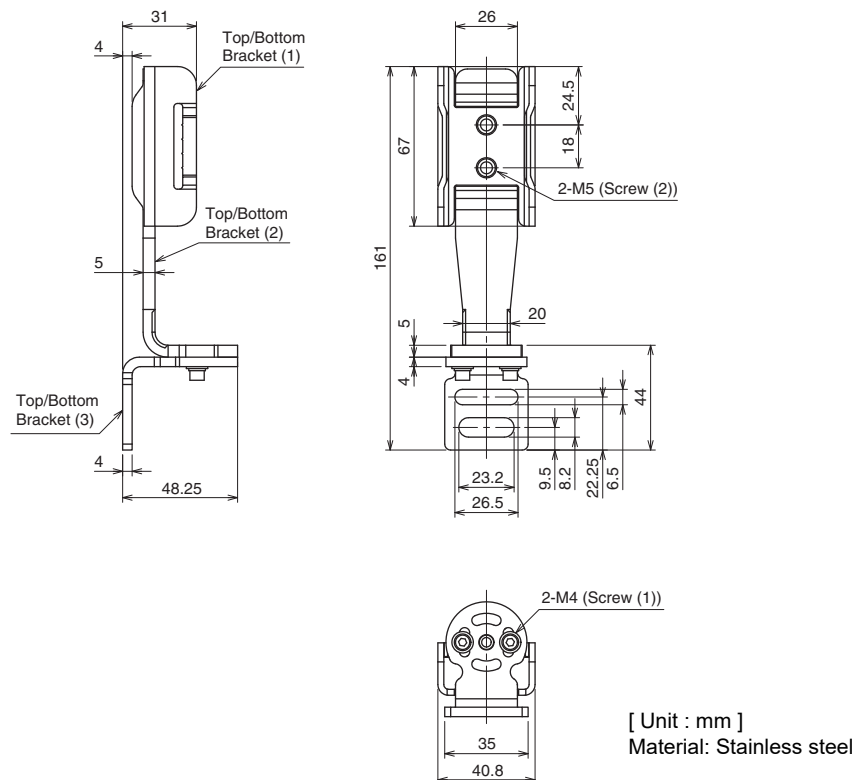

Safety light curtain connecting cable

Single-Ended Cable for Emitter (F39-JG□A-L, sold separately)

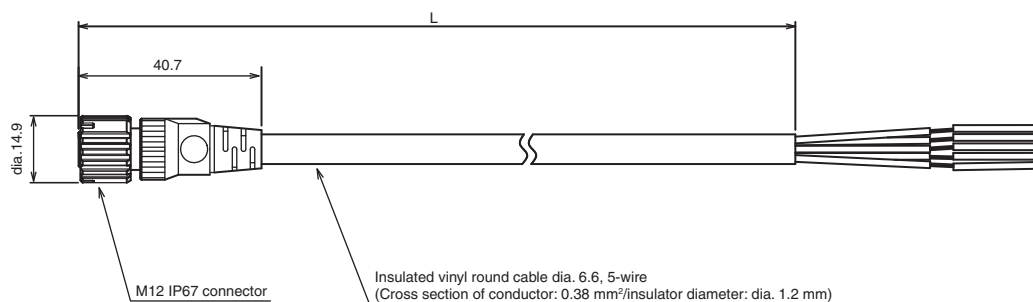

Single-Ended Cable for Receiver (F39-JG□A-D, sold separately)

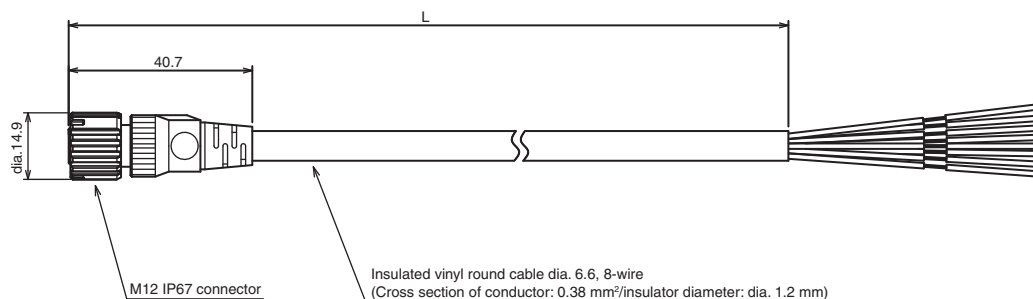

Emitter cable (Gray)	Receiver cable (Black)	L (m)
F39-JG3A-L	F39-JG3A-D	3
F39-JG7A-L	F39-JG7A-D	7
F39-JG10A-L	F39-JG10A-D	10
F39-JG15A-L	F39-JG15A-D	15
F39-JG20A-L	F39-JG20A-D	20

Double-Ended Cable for Emitter: Cable for extension (F39-JG□B-L, sold separately)

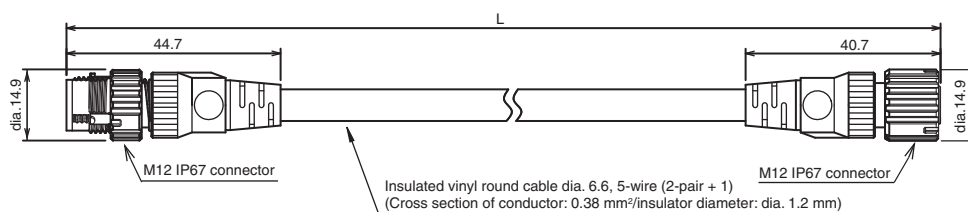

Double-Ended Cable for Receiver: Cable for extension (F39-JG□B-D, sold separately)

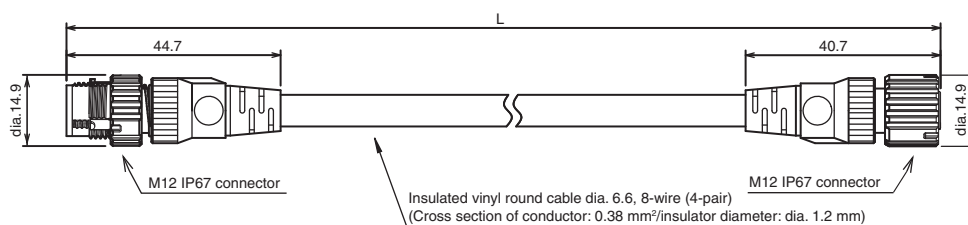

Emitter cable (Gray)	Receiver cable (Black)	L (m)
F39-JGR5B-L	F39-JGR15B-D	0.5
F39-JG1B-L	F39-JG1B-D	1
F39-JG3B-L	F39-JG3B-D	3
F39-JG5B-L	F39-JG5B-D	5
F39-JG7B-L	F39-JG7B-D	7
F39-JG10B-L	F39-JG10B-D	10
F39-JG15B-L	F39-JG15B-D	15
F39-JG20B-L	F39-JG20B-D	20

## Cascading Cable for Emitter (F39-JGR2W-L, sold separately)

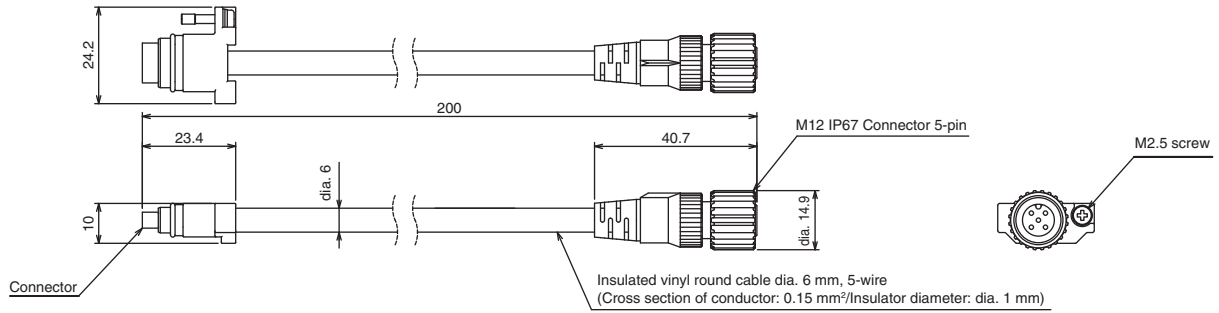

## Cascading Cable for Receiver (F39-JGR2W-D, sold separately)

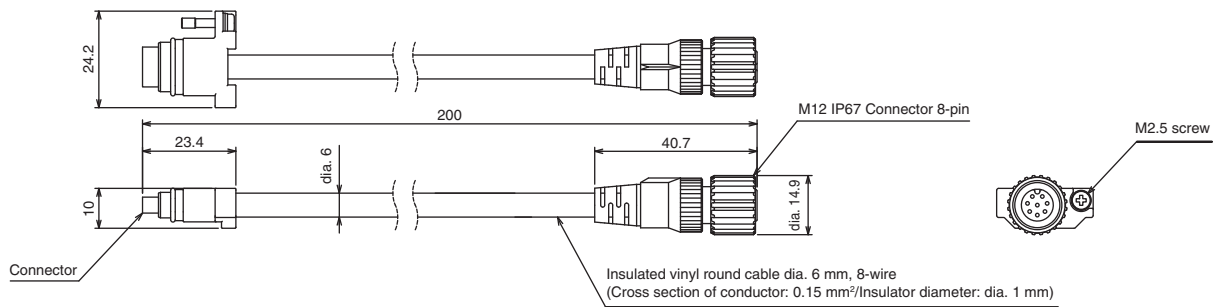

## Y-Joint Plug/Socket Connector (F39-GCNY2, sold separately)

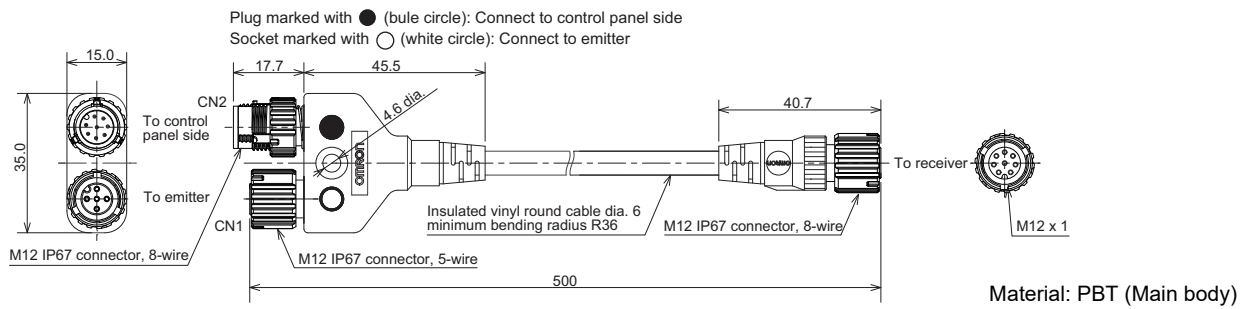

## Interface Unit (F39-GIF, sold separately)

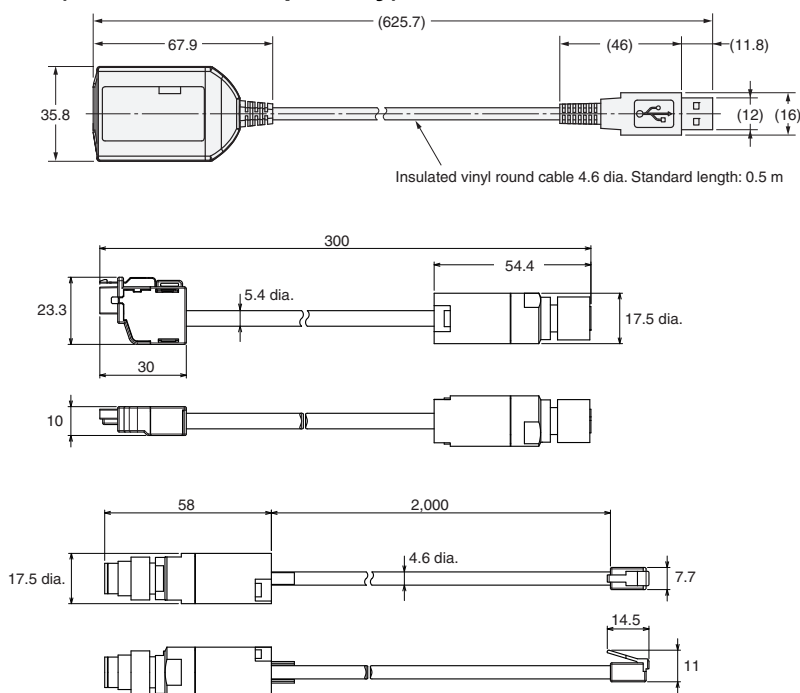

**Spatter Protection Cover (F39-HGA, sold separately)**

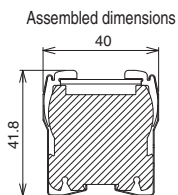

Model	Total length
F39-HGA□□□□	□□□□+4
F39-HGA0550	558

Material: PC (Transparent cover)  
 ABS (Side wall)  
 Stainless steel (Bracket)  
 Aluminum adhesive tape  
 (Fixing sticker)

**Bluetooth Communication Unit (F39-BT, sold separately)**

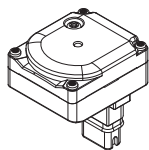

Material: PBT

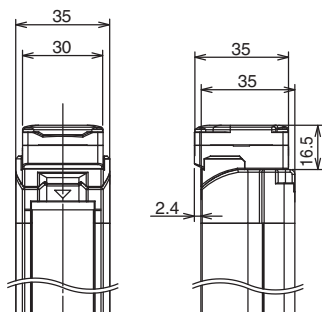

**Lamp and Bluetooth Communication Unit (F39-BTLP, sold separately)  
 Lamp (F39-LP, sold separately)**

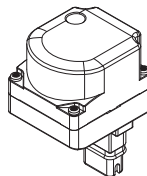

Material:  
 PC (Lighting element)  
 PBT (Other body parts)

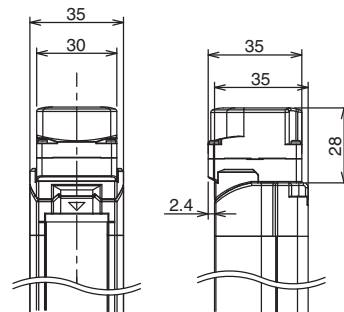

**Related Manuals**

ManNo.	Model	Manual name
Z352	F3SG-R□□□□□□□□	Safety Light Curtain F3SG-□R Series User's Manual

# Safety Light Curtain Robust type

# F3SG-RR

## Enhanced Cutting Oil Resistance

- Mechanical seal structure prevents cutting oil from getting inside
- Special materials and cables significantly enhanced cutting oil resistance
- Rugged and compact housing. Perfect fit installation
- IP67G (JIS C 0920 Annex 1) rated



## System Configuration

### Mounting bracket



### Accessory \*1

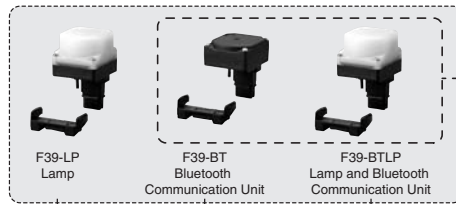

### Accessory

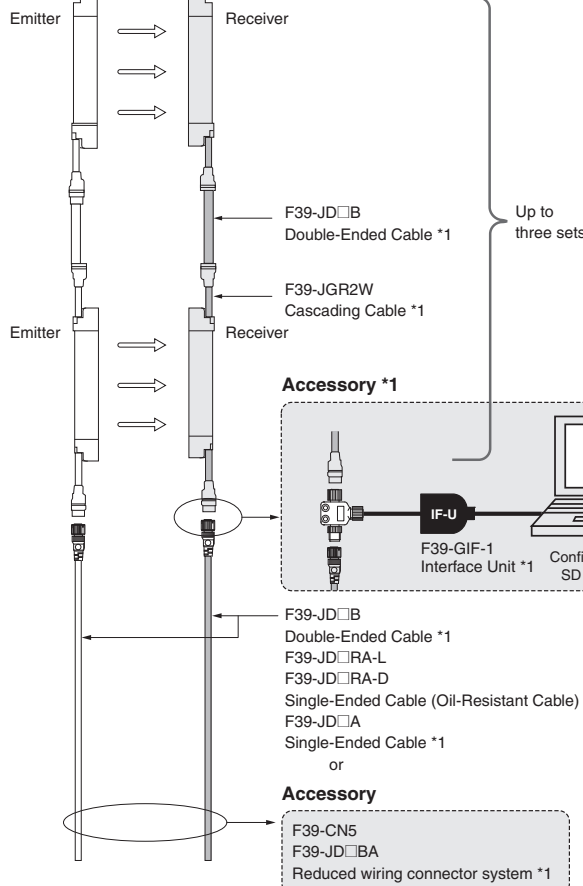

### Recommended safety controller \*2

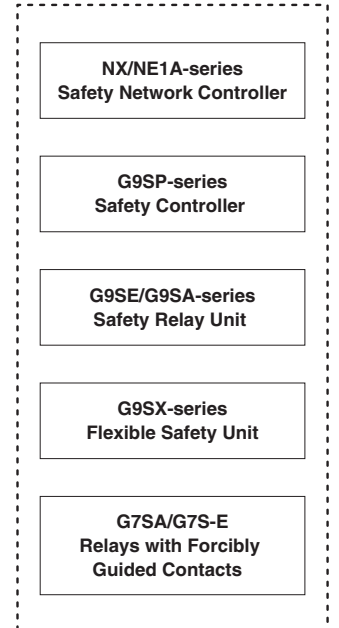

\*1. When the accessory is used, protect it from cutting oil.  
 \*2. The recommended safety controller is required to build a safety circuit using emergency stop switches and door switches.

## Ordering Information

### Main Units

#### Safety Light Curtain

##### Finger protection

Number of beams	Protective height (mm)	Model
23	240	F3SG-4RR0240-14
31	320	F3SG-4RR0320-14
39	400	F3SG-4RR0400-14
47	480	F3SG-4RR0480-14
55	560	F3SG-4RR0560-14
63	640	F3SG-4RR0640-14
71	720	F3SG-4RR0720-14
79	800	F3SG-4RR0800-14
87	880	F3SG-4RR0880-14
95	960	F3SG-4RR0960-14
103	1040	F3SG-4RR1040-14
111	1120	F3SG-4RR1120-14
119	1200	F3SG-4RR1200-14
127	1280	F3SG-4RR1280-14
135	1360	F3SG-4RR1360-14
143	1440	F3SG-4RR1440-14
151	1520	F3SG-4RR1520-14
159	1600	F3SG-4RR1600-14
167	1680	F3SG-4RR1680-14
175	1760	F3SG-4RR1760-14
183	1840	F3SG-4RR1840-14
191	1920	F3SG-4RR1920-14

##### Hand and arm protection

Number of beams	Protective height (mm)	Model
12	240	F3SG-4RR0240-25
16	320	F3SG-4RR0320-25
20	400	F3SG-4RR0400-25
24	480	F3SG-4RR0480-25
28	560	F3SG-4RR0560-25
32	640	F3SG-4RR0640-25
36	720	F3SG-4RR0720-25
40	800	F3SG-4RR0800-25
44	880	F3SG-4RR0880-25
48	960	F3SG-4RR0960-25
52	1040	F3SG-4RR1040-25
56	1120	F3SG-4RR1120-25
60	1200	F3SG-4RR1200-25
64	1280	F3SG-4RR1280-25
68	1360	F3SG-4RR1360-25
72	1440	F3SG-4RR1440-25
76	1520	F3SG-4RR1520-25
80	1600	F3SG-4RR1600-25
84	1680	F3SG-4RR1680-25
88	1760	F3SG-4RR1760-25
92	1840	F3SG-4RR1840-25
96	1920	F3SG-4RR1920-25



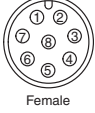
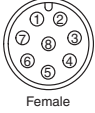
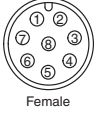

## Accessories (Sold separately)

### Safety light curtain connecting cable Single-Ended Cable (Oil-Resistant Cable)

Appearance	Type	Cable length	Specifications	Model																								
	For emitter M12 connector (8-pin), 5 wires Color: Gray	3 m	For emitter, M12 connector (8-pin), Color: Gray Connected to Power Cable or Double-Ended Cable  Female <table border="1"> <tr><td>1</td><td>-</td><td>Not used</td></tr> <tr><td>2</td><td>Brown</td><td>+24 VDC</td></tr> <tr><td>3</td><td>Black</td><td>TEST</td></tr> <tr><td>4</td><td>-</td><td>Not used</td></tr> <tr><td>5</td><td>Gray</td><td>Not used</td></tr> <tr><td>6</td><td>Pink</td><td>Not used</td></tr> <tr><td>7</td><td>Blue</td><td>0 VDC</td></tr> <tr><td>8</td><td>-</td><td>Not used</td></tr> </table>	1	-	Not used	2	Brown	+24 VDC	3	Black	TEST	4	-	Not used	5	Gray	Not used	6	Pink	Not used	7	Blue	0 VDC	8	-	Not used	F39-JD3RA-L
		1	-	Not used																								
	2	Brown	+24 VDC																									
	3	Black	TEST																									
4	-	Not used																										
5	Gray	Not used																										
6	Pink	Not used																										
7	Blue	0 VDC																										
8	-	Not used																										
7 m	For receiver, M12 connector (8-pin), Color: Black Connected to Power Cable or Double-Ended Cable  Female <table border="1"> <tr><td>1</td><td>White</td><td>OSSD 2</td></tr> <tr><td>2</td><td>Brown</td><td>+24 VDC</td></tr> <tr><td>3</td><td>Black</td><td>OSSD 1</td></tr> <tr><td>4</td><td>Yellow</td><td>AUX</td></tr> <tr><td>5</td><td>Gray</td><td>MUTE A /PC COM (+)</td></tr> <tr><td>6</td><td>Pink</td><td>MUTE B /PC COM (-)</td></tr> <tr><td>7</td><td>Blue</td><td>0 VDC</td></tr> <tr><td>8</td><td>Red</td><td>RESET/EDM</td></tr> </table>	1	White	OSSD 2	2	Brown	+24 VDC	3	Black	OSSD 1	4	Yellow	AUX	5	Gray	MUTE A /PC COM (+)	6	Pink	MUTE B /PC COM (-)	7	Blue	0 VDC	8	Red	RESET/EDM	F39-JD7RA-L		
1	White	OSSD 2																										
2	Brown	+24 VDC																										
3	Black	OSSD 1																										
4	Yellow	AUX																										
5	Gray	MUTE A /PC COM (+)																										
6	Pink	MUTE B /PC COM (-)																										
7	Blue	0 VDC																										
8	Red	RESET/EDM																										
For receiver M12 connector (8-pin), 8 wires Color: Black	3 m	For emitter, M12 connector (8-pin), Color: Gray Connected to Power Cable or Double-Ended Cable  Female <table border="1"> <tr><td>1</td><td>White</td><td>OSSD 2</td></tr> <tr><td>2</td><td>Brown</td><td>+24 VDC</td></tr> <tr><td>3</td><td>Black</td><td>OSSD 1</td></tr> <tr><td>4</td><td>Yellow</td><td>AUX</td></tr> <tr><td>5</td><td>Gray</td><td>MUTE A /PC COM (+)</td></tr> <tr><td>6</td><td>Pink</td><td>MUTE B /PC COM (-)</td></tr> <tr><td>7</td><td>Blue</td><td>0 VDC</td></tr> <tr><td>8</td><td>Red</td><td>RESET/EDM</td></tr> </table>	1	White	OSSD 2	2	Brown	+24 VDC	3	Black	OSSD 1	4	Yellow	AUX	5	Gray	MUTE A /PC COM (+)	6	Pink	MUTE B /PC COM (-)	7	Blue	0 VDC	8	Red	RESET/EDM	F39-JD3RA-D	
	1	White	OSSD 2																									
2	Brown	+24 VDC																										
3	Black	OSSD 1																										
4	Yellow	AUX																										
5	Gray	MUTE A /PC COM (+)																										
6	Pink	MUTE B /PC COM (-)																										
7	Blue	0 VDC																										
8	Red	RESET/EDM																										
7 m	IP67 and IP67G (JIS C 0920 Annex 1)* rated when mated. * F3SG-RR meets the degree of protection when this cable is correctly connected with the power cable of the F3SG-RR. The degree of protection is not satisfied with the part where cable wires are uncovered.	F39-JD7RA-D																										

**Note:** To extend the cable length to more than 7 m, add the F39-JD□B Double-Ended Cable. When the Double-Ended Cable is used, protect it from cutting oil.

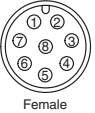
### Single-Ended Cable (2 cables per set, one for emitter and one for receiver) \*

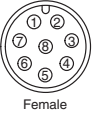
Appearance	Cable length	Specifications	Model																											
	3 m	For emitter M12 connector (8-pin), Color: Gray Connected to Power Cable or Double-Ended Cable  Female <table border="1"> <tr><td>1</td><td>White</td><td>Not used</td></tr> <tr><td>2</td><td>Brown</td><td>+24 VDC</td></tr> <tr><td>3</td><td>Black</td><td>TEST</td></tr> <tr><td>4</td><td>Yellow</td><td>Not used</td></tr> <tr><td>5</td><td>Gray</td><td>Not used</td></tr> <tr><td>6</td><td>Pink</td><td>Not used</td></tr> <tr><td>7</td><td>Blue</td><td>0 VDC</td></tr> <tr><td>8</td><td>Red</td><td>Not used</td></tr> <tr><td colspan="2"></td><td>Shield</td></tr> </table>	1	White	Not used	2	Brown	+24 VDC	3	Black	TEST	4	Yellow	Not used	5	Gray	Not used	6	Pink	Not used	7	Blue	0 VDC	8	Red	Not used			Shield	F39-JD3A
	1	White	Not used																											
	2	Brown	+24 VDC																											
	3	Black	TEST																											
	4	Yellow	Not used																											
5	Gray	Not used																												
6	Pink	Not used																												
7	Blue	0 VDC																												
8	Red	Not used																												
		Shield																												
7 m	For receiver M12 connector (8-pin), Color: Black Connected to Power Cable or Double-Ended Cable  Female <table border="1"> <tr><td>1</td><td>White</td><td>OSSD 2</td></tr> <tr><td>2</td><td>Brown</td><td>+24 VDC</td></tr> <tr><td>3</td><td>Black</td><td>OSSD 1</td></tr> <tr><td>4</td><td>Yellow</td><td>AUX</td></tr> <tr><td>5</td><td>Gray</td><td>MUTE A /PC COM (+)</td></tr> <tr><td>6</td><td>Pink</td><td>MUTE B /PC COM (-)</td></tr> <tr><td>7</td><td>Blue</td><td>0 VDC</td></tr> <tr><td>8</td><td>Red</td><td>RESET/EDM</td></tr> <tr><td colspan="2"></td><td>Shield</td></tr> </table>	1	White	OSSD 2	2	Brown	+24 VDC	3	Black	OSSD 1	4	Yellow	AUX	5	Gray	MUTE A /PC COM (+)	6	Pink	MUTE B /PC COM (-)	7	Blue	0 VDC	8	Red	RESET/EDM			Shield	F39-JD7A	
1	White	OSSD 2																												
2	Brown	+24 VDC																												
3	Black	OSSD 1																												
4	Yellow	AUX																												
5	Gray	MUTE A /PC COM (+)																												
6	Pink	MUTE B /PC COM (-)																												
7	Blue	0 VDC																												
8	Red	RESET/EDM																												
		Shield																												
10 m	For emitter M12 connector (8-pin), Color: Gray Connected to Power Cable or Double-Ended Cable  Female <table border="1"> <tr><td>1</td><td>White</td><td>Not used</td></tr> <tr><td>2</td><td>Brown</td><td>+24 VDC</td></tr> <tr><td>3</td><td>Black</td><td>TEST</td></tr> <tr><td>4</td><td>Yellow</td><td>Not used</td></tr> <tr><td>5</td><td>Gray</td><td>Not used</td></tr> <tr><td>6</td><td>Pink</td><td>Not used</td></tr> <tr><td>7</td><td>Blue</td><td>0 VDC</td></tr> <tr><td>8</td><td>Red</td><td>Not used</td></tr> <tr><td colspan="2"></td><td>Shield</td></tr> </table>	1	White	Not used	2	Brown	+24 VDC	3	Black	TEST	4	Yellow	Not used	5	Gray	Not used	6	Pink	Not used	7	Blue	0 VDC	8	Red	Not used			Shield	F39-JD10A	
1	White	Not used																												
2	Brown	+24 VDC																												
3	Black	TEST																												
4	Yellow	Not used																												
5	Gray	Not used																												
6	Pink	Not used																												
7	Blue	0 VDC																												
8	Red	Not used																												
		Shield																												
15 m	For receiver M12 connector (8-pin), Color: Black Connected to Power Cable or Double-Ended Cable  Female <table border="1"> <tr><td>1</td><td>White</td><td>OSSD 2</td></tr> <tr><td>2</td><td>Brown</td><td>+24 VDC</td></tr> <tr><td>3</td><td>Black</td><td>OSSD 1</td></tr> <tr><td>4</td><td>Yellow</td><td>AUX</td></tr> <tr><td>5</td><td>Gray</td><td>MUTE A /PC COM (+)</td></tr> <tr><td>6</td><td>Pink</td><td>MUTE B /PC COM (-)</td></tr> <tr><td>7</td><td>Blue</td><td>0 VDC</td></tr> <tr><td>8</td><td>Red</td><td>RESET/EDM</td></tr> <tr><td colspan="2"></td><td>Shield</td></tr> </table>	1	White	OSSD 2	2	Brown	+24 VDC	3	Black	OSSD 1	4	Yellow	AUX	5	Gray	MUTE A /PC COM (+)	6	Pink	MUTE B /PC COM (-)	7	Blue	0 VDC	8	Red	RESET/EDM			Shield	F39-JD15A	
1	White	OSSD 2																												
2	Brown	+24 VDC																												
3	Black	OSSD 1																												
4	Yellow	AUX																												
5	Gray	MUTE A /PC COM (+)																												
6	Pink	MUTE B /PC COM (-)																												
7	Blue	0 VDC																												
8	Red	RESET/EDM																												
		Shield																												
20 m	IP67* rated when mated. * When the accessory is used, protect it from cutting oil.	F39-JD20A																												

\* The cable for emitter and the cable for receiver are available separately. Add '-L' for emitter or '-D' for receiver to the end of the model number when you order.

Single-Ended Cable for Emitter: F39-JD□A-L, Single-Ended Cable for Receiver: F39-JD□A-D

**Note:** 1. Use the F39-JD□RA-L/-D for applications where cutting oil resistance is required.  
2. To extend the cable length to more than 20 m, add the F39-JD□B Double-Ended Cable.

**Double-Ended Cable (2 cables per set, one for emitter and one for receiver) \***

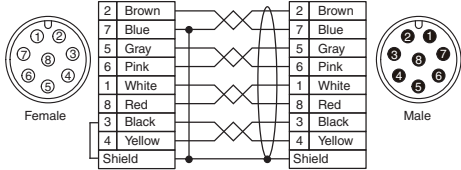
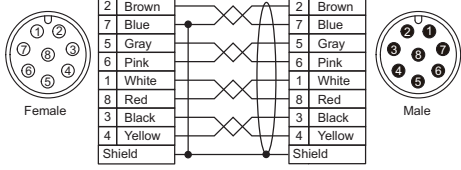
Appearance	Cable length	Specifications	Model
	0.5 m	For emitter M12 connector (8-pin), Color: Gray Connected to Power Cable or Double-Ended Cable Connected to Single-Ended Cable, or Double-Ended Cable	F39-JDR5B
	1 m		F39-JD1B
	3 m		F39-JD3B
	5 m		F39-JD5B
	7 m	For receiver, M12 connector(8-pin) Color: Black Connected to Power Cable or Double-Ended Cable Connected to Single-Ended Cable, or Double-Ended Cable	F39-JD7B
	10 m		F39-JD10B
	15 m		F39-JD15B
	20 m	IP67* rated when mated. * When the accessory is used, protect it from cutting oil.	F39-JD20B

\* The cable for emitter and the cable for receiver are available separately. Add '-L' for emitter or '-D' for receiver to the end of the model number when you order.

Double-Ended Cable for Emitter: F39-JD□B-L, Double-Ended Cable for Receiver: F39-JD□B-D

**Note:** To extend the cable length to more than 20 m, add the F39-JD□B Double-Ended Cable to the F39-JD□A Single-Ended Cable.

To extend the cable length to more than 40 m, add several Double-Ended Cables to the Single-Ended Cable.

Example: To extend the cable length to 50 m, connect two F39-JD20B (20 m) cables and one F39-JD10A (10 m) cable.

**<Connection example>**

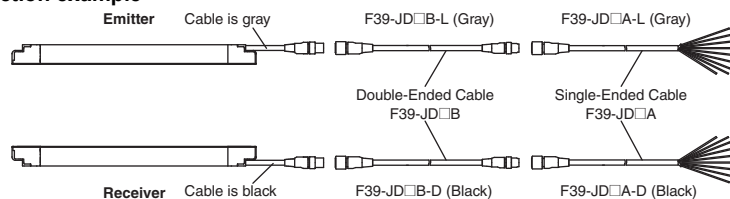

**Reduced Wiring Connector System (Order the F39-CN5 and Cables for Reduce Wiring.)**  
**Reduced Wiring Connector**

Appearance	Specifications	Model
	IP67* rated when mated. * When the accessory is used, protect it from cutting oil.	F39-CN5

**Note:** When using the Reduced Wiring Connector (F39-CN5), the following functions are not available.

- Manual Reset
- External Device Monitoring
- Auxiliary Output

Make sure to keep the settings in the factory default.

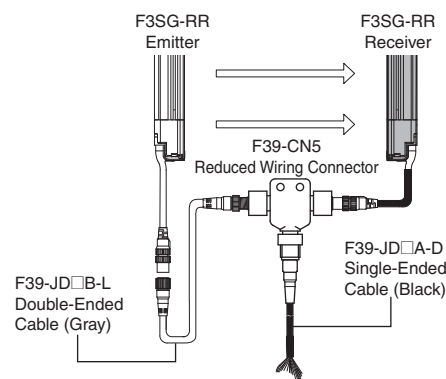

**Cable for Reduce Wiring\* (2 cables per set, one for emitter and one for receiver)**

Appearance	Cable length	Specifications	Remarks	Model
	Emitter: 3 m Receiver: 3 m	IP67* rated when mated. * When the accessory is used, protect it from cutting oil.	Double-Ended Cable: F39-JD3B-L Single-Ended Cable: F39-JD3A-D	F39-JD0303BA
	Emitter: 3 m Receiver: 7 m		Double-Ended Cable: F39-JD3B-L Single-Ended Cable: F39-JD7A-D	F39-JD0307BA
	Emitter: 3 m Receiver: 10 m		Double-Ended Cable: F39-JD3B-L Single-Ended Cable: F39-JD10A-D	F39-JD0310BA
	Emitter: 5 m Receiver: 3 m		Double-Ended Cable: F39-JD5B-L Single-Ended Cable: F39-JD3A-D	F39-JD0503BA
	Emitter: 5 m Receiver: 7 m		Double-Ended Cable: F39-JD5B-L Single-Ended Cable: F39-JD7A-D	F39-JD0507BA
	Emitter: 5 m Receiver: 10 m		Double-Ended Cable: F39-JD5B-L Single-Ended Cable: F39-JD10A-D	F39-JD0510BA
	Emitter: 10 m Receiver: 3 m		Double-Ended Cable: F39-JD10B-L Single-Ended Cable: F39-JD3A-D	F39-JD1003BA
	Emitter: 10 m Receiver: 7 m		Double-Ended Cable: F39-JD10B-L Single-Ended Cable: F39-JD7A-D	F39-JD1007BA
	Emitter: 10 m Receiver: 10 m		Double-Ended Cable: F39-JD10B-L Single-Ended Cable: F39-JD10A-D	F39-JD1010BA

**Note:** A combination of emitter and receiver cables of other lengths than the above is also available. For details, contact your Omron representative.

\* Double-Ended Cable for emitter and Single-Ended Cable for receiver.

F3SG-RR

# F3SG-RR



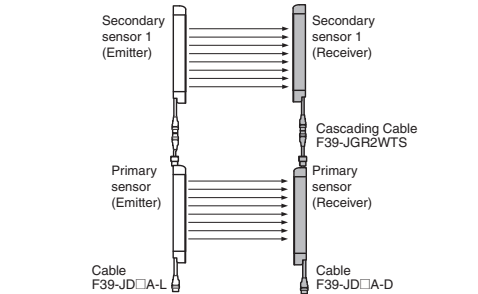

## Cascading Cable (2 cables per set, one for emitter and one for receiver)

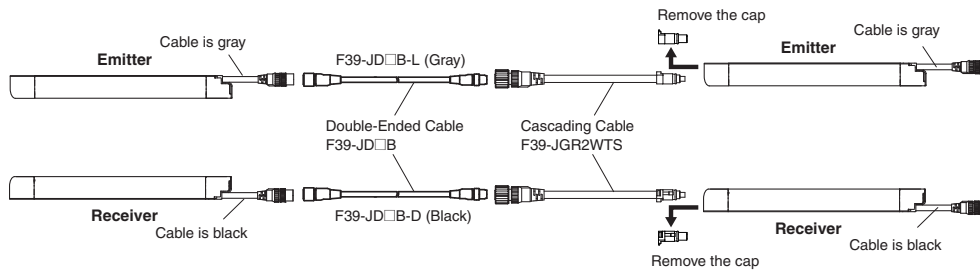
Appearance	Type	Cable length	Specifications	Model
	Cap (8-pin), M12 connector (8-pin)	0.2 m	 <p>IP67* rated when mated. * When the accessory is used, protect it from cutting oil.</p>	<b>F39-JGR2WTS</b>

**Note:** The Double-Ended Cable (up to 10 m: F39-JD10B) can be added to extend the cable length between the series-connected sensors. Cable length between sensors: 10 m max. (not including cascading cable (F39-JGR2WTS) and power cable)



## Sensor Mounting Brackets



Appearance	Specifications	Application	Model
	Free-Location Bracket (Intermediate Bracket)	Beam alignment after mounting possible. The angle adjustment range is $\pm 15^\circ$ . Side mounting and backside mounting possible. (Sold separately as a set of 2 brackets. Refer to note *1 for the number of sets required for each model.)	<b>F39-LGRA</b>
	Top/Bottom Bracket *2	Use this bracket at the top and bottom positions of the F3SG-RR. Beam alignment after mounting possible. The angle adjustment range is $\pm 22.5^\circ$ . Side mounting and backside mounting possible. (Sold separately as a set of 4 brackets.)	<b>F39-LGRTB</b>
	Top/Bottom Bracket *2	The part of this bracket to contact with a wall surface has a different shape from the F39-LGRTB Top/Bottom Bracket. Use this bracket when replacing an existing safety light curtain with the F3SG-RR. (Sold separately as a set of 4 brackets.)	<b>F39-LGRTB-2</b>
	Top/Bottom Bracket *2	Select a bracket that fit into the existing mounting hole.	<b>F39-LGRTB-3</b>

\*1. Protective height of 0240 to 1200 mm: 2 sets, Protective height of 1280 to 1920 mm: 3 sets

\*2. Use the Top/Bottom Bracket in combination with the Intermediate Bracket.

Protective height of 1040 or less: The Intermediate Bracket is not required. Please purchase 1 set of Top/Bottom Brackets (F39-LGRTB(-2/-3)). Protective height of 1120 to 1920: Please purchase 1 set of Top/Bottom Brackets (F39-LGRTB(-2/-3)) and 1 set of Intermediate Brackets (F39-LGRA).

**Interface units and configuration tool SD Manager 2 \***

Appearance	Type	Specifications	Model
	SD Manager 2	The Configuration Tool SD Manager 2 is available to download from our website at <a href="http://www.ia.omron.com/f3sg-r_tool">http://www.ia.omron.com/f3sg-r_tool</a>	—
	Interface Unit	F39-GIF-1 interface unit to connect the F3SG-RR receiver to a USB port of the PC  Accessories: F39-CN1 Branch Connector (1), Connector Cap (1), 2-m Dedicated Cable (1), Instruction Manual	<b>F39-GIF-1</b>
	Bluetooth Communication Unit	F39-BT bluetooth unit to enable bluetooth on the F3SG-RR  IP67 rated when mated.	<b>F39-BT</b>

\* When the accessory is used, protect it from cutting oil.

**Lamp \***

Appearance	Type	Specifications	Model
	Lamp	The lamp unit can be connected to a receiver and turned ON based on the operation of F3SG-RA/RR. The lamp can indicate red, orange, and green colors, to which three different states can be assigned.	<b>F39-LP</b>
	Lamp and Bluetooth Communication Unit	IP67 rated when mated.	<b>F39-BTLP</b>

\* When the accessory is used, protect it from cutting oil.

**End Cap \*1 \*2**

Appearance	Specifications	Model
	Housing color: Black For both emitter and receiver (Attached to the F3SG-RR. The End Cap can be purchased if lost.) IP67 rated when mated.	<b>F39-CNM</b>

\*1. This accessory can also be used with the F3SG-RA.

\*2. When the accessory is used, protect it from cutting oil.

**Laser Pointer for F3SG-R \***

Appearance	Specifications	Model
	The laser pointer is attached on the optical surface of the F3SG-R to help coarse adjustment of beams.	<b>F39-PTG</b>

\* When the accessory is used, protect it from cutting oil.

**Test Rod**

Diameter	Model
14 mm dia.	<b>F39-TRD14</b>
25 mm dia.	<b>F39-TRD25</b>

# Ratings and Specifications

## Main unit

The □□□□ in the model names indicate the protective heights in millimeters.

		F3SG-4RR□□□□-14	F3SG-4RR□□□□-25	
Performance	Object Resolution (Detection Capability)	Opaque objects 14-mm dia.	25-mm dia.	
	Beam Gap	10 mm	20 mm	
	Number of Beams	23 to 191	12 to 96	
	Lens Size	5.2 × 3.4 (W × H) mm	6.0 × 5.0 (W × H) mm	
	Protective Height	240 to 1920 mm		
	Operating Range	0.3 to 10.0 m	0.3 to 17.0 m	
	Response Time	ON to OFF	Normal mode: 8 to 18 ms *1 Slow mode: 16 to 36 ms *1 *2	
		OFF to ON	Normal mode: 40 to 90ms (synchronized), 140 to 190ms (not synchronized) *1	
		*1. Response time when used in one segment system or in cascaded connection. Refer to page 52. *2. Selectable by Configuration Tool.		
	Effective Aperture Angle (EAA) (IEC 61496-2)	±2.5° max., emitter and receiver at operating range of 3 m or greater		
	Light Source	Infrared LEDs, Wavelength: 870 nm		
Startup Waiting Time	2 s max.			
Electrical	Power Supply Voltage (Vs)	SELV/PELV 24 VDC±20% (ripple p-p 10% max.)		
	Current Consumption	Refer to page 52 .		
	Safety Outputs (OSSD)	Two PNP or NPN transistor outputs (PNP or NPN is selectable by Configuration Tool.)		
		Load current of 300 mA max., Residual voltage of 2 V max. (except for voltage drop due to cable extension), Capacitive load of 1 μF max., Inductive load of 2.2 H max. *1 Leakage current of 1 mA max. (PNP), 2 mA max. (NPN) *2		
		*1. The load inductance is the maximum value when the safety output frequently repeats ON and OFF. When you use the safety output at 4 Hz or less, the usable load inductance becomes larger. *2. These values must be taken into consideration when connecting elements including a capacitive load such as a capacitor.		
	Auxiliary Output	One PNP or NPN transistor output (PNP or NPN is selectable by Configuration Tool.) Load current of 100 mA max., Residual voltage of 2 V max .		
	Output Operation Mode	Safety Output	Light-ON (Safety output is enabled when the receiver receives an emitting signal.)	
		Auxiliary Output	Safety output (Inverted signal output:Enable) (default) (Cofigurable by Configuration Tool)	
	Input Voltage	External device monitoring input (Lockout reset input)	PNP ON voltage: Vs-3 V to Vs (short circuit current: approx. 6.5 mA) * OFF voltage: 0 V to 1/2 Vs, or open (short circuit current: approx. 8.0 mA) * NPN ON voltage: 0 V to 3 V (short circuit current: approx. 8.0 mA) OFF voltage: 1/2 Vs to Vs, or open (short circuit current: approx. 6.5 mA) *	
			Muting input A/B	PNP ON voltage: Vs-3 V to Vs (short circuit current: approx. 3.0 mA) * OFF voltage: 0 V to 1/2 Vs, or open (short circuit current: approx. 5.0 mA) * NPN ON voltage: 0 V to 3 V (short circuit current: approx. 5.0 mA) OFF voltage: 1/2 Vs to Vs, or open (short circuit current: approx. 3.0 mA) *
		Test input	24 V Active setting: ON voltage: 9 V to Vs (short circuit current: approx. 2.5 mA) * OFF voltage: 0 V to 3 V or open (short circuit current: approx. 2.0 mA) 0 V Active setting: ON voltage: 0 V to 3 V (short circuit current: approx. 2.0 mA) OFF voltage: 9 V to Vs or open (short circuit current: approx. 2.5 mA) *	
* The Vs indicates a supply voltage value in your environment.				
Overvoltage Category (IEC 60664-1)	II			
Indicators	Refer to page 54.			
Protective Circuit	Output short protection, Power supply reverse polarity protection			
Insulation Resistance	20 MΩ or higher (500 VDC megger)			
Dielectric Strength	1,000 VAC, 50/60 Hz (1 min)			
Functional	Mutual Interference Prevention (Scan Code)	This function prevents mutual interference in up to two F3SG-RR systems.		
	Cascade Connection	Number of cascaded segments: 3 max. Total number of beams: 255 max. Cable length between sensors: 10 m max. (not including cascading cable (F39-JGR2WTS) and power cable)		
		Test Function		
	Safety-Related Functions	Interlock External device monitoring (EDM) Pre-reset Fixed blanking/Floating blanking Reduced resolution Muting/Override Scan code selection PNP/NPN selection Response time adjustment		

		F3SG-4RR□□□□-14	F3SG-4RR□□□□-25	
Environmental	Ambient Temperature	Operating	-10 to 55°C (14 to 131°F) (non-icing)	
		Storage	-25 to 70°C (-13 to 158°F)	
	Ambient Humidity	Operating	35% to 85% (non-condensing)	
		Storage	35% to 95%	
	Ambient Illuminance		Incandescent lamp: 3,000 lx max. on receiver surface Sunlight: 10,000 lx max. on receiver surface	
	Degree of Protection (IEC 60529)		IEC 60529: IP65 and IP67, JIS C 0920 Annex 1: IP67G	
	Vibration Resistance (IEC 61496-1)		Class 3M4 (IEC TR 60721-4-3) Operation limit: 5 to 150 Hz, Multiple amplitude of 7 mm, Acceleration of 1 G, 10 sweeps each in X, Y, and Z directions (no delay at resonant frequencies)	
Shock Resistance (IEC 61496-1)		Class 3M4 (IEC TR 60721-4-3) Operation limit: Acceleration of 15 G, Pulse duration of 6 ms, 100 shocks for each in X, Y, and Z directions (600 shocks in total)		
Pollution Degree (IEC 60664-1)		Pollution Degree 3		
Connections	Power cable	Type of Connection	M12 connectors: 8-pin emitter and receiver. Cables prewired to the sensors. IP67 and IP67G (JIS C 0920 Annex 1) * rated when mated. *F3SG-RR meets the degree of protection when it is correctly connected with an F39-JD□□RA-□ Oil-Resistant cable.	
		Number of Wires	Emitter: 5, Receiver: 8	
		Cable Length	0.3 m	
		Cable Diameter	6 mm	
	Cascading cable	Type of Connection	M12 connectors: 8-pin emitter and receiver. IP67 rated when mated.	
		Number of Wires	Emitter: 5, Receiver: 8	
		Cable Length	0.3 m	
		Cable Diameter	6 mm	
	F39-JD□□RA-□ Oil-Resistant cable - Single-Ended Cable	Type of Connection	M12 connectors: 8-pin emitter and receiver. Cables prewired to the sensors. IP67 and IP67G (JIS C 0920 Annex 1) * rated when mated. * F3SG-RR meets the degree of protection when it is correctly connected with the power cable. The degree of protection is not satisfied with the part where cable wires are uncovered.	
		Number of Wires	Emitter: 5, Receiver: 8	
		Cable Length	Refer to page 46.	
		Cable Diameter	6 mm	
	Extension cable - Single-Ended Cable (F39-JD□A) - Double-Ended Cable (F39-JD□B)	Type of Connection	M12 connectors: 8-pin emitter and receiver. IP67 rated when mated.	
		Number of Wires	Emitter: 8, Receiver: 8	
		Cable Length	Refer to page 46 and 47.	
		Cable Diameter	6.6 mm	
Extension of Power Cable		100 m max. (Emitter/Receiver)		
Material	Material	Housing: Aluminum alloy Cap: PBT resin Front window: Acrylic resin Cable: Fluororesin FE plate: Stainless steel		
	Weight	Refer to page 52 .		
	Included Accessories	Safety Precautions, Quick Installation Manual, Troubleshooting Guide Sticker, Warning Zone Label, End Cap (for switching External Test Input function)		
Conformity	Conforming standards	Refer to page 53.		
	Performance Level (PL)/Safety category	PL e/Category 4 (EN ISO 13849-1:2015)		
	PFFh <sub>d</sub>	1.1 × 10 <sup>-9</sup> (IEC 61508)		
	Proof test interval T <sub>M</sub>	Every 20 years (IEC 61508)		
	SFF	99% (IEC 61508)		
	HFT	1 (IEC 61508)		
Classification		Type B (IEC 61508-2)		

## Bluetooth Communication Unit

Communication System	Bluetooth Version 3.0
Communication Profile	SPP (Serial Port Profile)
Transmission Distance	Approx. 10 m max. (Output power: Class 2) *

\* It depends on use environment conditions.

# F3SG-RR

## List of Models/Response Time/Current Consumption/Weight

### F3SG-4RR□□□□-14

Model	Number of Beams	Protective Height [mm] (Overall length)	Response Time [ms] *1			Current Consumption [mA]		Weight [kg]	
			ON → OFF *2	OFF (Synchronized) → ON	OFF (Not synchronized) → ON	Emitter	Receiver	Net *3	Gross *4
F3SG-4RR0240-14	23	240	8	40	140	45	75	0.7	1.5
F3SG-4RR0320-14	31	320	8	40	140	55	75	0.9	1.7
F3SG-4RR0400-14	39	400	8	40	140	60	80	1.1	2.0
F3SG-4RR0480-14	47	480	13	65	165	50	80	1.3	2.3
F3SG-4RR0560-14	55	560	13	65	165	55	80	1.5	2.5
F3SG-4RR0640-14	63	640	13	65	165	60	85	1.7	2.8
F3SG-4RR0720-14	71	720	13	65	165	65	85	1.9	3.1
F3SG-4RR0800-14	79	800	13	65	165	65	90	2.1	3.4
F3SG-4RR0880-14	87	880	13	65	165	70	90	2.4	3.6
F3SG-4RR0960-14	95	960	13	65	165	75	90	2.6	3.9
F3SG-4RR1040-14	103	1040	13	65	165	80	95	2.8	4.2
F3SG-4RR1120-14	111	1120	13	65	165	85	95	3.0	4.4
F3SG-4RR1200-14	119	1200	13	65	165	90	100	3.2	4.7
F3SG-4RR1280-14	127	1280	13	65	165	95	100	3.4	5.0
F3SG-4RR1360-14	135	1360	13	65	165	95	105	3.6	5.3
F3SG-4RR1440-14	143	1440	18	90	190	85	105	3.8	5.5
F3SG-4RR1520-14	151	1520	18	90	190	90	105	4.0	5.8
F3SG-4RR1600-14	159	1600	18	90	190	90	110	4.2	6.1
F3SG-4RR1680-14	167	1680	18	90	190	95	110	4.4	6.3
F3SG-4RR1760-14	175	1760	18	90	190	100	115	4.6	6.6
F3SG-4RR1840-14	183	1840	18	90	190	100	115	4.8	6.9
F3SG-4RR1920-14	191	1920	18	90	190	105	120	5.0	7.2

\*1. The maximum speed of movement of a test rod up to which the detection capability is maintained is 2.0 m/s.

\*2. The response times are values when Scan Code is set at Code B. The response times for Code A are 1 ms shorter than these values.

\*3. The net weight is the weight of an emitter and a receiver.

\*4. The gross weight is the weight of an emitter, a receiver, included accessories and a package.

### F3SG-4RR□□□□-25

Model	Number of Beams	Protective Height [mm] (Overall length)	Response Time [ms] *1			Current Consumption [mA]		Weight [kg]	
			ON → OFF *2	OFF (Synchronized) → ON	OFF (Not synchronized) → ON	Emitter	Receiver	Net *3	Gross *4
F3SG-4RR0240-25	12	240	8	40	140	35	75	0.7	1.6
F3SG-4RR0320-25	16	320	8	40	140	40	75	0.9	1.9
F3SG-4RR0400-25	20	400	8	40	140	45	75	1.1	2.1
F3SG-4RR0480-25	24	480	8	40	140	50	75	1.3	2.4
F3SG-4RR0560-25	28	560	8	40	140	50	75	1.5	2.7
F3SG-4RR0640-25	32	640	8	40	140	55	75	1.7	3.0
F3SG-4RR0720-25	36	720	8	40	140	60	80	1.9	3.2
F3SG-4RR0800-25	40	800	8	40	140	65	80	2.1	3.5
F3SG-4RR0880-25	44	880	13	65	165	50	80	2.3	3.8
F3SG-4RR0960-25	48	960	13	65	165	50	80	2.5	4.0
F3SG-4RR1040-25	52	1040	13	65	165	55	80	2.7	4.3
F3SG-4RR1120-25	56	1120	13	65	165	55	85	2.9	4.6
F3SG-4RR1200-25	60	1200	13	65	165	55	85	3.1	4.9
F3SG-4RR1280-25	64	1280	13	65	165	60	85	3.3	5.1
F3SG-4RR1360-25	68	1360	13	65	165	60	85	3.5	5.4
F3SG-4RR1440-25	72	1440	13	65	165	65	85	3.7	5.7
F3SG-4RR1520-25	76	1520	13	65	165	65	90	3.9	5.9
F3SG-4RR1600-25	80	1600	13	65	165	70	90	4.1	6.2
F3SG-4RR1680-25	84	1680	13	65	165	70	90	4.3	6.5
F3SG-4RR1760-25	88	1760	13	65	165	70	90	4.5	6.7
F3SG-4RR1840-25	92	1840	13	65	165	75	90	4.7	7.0
F3SG-4RR1920-25	96	1920	13	65	165	75	95	4.9	7.3

\*1. The maximum speed of movement of a test rod up to which the detection capability is maintained is 2.0 m/s.

\*2. The response times are values when Scan Code is set at Code B. The response times for Code A are 1 ms shorter than these values.

\*3. The net weight is the weight of an emitter and a receiver.

\*4. The gross weight is the weight of an emitter, a receiver, included accessories and a package.

## Legislation and Standards

1. The F3SG-RR does not receive type approval provided by Article 44-2 of the Industrial Safety and Health Act of Japan. When using the F3SG-RR in Japan as a "safety system for pressing or shearing machines" prescribed in Article 42 of that law, the machine control system must receive type approval.
2. The F3SG-RR is electro-sensitive protective equipment (ESPE) in accordance with European Union (EU) Machinery Directive Index Annex V, Item 2.
3. EC/EU Declaration of Conformity  
OMRON declares that the F3SG-RR is in conformity with the requirements of the following EC/EU Directives:  
Machinery Directive 2006/42/EC  
EMC Directive 2014/30/EU
4. Conforming Standards
  - (1) European standards  
EN61496-1 (Type 4 ESPE), EN 61496-2 (Type 4 AOPD), EN61508-1 through -4 (SIL 3), EN ISO 13849-1:2015 (PL e, Category 4)
  - (2) International standards  
IEC61496-1 (Type 4 ESPE), IEC61496-2 (Type 4 AOPD), IEC61508-1 through -4 (SIL 3), ISO 13849-1:2015 (PL e, Category 4)
  - (3) JIS standards  
JIS B 9704-1 (Type 4 ESPE), JIS B 9704-2 (Type 4 AOPD)
  - (4) North American standards  
UL61496-1 (Type 4 ESPE), UL61496-2 (Type 4 AOPD), UL508, UL1998, CAN/CSA C22.2 No.14, CAN/CSA C22.2 No.0.8
5. Third-Party Certifications
  - (1) TÜV SÜD
    - EC Type-Examination certificate:  
EU Machinery Directive, Type 4 ESPE (EN61496-1), Type 4 AOPD (EN 61496-2)
    - Certificate:  
Type 4 ESPE (EN61496-1), Type 4 AOPD (EN61496-2), EN 61508-1 through -4 (SIL 3), EN ISO 13849-1:2015 (PL e, Category 4)
  - (2) UL
    - UL Listing:  
Type 4 and ESPE (UL61496-1), Type 4 AOPD (UL61496-2), UL508, UL1998, CAN/CSA C22.2 No.14, CAN/CSA C22.2 No.0.8
6. Other Standards  
The F3SG-RR is designed according to the standards listed below. To make sure that the final system complies with the following standards and regulations, you are asked to design and use it in accordance with all other related standards, laws, and regulations. If you have any questions, consult with specialized organizations such as the body responsible for prescribing and/or enforcing machinery safety regulations in the location where the equipment is to be used.
  - European Standards: EN415-4, EN691-1, EN692, EN693, IEC 62046
  - U.S. Occupational Safety and Health Standards: OSHA 29 CFR 1910.212
  - U.S. Occupational Safety and Health Standards: OSHA 29 CFR 1910.217
  - American National Standards: ANSI B11.1 to B11.19
  - American National Standards: ANSI/RIA R15.06
  - Canadian Standards Association CSA Z142, Z432, Z434
  - SEMI Standards SEMI S2
  - Japan Ministry of Health, Labour and Welfare "Guidelines for Comprehensive Safety Standards of Machinery", Standard Bureau's Notification No. 0731001 dated July 31, 2007.rms and Conditions Agreement

# F3SG-RR

## Indicator

### Emitter

Name of Indicator		Color	Illuminated	Blinking
Test	TEST	Green	–	External Test is being performed
Operating range	LONG	Green	Always illuminated	Lockout state due to Scan code setting error
Power	POWER	Green	Power is ON.	Error due to noise
Lockout	LOCKOUT	Red	–	Lockout state due to error in emitter

### Receiver

Name of Indicator		Color	Illuminated	Blinking
Top-beam-state	TOP	Blue	The top beam is unblocked	Muting/Override state, or Lockout state due to Cap error or Other sensor error
PNP/NPN mode	NPN	Green	NPN mode is selected	–
Response time	SLOW	Green	Response Time Adjustment is enabled	–
Sequence error	SEQ	Yellow	–	Sequence error in Muting or Pre-reset mode
Blanking	BLANK	Green	Blanking, Warning Zone or Reduced Resolution is enabled	Blanking Monitoring error
Configuration	CFG	Green	–	Zone measurement being performed by Dynamic Muting, or Lockout state due to Parameter error or Cascading Configuration error
Interlock	INT-LK	Yellow	Interlock state	Pre-reset mode *2
External device monitoring	EDM	Green	RESET input is in ON state *1	Lockout state due to EDM error
Internal error	INTERNAL	Red	–	Lockout state due to Internal error, or error due to abnormal power supply or noise
Lockout	LOCKOUT	Red	–	Lockout state due to error in receiver
Stable-state	STB	Green	Incident light level is 170% or higher of ON-threshold	Safety output is instantaneously turned OFF due to ambient light or vibration
ON/OFF	ON/OFF	Green	Safety output is in ON state	–
		Red	Safety output is in OFF state	Lockout state due to Safety Output error, or error due to abnormal power supply or noise
Communication	COM	Green	Synchronization between emitter and receiver is maintained	Lockout state due to Communication error, or error due to abnormal power supply or noise
Bottom-beam-state	BTM	Blue	The bottom beam is unblocked	Muting/Override state, or Lockout state due to Scan code setting error

**Note:** TOP, CFG, LOCKOUT, STB and ON/OFF indicators are illuminated when the receiver of the F3SG-RR is in Setting mode.

\*1. The EDM indicator is illuminated when the EDM input is in the ON state regardless of the use of the EDM function.

\*2. Refer to *Safety Light Curtain F3SG-□RR Series User's Manual (ManNo.: Z383)* for more information of blinking patterns.

### Interface Unit

<b>Main Unit</b>	PC/AT compatible machine (computer that runs Microsoft Windows)
<b>Operating System (OS)</b>	Windows 7 (32-bit/64-bit), Windows 8, 8.1 (32-bit/64-bit), Windows 10 (32-bit/64-bit)
<b>Communication Port</b>	USB port ×1
<b>Ambient Temperature</b>	Operating: -10 to 55°C, Storage: -30 to 70°C (non-icing and non-condensing)
<b>Ambient Humidity</b>	Operating: 35% to 85%, Storage: 35% to 95% (non-condensing)

### Lamp

Item	F39-LP
<b>Applicable Sensor</b>	F3SG-□RA/RR Series Safety Light Curtain (Receiver)
<b>LED Light Color</b>	Red/Green/Orange
<b>Power Supply Voltage</b>	24 VDC±20%, ripple p-p 10% max. (shares sensor's power supply)
<b>Current Consumption</b>	25 mA max. (shares sensor's power supply.)
<b>Ambient Temperature</b>	Operating: -10 to 55°C, Storage: -25 to 70°C
<b>Ambient Humidity</b>	Operating: 35% to 85%, Storage: 35% to 95%
<b>Vibration Resistance</b>	10 to 55 Hz, Multiple amplitude of 0.7 mm, 20 sweeps for all 3 axes
<b>Shock Resistance</b>	100 m/s <sup>2</sup> , 1000 shocks for all 3 axes
<b>Degree of Protection</b>	IP65 and IP67 (When attached to F3SG)
<b>Type of Connection</b>	Connectable to F3SG-RA/RR's terminal connector
<b>Material</b>	Lighting element: PC, Other body parts: PBT
<b>Weight</b>	45 g (when packaged)

## Connections (Basic Wiring Diagram)

### Standalone F3SG-RR using PNP Outputs

#### Auto Reset Mode, EDM enabled and PNP Outputs

The following is the example of Muting not used, External Device Monitoring enabled, Auto Reset Mode, PNP outputs and External Test in 24 V Active (not used).

#### Settings

	Function
Receiver	EDM Enabled (factory default setting) *1
	Auto Reset (factory default setting) *1
	PNP (factory default setting) *1
Emitter	External Test: 24 V Active (End Cap: Black) (factory default setting)

#### Wiring Example

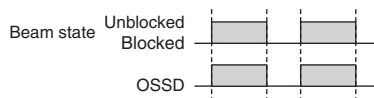
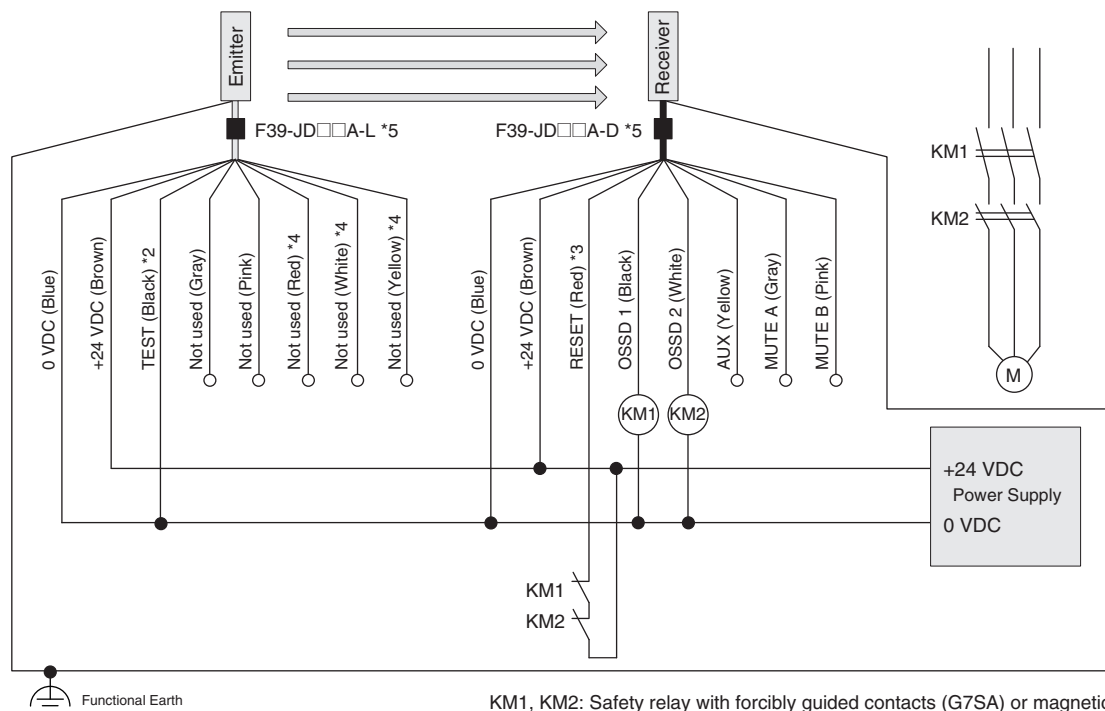

KM1, KM2: Safety relay with forcibly guided contacts (G7SA) or magnetic contactor  
M: Motor

- \*1. The functions are configurable with Configuration Tool. Refer to *Safety Light Curtain Configuration Tool for Model F3SG (SD Manager 2) User's Manual* for more information on setting the functions by the Configuration Tool.
- \*2. Connect the line to 24 V via a test switch (N.O. contact) if External Test is used.
- \*3. Also used as EDM input line. Connect a lockout reset switch (NC contact) to this line in series with the KM1 and KM2 if Lockout Reset is used.
- \*4. The F39-JD□□RA-L Single-Ended Cable for Emitter (Oil-Resistant Cable) does not have the red, white and yellow wires.
- \*5. For the F39-JD□□A-□ Single-Ended Cable, connect the shield line to 0 V.

**Note:** Functional earth connection is unnecessary when you use the F3SG-RR in a general industrial environment where noise control or stable power supply is considered. However, when you use the F3SG-RR in an environment where there may be excessive noise from surroundings or stable power supply may be interfered, it is recommended the F3SG-RR be connected to functional earth.

The wiring examples in later examples do not indicate functional earth. To use functional earth, wire an earth cable according to the example above. Refer to *Safety Light Curtain F3SG-RR Series User's Manual* for more information.

## Standalone F3SG-RR using NPN Outputs

### Auto Reset Mode, EDM enabled and NPN Outputs

The following is the example of Muting not used, External Device Monitoring enabled, Auto Reset Mode, NPN outputs and External Test in 0 V Active (not used).

### Settings

	Function
Receiver	EDM Enabled (factory default setting) *1
	Auto Reset (factory default setting) *1
	NPN *1
Emitter	External Test: 0 V Active (End Cap: White)

### Wiring Example

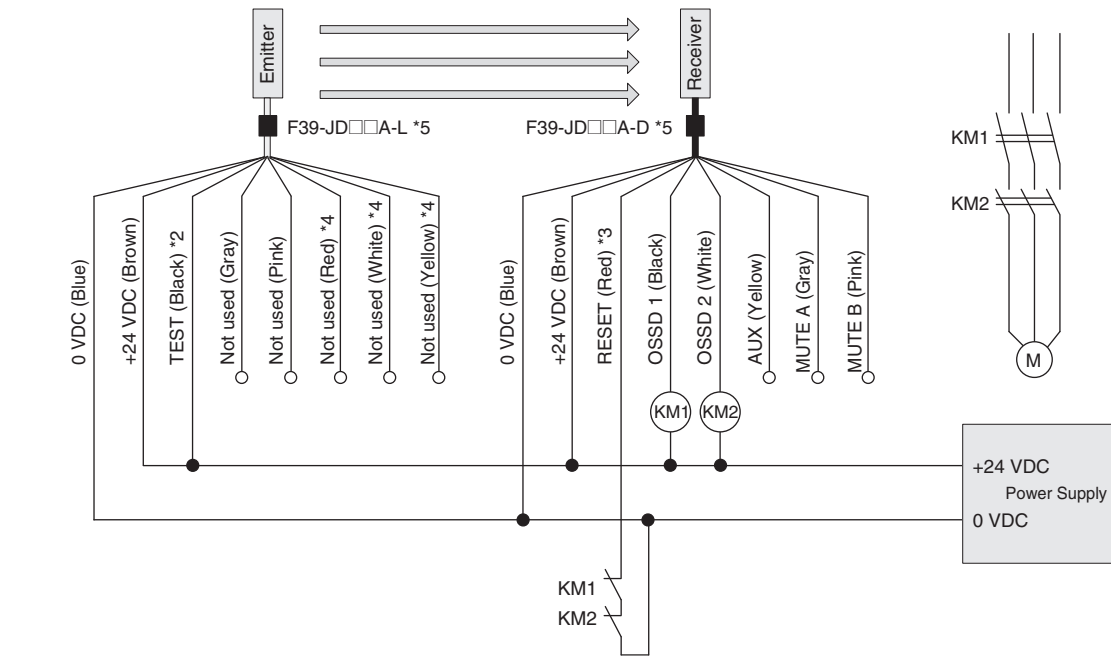

KM1, KM2: Safety relay with forcibly guided contacts (G7SA)  
M: Motor

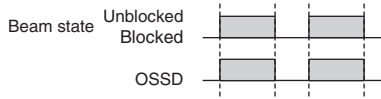

\*1. The functions are configurable with Configuration Tool. Refer to *Safety Light Curtain Configuration Tool for Model F3SG (SD Manager 2) User's Manual* for more information on setting the functions by the Configuration Tool.

\*2. Connect the line to 0 V via a test switch (N.O. contact) if External Test is used.

\*3. Also used as EDM input line. Connect a lockout reset switch (NC contact) to this line in series with the KM1 and KM2 if Lockout Reset is used.

\*4. The F39-JD□□RA-L Single-Ended Cable for Emitter (Oil-Resistant Cable) does not have the red, white and yellow wires.

\*5. For the F39-JD□□A-□ Single-Ended Cable, connect the shield line to 0 V.

**Note:** For the functional earth connection, refer to page 55.

## Connectable Safety Control Units

The F3SG-RR with PNP output can be connected to the safety control units listed in the table below.

Connectable Safety Control Units (PNP output)		
Safety Relay Units	Flexible Safety Units	Safety Controllers
G9SA-301		G9SP-N10S
G9SA-321-T□		G9SP-N10D
G9SA-501		G9SP-N20S
G9SB-200-B	G9SX-AD322-T	NE0A-SCPU01
G9SB-200-D	G9SX-ADA222-T	NE1A-SCPU01
G9SB-301-B	G9SX-BC202	NE1A-SCPU02
G9SB-301-D	G9SX-GS226-T15	DST1-ID12SL-1
G9SE-201		DST1-MD16SL-1
G9SE-401		DST1-MRD08SL-1
G9SE-221-T□		NX-SIH400
		NX-SID800
		F3SP-T01

The F3SG-R with NPN output can be connected to the safety control units listed in the table below.

Connectable Safety Control Units (NPN output)
Safety Relay Units
G9SA-301-P

# F3SG-RR

## Input/Output Circuit

### Entire Circuit Diagram

The entire circuit diagram of the F3SG-RR is shown below.

The numbers in the circles indicate the connector's pin numbers.

### PNP Output

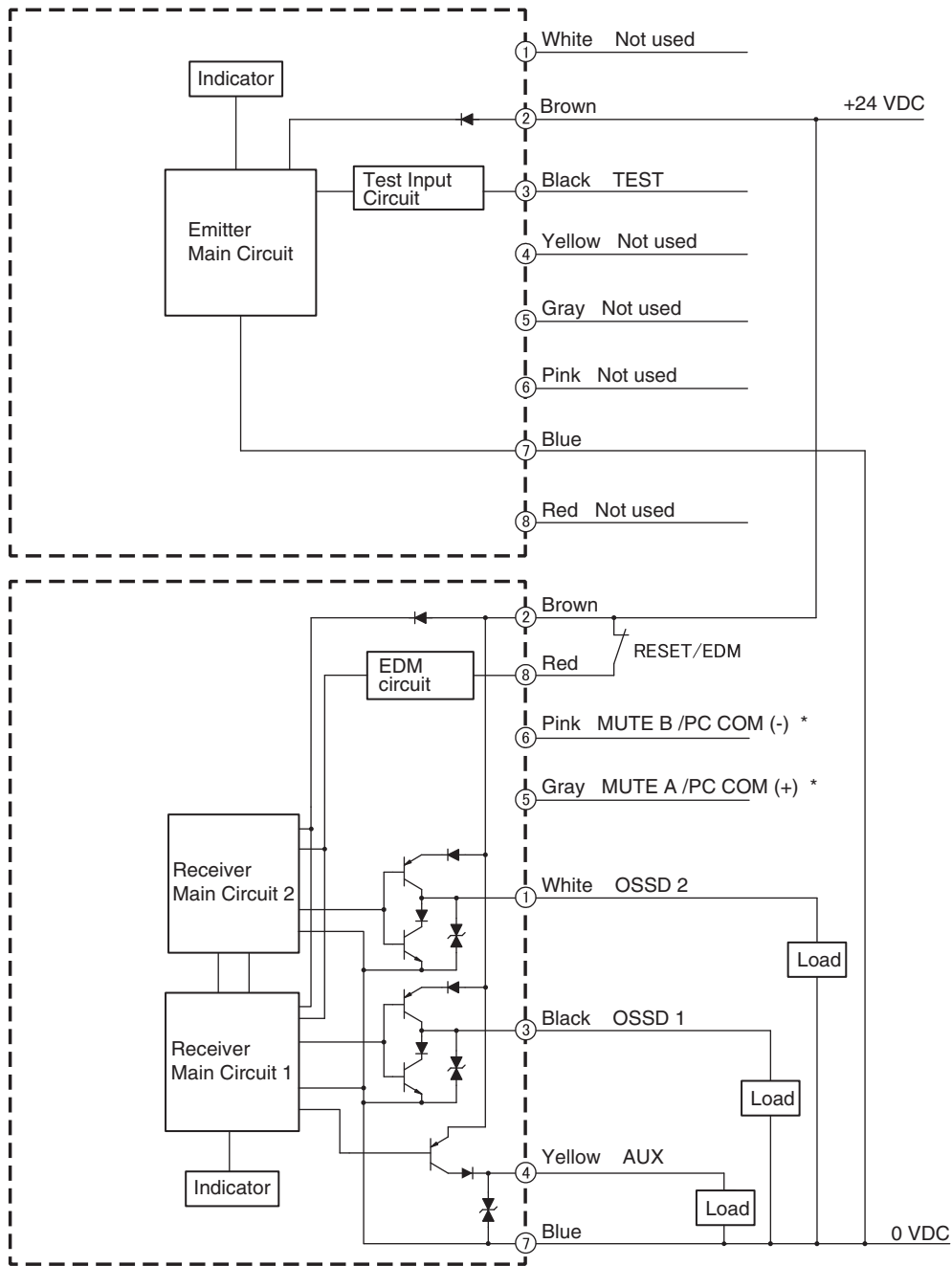

\* This line is used for communication with a PC using the F39-GIF-1 Interface Unit.

NPN Output

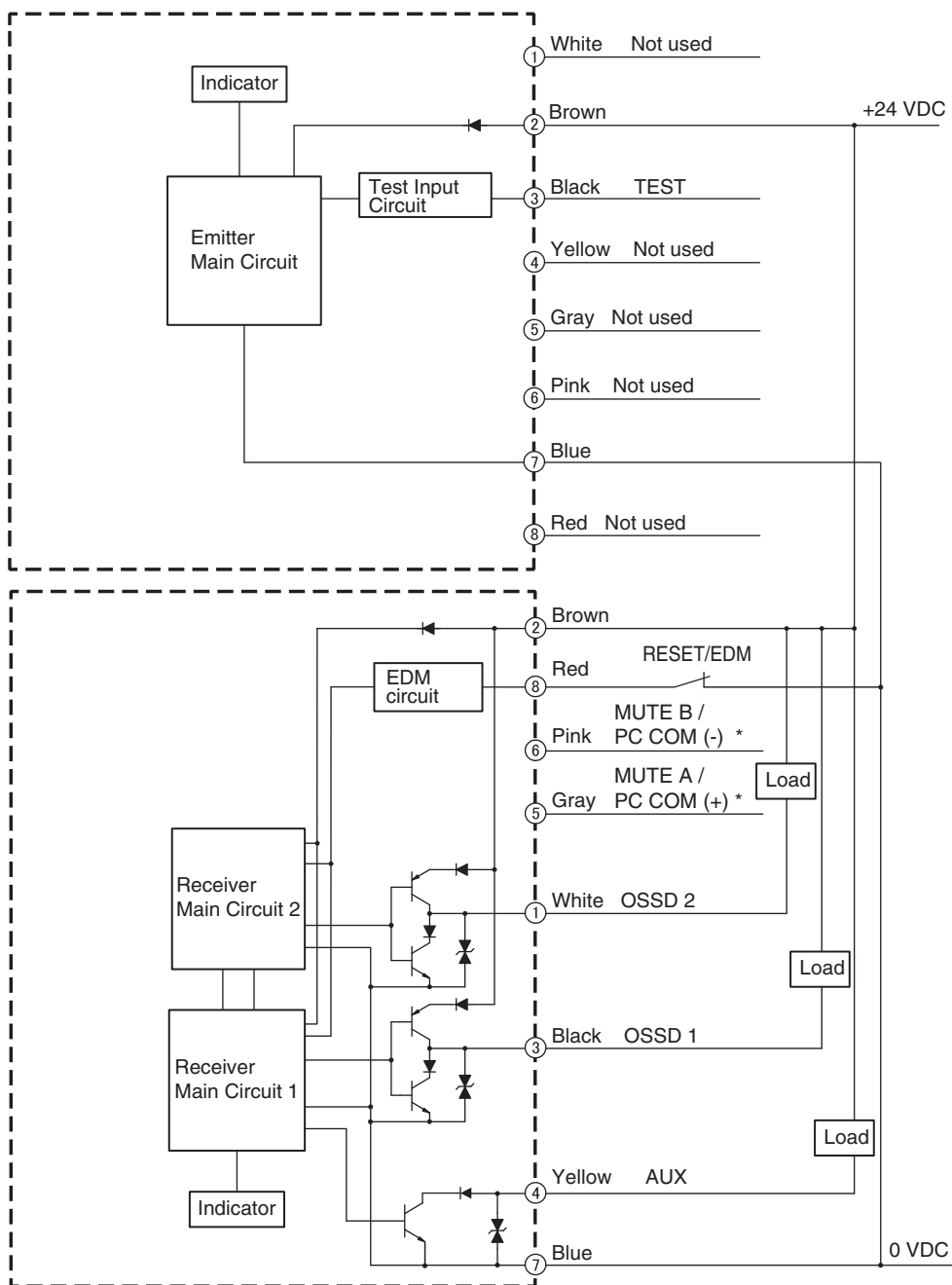

\* This line is used for communication with a PC using the F39-GIF-1 Interface Unit.

F3SG-RR

## Input Circuit Diagram by Function

The input circuit diagrams of by function are shown below.

### TEST

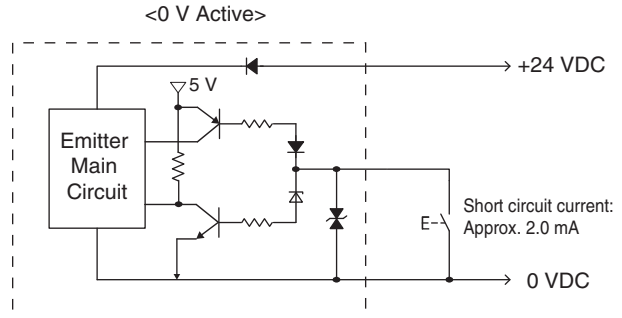
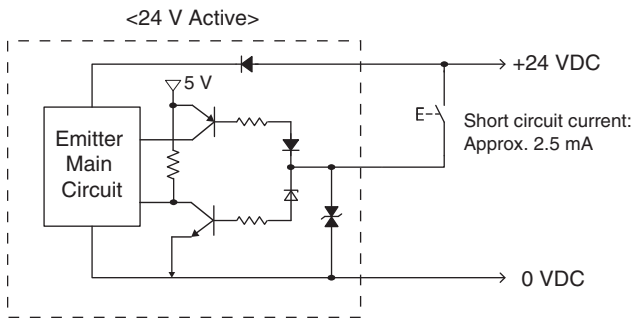

### RESET/EDM, MUTE A/B

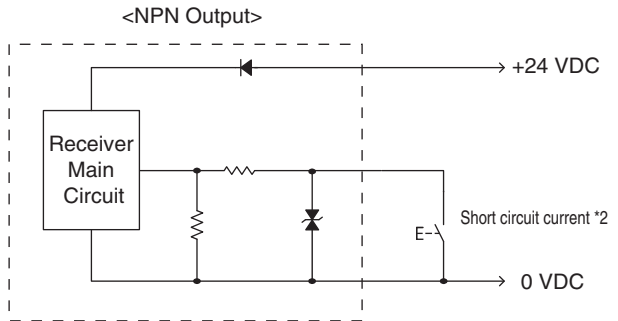
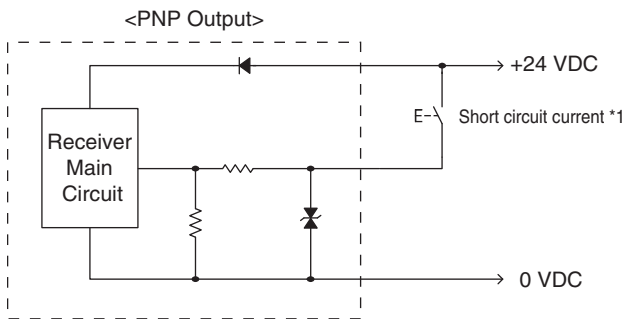

\*1. Short circuit current: approx. 6.5 mA (RESET/EDM), approx. 3.0 mA (MUTE A/B)

\*2. Short circuit current: approx. 8.0 mA (RESET/EDM), approx. 5.0 mA (MUTE A/B)

# Dimensions

## Mounted with Free-Location Brackets (F39-LGRA) Backside Mounting

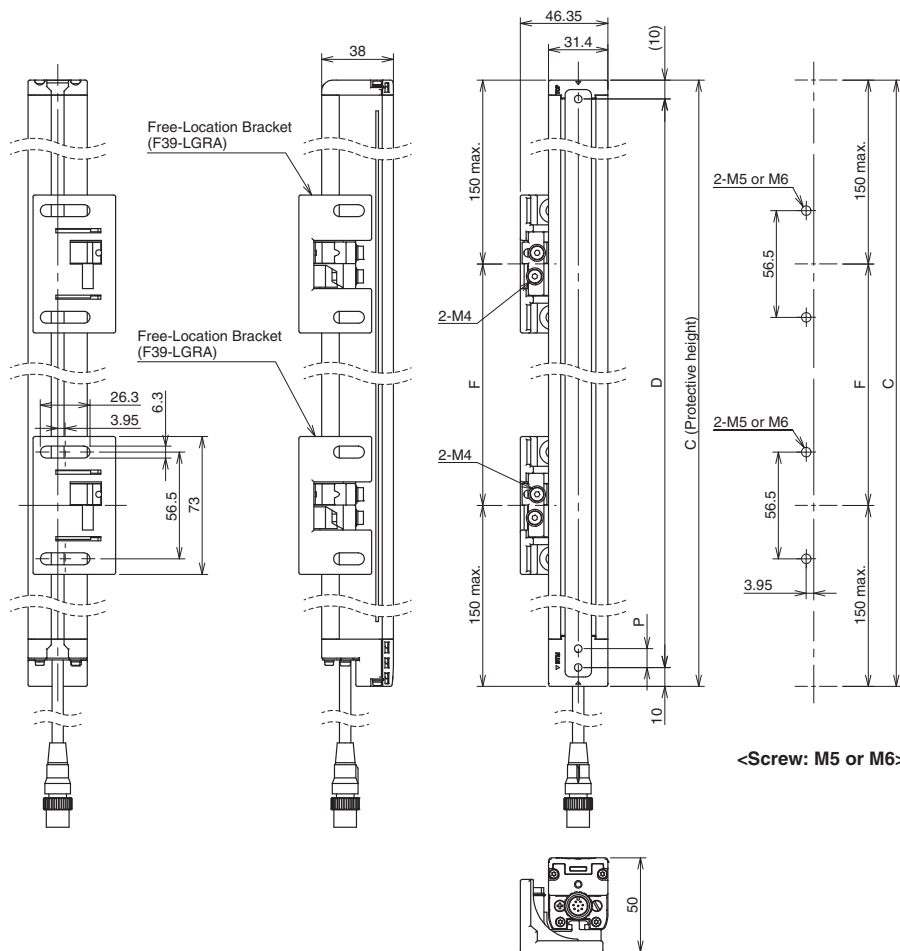

<b>Dimension C</b>	4-digit number of the type name (Protective height)	
<b>Dimension D</b>	C-20	
<b>Dimension P</b>	F3SG-4RR□□□□-14	10
	F3SG-4RR□□□□-25	20

Protective height (C)	Number of Free-Location Brackets *1	Dimension F
0240 to 1200	2 *2	1000 mm max.
1280 to 1920	3	1000 mm max.

\*1. The number of brackets required to mount either one of emitter and receiver.

\*2. Mounting an emitter or receiver with one bracket is possible for the model of protective height of 0240. In this case, locate this bracket at half the Dimension C (or at the center of the sensor length).

F3SG-RR

## Side Mounting

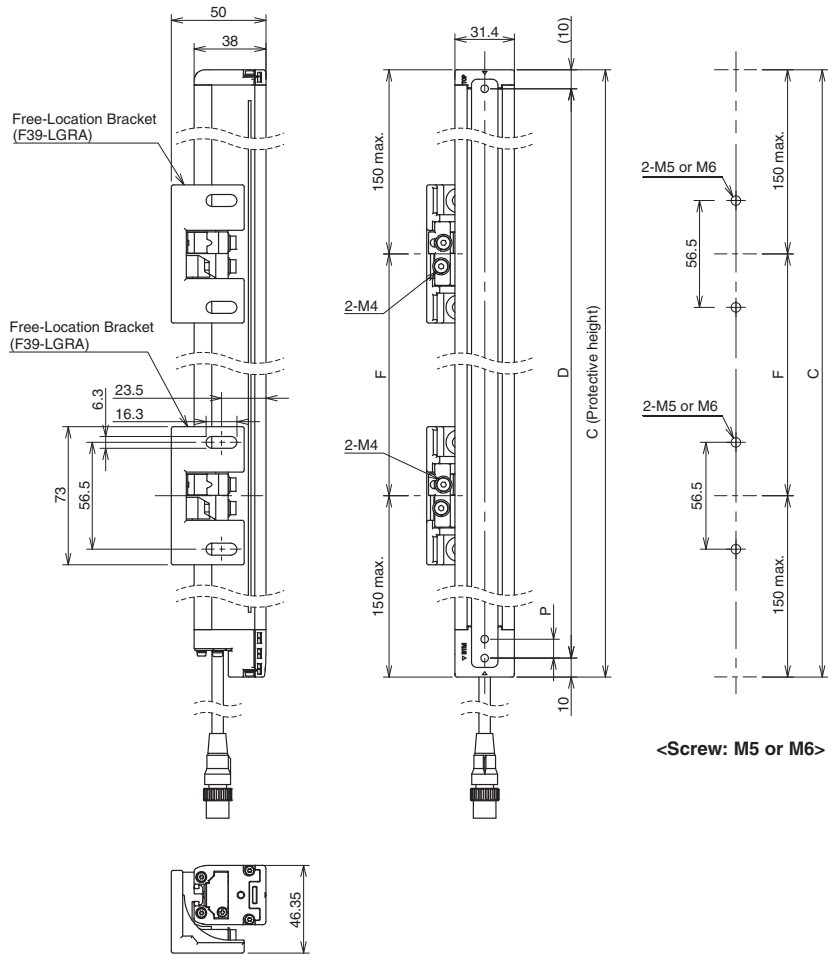

<b>Dimension C</b>	4-digit number of the type name (Protective height)	
<b>Dimension D</b>	C-20	
<b>Dimension P</b>	F3SG-4RR□□□□-14	10
	F3SG-4RR□□□□-25	20

Protective height (C)	Number of Free-Location Brackets *1	Dimension F
0240 to 1200	2 *2	1000 mm max.
1280 to 1920	3	1000 mm max.

\*1. The number of brackets required to mount either one of emitter and receiver.

\*2. Mounting an emitter or receiver with one bracket is possible for the model of protective height of 0240. In this case, locate this bracket at half the Dimension C (or at the center of the sensor length).





### Mounted with Top/Bottom Brackets (F39-LGRTB-2) and Intermediate Bracket (F39-LGRA) Backside Mounting

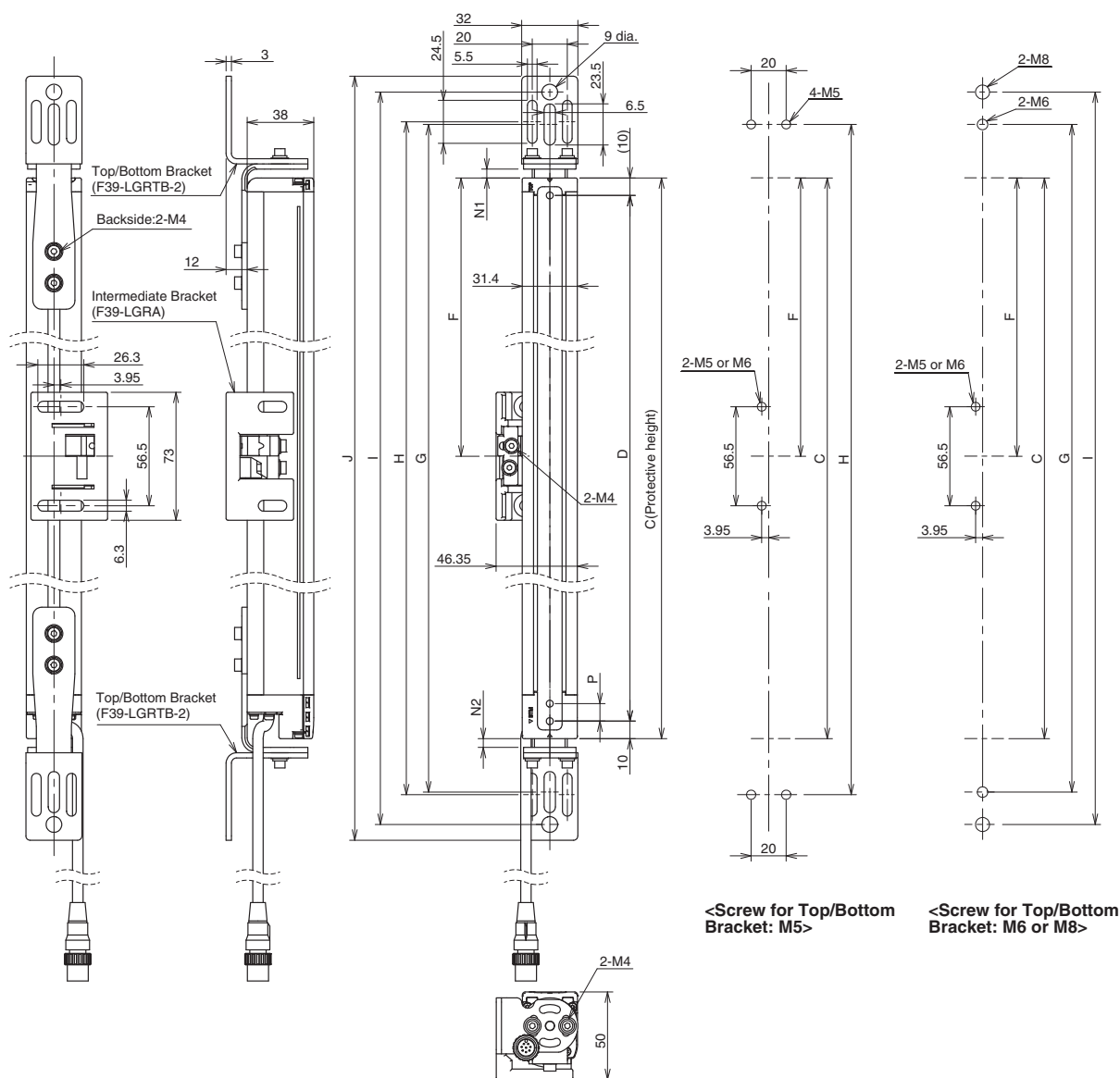

<Screw for Top/Bottom Bracket: M5>

<Screw for Top/Bottom Bracket: M6 or M8>

<b>Dimension C</b>	4-digit number of the type name (Protective height)	
<b>Dimension D</b>	C-20	
<b>Dimension G</b>	C+51+N1+N2	
<b>Dimension H</b>	C+54+N1+N2	
<b>Dimension I</b>	C+88+N1+N2	
<b>Dimension J</b>	C+106+N1+N2	
<b>Dimension N1</b>	0 to 30	
<b>Dimension N2</b>	0 to 13	
<b>Dimension P</b>	F3SG-4RR□□□□-14	10
	F3SG-4RR□□□□-25	20

Protective height (C)	Number of Top/Bottom Brackets *	Number of Intermediate Brackets *	Dimension F
0240 to 1040	2	0	-
1120 to 1920	2	1	1000 mm max.

\* The number of brackets required to mount either one of emitter and receiver.

F3SG-RR

## Side Mounting

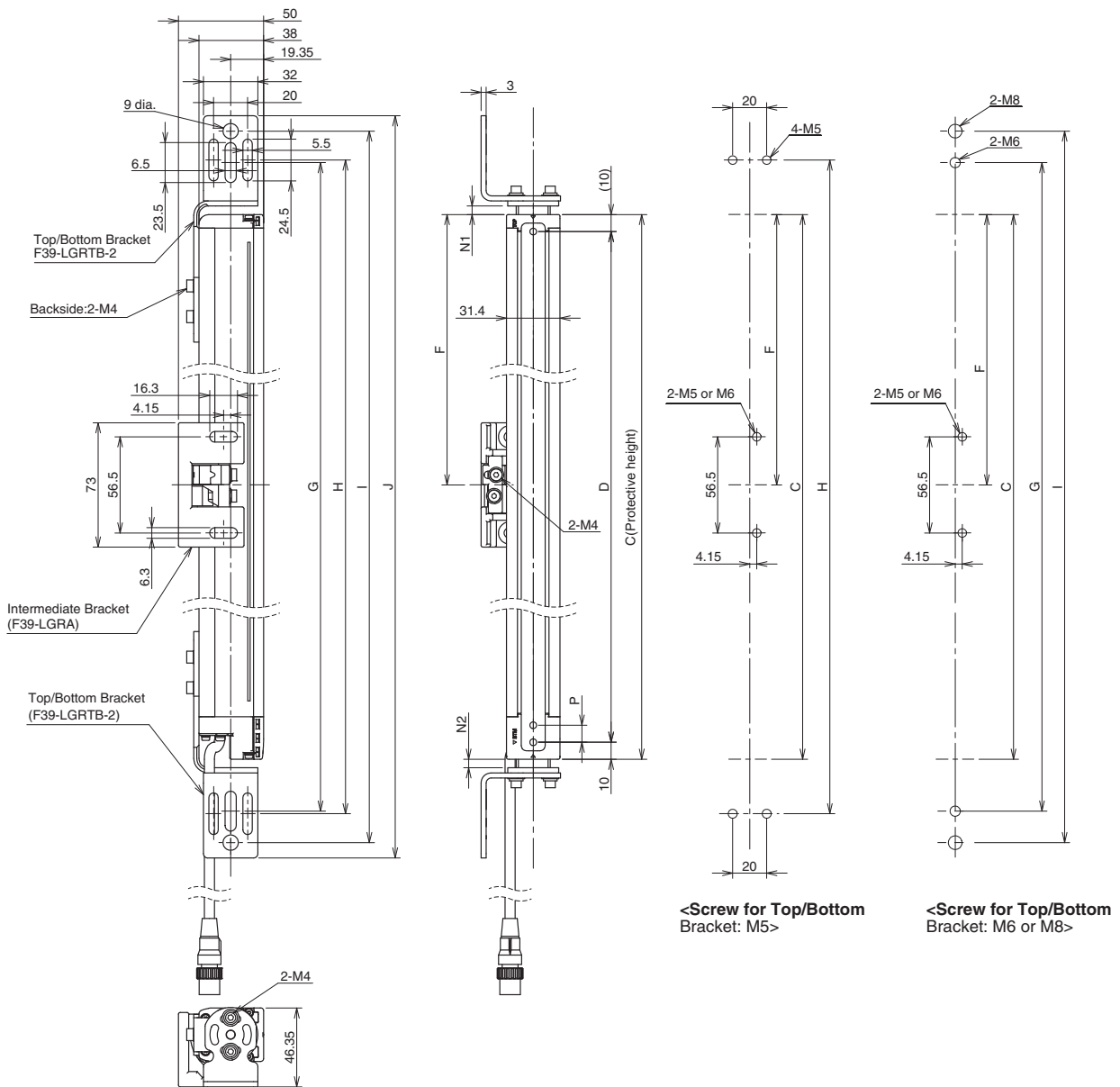

<b>Dimension C</b>	4-digit number of the type name (Protective height)	
<b>Dimension D</b>	C-20	
<b>Dimension G</b>	C+51+N1+N2	
<b>Dimension H</b>	C+54+N1+N2	
<b>Dimension I</b>	C+88+N1+N2	
<b>Dimension J</b>	C+106+N1+N2	
<b>Dimension N1</b>	0 to 30	
<b>Dimension N2</b>	0 to 13	
<b>Dimension P</b>	F3SG-4RR□□□□-14	10
	F3SG-4RR□□□□-25	20

Protective height (C)	Number of Top/Bottom Brackets *	Number of Intermediate Brackets *	Dimension F
0240 to 1040	2	0	-
1120 to 1920	2	1	1000 mm max.

\* The number of brackets required to mount either one of emitter and receiver.

**Mounted with Top/Bottom Brackets (F39-LGRTB-3) and Intermediate Bracket (F39-LGRA)  
Backside Mounting**

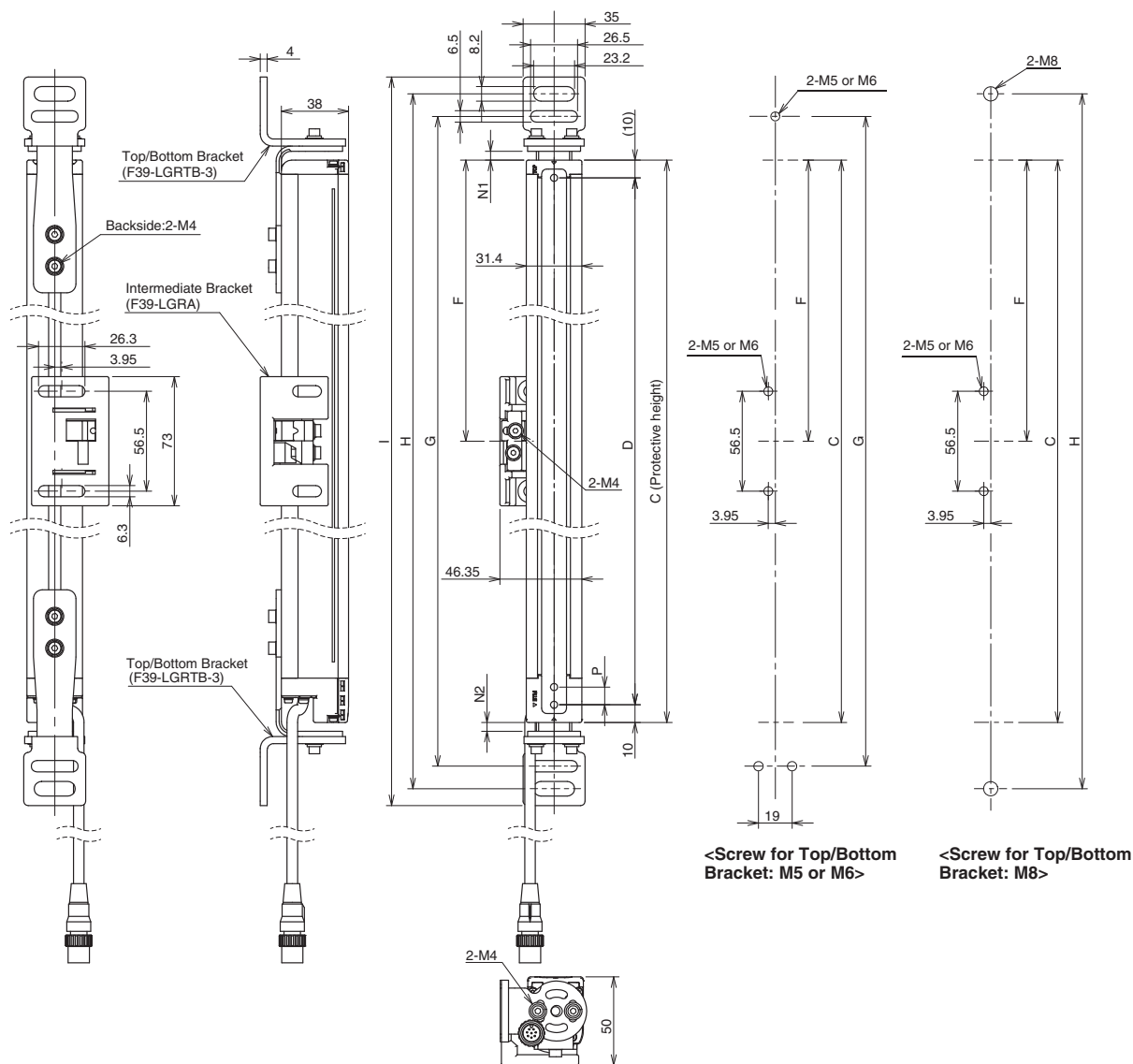

<b>Dimension C</b>	4-digit number of the type name (Protective height)	
<b>Dimension D</b>	C-20	
<b>Dimension G</b>	C+39.5+N1+N2	
<b>Dimension H</b>	C+65+N1+N2	
<b>Dimension I</b>	C+84+N1+N2	
<b>Dimension N1</b>	0 to 30	
<b>Dimension N2</b>	0 to 13	
<b>Dimension P</b>	F3SG-4RR□□□□-14	10
	F3SG-4RR□□□□-25	20

Protective height (C)	Number of Top/Bottom Brackets *	Number of Intermediate Brackets *	Dimension F
0240 to 1040	2	0	-
1120 to 1920	2	1	1000 mm max.

\* The number of brackets required to mount either one of emitter and receiver.

F3SG-RR

## Side Mounting

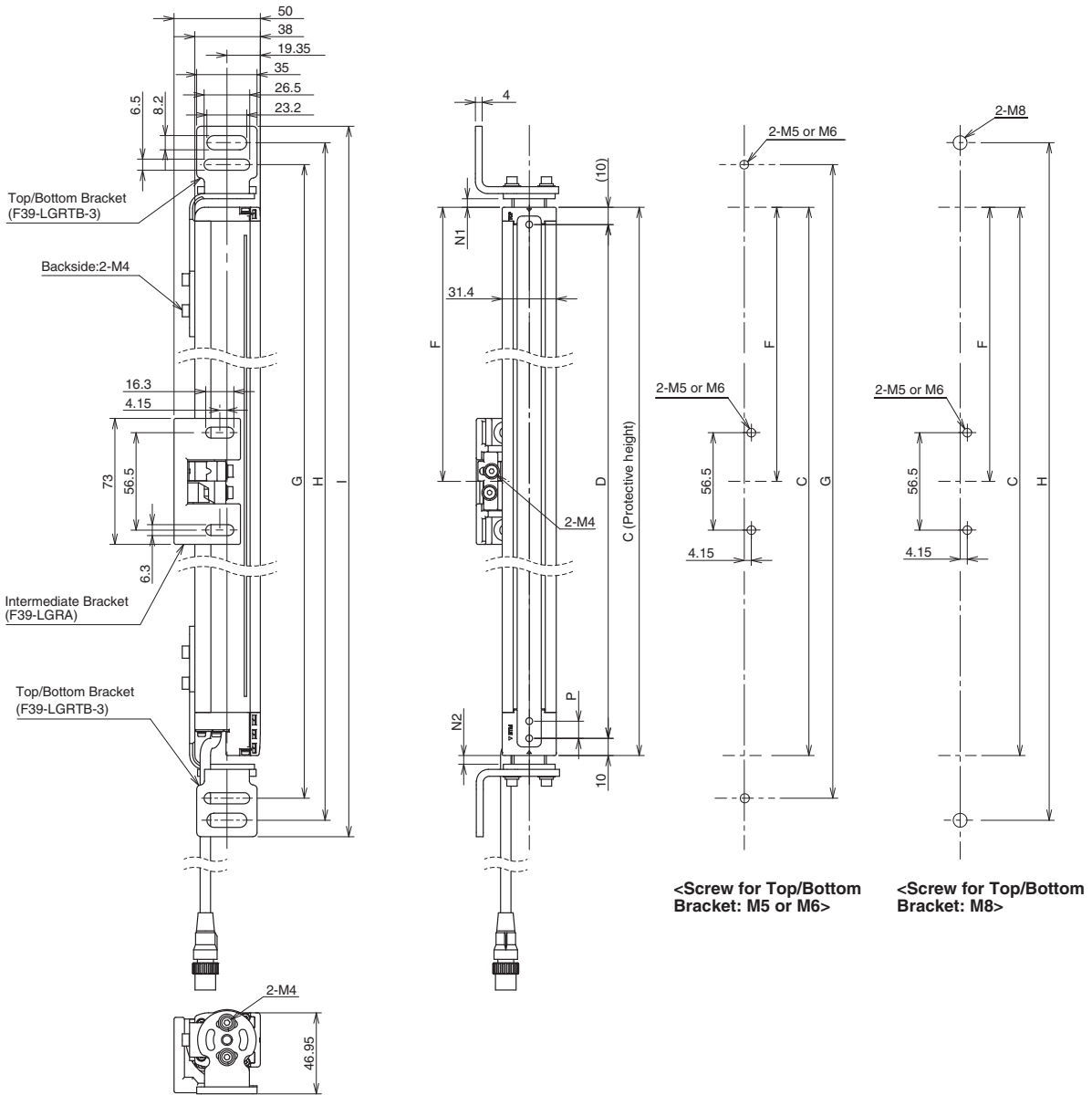

<b>Dimension C</b>	4-digit number of the type name (Protective height)	
<b>Dimension D</b>	C-20	
<b>Dimension G</b>	$C+39.5+N1+N2$	
<b>Dimension H</b>	$C+65+N1+N2$	
<b>Dimension I</b>	$C+84+N1+N2$	
<b>Dimension N1</b>	0 to 30	
<b>Dimension N2</b>	0 to 13	
<b>Dimension P</b>	F3SG-4RR□□□□-14	10
	F3SG-4RR□□□□-25	20

Protective height (C)	Number of Top/Bottom Brackets *	Number of Intermediate Brackets *	Dimension F
0240 to 1040	2	0	—
1120 to 1920	2	1	1000 mm max.

\* The number of brackets required to mount either one of emitter and receiver.

## Accessories

### Sensor Mounting Brackets Free-Location Bracket / Intermediate Bracket (F39-LGRA, sold separately)

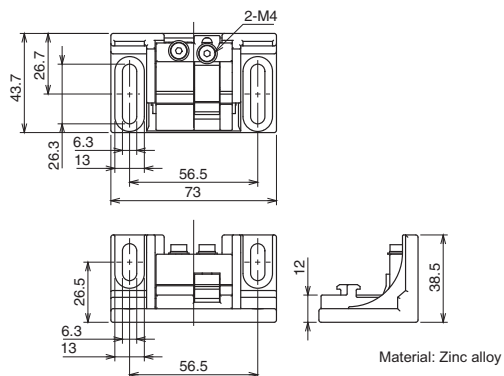

### Top/Bottom Bracket (F39-LGRTB, sold separately)

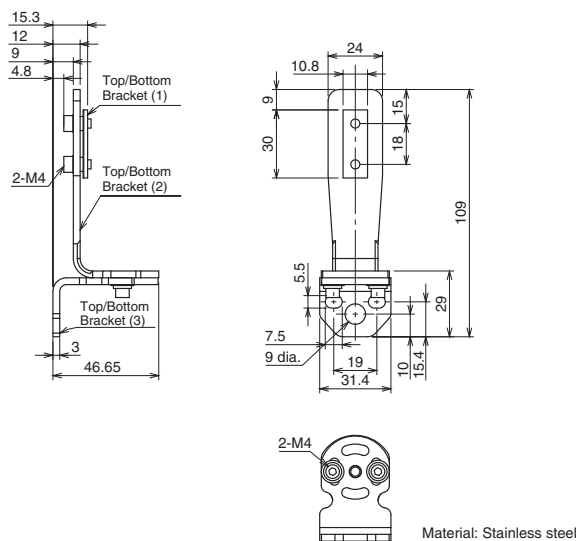

### Top/Bottom Bracket (F39-LGRTB-2, sold separately)

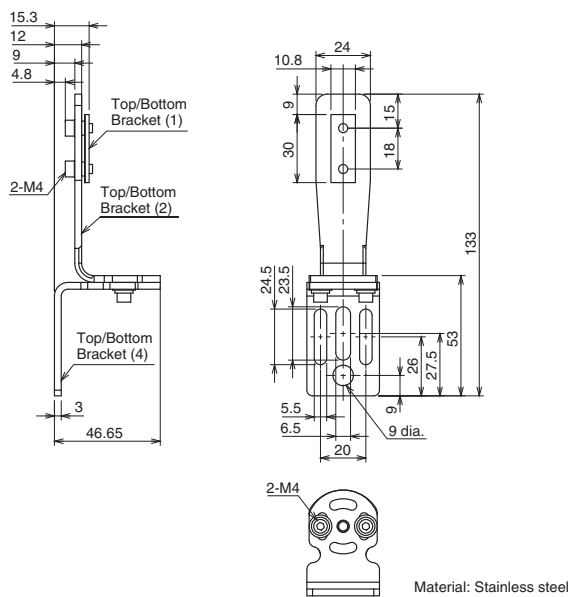

### Top/Bottom Bracket (F39-LGRTB-3, sold separately)

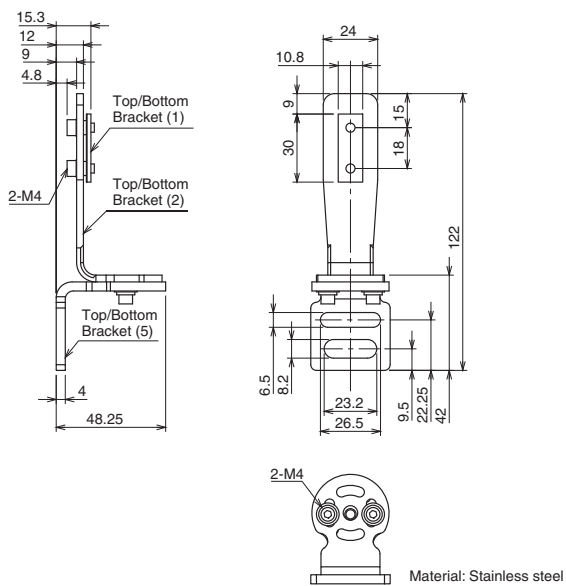

F3SG-RR

# F3SG-RR

## Safety light curtain connecting cable

### Single-Ended Cable for Emitter (Oil-Resistant Cable) (F39-JD□RA-L, sold separately)

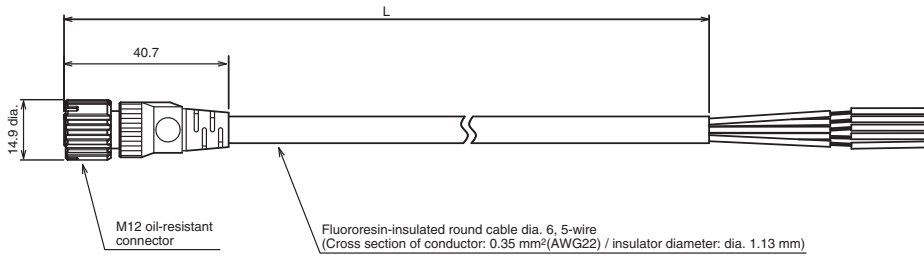

### Single-Ended Cable for Receiver (Oil-Resistant Cable) (F39-JD□RA-D, sold separately)

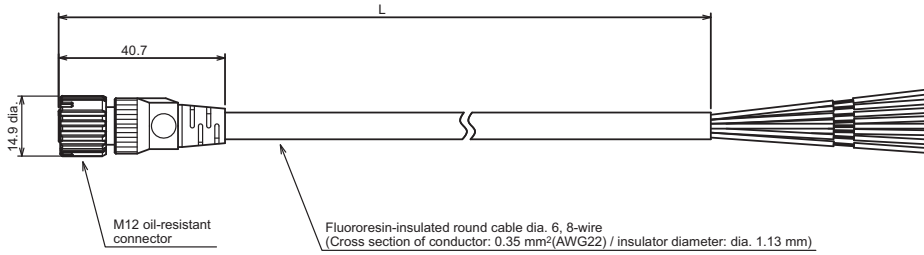

Emitter cable (Gray)	Receiver cable (Black)	L (m)
F39-JD3RA-L	F39-JD3RA-D	3
F39-JD7RA-L	F39-JD7RA-D	7

### Single-Ended Cable for Emitter (F39-JD□A-L, sold separately)

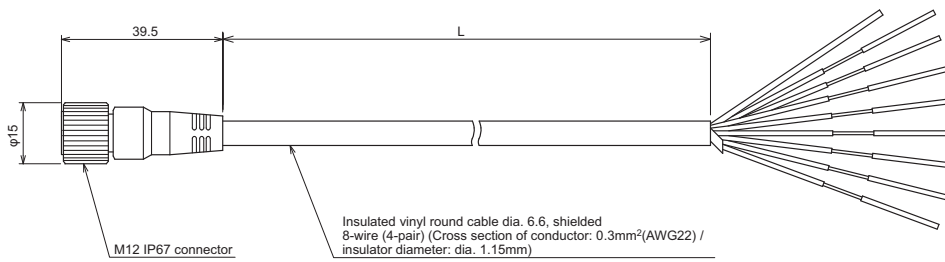

### Single-Ended Cable for Receiver (F39-JD□A-D, sold separately)

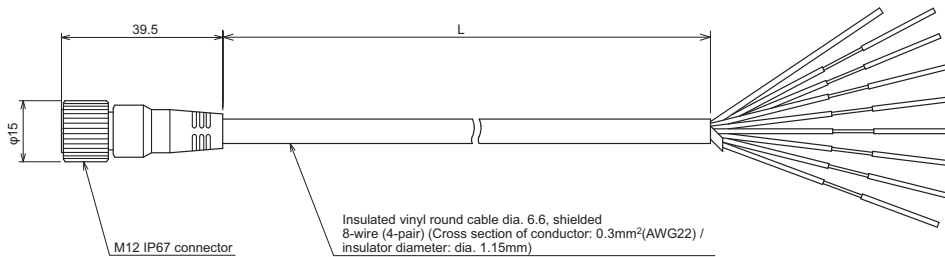

Emitter cable (Gray)	Receiver cable (Black)	L (m)
F39-JD3A-L	F39-JD3A-D	3
F39-JD7A-L	F39-JD7A-D	7
F39-JD10A-L	F39-JD10A-D	10
F39-JD15A-L	F39-JD15A-D	15
F39-JD20A-L	F39-JD20A-D	20

### Double-Ended Cable for Emitter: Cable for extension (F39-JD□B-L, sold separately)

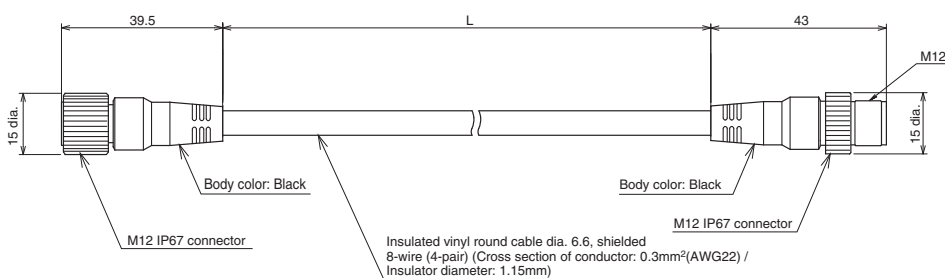

**Double-Ended Cable for Receiver: Cable for extension (F39-JD□B-D, sold separately)**

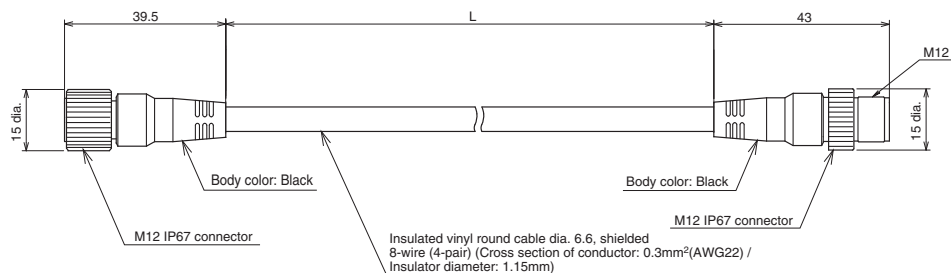

Emitter cable (Gray)	Receiver cable (Black)	L (m)
F39-JDR5B-L	F39-JDR5B-D	0.5
F39-JD1B-L	F39-JD1B-D	1
F39-JD3B-L	F39-JD3B-D	3
F39-JD5B-L	F39-JD5B-D	5
F39-JD7B-L	F39-JD7B-D	7
F39-JD10B-L	F39-JD10B-D	10
F39-JD15B-L	F39-JD15B-D	15
F39-JD20B-L	F39-JD20B-D	20

**Reduced Wiring Connector (F39-CN5, sold separately)**

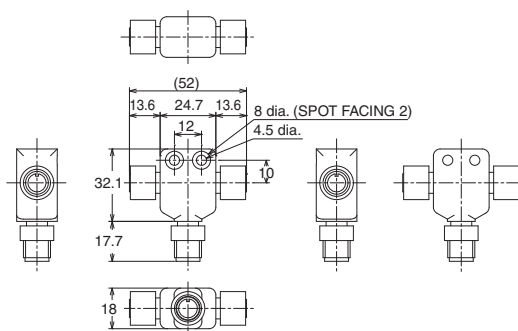

**Cascading Cable for Emitter (F39-JGR2WTS-L, sold separately)**

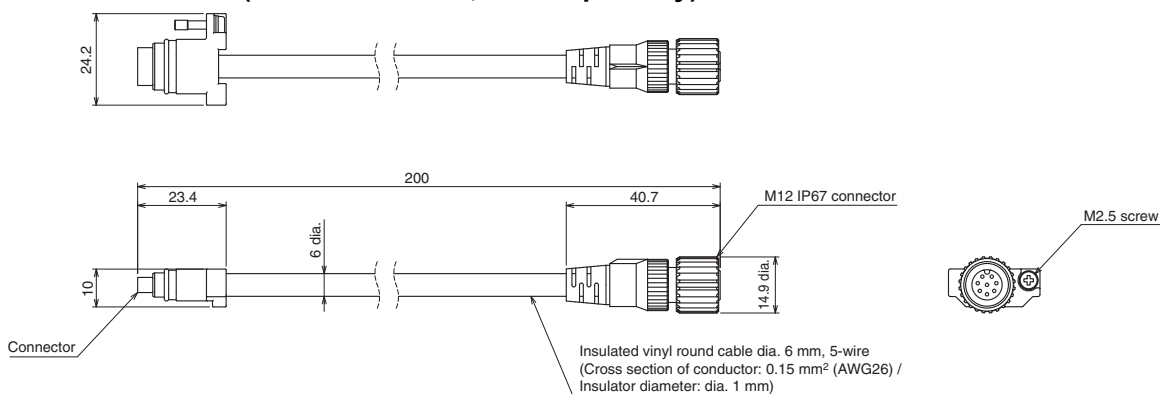

**Cascading Cable for Receiver (F39-JGR2WTS-D, sold separately)**

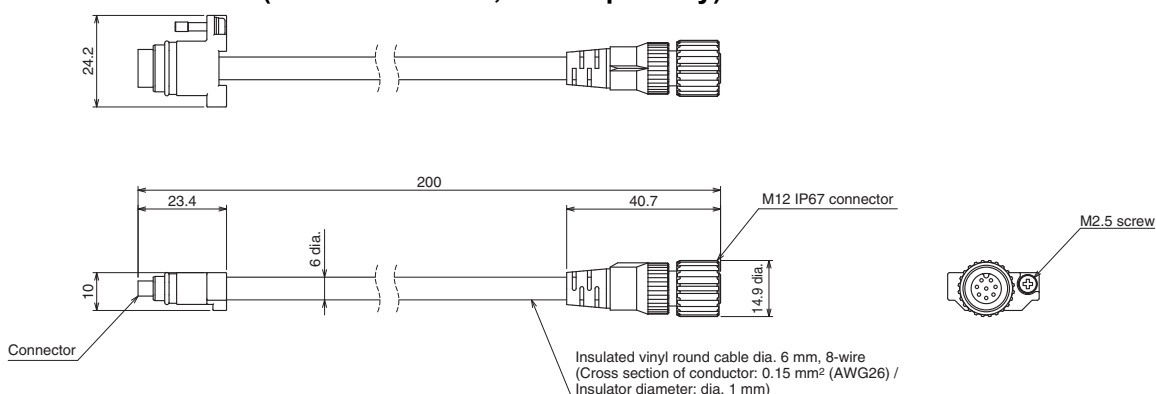

Set model name	Emitter cable (Gray)	Receiver cable (Black)	L (m)
F39-JGR2WTS	F39-JGR2WTS-L	F39-JGR2WTS-D	0.2

F3SG-RR

# F3SG-RR

## Interface Unit (F39-GIF-1, sold separately)

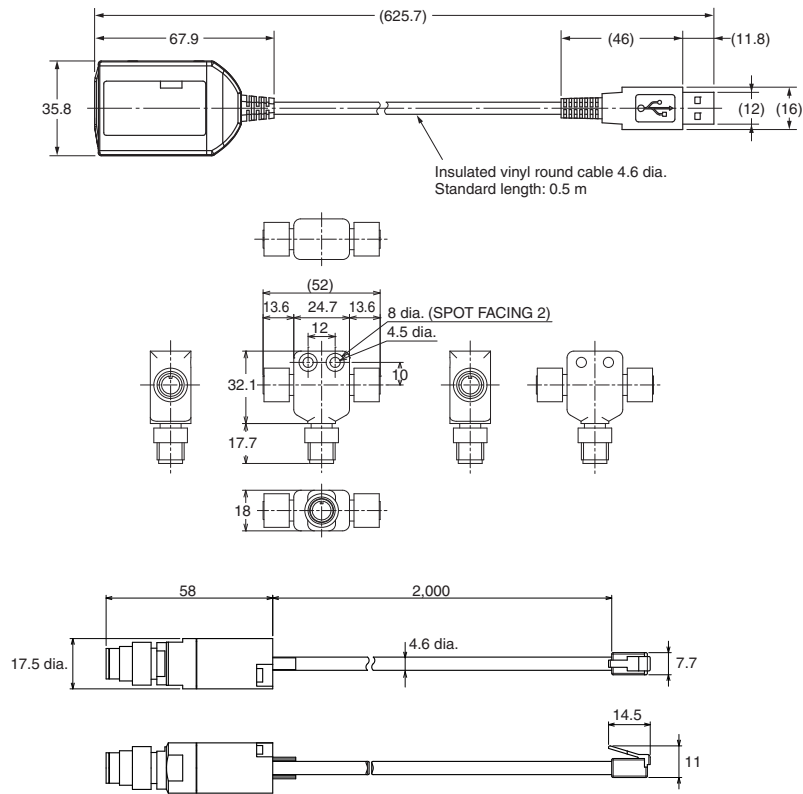

## Bluetooth Communication Unit (F39-BT, sold separately)

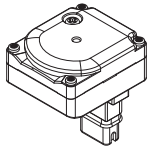

Material: PBT

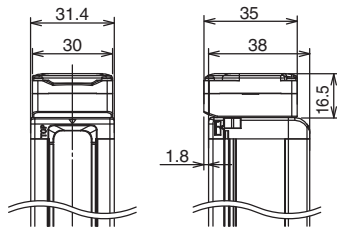

## Lamp and Bluetooth Communication Unit (F39-BTLP, sold separately) Lamp (F39-LP, sold separately)

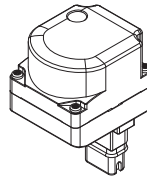

Material:  
PC (Lighting element)  
PBT (Other body parts)

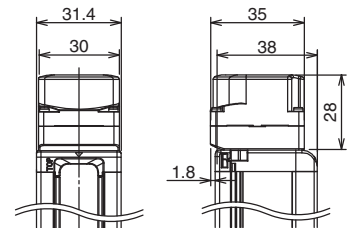

## Related Manuals

ManNo.	Model	Manual name
Z383	F3SG-□RR□□□□□□□□□□□□□□□□	Safety Light Curtain F3SG-□RR Series User's Manual

# Safety Light Curtain Easy type

# F3SG-RE



## Easy-to-use Safety Sensor Ideal for Simple On/Off Detection Applications

- Provides simple safety functions - saving TCO by reducing errors
- Simple wiring with only 4 wires
- Fast response time of 5 ms

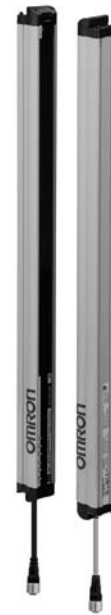

## System Configuration

### Mounting bracket



### Accessory

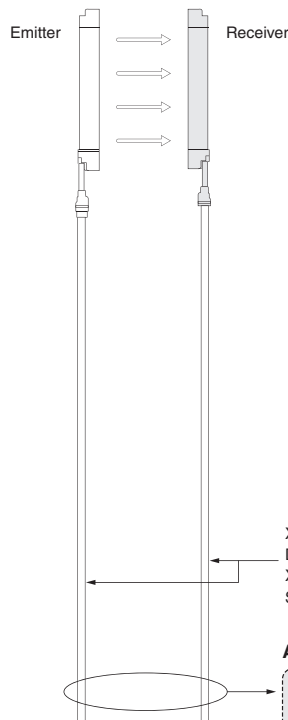

### Accessory

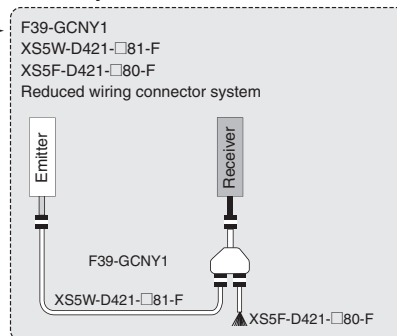

### Recommended safety controller \*

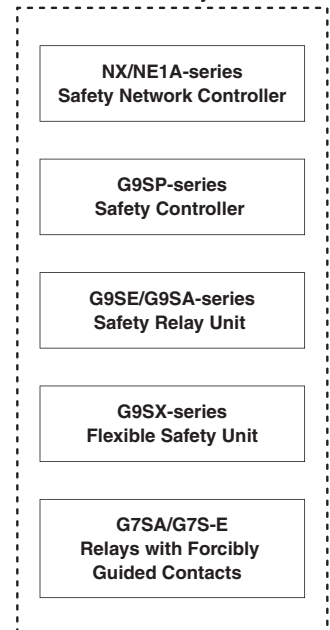

\* The recommended safety controller is required to build a safety circuit using emergency stop switches and door switches.

## Ordering Information

### Main Units

Safety Light Curtain

Finger protection

Number of beams	Protective height (mm)	Model	
		PNP output	NPN output
15	160	F3SG-4RE0160P14	F3SG-4RE0160N14
23	240	F3SG-4RE0240P14	F3SG-4RE0240N14
31	320	F3SG-4RE0320P14	F3SG-4RE0320N14
39	400	F3SG-4RE0400P14	F3SG-4RE0400N14
47	480	F3SG-4RE0480P14	F3SG-4RE0480N14
55	560	F3SG-4RE0560P14	F3SG-4RE0560N14
63	640	F3SG-4RE0640P14	F3SG-4RE0640N14
71	720	F3SG-4RE0720P14	F3SG-4RE0720N14
79	800	F3SG-4RE0800P14	F3SG-4RE0800N14
87	880	F3SG-4RE0880P14	F3SG-4RE0880N14
95	960	F3SG-4RE0960P14	F3SG-4RE0960N14
103	1,040	F3SG-4RE1040P14	F3SG-4RE1040N14
111	1,120	F3SG-4RE1120P14	F3SG-4RE1120N14
119	1,200	F3SG-4RE1200P14	F3SG-4RE1200N14
127	1,280	F3SG-4RE1280P14	F3SG-4RE1280N14
135	1,360	F3SG-4RE1360P14	F3SG-4RE1360N14
143	1,440	F3SG-4RE1440P14	F3SG-4RE1440N14
151	1,520	F3SG-4RE1520P14	F3SG-4RE1520N14
159	1,600	F3SG-4RE1600P14	F3SG-4RE1600N14
167	1,680	F3SG-4RE1680P14	F3SG-4RE1680N14
175	1,760	F3SG-4RE1760P14	F3SG-4RE1760N14
183	1,840	F3SG-4RE1840P14	F3SG-4RE1840N14
191	1,920	F3SG-4RE1920P14	F3SG-4RE1920N14
199	2,000	F3SG-4RE2000P14	F3SG-4RE2000N14
207	2,080	F3SG-4RE2080P14	F3SG-4RE2080N14



### Hand and arm protection

Number of beams	Protective height (mm)	Model	
		PNP	NPN
8	190	F3SG-4RE0190P30	F3SG-4RE0190N30
12	270	F3SG-4RE0270P30	F3SG-4RE0270N30
16	350	F3SG-4RE0350P30	F3SG-4RE0350N30
20	430	F3SG-4RE0430P30	F3SG-4RE0430N30
24	510	F3SG-4RE0510P30	F3SG-4RE0510N30
28	590	F3SG-4RE0590P30	F3SG-4RE0590N30
32	670	F3SG-4RE0670P30	F3SG-4RE0670N30
36	750	F3SG-4RE0750P30	F3SG-4RE0750N30
40	830	F3SG-4RE0830P30	F3SG-4RE0830N30
44	910	F3SG-4RE0910P30	F3SG-4RE0910N30
48	990	F3SG-4RE0990P30	F3SG-4RE0990N30
52	1,070	F3SG-4RE1070P30	F3SG-4RE1070N30
56	1,150	F3SG-4RE1150P30	F3SG-4RE1150N30
60	1,230	F3SG-4RE1230P30	F3SG-4RE1230N30
64	1,310	F3SG-4RE1310P30	F3SG-4RE1310N30
68	1,390	F3SG-4RE1390P30	F3SG-4RE1390N30
72	1,470	F3SG-4RE1470P30	F3SG-4RE1470N30
76	1,550	F3SG-4RE1550P30	F3SG-4RE1550N30
80	1,630	F3SG-4RE1630P30	F3SG-4RE1630N30
84	1,710	F3SG-4RE1710P30	F3SG-4RE1710N30
88	1,790	F3SG-4RE1790P30	F3SG-4RE1790N30
92	1,870	F3SG-4RE1870P30	F3SG-4RE1870N30
96	1,950	F3SG-4RE1950P30	F3SG-4RE1950N30
100	2,030	F3SG-4RE2030P30	F3SG-4RE2030N30
104	2,110	F3SG-4RE2110P30	F3SG-4RE2110N30
108	2,190	F3SG-4RE2190P30	F3SG-4RE2190N30
112	2,270	F3SG-4RE2270P30	F3SG-4RE2270N30
116	2,350	F3SG-4RE2350P30	F3SG-4RE2350N30
120	2,430	F3SG-4RE2430P30	F3SG-4RE2430N30
124	2,510	F3SG-4RE2510P30	F3SG-4RE2510N30

## Accessories (Sold separately)

### Safety light curtain connecting cable

#### Single-Ended Cable (Round Water-resistant Connector: Connector Connected to Cable, Socket on One Cable End)

Appearance	Type	Cable length	Specifications	Model																				
	M12 connector (4-pin), 4 wires	1 m	 <table border="1"> <thead> <tr> <th>PIN</th> <th>Emitter</th> <th>Receiver</th> <th>Color</th> </tr> </thead> <tbody> <tr> <td>1</td> <td>+24 VDC</td> <td>+24 VDC</td> <td>Brown</td> </tr> <tr> <td>2</td> <td>Range setting</td> <td>OSSD 2</td> <td>White</td> </tr> <tr> <td>3</td> <td>0 VDC</td> <td>0 VDC</td> <td>Blue</td> </tr> <tr> <td>4</td> <td>Not used</td> <td>OSSD 1</td> <td>Black</td> </tr> </tbody> </table>	PIN	Emitter	Receiver	Color	1	+24 VDC	+24 VDC	Brown	2	Range setting	OSSD 2	White	3	0 VDC	0 VDC	Blue	4	Not used	OSSD 1	Black	XS5F-D421-C80-F
		PIN		Emitter	Receiver	Color																		
		1		+24 VDC	+24 VDC	Brown																		
		2		Range setting	OSSD 2	White																		
		3		0 VDC	0 VDC	Blue																		
		4		Not used	OSSD 1	Black																		
2 m	XS5F-D421-D80-F																							
3 m	XS5F-D421-E80-F																							
5 m	XS5F-D421-G80-F																							
10 m	XS5F-D421-J80-F																							
20 m	XS5F-D421-L80-F																							

- Note:** 1. One cable that can be used for both emitter and receiver is provided. Order two cables for one set of safety light curtains.  
 2. To extend the cable length to 20 m or more, add the XS5W-D421-□81-F Double-Ended Cable.

#### Double-Ended Cable (Round Water-resistant Connector: Connectors Connected to Cable, Socket and Plug on Cable Ends) For cable extension and simple wiring

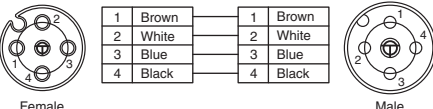
Appearance	Type	Cable length	Specifications	Model																
	M12 connector (4-pin) on both ends	1 m	 <table border="1"> <thead> <tr> <th>1</th> <th>Brown</th> <th>1</th> <th>Brown</th> </tr> </thead> <tbody> <tr> <td>2</td> <td>White</td> <td>2</td> <td>White</td> </tr> <tr> <td>3</td> <td>Blue</td> <td>3</td> <td>Blue</td> </tr> <tr> <td>4</td> <td>Black</td> <td>4</td> <td>Black</td> </tr> </tbody> </table>	1	Brown	1	Brown	2	White	2	White	3	Blue	3	Blue	4	Black	4	Black	XS5W-D421-C81-F
		1		Brown	1	Brown														
		2		White	2	White														
		3		Blue	3	Blue														
		4		Black	4	Black														
		2 m		XS5W-D421-D81-F																
3 m	XS5W-D421-E81-F																			
5 m	XS5W-D421-G81-F																			
10 m	XS5W-D421-J81-F																			
20 m	XS5W-D421-L81-F																			

- Note:** 1. One cable that can be used for both emitter and receiver is provided. Order two cables for one set of safety light curtains.  
 2. To extend the cable length to more than 20 m, add the XS5W-D421-□81-F Double-Ended Cable to the XS5F-D421-□80-F Single-Ended Cable.  
 To extend the cable length to more than 40 m, add several Double-Ended Cables to the Single-Ended Cable.  
 Example: To extend the cable length to 50 m, connect two XS5W-D421-L81-F (20 m) cables and one XS5F-D421-J80-F (10 m) cable.

#### <Connection example>

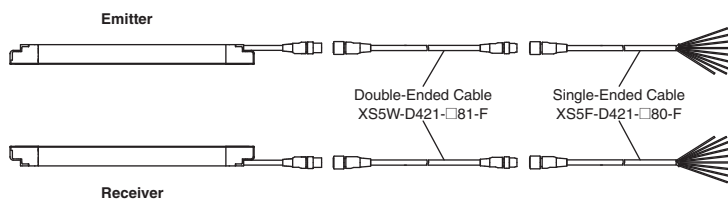



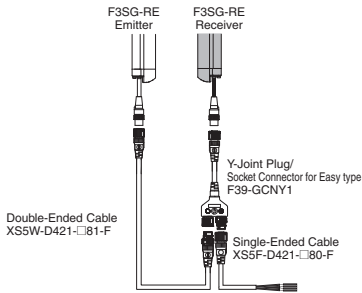

#### Y-Joint Plug/Socket Connector for Easy type F3SG-RE

Appearance	Type	Cable length	Specifications	Model
	M12 connectors. Used for reduced wiring.	0.5 m	 <p>When using the reduced wiring connector system F39-GCNY1, the Operating Range Selection is fixed to Long Mode.</p>	F39-GCNY1

# F3SG-RE

## Sensor Mounting Brackets

Appearance	Specification	Application	Model
	Standard Fixed Bracket	Bracket to mount the F3SG-R. Side mounting and backside mounting possible. (This is included as a standard accessory with the product. It comes as a set of two Brackets. Refer to note *1 for the number of sets provided with each model.)	<b>F39-LGF</b>
	Standard Adjustable Bracket	Bracket to mount the F3SG-R. Beam alignment after mounting possible. The angle adjustment range is $\pm 15^\circ$ . Side mounting and backside mounting possible. (Sold separately as a set of two Brackets. Refer to note *1 for the number of sets required for each model.)	<b>F39-LGA</b>
	Top/Bottom Adjustable Bracket *2	Bracket to mount the F3SG-R. Use this bracket at the top and bottom positions of the F3SG-R. Beam alignment after mounting possible. The angle adjustment range is $\pm 22.5^\circ$ . Side mounting and backside mounting possible. (Sold separately. 4 brackets per set.)	<b>F39-LGTB</b>
	Top/Bottom Adjustable Bracket *2 (For user-made mounting part)	Top/Bottom Adjustable Bracket without a bracket to mount to the wall. Use the user's own wall mounting part to suit the machine. (Sold separately. 4 brackets per set.)	<b>F39-LGTB-1</b>

\*1. [for F3SG-4RE□□□□□14] Protective height of 0160 to 1200: 2 sets, Protective height of 1280 to 2080: 3 sets [for F3SG-4RE□□□□□30] Protective height of 0190 to 1230: 2 sets, Protective height of 1310 to 2270: 3 sets, Protective height of 2350 to 2510: 4 sets

\*2. Top/Bottom Adjustable Bracket cannot be used with the Standard Fixed Bracket. Use with the Standard Adjustable Bracket.

Using Top/Bottom Adjustable Brackets with Standard Adjustable Brackets

F3SG-4RE□□□□□14: Protective height of 1040 or less: The Standard Adjustable Bracket is not required. Please purchase 1 set of Top/Bottom Adjustable Brackets (F39-LGTB(-1)).

Protective height of 1120 to 1920: Please purchase 1 set of Top/Bottom Adjustable Brackets (F39-LGTB(-1)) and 1 set of Standard Adjustable Brackets (F39-LGA).

Protective height of 2000 to 2080: Please purchase 1 set of Top/Bottom Adjustable Brackets (F39-LGTB(-1)) and 2 sets of Standard Adjustable Brackets (F39-LGA).

F3SG-4RE□□□□□30: Protective height of 1070 or less: The Standard Adjustable Bracket is not required. Please purchase 1 set of Top/Bottom Adjustable Brackets (F39-LGTB(-1)).

Protective height of 1150 to 1950: Please purchase 1 set of Top/Bottom Adjustable Brackets (F39-LGTB(-1)) and 1 set of Standard Adjustable Brackets (F39-LGA).

Protective height of 2030 to 2510: Please purchase 1 set of Top/Bottom Adjustable Brackets (F39-LGTB(-1)) and 2 sets of Standard Adjustable Brackets (F39-LGA).

## Laser Pointer for F3SG-R

Appearance	Specifications	Model
	The laser pointer is attached on the optical surface of the F3SG-R to help coarse adjustment of beams.	<b>F39-PTG</b>

## Spatter Protection Cover (2 covers per set, one for emitter and one for receiver)

Spatter Protection Covers include the mounting brackets.

For Safety Light Curtain models of the protective height of 2,000 mm or longer, use two Spatter Protection Covers of different lengths.

Appearance	Safety Light Curtain Model		Model	
	Finger protection	Hand and arm protection		
	F3SG-4RE0160□14	F3SG-4RE0190□30	F39-HGB0180	
	F3SG-4RE0240□14	F3SG-4RE0270□30	F39-HGB0260	
	F3SG-4RE0320□14	F3SG-4RE0350□30	F39-HGB0340	
	F3SG-4RE0400□14	F3SG-4RE0430□30	F39-HGB0420	
	F3SG-4RE0480□14	F3SG-4RE0510□30	F39-HGB0500	
	F3SG-4RE0560□14	F3SG-4RE0590□30	F39-HGB0580	
	F3SG-4RE0640□14	F3SG-4RE0670□30	F39-HGB0660	
	F3SG-4RE0720□14	F3SG-4RE0750□30	F39-HGB0740	
	F3SG-4RE0800□14	F3SG-4RE0830□30	F39-HGB0820	
	F3SG-4RE0880□14	F3SG-4RE0910□30	F39-HGB0900	
	F3SG-4RE0960□14	F3SG-4RE0990□30	F39-HGB0980	
	F3SG-4RE1040□14	F3SG-4RE1070□30	F39-HGB1060	
	F3SG-4RE1120□14	F3SG-4RE1150□30	F39-HGB1140	
	F3SG-4RE1200□14	F3SG-4RE1230□30	F39-HGB1220	
	F3SG-4RE1280□14	F3SG-4RE1310□30	F39-HGB1300	
	F3SG-4RE1360□14	F3SG-4RE1390□30	F39-HGB1380	
	F3SG-4RE1440□14	F3SG-4RE1470□30	F39-HGB1460	
	F3SG-4RE1520□14	F3SG-4RE1550□30	F39-HGB1540	
	F3SG-4RE1600□14	F3SG-4RE1630□30	F39-HGB1620	
	F3SG-4RE1680□14	F3SG-4RE1710□30	F39-HGB1700	
	F3SG-4RE1760□14	F3SG-4RE1790□30	F39-HGB1780	
	F3SG-4RE1840□14	F3SG-4RE1870□30	F39-HGB1860	
	F3SG-4RE1920□14	F3SG-4RE1950□30	F39-HGB1940	
		F3SG-4RE2000□14	F3SG-4RE2030□30	F39-HGB1460
				F39-HGA0550
		F3SG-4RE2080□14	F3SG-4RE2110□30	F39-HGB1540
				F39-HGA0550
		-	F3SG-4RE2190□30	F39-HGB1620
				F39-HGA0550
		-	F3SG-4RE2270□30	F39-HGB1700
			F39-HGA0550	
	-	F3SG-4RE2350□30	F39-HGB1780	
			F39-HGA0550	
	-	F3SG-4RE2430□30	F39-HGB1860	
			F39-HGA0550	
	-	F3SG-4RE2510□30	F39-HGB1940	
			F39-HGA0550	

Note: The operating range of the Safety Light Curtain attached with the product is 10% shorter than the rating.

### Test Rod

Diameter	Model
14 mm dia.	F39-TRD14
30 mm dia.	F39-TRD30

## Ratings/Specifications

### Main unit

The □□□□ in the model names indicate the protective heights in millimeters.

		F3SG-4RE□□□□-14, F3SG-2RE□□□□-14	F3SG-4RE□□□□-30, F3SG-2RE□□□□-30	
Performance	Type of ESPE (IEC 61496-1)	Type 4 F3SG-4RE□□□□□□14/30	Type 2 F3SG-2RE□□□□□□14/30	
	Object Resolution (Detection Capability)	Opaque objects		
	Beam Gap	14-mm dia.	30-mm dia.	
	Number of Beams	10mm	20mm	
	Lens Size	15 to 207	8 to 124	
	Protective Height	5.2 x 3.4 (WxH) mm	7-mm dia.	
	Operating Range	Long	160 to 2080 mm (6.3 to 81.9 inch)	190 to 2510 mm (7.3 to 98.7 inch)
		Short	0.3 to 10.0 m (1 to 32 ft.)	0.3 to 20.0 m (1 to 65 ft.)
	Response Time	ON to OFF	0.3 to 3.0 m (1 to 10 ft.)	0.3 to 7.0 m (1 to 23 ft.)
		OFF to ON	5 to 15ms *1	25 to 75ms *1
Effective Aperture Angle (EAA) (IEC61496-2)	Type 4	±2.5° max., emitter and receiver at operating range of 3 m or greater		
	Type 2	±5.0° max., emitter and receiver at operating range of 3 m or greater		

\*1.Response time when used in one segment system  
 Refer to page 79.

# F3SG-RE

		F3SG-4RE□□□□-14, F3SG-2RE□□□□-14	F3SG-4RE□□□□-30, F3SG-2RE□□□□-30
Performance	Light Source	Infrared LEDs, Wavelength: 870 nm	
	Startup Waiting Time	2 s max.	
Electrical	Power Supply Voltage (Vs)	SELV/PELV 24 VDC±20% (ripple p-p 10% max.)	
	Current Consumption	Refer to page 79	
	Safety Outputs (OSSD)	F3SG-□RE□□□□P□□: Two PNP transistor outputs F3SG-□RE□□□□N□□: Two NPN transistor outputs	
		Load current of 300 mA max., Residual voltage of 2 V max. (except for voltage drop due to cable extension), Capacitive load of 1 μF max., Inductive load of 2.2 H max. *1 Leakage current of 1 mA max. (PNP), 2 mA max. (NPN) *2 *1. The load inductance is the maximum value when the safety output frequently repeats ON and OFF. When you use the safety output at 4 Hz or less, the usable load inductance becomes larger. *2. These values must be taken into consideration when connecting elements including a capacitive load such as a capacitor.	
	Output Operation Mode	Safety Output	Light-ON (Safety output is enabled when the receiver receives an emitting signal.)
	Input Voltage	Operating Range Select Input: Long: 9 V to Vs (short circuit current: approx. 2.5 mA) * Short: 0 to 3 V (short circuit current: approx. 2.0 mA) The F3SG-RE enters the Long Mode when the Operating Range Select Input line is open.	
		* The Vs indicates a supply voltage value in your environment.	
	Overvoltage Category (IEC60664-1)	II	
	Indicators	Refer to page 80	
	Protective Circuit	Output short protection, Power supply reverse polarity protection	
Insulation Resistance	20 MΩ or higher (500 VDC megger)		
Dielectric Strength	1,000 VAC, 50/60 Hz (1 min)		
Functional	Test Function	Self-test (at power-on, and during operation)	
Environmental	Ambient Temperature	Operating	-10 to 55°C (14 to 131°F) (non-icing)
		Storage	-25 to 70°C (-13 to 158°F)
	Ambient Humidity	Operating	35% to 85% (non-condensing)
		Storage	35% to 95%
	Ambient Illuminance	Incandescent lamp: 3,000 lx max. on receiver surface Sunlight: 10,000 lx max. on receiver surface	
	Degree of Protection (IEC 60529)	IP65 and IP67	
	Vibration Resistance (IEC 61496-1)	Class 3M4 (IEC TR 60721-4-3) Operation limit: 5 to 150 Hz, Multiple amplitude of 7 mm, Acceleration of 1 G, 10 sweeps each in X, Y, and Z directions (no delay at resonant frequencies)	
	Shock Resistance (IEC 61496-1)	Class 3M4 (IEC TR 60721-4-3) Operation limit: Acceleration of 15 G, Pulse duration of 6 ms, 100 shocks for each in X, Y, and Z directions (600 shocks in total)	
Pollution Degree (IEC 60664-1)	Pollution Degree 3		
Connections	Power cable	Type of Connection	M12 connectors: 4-pin, IP67 rated when mated, Cables prewired to the sensors
		Number of Wires	Emitter: 4, Receiver: 4
		Cable Length	0.3 m
		Cable Diameter	6 mm
		Minimum Bending Radius	R5 mm
	Extension cable - Single-Ended Cable - Double-Ended Cable	Type of Connection	Use the XS5□-D42□ series cables.
		Number of Wires	
Cable Length			
Extension of Power Cable	Cable Diameter		
	Minimum Bending Radius		
Material	Material	Housing: Aluminum alloy Cap: PBT resin Front window: Acrylic resin Cable: Oil-resistant PVC resin Standard Fixed Bracket (F39-LGF): Zinc alloy FE plate: Stainless steel	
	Weight	Refer to page 79.	
	Included Accessories	Safety Precautions, Quick Installation Manual, Standard Fixed Bracket*1, Troubleshooting Guide Sticker	
		*1. The quantity of Standard Fixed Brackets included varies depending on the protective height. [F3SG-□RE□□□□14] - Protective height of 0160 to 1200: 2 sets - Protective height of 1280 to 2080: 3 sets [F3SG-□RE□□□□30] - Protective height of 0190 to 1230: 2 sets - Protective height of 1310 to 2270: 3 sets - Protective height of 2350 to 2510: 4 sets	
Conformity	Conforming standards	Refer to page 26	
	Performance Level (PL)/Safety category	Type 4	PL e/Category 4 (EN ISO 13849-1:2015)
		Type 2	PL c/Category 2 (EN ISO 13849-1:2015)
	PFH <sub>D</sub>	9.1 × 10 <sup>-9</sup> (IEC 61508)	
	Proof test interval T <sub>M</sub>	Every 20 years (IEC 61508)	
	SFF	99% (IEC 61508)	
	HFT	1 (IEC 61508)	
Classification	Type B (IEC 61508-2)		

## List of Models/Response Time/Current Consumption/Weight

## F3SG-□RE□□□□□14

Model	Number of Beams	Protective Height [mm]	Response Time [ms] *1			Current Consumption [mA]		Weight [kg]	
			ON→OFF	OFF (Synchronized) →ON	OFF (Not synchronized) →ON	Emitter	Receiver	Net *2	Gross *3
F3SG-□RE0160□14	15	160	5	25	125	45	50	0.6	1.9
F3SG-□RE0240□14	23	240	5	25	125	55	55	0.8	2.2
F3SG-□RE0320□14	31	320	7	35	135	55	55	1.0	2.5
F3SG-□RE0400□14	39	400	7	35	135	65	60	1.2	2.9
F3SG-□RE0480□14	47	480	7	35	135	70	60	1.4	3.2
F3SG-□RE0560□14	55	560	7	35	135	80	60	1.6	3.5
F3SG-□RE0640□14	63	640	7	35	135	85	65	1.9	3.8
F3SG-□RE0720□14	71	720	9	45	145	80	65	2.1	4.1
F3SG-□RE0800□14	79	800	9	45	145	85	70	2.3	4.4
F3SG-□RE0880□14	87	880	9	45	145	90	70	2.5	4.7
F3SG-□RE0960□14	95	960	9	45	145	95	75	2.7	5.0
F3SG-□RE1040□14	103	1040	9	45	145	100	75	2.9	5.4
F3SG-□RE1120□14	111	1120	11	55	155	90	75	3.1	5.7
F3SG-□RE1200□14	119	1200	11	55	155	95	80	3.3	6.0
F3SG-□RE1280□14	127	1280	11	55	155	100	80	3.5	6.3
F3SG-□RE1360□14	135	1360	11	55	155	105	85	3.7	6.6
F3SG-□RE1440□14	143	1440	11	55	155	110	85	3.9	6.9
F3SG-□RE1520□14	151	1520	13	65	165	100	90	4.1	7.2
F3SG-□RE1600□14	159	1600	13	65	165	105	90	4.4	7.5
F3SG-□RE1680□14	167	1680	13	65	165	110	95	4.6	7.9
F3SG-□RE1760□14	175	1760	13	65	165	115	95	4.8	8.2
F3SG-□RE1840□14	183	1840	13	65	165	115	95	5.0	8.5
F3SG-□RE1920□14	191	1920	15	75	175	110	100	5.2	8.8
F3SG-□RE2000□14	199	2000	15	75	175	115	100	5.4	9.1
F3SG-□RE2080□14	207	2080	15	75	175	115	105	5.6	9.4

\*1. The maximum speed of movement of a test rod up to which the detection capability is maintained is 2.0 m/s.

\*2. The net weight is the weight of an emitter and a receiver.

\*3. The gross weight is the weight of an emitter, a receiver, included accessories and a package.

## F3SG-□RE□□□□□30

Model	Number of Beams	Protective Height [mm]	Response Time [ms] *1			Current Consumption [mA]		Weight [kg]	
			ON→OFF	OFF (Synchronized) →ON	OFF (Not synchronized) →ON	Emitter	Receiver	Net *2	Gross *3
F3SG-□RE0190□30	8	190	5	25	125	40	50	0.6	2.0
F3SG-□RE0270□30	12	270	5	25	125	45	50	0.8	2.3
F3SG-□RE0350□30	16	350	5	25	125	50	50	1.0	2.6
F3SG-□RE0430□30	20	430	5	25	125	55	55	1.2	2.9
F3SG-□RE0510□30	24	510	5	25	125	60	55	1.4	3.2
F3SG-□RE0590□30	28	590	7	35	135	50	55	1.6	3.5
F3SG-□RE0670□30	32	670	7	35	135	55	55	1.8	3.8
F3SG-□RE0750□30	36	750	7	35	135	60	60	2.0	4.1
F3SG-□RE0830□30	40	830	7	35	135	65	60	2.2	4.4
F3SG-□RE0910□30	44	910	7	35	135	65	60	2.4	4.7
F3SG-□RE0990□30	48	990	7	35	135	70	60	2.6	5.0
F3SG-□RE1070□30	52	1070	7	35	135	75	60	2.8	5.3
F3SG-□RE1150□30	56	1150	7	35	135	80	65	3.0	5.6
F3SG-□RE1230□30	60	1230	7	35	135	85	65	3.3	5.9
F3SG-□RE1310□30	64	1310	7	35	135	85	65	3.5	6.2
F3SG-□RE1390□30	68	1390	9	45	145	75	65	3.7	6.5
F3SG-□RE1470□30	72	1470	9	45	145	80	65	3.9	6.8
F3SG-□RE1550□30	76	1550	9	45	145	80	70	4.1	7.1
F3SG-□RE1630□30	80	1630	9	45	145	85	70	4.3	7.4
F3SG-□RE1710□30	84	1710	9	45	145	85	70	4.5	7.7
F3SG-□RE1790□30	88	1790	9	45	145	90	70	4.7	8.0
F3SG-□RE1870□30	92	1870	9	45	145	95	75	4.9	8.3
F3SG-□RE1950□30	96	1950	9	45	145	95	75	5.1	8.6
F3SG-□RE2030□30	100	2030	9	45	145	100	75	5.3	8.9
F3SG-□RE2110□30	104	2110	9	45	145	100	75	5.5	9.2
F3SG-□RE2190□30	108	2190	11	55	155	90	75	5.7	9.5
F3SG-□RE2270□30	112	2270	11	55	155	95	80	5.9	9.8
F3SG-□RE2350□30	116	2350	11	55	155	95	80	6.1	10.1
F3SG-□RE2430□30	120	2430	11	55	155	95	80	6.3	10.4
F3SG-□RE2510□30	124	2510	11	55	155	100	80	6.5	10.7

\*1. The maximum speed of movement of a test rod up to which the detection capability is maintained is 2.0 m/s.

\*2. The net weight is the weight of an emitter and a receiver.

\*3. The gross weight is the weight of an emitter, a receiver, included accessories and a package.

## Legislation and Standards

For F3SG-RE laws, regulations, and standards, refer to F3SG-RA datasheet *Legislation and Standards* on page 26.

## LED Indicator Status

### Emitter

Name of Indicator		Color	Illuminated	Blinking
Operating range	LONG	Green	Long range mode is selected	Lockout state due to Operating range selection setting error
Power	POWER	Green	Power is ON.	Error due to noise
Lockout	LOCKOUT	Red	–	Lockout state due to error in emitter

### Receiver

Name of Indicator		Color	Illuminated	Blinking
Top-beam-state	TOP	Blue	The top beam is unblocked	–
Internal error	INTERNAL	Red	–	Lockout state due to Internal error, or error due to abnormal power supply or noise
Lockout	LOCKOUT	Red	–	Lockout state due to error in receiver
Stable-state	STB	Green	Incident light level is 170% or higher of ON threshold	Safety output is instantaneously turned OFF due to ambient light or vibration
ON/OFF	ON/OFF	Green	Safety output is in ON state	–
		Red	Safety output is in OFF state	Lockout state due to Safety Output error, or error due to abnormal power supply or noise
Communication	COM	Green	Synchronization between emitter and receiver is maintained	Lockout state due to Communication error, or error due to abnormal power supply or noise
Bottom-beam-state	BTM	Blue	The bottom beam is unblocked	–

# Connections (Basic Wiring Diagram)

## Short Mode

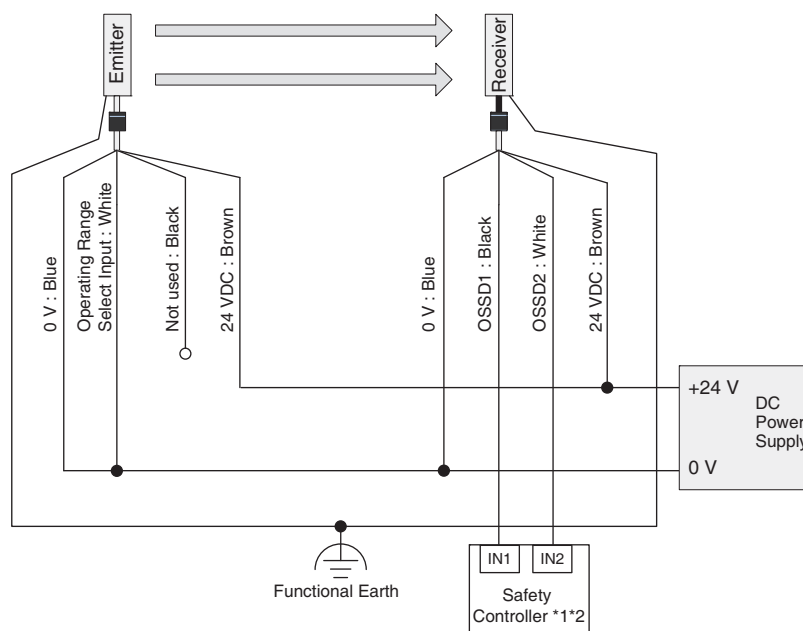

\*1.Refer to page 82 for more information.

\*2.The safety controller and the F3SG-RE must share the power supply or be connected to the common terminal of the power supply.

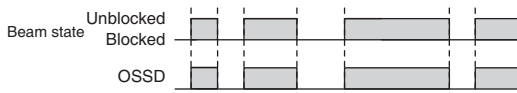

**Note:** Functional earth connection is unnecessary when you use the F3SG-RE in a general industrial environment where noise control or stable power supply is considered. However, when you use the F3SG-RE in an environment where there may be excessive noise from surroundings or stable power supply may be interfered, it is recommended the F3SG-RE be connected to functional earth. The wiring examples in later examples do not indicate functional earth. To use functional earth, wire an earth cable according to the example above. Refer to *Safety Light Curtain F3SG-R Series User's Manual* for more information.

## Long Mode

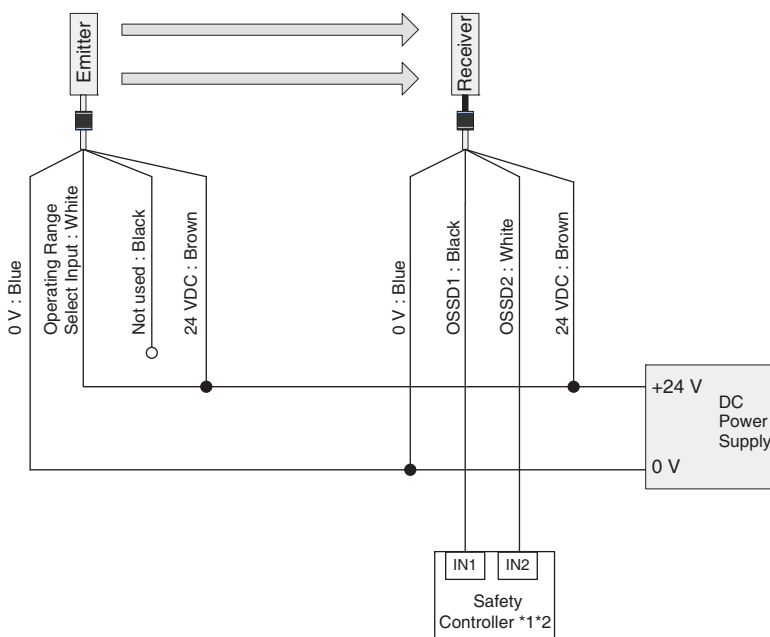

\*1.Refer to page 82 for more information.

\*2.The safety controller and the F3SG-RE must share the power supply or be connected to the common terminal of the power supply.

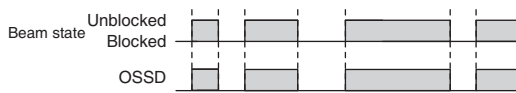

**Note:** For the functional earth connection, refer to the Short Mode example.

## Standalone F3SG-RE with Y-Joint Plug/Socket Connector

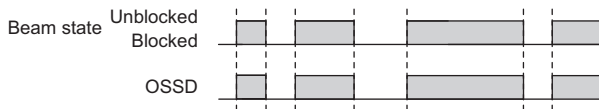
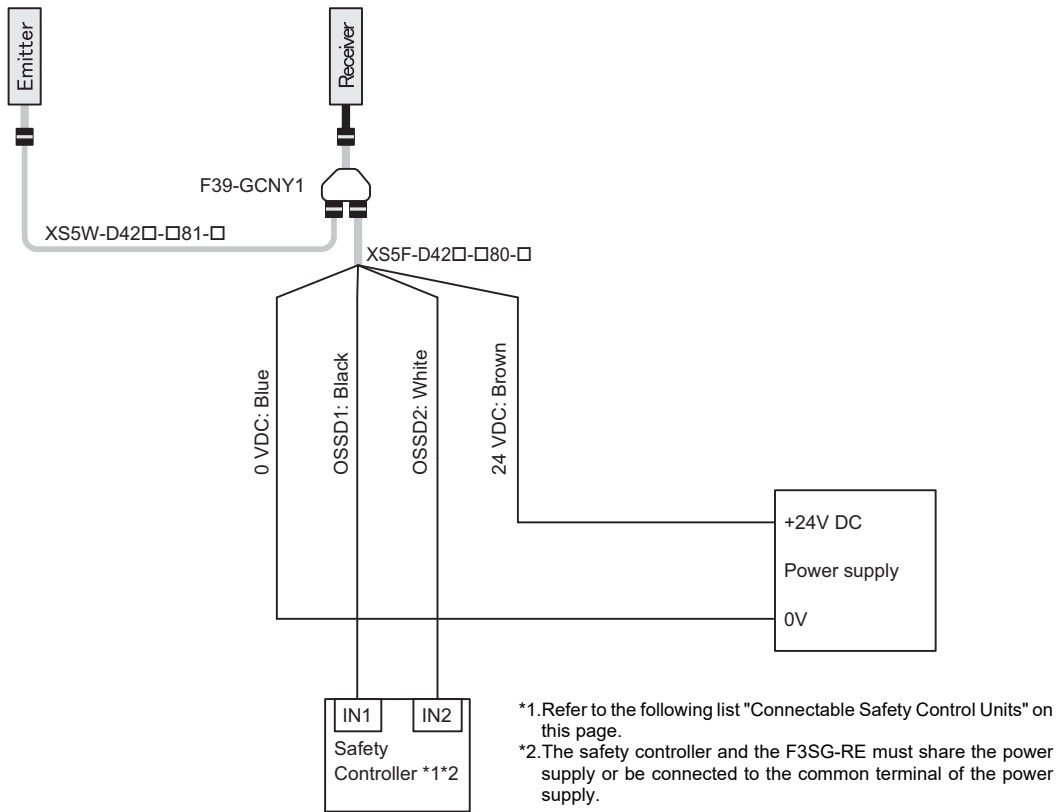

- Note:** 1. When using the reduced wiring connector system F39-GCNY1, the Operating Range Selection is fixed to Long Mode.  
 2. For the functional earth connection, refer to the Short Mode example.

## Connectable Safety Control Units

The F3SG-RE with PNP output can be connected to the safety control units listed in the table below.

Connectable Safety Control Units (PNP output)		
Safety Relay Units	Flexible Safety Units	Safety Controllers
G9SA-301 G9SA-321-T□ G9SA-501 G9SB-200-B G9SB-200-D G9SB-301-B G9SB-301-D G9SE-201 G9SE-401 G9SE-221-T□	G9SX-AD322-T G9SX-ADA222-T G9SX-BC202 G9SX-GS226-T15	G9SP-N10S G9SP-N10D G9SP-N20S NE0A-SCPU01 NE1A-SCPU01 NE1A-SCPU02 DST1-ID12SL-1 DST1-MD16SL-1 DST1-MRD08SL-1 NX-SIH400 NX-SID800 F3SP-T01

The F3SG-R with NPN output can be connected to the safety control units listed in the table below.

Connectable Safety Control Units (NPN output)
Safety Relay Units
G9SA-301-P

# Input/Output Circuit

## Entire Circuit Diagram

The entire circuit diagram of the F3SG-RE is shown below. The numbers in the circles indicate the connector's pin numbers.

### PNP Output

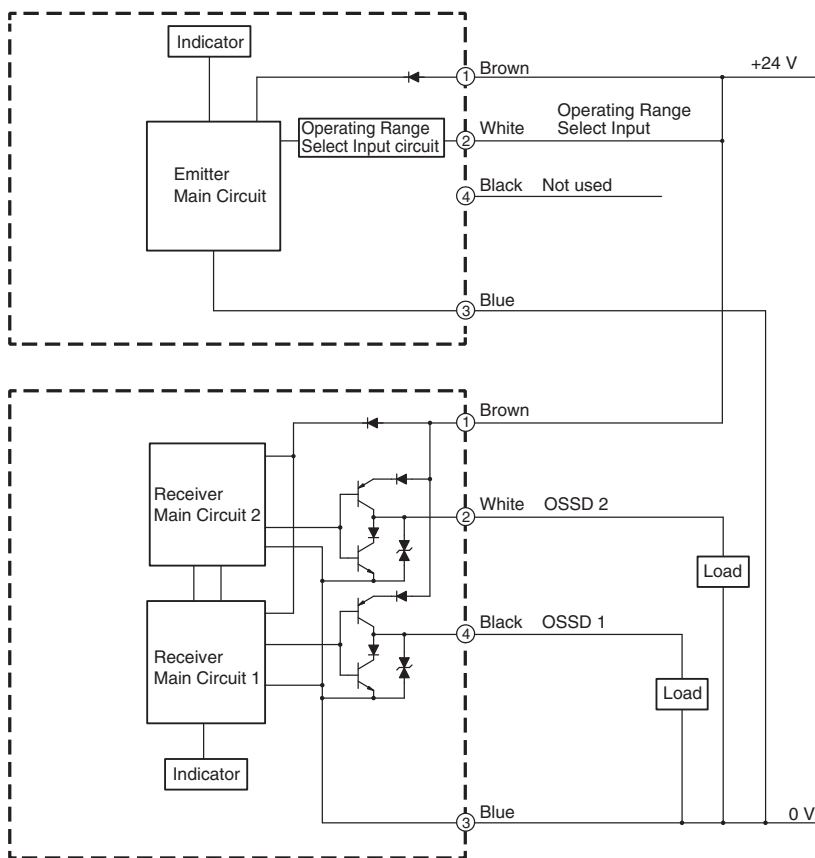

### NPN Output

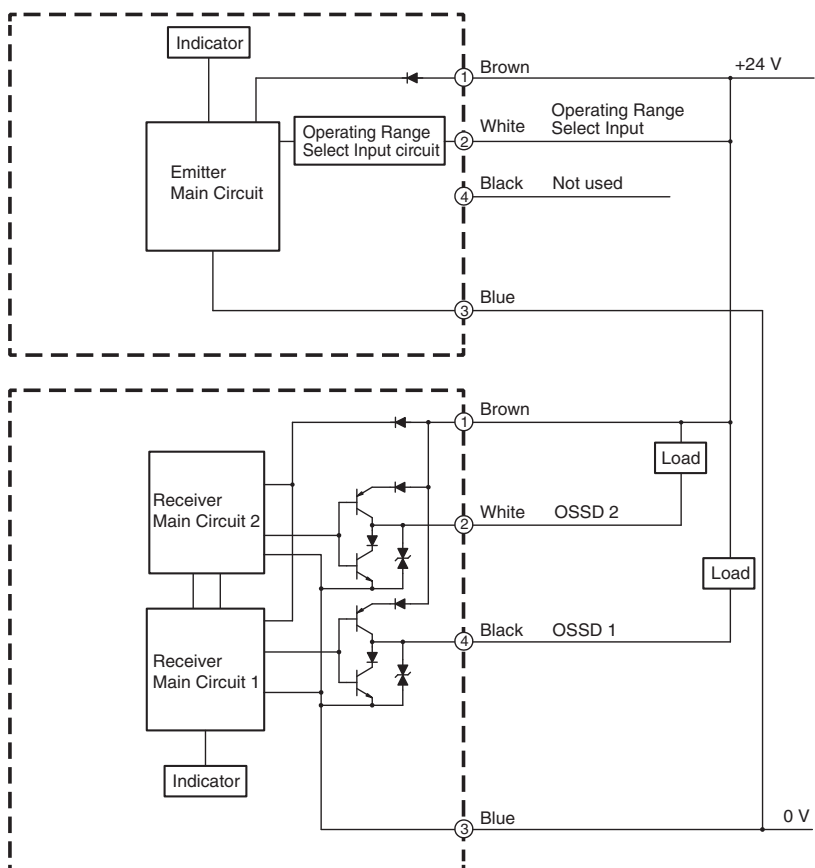

F3SG-RE

## Input Circuit Diagram by Function

The input circuit diagrams of by function are shown below.

### Operating Range Select Input

<Long Mode>

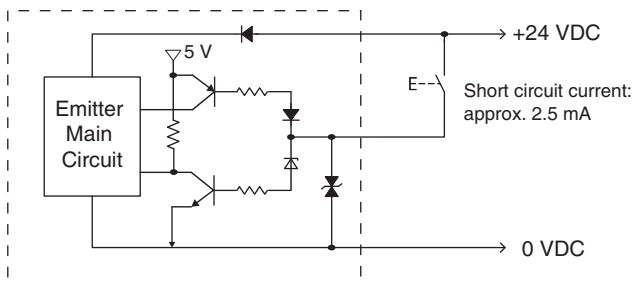

<Short Mode>

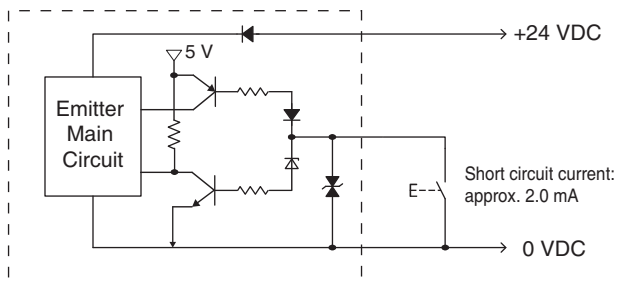

# Dimensions

## Mounted with Standard Fixed Brackets (F39-LGF) Backside Mounting

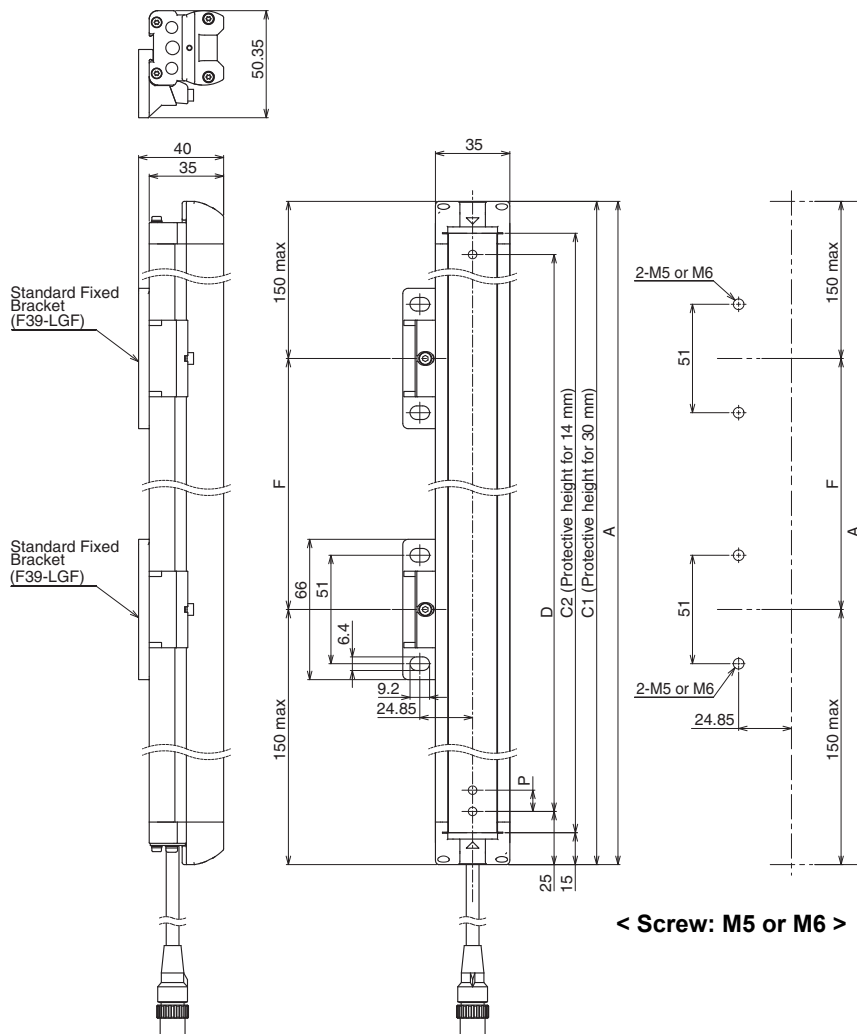

### F3SG-4RE□□□□30 Series

Dimension A	C1
Dimension C1	4-digit number of the type name(Protective height)
Dimension D	C1-50
Dimension P	20

Protective height (C1)	Number of Standard Fixed Brackets *1	Dimension F
0190 to 1230	2 *2	1000 mm max.
1310 to 2270	3	1000 mm max.
2350 to 2510	4	1000 mm max.

### F3SG-4RE□□□□14 Series

Dimension A	C2+30
Dimension C2	4-digit number of the type name(Protective height)
Dimension D	C2-20
Dimension P	10

Protective height (C2)	Number of Standard Fixed Brackets *1	Dimension F
0160 to 1200	2 *2	1000 mm max.
1280 to 2080	3	1000 mm max.

\*1.The number of brackets required to mount either one of emitter and receiver.

\*2.Mounting an emitter or receiver with one bracket is possible for the models of protective height of 0160 to 0270. In this case, locate this bracket at half the Dimension A (or at the center of the sensor length).

F3SG-RE

## Side Mounting

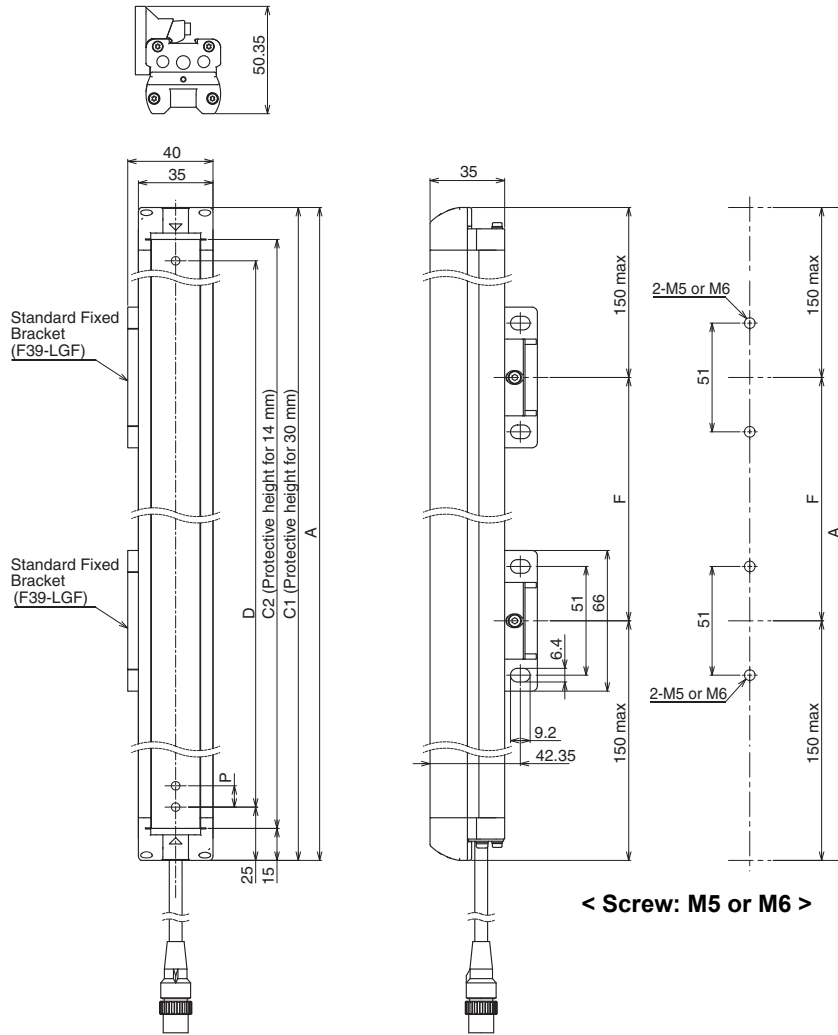

### F3SG-4RE□□□□30 Series

Dimension A	C1
Dimension C1	4-digit number of the type name (Protective height)
Dimension D	C1-50
Dimension P	20

Protective height (C1)	Number of Standard Fixed Brackets *1	Dimension F
0190 to 1230	2 *2	1000 mm max.
1310 to 2270	3	1000 mm max.
2350 to 2510	4	1000 mm max.

### F3SG-4RE□□□□14 Series

Dimension A	C2+30
Dimension C2	4-digit number of the type name (Protective height)
Dimension D	C2-20
Dimension P	10

Protective height (C2)	Number of Standard Fixed Brackets *1	Dimension F
0160 to 1200	2 *2	1000 mm max.
1280 to 2080	3	1000 mm max.

\*1. The number of brackets required to mount either one of emitter and receiver.

\*2. Mounting an emitter or receiver with one bracket is possible for the models of protective height of 0160 to 0270. In this case, locate this bracket at half the Dimension A (or at the center of the sensor length).

**Mounted with Standard Fixed Brackets (F39-LGA)  
Backside Mounting**

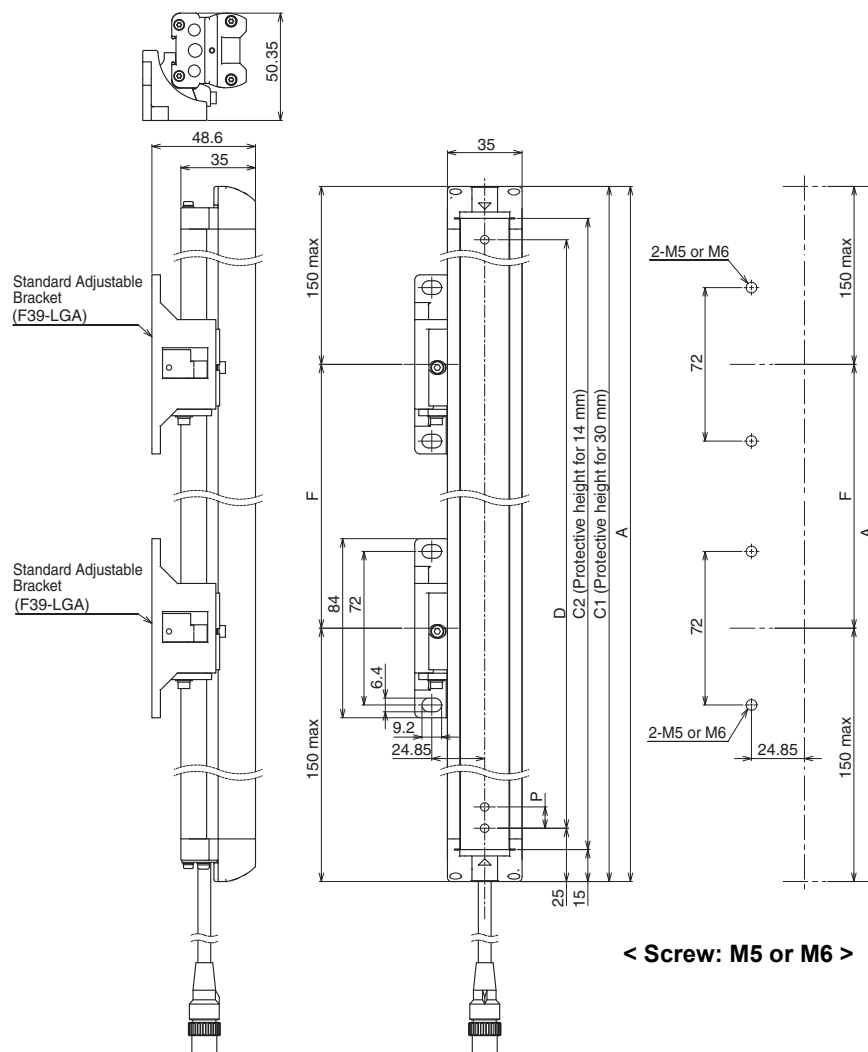

**F3SG-4RE□□□□□30 Series**

<b>Dimension A</b>	C1
<b>Dimension C1</b>	4-digit number of the type name (Protective height)
<b>Dimension D</b>	C1-50
<b>Dimension P</b>	20

Protective height (C1)	Number of Standard Adjustable Brackets *1	Dimension F
0190 to 1230	2 *2	1000 mm max.
1310 to 2270	3	1000 mm max.
2350 to 2510	4	1000 mm max.

**F3SG-4RE□□□□□14 Series**

<b>Dimension A</b>	C2+30
<b>Dimension C2</b>	4-digit number of the type name (Protective height)
<b>Dimension D</b>	C2-20
<b>Dimension P</b>	10

Protective height (C2)	Number of Standard Adjustable Brackets *1	Dimension F
0160 to 1200	2 *2	1000 mm max.
1280 to 2080	3	1000 mm max.

\*1. The number of brackets required to mount either one of emitter and receiver.

\*2. Mounting an emitter or receiver with one bracket is possible for the models of protective height of 0160 to 0270. In this case, locate this bracket at half the Dimension A (or at the center of the sensor length).

F3SG-RE

## Side Mounting

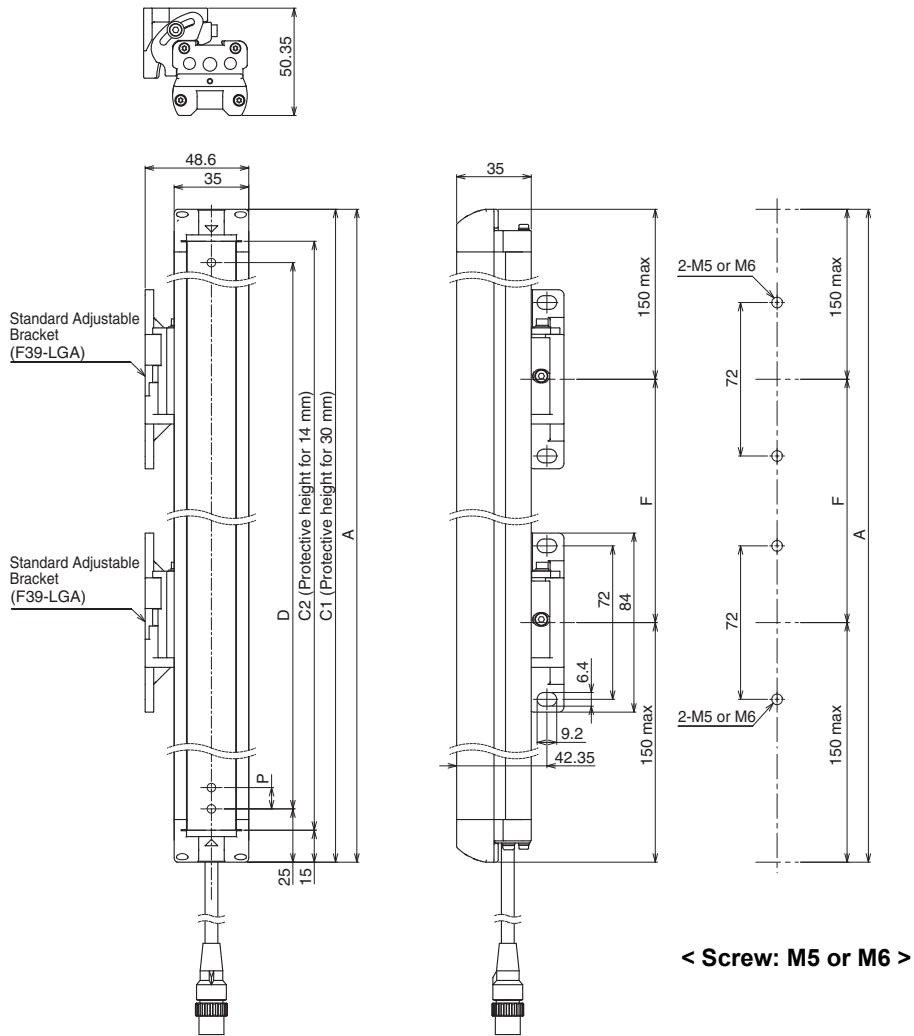

### F3SG-4RE□□□□30 Series

<b>Dimension A</b>	C1
<b>Dimension C1</b>	4-digit number of the type name (Protective height)
<b>Dimension D</b>	C1-50
<b>Dimension P</b>	20

Protective height (C1)	Number of Standard Adjustable Brackets *1	Dimension F
0190 to 1230	2 *2	1000 mm max.
1310 to 2270	3	1000 mm max.
2350 to 2510	4	1000 mm max.

### F3SG-4RE□□□□14 Series

<b>Dimension A</b>	C2+30
<b>Dimension C2</b>	4-digit number of the type name (Protective height)
<b>Dimension D</b>	C2-20
<b>Dimension P</b>	10

Protective height (C2)	Number of Standard Adjustable Brackets *1	Dimension F
0160 to 1200	2 *2	1000 mm max.
1280 to 2080	3	1000 mm max.

\*1. The number of brackets required to mount either one of emitter and receiver.

\*2. Mounting an emitter or receiver with one bracket is possible for the models of protective height of 0160 to 0270. In this case, locate this bracket at half the Dimension A (or at the center of the sensor length).

## Mounted with Top/Bottom Adjustable Brackets (F39-LGTB) and Standard Adjustable Brackets (F39-LGA)

Dimensions when using the F3SG-RE Series except the F3SG-4RE0190□30 and F3SG-4RE0160□14

Refer to *Safety Light Curtain F3SG-R Series User's Manual* for the dimensions when using the F3SG-4RE0190□30 and F3SG-4RE0160□14.

### Backside Mounting

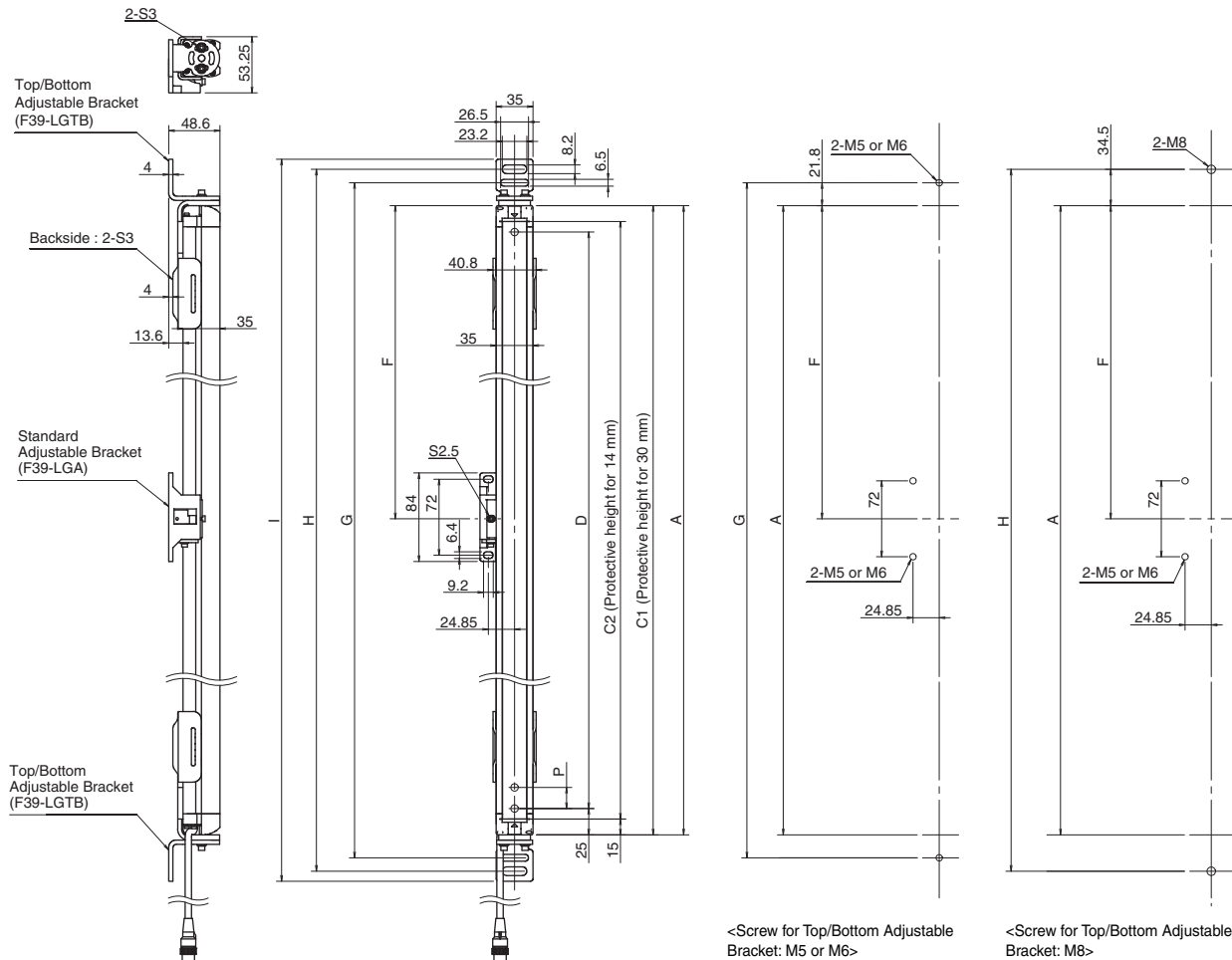

<Screw for Top/Bottom Adjustable Bracket: M5 or M6>

<Screw for Top/Bottom Adjustable Bracket: M8>

#### F3SG-4RE□□□□□30 Series

Dimension A	C1
Dimension C1	4-digit number of the type name (Protective height)
Dimension D	C1-50
Dimension G	C1+43.5
Dimension H	C1+69
Dimension I	C1+88
Dimension P	20

Protective height (C1)	Number of Top/Bottom Adjustable Brackets *1	Number of Standard Adjustable Brackets *1 *2	Dimension F
0270 to 1070	2	0	-
1150 to 1950	2	1	1000 mm max.
2030 to 2510	2	2	1000 mm max.

#### F3SG-4RE□□□□□14 Series

Dimension A	C2+30
Dimension C2	4-digit number of the type name (Protective height)
Dimension D	C2-20
Dimension G	C2+73.5
Dimension H	C2+99
Dimension I	C2+118
Dimension P	10

Protective height (C2)	Number of Top/Bottom Adjustable Brackets *1	Number of Standard Adjustable Brackets *1 *2	Dimension F
0240 to 1040	2	0	-
1120 to 1920	2	1	1000 mm max.
2000 to 2080	2	2	1000 mm max.

\*1.The number of brackets required to mount either one of emitter and receiver.

\*2.The Top/Bottom Adjustable Bracket is not useable together with the Standard Fixed Bracket. When it is necessary to use it with another bracket, only the combination with the Standard Adjustable Bracket is possible.

## Side Mounting

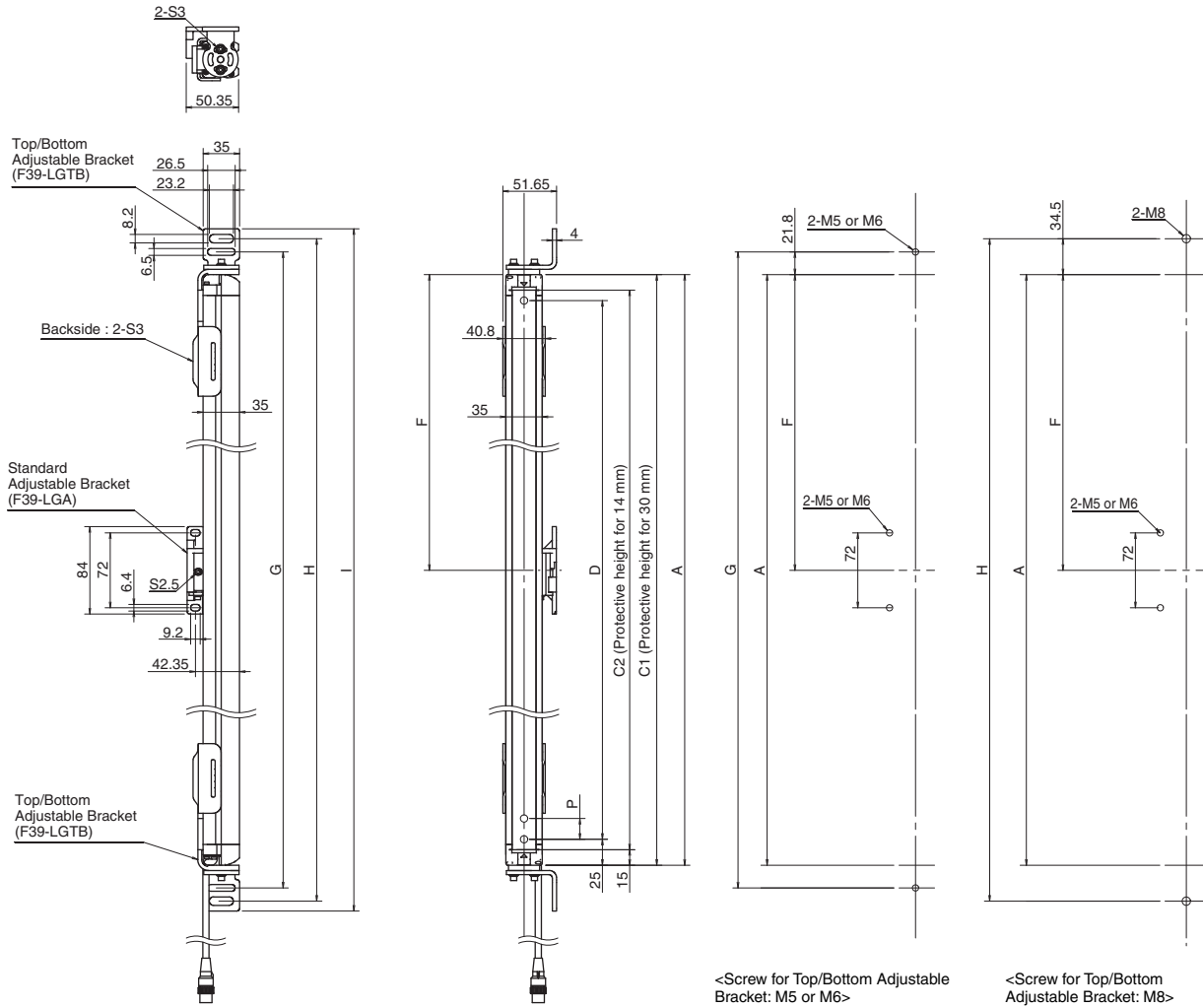

### F3SG-4RE□□□□30 Series

<b>Dimension A</b>	C1
<b>Dimension C1</b>	4-digit number of the type name (Protective height)
<b>Dimension D</b>	C1-50
<b>Dimension G</b>	C1+43.5
<b>Dimension H</b>	C1+69
<b>Dimension I</b>	C1+88
<b>Dimension P</b>	20

Protective height (C1)	Number of Top/Bottom Adjustable Brackets	Number of Standard Adjustable Brackets	Dimension F
0270 to 1070	2	0	-
1150 to 1950	2	1	1000 mm max.
2030 to 2510	2	2	1000 mm max.

### F3SG-4RE□□□□14 Series

<b>Dimension A</b>	C2+30
<b>Dimension C2</b>	4-digit number of the type name (Protective height)
<b>Dimension D</b>	C2-20
<b>Dimension G</b>	C2+73.5
<b>Dimension H</b>	C2+99
<b>Dimension I</b>	C2+118
<b>Dimension P</b>	10

Protective height (C2)	Number of Top/Bottom Adjustable Brackets	Number of Standard Adjustable Brackets	Dimension F
0240 to 1040	2	0	-
1120 to 1920	2	1	1000 mm max.
2000 to 2080	2	2	1000 mm max.

## Accessories

### Sensor Mounting Brackets

#### Standard Fixed Bracket (F39-LGF)

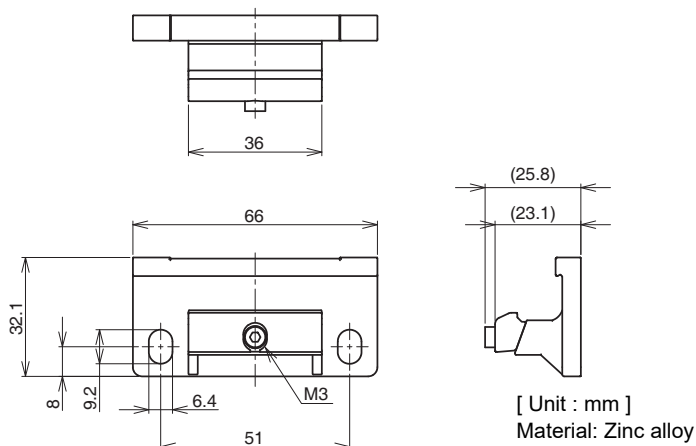

#### Standard Adjustable Bracket (F39-LGA, sold separately)

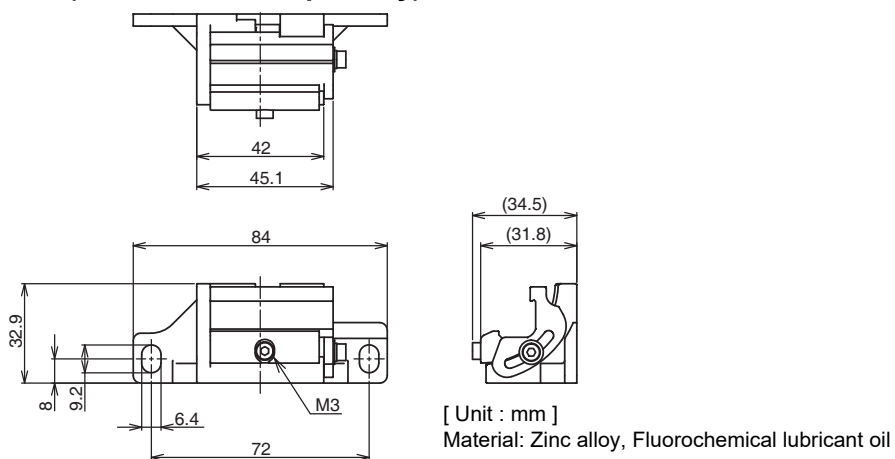

#### Top/Bottom Adjustable Bracket (F39-LGTB, sold separately)

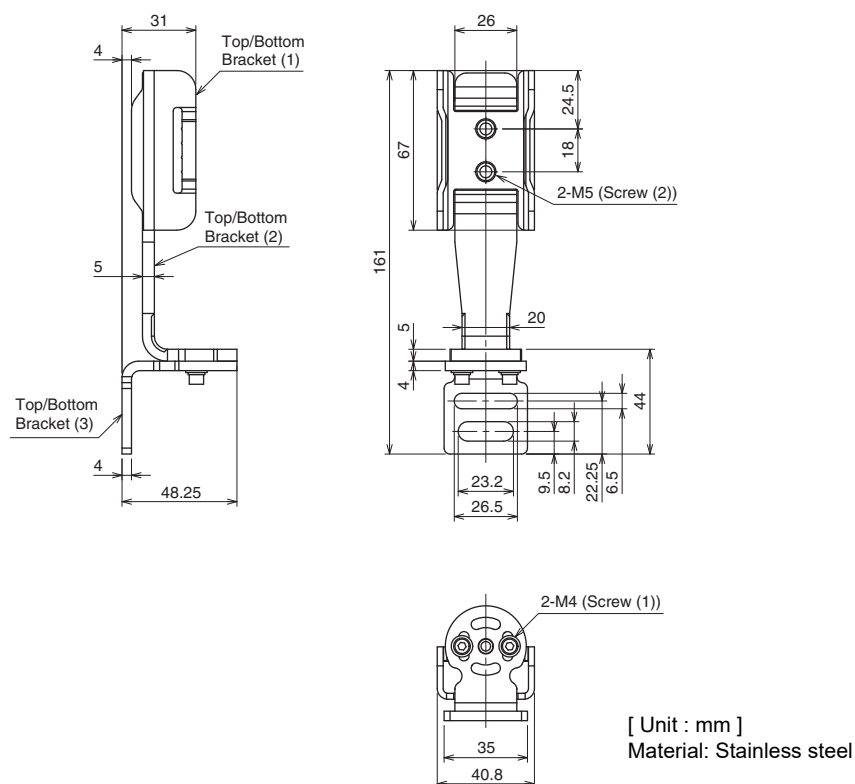

F3SG-RE

# F3SG-RE

## Safety light curtain connecting cable

### Round Water-resistant Connector: Connector Connected to Cable, Socket on One Cable End (XS5F-D421-□80-F, sold separately)

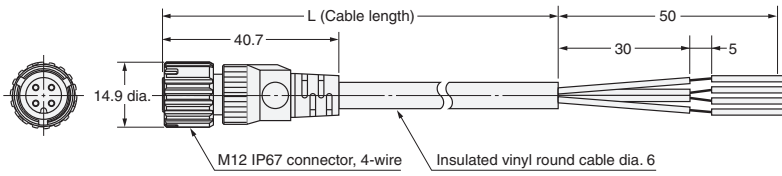

Material: Insulated vinyl round cable

Specification	Model	L (m)
Fire-retardant, Robot cable	XS5F-D421-C80-F	1
	XS5F-D421-D80-F	2
	XS5F-D421-E80-F	3
	XS5F-D421-G80-F	5
	XS5F-D421-J80-F	10
	XS5F-D421-L80-F	20

### Round Water-resistant Connector: Connectors Connected to Cable, Socket and Plug on Cable Ends (XS5W-D421-□81-F, sold separately)

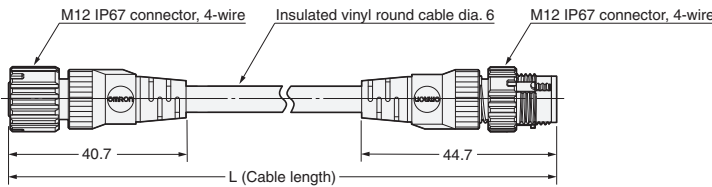

Material: Insulated vinyl round cable

Specification	Model	L (m)
Fire-retardant, Robot cable	XS5W-D421-C81-F	1
	XS5W-D421-D81-F	2
	XS5W-D421-E81-F	3
	XS5W-D421-G81-F	5
	XS5W-D421-J81-F	10
	XS5W-D421-L81-F	20

### Y-Joint Plug/Socket Connector (F39-GCNY1, sold separately)

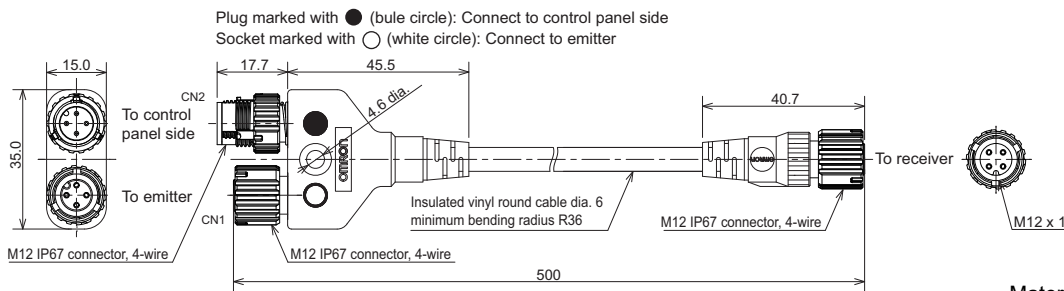

Material: PBT (Main body)

### Spatter Protection Cover(F39-HGA/-HGB, sold separately)

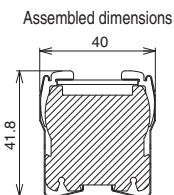

Model	Total length
F39-HGB□□□□	□□□□+6
F39-HGA0550	558

Material: PC (Transparent cover)  
 ABS (Side wall)  
 Stainless steel (Bracket)  
 Aluminum adhesive tape  
 (Fixing sticker)

### Related Manuals

ManNo.	Model	Manual name
Z352	F3SG-□R□□□□□□□□	Safety Light Curtain F3SG-□R Series User's Manual

# Safety Light Curtain

# F3SG-RA-01TS

## Offers Both Durability and Reliability

- Rugged and compact
- All models designed for global use. PNP/NPN selection by DIP switch
- Conforming to major international standards
- Prevents accidental changes of settings by configuration tool (monitoring only)



## System Configuration

### Mounting bracket



### Accessory

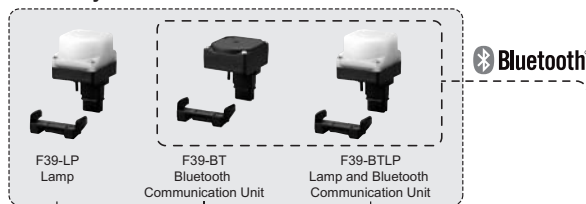

### Accessory

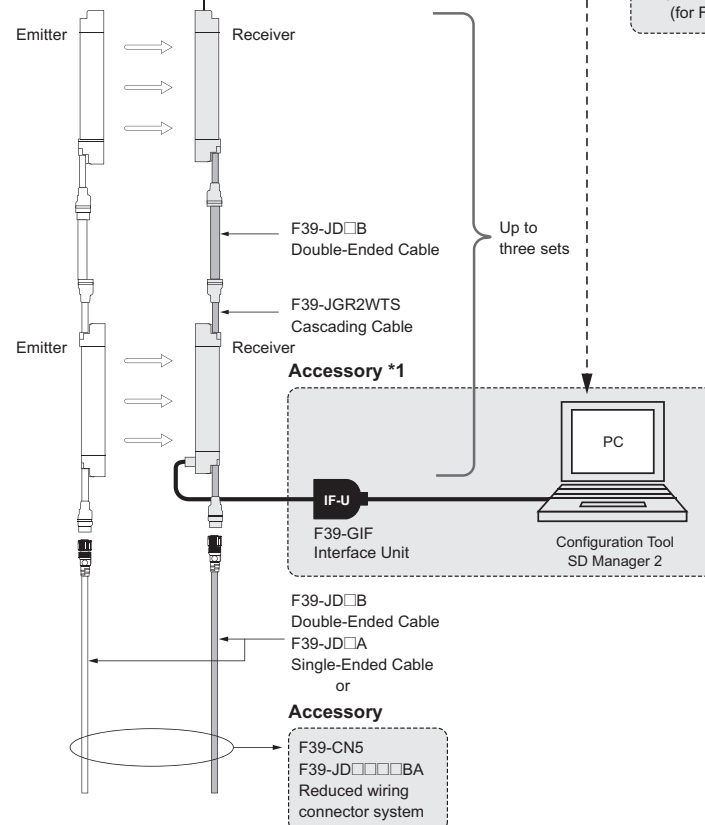
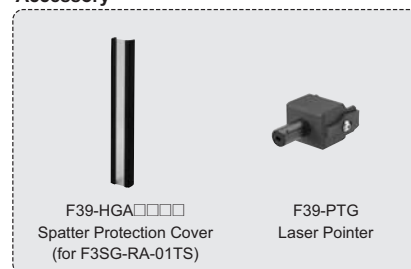

### Recommended safety controller \*2

- NX/NE1A-series Safety Network Controller
- G9SP-series Safety Controller
- G9SE/G9SA-series Safety Relay Unit
- G9SX-series Flexible Safety Unit
- G7SA/G7S-E Relays with Forcibly Guided Contacts

\*1. The F3SG-RA-01TS provides only the monitoring functionality.

\*2. The recommended safety controller is required to build a safety circuit using emergency stop switches and door switches.

F3SG-RA-01TS

# F3SG-RA-01TS

## Ordering Information

### Main Units

Safety Light Curtain



Hand and arm protection

Number of beams	Protective height (mm)	Model
8	185	F3SG-4RA0185-25-01TS
12	265	F3SG-4RA0265-25-01TS
16	345	F3SG-4RA0345-25-01TS
20	425	F3SG-4RA0425-25-01TS
24	505	F3SG-4RA0505-25-01TS
28	585	F3SG-4RA0585-25-01TS
32	665	F3SG-4RA0665-25-01TS
36	745	F3SG-4RA0745-25-01TS
40	825	F3SG-4RA0825-25-01TS
44	905	F3SG-4RA0905-25-01TS
48	985	F3SG-4RA0985-25-01TS
52	1,065	F3SG-4RA1065-25-01TS
56	1,145	F3SG-4RA1145-25-01TS
60	1,225	F3SG-4RA1225-25-01TS
64	1,305	F3SG-4RA1305-25-01TS
68	1,385	F3SG-4RA1385-25-01TS
72	1,465	F3SG-4RA1465-25-01TS
76	1,545	F3SG-4RA1545-25-01TS
80	1,625	F3SG-4RA1625-25-01TS
84	1,705	F3SG-4RA1705-25-01TS
88	1,785	F3SG-4RA1785-25-01TS
92	1,865	F3SG-4RA1865-25-01TS
96	1,945	F3SG-4RA1945-25-01TS

### Accessories (Sold separately)

Safety light curtain connecting cable

Single-Ended Cable (2 cables per set, one for emitter and one for receiver) \*

Appearance	Cable length	Specifications	Model																											
	3m	For emitter M12 connector (8-pin), Color: Gray Connected to Power Cable or Double-Ended Cable  <table border="1"> <tr><td>1</td><td>Not used</td><td>White</td></tr> <tr><td>2</td><td>+24 VDC</td><td>Brown</td></tr> <tr><td>3</td><td>TEST</td><td>Black</td></tr> <tr><td>4</td><td>Not used</td><td>Yellow</td></tr> <tr><td>5</td><td>Not used</td><td>Gray</td></tr> <tr><td>6</td><td>Not used</td><td>Pink</td></tr> <tr><td>7</td><td>0 VDC</td><td>Blue</td></tr> <tr><td>8</td><td>Not used</td><td>Red</td></tr> <tr><td colspan="3">Shield</td></tr> </table>	1	Not used	White	2	+24 VDC	Brown	3	TEST	Black	4	Not used	Yellow	5	Not used	Gray	6	Not used	Pink	7	0 VDC	Blue	8	Not used	Red	Shield			F39-JD3A
	1	Not used	White																											
	2	+24 VDC	Brown																											
	3	TEST	Black																											
	4	Not used	Yellow																											
5	Not used	Gray																												
6	Not used	Pink																												
7	0 VDC	Blue																												
8	Not used	Red																												
Shield																														
7m	For receiver M12 connector (8-pin), Color: Gray Connected to Power Cable or Double-Ended Cable  <table border="1"> <tr><td>1</td><td>OSSD 2</td><td>White</td></tr> <tr><td>2</td><td>+24 VDC</td><td>Brown</td></tr> <tr><td>3</td><td>OSSD 1</td><td>Black</td></tr> <tr><td>4</td><td>AUX</td><td>Yellow</td></tr> <tr><td>5</td><td>Not used</td><td>Gray</td></tr> <tr><td>6</td><td>Not used</td><td>Pink</td></tr> <tr><td>7</td><td>0 VDC</td><td>Blue</td></tr> <tr><td>8</td><td>EDM</td><td>Red</td></tr> <tr><td colspan="3">Shield</td></tr> </table>	1	OSSD 2	White	2	+24 VDC	Brown	3	OSSD 1	Black	4	AUX	Yellow	5	Not used	Gray	6	Not used	Pink	7	0 VDC	Blue	8	EDM	Red	Shield			F39-JD7A	
1	OSSD 2	White																												
2	+24 VDC	Brown																												
3	OSSD 1	Black																												
4	AUX	Yellow																												
5	Not used	Gray																												
6	Not used	Pink																												
7	0 VDC	Blue																												
8	EDM	Red																												
Shield																														
10m		F39-JD10A																												
15m		F39-JD15A																												
20m		F39-JD20A																												

\* The cable for emitter and the cable for receiver are available separately. Add '-L' for emitter or '-D' for receiver to the end of the model number when you order.

Single-Ended Cable for Emitter: F39-JD□A-L, Single-Ended Cable for Receiver: F39-JD□A-D

**Note:** To extend the cable length to more than 20 m, add the F39-JD□B Double-Ended Cable.

**Doble-Ended Cable (2 cables per set, one for emitter and one for receiver) \***  
**For cable extension**

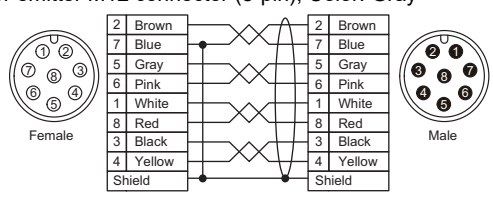
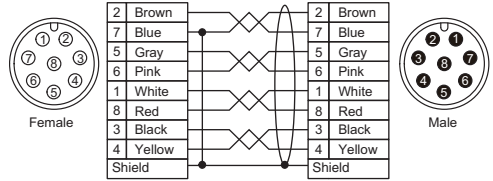
Appearance	Cable length	Specifications	Model
	0.5 m	For emitter M12 connector (8-pin), Color: Gray	<b>F39-JDR5B</b>
	1 m		<b>F39-JD1B</b>
	3 m		<b>F39-JD3B</b>
	5 m	For receiver M12 connector (8-pin), Color: Black Connected to Power Cable or Double-Ended Cable 	<b>F39-JD5B</b>
	7 m		<b>F39-JD7B</b>
	10 m		<b>F39-JD10B</b>
	15 m		<b>F39-JD15B</b>
	20 m	<b>F39-JD20B</b>	

\* The cable for emitter and the cable for receiver are available separately. Add '-L' for emitter or '-D' for receiver to the end of the model number when you order.

Double-Ended Cable for Emitter: F39-JD(R)□B-L, Double-Ended Cable for Receiver: F39-JD(R)□B-D

**Note:** To extend the cable length to more than 20 m, add the F39-JD□B Double-Ended Cable to the F39-JD□A Single-Ended Cable.

To extend the cable length to more than 40 m, add several Double-Ended Cables to the Single-Ended Cable.

Example: To extend the cable length to 50 m, connect two F39-JD20B (20 m) cables and one F39-JD10A (10 m) cable.

**<Connection example>**

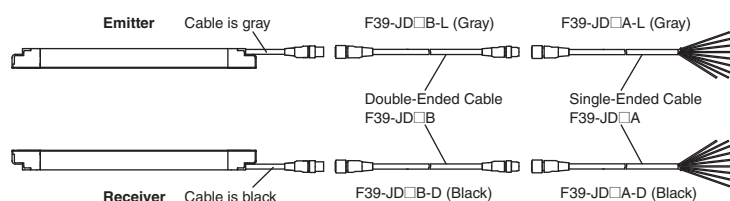

**Cascading Cable (2 cables per set, for emitter and receiver)**

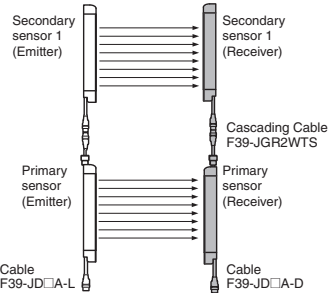
Appearance	Type	Cable length	Specifications	Model
	Cap (8-pin), M12 connector (8-pin)	0.2m		<b>F39-JGR2WTS</b>

**Note:** The Double-Ended Cable (up to 10 m: F39-JD10B) can be added to extend the cable length between the series-connected sensors. Cable length between sensors: 10 m max. (not including cascading cable (F39-JGR2WTS) and power cable)

**<Connection example>**

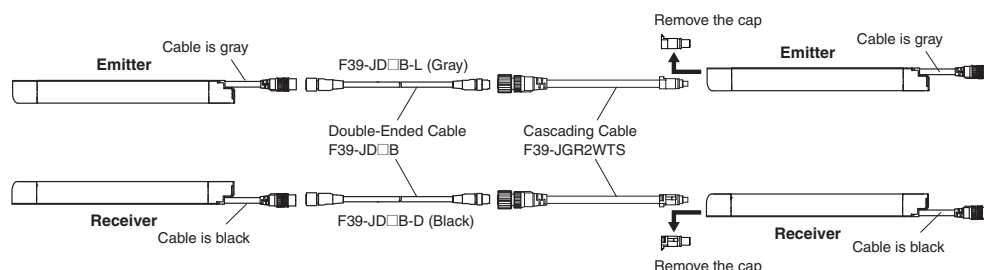

F3SG-RA-01TS

# F3SG-RA-01TS

## Reduced Wiring Connector System (Order the F39-CN5 and Cables for Reduce Wiring.) Reduced Wiring Connector

Appearance	Specifications	Model
	IP67 rated when mated.	<b>F39-CN5</b>

**Note:** When using the Reduced Wiring Connector (F39-CN5), the following functions are not available.

- External Device Monitoring
- Auxiliary Output

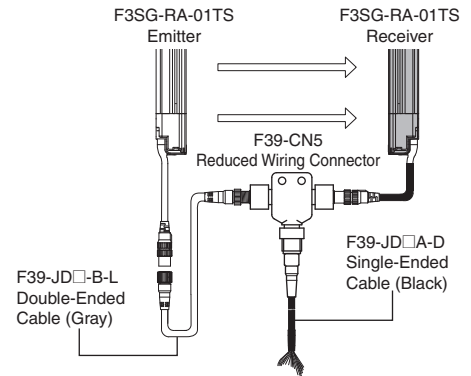





## Cable for Reduce Wiring\* (2 cables per set, one for emitter and one for receiver)

Appearance	Cable length	Specifications	Remarks	Model
	Emitter: 3 m Receiver: 3 m	IP67 rated when mated.	Double-Ended Cable: F39-JD3B-L Single-Ended Cable: F39-JD3A-D	<b>F39-JD0303BA</b>
	Emitter: 3 m Receiver: 7 m		Double-Ended Cable: F39-JD3B-L Single-Ended Cable: F39-JD7A-D	<b>F39-JD0307BA</b>
	Emitter: 3 m Receiver: 10 m		Double-Ended Cable: F39-JD3B-L Single-Ended Cable: F39-JD10A-D	<b>F39-JD0310BA</b>
	Emitter: 5 m Receiver: 3 m		Double-Ended Cable: F39-JD5B-L Single-Ended Cable: F39-JD3A-D	<b>F39-JD0503BA</b>
	Emitter: 5 m Receiver: 7 m		Double-Ended Cable: F39-JD5B-L Single-Ended Cable: F39-JD7A-D	<b>F39-JD0507BA</b>
	Emitter: 5 m Receiver: 10m		Double-Ended Cable: F39-JD5B-L Single-Ended Cable: F39-JD10A-D	<b>F39-JD0510BA</b>
	Emitter: 10 m Receiver: 3 m		Double-Ended Cable: F39-JD10B-L Single-Ended Cable: F39-JD3A-D	<b>F39-JD1003BA</b>
	Emitter: 10 m Receiver: 7 m		Double-Ended Cable: F39-JD10B-L Single-Ended Cable: F39-JD7A-D	<b>F39-JD1007BA</b>
	Emitter: 10 m Receiver: 10 m		Double-Ended Cable: F39-JD10B-L Single-Ended Cable: F39-JD10A-D	<b>F39-JD1010BA</b>

**Note:** A combination of emitter and receiver cables of other lengths than the above is also available. For details, contact your Omron representative.  
\* Double-Ended Cable for emitter and Single-Ended Cable for receiver.

## Sensor Mounting Brackets

Appearance	Specification	Application	Model
	Standard Fixed Bracket	Bracket to mount the F3SG-RA-01TS. Side mounting and backside mounting possible. (Sold separately as a set of two Brackets. Refer to note *1 for the number of sets required for each model.)	<b>F39-LGF</b>
	Standard Adjustable Bracket	Bracket to mount the F3SG-RA-01TS. Beam alignment after mounting possible. The angle adjustment range is $\pm 15^\circ$ . Side mounting and backside mounting possible. (Sold separately as a set of two Brackets. Refer to note *1 for the number of sets required for each model.)	<b>F39-LGA</b>
	Top/Bottom Adjustable Bracket *2	Bracket to mount the F3SG-RA-01TS. Use this bracket at the top and bottom positions of the F3SG-RA-01TS. Beam alignment after mounting possible. The angle adjustment range is $\pm 22.5^\circ$ . Side mounting and backside mounting possible. (Sold separately. 4 brackets per set.)	<b>F39-LGTB</b>
	Top/Bottom Adjustable Bracket *2 (For user-made mounting part)	Top/Bottom Adjustable Bracket without a bracket to mount to the wall. Use the user's own wall mounting part to suit the machine. (Sold separately. 4 brackets per set.)	<b>F39-LGTB-1</b>

\*1. Protective height of 0185 to 1225: 2 sets, Protective height of 1305 to 1945: 3 sets



\*2. Top/Bottom Adjustable Bracket cannot be used with the Standard Fixed Bracket. Use with the Standard Adjustable Bracket.

Using Top/Bottom Adjustable Brackets with Standard Adjustable Brackets

Protective height of 1065 or less: The Standard Adjustable Bracket is not required. Please purchase 1 set of Top/Bottom Adjustable Brackets (F39-LGTB(-1)).

Protective height of 1145 to 1945: Please purchase 1 set of Top/Bottom Adjustable Brackets (F39-LGTB(-1)) and 1 set of Standard Adjustable Brackets (F39-LGA).

**Interface units and configuration tool SD Manager 2 \***

Appearance	Type	Specifications	Model
	SD Manager 2	The Configuration Tool SD Manager 2 is available to download from our website at <a href="http://www.ia.omron.com/f3sg-r_tool">http://www.ia.omron.com/f3sg-r_tool</a> .	—
	Interface Unit	F39-GIF interface unit to connect the F3SG-RA-01TS receiver to a USB port of the PC  Accessories: 0.3-m Dedicated Cable 1 (1), 2-m Dedicated Cable 2 (1), Instruction Manual	<b>F39-GIF</b>
	Bluetooth Communication Unit	F39-BT bluetooth unit to enable bluetooth on the F3SG-RA  IP67 rated when mated.	<b>F39-BT</b>

\* The F3SG-RA-01TS provides only the monitoring functionality.

**Lamp**

Appearance	Type	Specifications	Model
	Lamp	The lamp can be connected to a receiver and turned ON based on the operation of F3SG-RA.  The lamp output pattern is set as follows: Red (ON): Inverted signal of safety output information Orange (Blink once): Inverted signal of stable-state information	<b>F39-LP</b>
	Lamp and Bluetooth Communication Unit	Green (ON): Safety output information  IP67 rated when mated.	<b>F39-BTLP</b>

**End Cap \***

Appearance	Specifications	Model
	Housing color: Black For both emitter and receiver (Attached to the F3SG-RA-01TS. The End Cap can be purchased if lost.)  IP67 rated when mated.	<b>F39-CNM</b>

\* This accessory can also be used with the F3SG-RA-02TS.

**Laser Pointer for F3SG-R**

Appearance	Specifications	Model
	The laser pointer is attached on the optical surface of the F3SG-R to help coarse adjustment of beams.	<b>F39-PTG</b>

# F3SG-RA-01TS

## Spatter Protection Cover (2 covers per set, one for emitter and one for receiver)

Spatter Protection Covers include mounting brackets.

Appearance	Safety Light Curtain Model	Model
	Hand protection	
	F3SG-4RA0185-25-01TS	F39-HGA0200
	F3SG-4RA0265-25-01TS	F39-HGA0280
	F3SG-4RA0345-25-01TS	F39-HGA0360
	F3SG-4RA0425-25-01TS	F39-HGA0440
	F3SG-4RA0505-25-01TS	F39-HGA0520
	F3SG-4RA0585-25-01TS	F39-HGA0600
	F3SG-4RA0665-25-01TS	F39-HGA0680
	F3SG-4RA0745-25-01TS	F39-HGA0760
	F3SG-4RA0825-25-01TS	F39-HGA0840
	F3SG-4RA0905-25-01TS	F39-HGA0920
	F3SG-4RA0985-25-01TS	F39-HGA1000
	F3SG-4RA1065-25-01TS	F39-HGA1080
	F3SG-4RA1145-25-01TS	F39-HGA1160
	F3SG-4RA1225-25-01TS	F39-HGA1240
	F3SG-4RA1305-25-01TS	F39-HGA1320
	F3SG-4RA1385-25-01TS	F39-HGA1400
	F3SG-4RA1465-25-01TS	F39-HGA1480
	F3SG-4RA1545-25-01TS	F39-HGA1560
	F3SG-4RA1625-25-01TS	F39-HGA1640
	F3SG-4RA1705-25-01TS	F39-HGA1720
F3SG-4RA1785-25-01TS	F39-HGA1800	
F3SG-4RA1865-25-01TS	F39-HGA1880	
F3SG-4RA1945-25-01TS	F39-HGA1960	

- Note:**
1. The operating range of the Safety Light Curtain attached with the product is 10% shorter than the rating.
  2. The product extends over the DIP Switch cover of the Safety Light Curtain. Be sure to use the product only after all required settings are made to the DIP Switch.

### Test Rod

Diameter	Model
25 mm dia.	F39-TRD25

## Ratings and Specifications

### Main unit

The □□□□ in the model names indicate the protective heights in millimeters.

		F3SG-4RA□□□□-25-01TS		
Performance	Object Resolution (Detection Capability)	Opaque objects 25-mm dia.		
	Beam Gap	20 mm		
	Number of Beams	8 to 96		
	Lens Size	6.0×5.0 (W×H) mm		
	Protective Height	185 to 1945 mm (7.3 to 76.6 inch)		
	Operating Range	Long	0.3 to 17.0 m (1 to 56 ft.)	
		Short	0.3 to 5.0 m (1 to 16 ft.)	
	Response Time	ON to OFF	8 to 13 ms *1	
		OFF to ON	40 to 65ms *1	
		*1. Response time when used in one segment system or in cascaded connection. Refer to page 101 for the one segment system. Refer to <i>Safety Light Curtain F3SG-4RA□□□□-25-01TS Series User's Manual (ManNo.: Z380)</i> for cascaded connection.		
	Effective Aperture Angle (EAA) (IEC 61496-2)	Type 4	±2.5° max., emitter and receiver at operating range of 3 m or greater	
Light Source	Infrared LEDs, Wavelength: 870 nm			
Startup Waiting Time	2 s max.			
Electrical	Power Supply Voltage (Vs)	SELV/PELV 24 VDC±20% (ripple p-p 10% max.)		
	Current Consumption	Refer to page 101 .		
	Safety Outputs (OSSD)	Two PNP or NPN transistor outputs (PNP or NPN is selectable by DIP Switch.) Load current of 300 mA max., Residual voltage of 2 V max. (except for voltage drop due to cable extension), Capacitive load of 1 µF max., Inductive load of 2.2 H max. *1 Leakage current of 1 mA max. (PNP), 2 mA max. (NPN) *2		
		*1. The load inductance is the maximum value when the safety output frequently repeats ON and OFF. When you use the safety output at 4 Hz or less, the usable load inductance becomes larger. *2. These values must be taken into consideration when connecting elements including a capacitive load such as a capacitor.		
	Auxiliary Output	One PNP or NPN transistor output (Safety Output and homopolarity) Load current of 100 mA max., Residual voltage of 2 V max		
	Output Operation Mode	Safety Output	Light-ON (Safety output is enabled when the receiver receives an emitting signal.)	
		Auxiliary Output	Reverse output of safety output	
	Input Voltage	External device monitoring input (Lockout reset input)	PNP ON voltage: Vs-3 V to Vs (short circuit current: approx. 6.5 mA) * OFF voltage: 0 V to 1/2 Vs, or open (short circuit current: approx. 8.0 mA) *	
			NPN ON voltage: 0 to 3 V (short circuit current: approx. 8.0 mA) * OFF voltage: 1/2 Vs to Vs, or open (short circuit current: approx. 6.5 mA) *	
		Test input	24 V inactive setting ON voltage: 0 to 3 V or open (short circuit current: approx. 2.0 mA) OFF voltage: 9 V to Vs (short circuit current: approx. 2.5 mA) * 0 V inactive setting ON voltage: 9 V to Vs or open (short circuit current: approx. 2.5 mA) OFF voltage: 0 to 3 V (short circuit current: approx. 2.0 mA) * The Vs indicates a supply voltage value in your environment.	
	Overvoltage Category (IEC 60664-1)	II		
Indicators	Refer to page 103 .			
Protective Circuit	Output short protection, Power supply reverse polarity protection			
Insulation Resistance	20 MΩ or higher (500 VDC megger)			
Dielectric Strength	1,000 VAC, 50/60 Hz (1 min)			
Functional	Mutual Interference Prevention (Scan Code)	This function prevents mutual interference in up to two F3SG-RA systems.		
	Cascade Connection	Number of cascaded segments: 3 max. Total number of beams: 255 max. Cable length between sensors: 10 m max. (not including cascading cable (F39-JGR2WTS) and power cable)		
	Test Function	Self-test (at power-on, and during operation) External test (light emission stop function by test input)		
	Safety-Related Functions	External device monitoring (EDM) Scan code selection PNP/NPN selection		

# F3SG-RA-01TS

			F3SG-4RA□□□□-25-01TS
Environmental	Ambient Temperature	Operating	-10 to 55°C (14 to 131°F) (non-icing)
		Storage	-25 to 70°C (-13 to 158°F)
	Ambient Humidity	Operating	35% to 85% (non-condensing)
		Storage	35% to 95%
	Ambient Illuminance		Incandescent lamp: 3,000 lx max. on receiver surface Sunlight: 10,000 lx max. on receiver surface
	Degree of Protection (IEC 60529)		IP65 and IP67
	Vibration Resistance (IEC 61496-1)		Class 3M4 (IEC TR 60721-4-3) Operation limit: 5 to 150 Hz, Multiple amplitude of 7 mm, Acceleration of 1 G, 10 sweeps each in X, Y, and Z directions (no delay at resonant frequencies)
Shock Resistance (IEC 61496-1)		Class 3M4 (IEC TR 60721-4-3) Operation limit: Acceleration of 15 G, Pulse duration of 6 ms, 100 shocks for each in X, Y, and Z directions (600 shocks in total)	
Pollution Degree (IEC 60664-1)		Pollution Degree 3	
Connections	Power cable	Type of Connection	M12 connectors: 8-pin emitter and receiver, IP67 rated when mated, Cables pre-wired to the sensors
		Number of Wires	On emitter: 5-wire, On receiver: 8-wire
		Cable Length	0.3 m
		Cable Diameter	6 mm
		Minimum Bending Radius	R5 mm
	Cascading cable	Type of Connection	M12 connectors: 8-pin emitter and receiver, IP67 rated when mated
		Number of Wires	On emitter: 5-wire, On receiver: 8-wire
		Cable Length	0.2 m
		Minimum Bending Radius	R5 mm
	Extension cable - Single-Ended Cable - Double-Ended Cable	Type of Connection	M12 connectors: 8-pin emitter and receiver, IP67 rated when mated
		Number of Wires	On emitter and receiver: 8-wire
		Cable Length	Refer to page 94.
		Minimum Bending Radius	R36 mm
Extension of Power Cable			100 m max.(Emitter/Receiver)
Material	Material	Housing: Aluminum alloy Cap: PBT resin Front window: Acrylic resin Cable: Oil-resistant PVC resin FE plate: Stainless steel	
	Weight	Refer to page 101 .	
	Included Accessories	Safety Precautions, Quick Installation Manual, Troubleshooting Guide Sticker,	
Conformity	Conforming standards	Refer to page 102 .	
	Type of ESPE (IEC 61496-1)	Type 4	
	Performance Level (PL)/ Safety category	PL e/Category 4 (EN ISO 13849-1:2015)	
	PFH <sub>D</sub>	1.1 × 10 <sup>-8</sup> (IEC 61508)	
	Proof test interval T <sub>M</sub>	Every 20 years (IEC 61508)	
	SFF	99% (IEC 61508)	
	HFT	1 (IEC 61508)	
Classification	Type B (IEC 61508-2)		

## Bluetooth Communication Unit

Communication System	Bluetooth Version 3.0
Communication Profile	SPP (Serial Port Profile)
Transmission Distance	Approx. 10 m max. (Output power: Class 2) *

\* It depends on use environment conditions.

## List of Models/Response Time/Current Consumption/Weight

Model	Number of Beams	Protective Height [mm]	Response Time [ms] *1			Current Consumption [mA]		Weight [kg]	
			ON → OFF *2	OFF (Synchronized) → ON	OFF (Not synchronized) → ON	Emitter	Receiver	Net *3	Gross *4
F3SG-4RA0185-25-01TS	8	185	8	40	140	35	75	0.7	1.4
F3SG-4RA0265-25-01TS	12	265	8	40	140	35	75	0.9	1.6
F3SG-4RA0345-25-01TS	16	345	8	40	140	40	75	1.1	1.9
F3SG-4RA0425-25-01TS	20	425	8	40	140	45	75	1.3	2.2
F3SG-4RA0505-25-01TS	24	505	8	40	140	50	75	1.5	2.5
F3SG-4RA0585-25-01TS	28	585	8	40	140	50	75	1.7	2.7
F3SG-4RA0665-25-01TS	32	665	8	40	140	55	75	1.9	3.0
F3SG-4RA0745-25-01TS	36	745	8	40	140	60	80	2.1	3.3
F3SG-4RA0825-25-01TS	40	825	8	40	140	65	80	2.3	3.6
F3SG-4RA0905-25-01TS	44	905	13	65	165	50	80	2.5	3.8
F3SG-4RA0985-25-01TS	48	985	13	65	165	50	80	2.8	4.1
F3SG-4RA1065-25-01TS	52	1065	13	65	165	55	80	3.0	4.4
F3SG-4RA1145-25-01TS	56	1145	13	65	165	55	85	3.2	4.7
F3SG-4RA1225-25-01TS	60	1225	13	65	165	55	85	3.4	5.0
F3SG-4RA1305-25-01TS	64	1305	13	65	165	60	85	3.6	5.2
F3SG-4RA1385-25-01TS	68	1385	13	65	165	60	85	3.8	5.5
F3SG-4RA1465-25-01TS	72	1465	13	65	165	65	85	4.0	5.8
F3SG-4RA1545-25-01TS	76	1545	13	65	165	65	90	4.2	6.0
F3SG-4RA1625-25-01TS	80	1625	13	65	165	70	90	4.4	6.3
F3SG-4RA1705-25-01TS	84	1705	13	65	165	70	90	4.6	6.6
F3SG-4RA1785-25-01TS	88	1785	13	65	165	70	90	4.9	6.9
F3SG-4RA1865-25-01TS	92	1865	13	65	165	75	90	5.1	7.1
F3SG-4RA1945-25-01TS	96	1945	13	65	165	75	95	5.3	7.4

\*1. The maximum speed of movement of a test rod up to which the detection capability is maintained is 2.0 m/s.

\*2. The response times are values when Scan Code is set at Code B. The response times for Code A are 1 ms shorter than these values.

\*3. The net weight is the weight of an emitter and a receiver.

\*4. The gross weight is the weight of an emitter, a receiver, included accessories and a package.

## Legislation and Standards

---

1. The F3SG-RA-01TS does not receive type approval provided by Article 44-2 of the Industrial Safety and Health Act of Japan. When using the F3SG-RA-01TS in Japan as a "safety system for pressing or shearing machines" prescribed in Article 42 of that law, the machine control system must receive type approval.
2. The F3SG-RA-01TS is electro-sensitive protective equipment (ESPE) in accordance with European Union (EU) Machinery Directive Index Annex V, Item 2.
3. EU Declaration of Conformity  
OMRON declares that the F3SG-RA-01TS is in conformity with the requirements of the following EU Directives:  
Machinery Directive 2006/42/EC  
EMC Directive 2014/30/EU
4. Conforming Standards
  - (1) European standards  
EN61496-1 (Type 4 and Type 2 ESPE), EN 61496-2 (Type 4 and Type 2 AOPD), EN61508-1 through -4 (SIL 3 for Type 4 and SIL 1 for Type 2), EN ISO 13849-1:2015 (PL e, Category 4 for Type 4 and PL c, Category 2 for Type 2)
  - (2) International standards  
IEC61496-1 (Type 4 and Type 2 ESPE), IEC61496-2 (Type 4 and Type 2 AOPD), IEC61508-1 through -4 (SIL 3 for Type 4 and SIL 1 for Type 2), ISO 13849-1:2015 (PL e, Category 4 for Type 4 and PL c, Category 2 for Type 2)
  - (3) JIS standards  
JIS B 9704-1 (Type 4 and Type 2 ESPE), JIS B 9704-2 (Type 4 and Type 2 AOPD)
  - (4) North American standards  
UL61496-1 (Type 4 and Type 2 ESPE), UL61496-2 (Type 4 and Type 2 AOPD), UL508, UL1998, CAN/CSA C22.2 No.14, CAN/CSA C22.2 No.0.8
5. Third-Party Certifications
  - (1) TÜV SÜD
    - EC Type-Examination certificate:  
EU Machinery Directive, Type 4 and Type 2 ESPE (EN61496-1), Type 4 and Type 2 AOPD (EN 61496-2)
    - Certificate:  
Type 4 and Type 2 ESPE (EN61496-1), Type 4 and Type 2 AOPD (EN61496-2), EN 61508-1 through -4 (SIL 3 for Type 4 and SIL 1 for Type 2), EN ISO 13849-1:2015 (PL e, Category 4 for Type 4, and PL c, Category 2 for Type 2)
  - (2) UL
    - UL Listing:  
Type 4 and Type 2 ESPE (UL61496-1), Type 4 and Type 2 AOPD (UL61496-2), UL508, UL1998, CAN/CSA C22.2 No.14, CAN/CSA C22.2 No.0.8
6. Other Standards  
The F3SG-RA-01TS is designed according to the standards listed below. To make sure that the final system complies with the following standards and regulations, you are asked to design and use it in accordance with all other related standards, laws, and regulations. If you have any questions, consult with specialized organizations such as the body responsible for prescribing and/or enforcing machinery safety regulations in the location where the equipment is to be used.
  - European Standards: EN415-4, EN691-1, EN692, EN693, IEC 62046
  - U.S. Occupational Safety and Health Standards: OSHA 29 CFR 1910.212
  - U.S. Occupational Safety and Health Standards: OSHA 29 CFR 1910.217
  - American National Standards: ANSI B11.1 to B11.19
  - American National Standards: ANSI/RIA R15.06
  - Canadian Standards Association CSA Z142, Z432, Z434
  - SEMI Standards SEMI S2
  - Japan Ministry of Health, Labour and Welfare "Guidelines for Comprehensive Safety Standards of Machinery", Standard Bureau's Notification No. 0731001 dated July 31, 2007.rms and Conditions Agreement

## Indicator

### Emitter

Name of Indicator	Color	Illuminated	Blinking
TEST	Green	–	External Test is being performed
LONG	Green	Long range mode is selected	Lockout state due to DIP Switch setting error or Operating range selection setting error
POWER	Green	Power is ON.	Error due to noise
LOCKOUT	Red	–	Lockout state due to error in emitter

### Receiver

Name of Indicator	Color	Illuminated	Blinking
TOP	Blue	The top beam is unblocked	Lockout state due to Cap error or Other sensor error
NPN	Green	NPN mode is selected by DIP Switch	–
CFG	Green	–	Lockout state due to Cascading Configuration error
EDM	Green	EDM input is in ON state *	Lockout state due to EDM error
INTERNAL	Red	–	Lockout state due to Internal error, or error due to abnormal power supply or noise
LOCKOUT	Red	–	Lockout state due to error in receiver
STB	Green	Incident light level is 170% or higher of ON-threshold	Safety output is instantaneously turned OFF due to ambient light or vibration
ON/OFF	Green	Safety output is in ON state	–
	Red	Safety output is in OFF state	Lockout state due to Safety Output error, or error due to abnormal power supply or noise
COM	Green	Synchronization between emitter and receiver is maintained	Lockout state due to Communication error, or error due to abnormal power supply or noise
BTM	Blue	The bottom beam is unblocked	Lockout state due to DIP Switch setting error

\* The LED is illuminated when the EDM input is in ON state regardless of wiring with EDM used or unused.

### Interface Unit

Main unit	PC/AT compatible machine (computer that runs Microsoft Windows)
Operating system (OS)	Windows 7 (32-bit/64-bit), Windows 8, 8.1 (32-bit/64-bit), Windows 10 (32-bit/64-bit)
Communication port	USB port x1
Ambient temperature	Operating: -10 to 55°C, Storage: -30 to 70°C(non-icing and non-condensing)
Ambient humidity	Operating: 35% to 85%, Storage: 35% to 95%(non-condensing)

### Lamp

Item	F39-LP
Applicable Sensor	F3SG-□RA Series Safety Light Curtain (Receiver)
LED Light Color	Red/Orange/Green
Power Supply Voltage	24 VDC±20%, ripple p-p 10% max.(shares sensor's power supply)
Current Consumption	25 mA max. (shares sensor's power supply.)
Ambient Temperature	Operating: -10 to 55°C, Storage: -25 to 70°C
Ambient Humidity	Operating: 35% to 85%, Storage: 35% to 95%
Vibration Resistance	10 to 55 Hz, Multiple amplitude of 0.7 mm,20 sweeps for all 3 axes
Shock Resistance	100 m/s <sup>2</sup> , 1000 shocks for all 3 axes
Degree of Protection	IP65 and IP67(When attached to F3SG)
Type of Connection	Connectable to F3SG-RA's terminal connector
Material	Lighting element: PC, Other body parts: PBT
Weight	45 g (when packaged)

# F3SG-RA-01TS

## Connections (Basic Wiring Diagram)

### Standalone F3SG-RA-01TS using PNP Outputs

#### EDM disabled, External Test unused and PNP Outputs

The following is the example of EDM disabled, PNP outputs and External Test unused.

#### DIP Switch settings \*1

	Function	DIP-SW1	DIP-SW2
Receiver	EDM Disabled (factory default setting)	2 <input checked="" type="checkbox"/> ON	2 <input checked="" type="checkbox"/> ON
	PNP (factory default setting)	7 <input checked="" type="checkbox"/> ON	7 <input checked="" type="checkbox"/> ON
Emitter	External Test: 24 V Inactive (factory default setting)	4 <input checked="" type="checkbox"/> ON	

: Indicates a switch position.

Configure functions with the DIP Switches before wiring.

#### Wiring Example

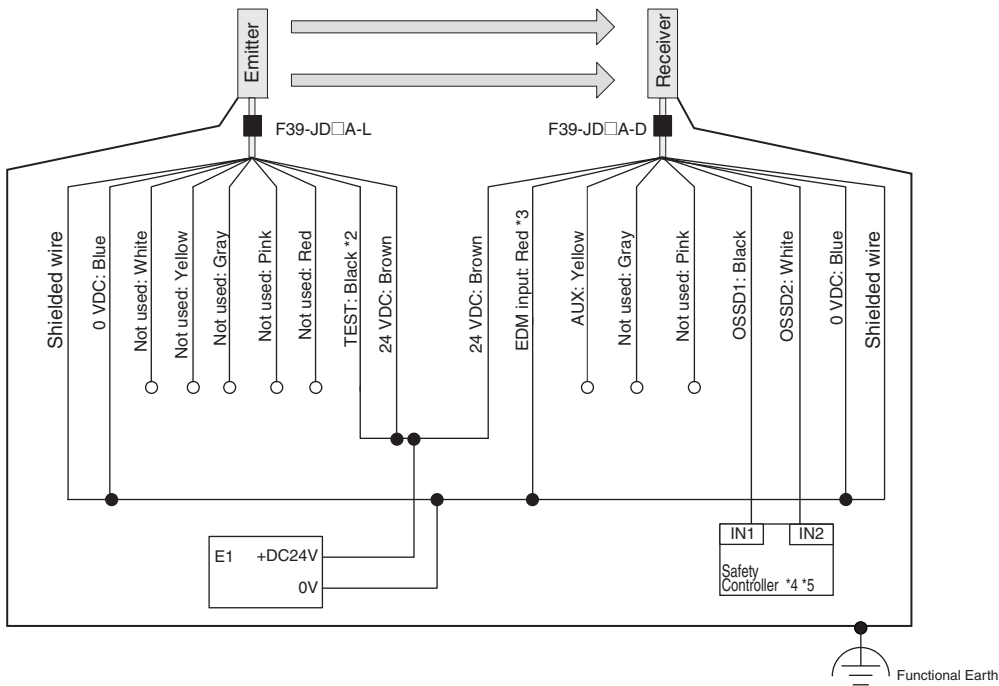

\*1. The functions are configurable with DIP Switch. Refer to *Safety Light Curtain F3SG-4RA□□□□-25-01TS Series User's Manual* for more information on setting the functions by the DIP Switch.

\*2. When the external test function is used, connect to 24V via the test switch (NC contact).

\*3. Also used for the lockout reset input. When using the lockout reset function, connect to 24V via lockout reset switch (NC contact).

\*4. Refer to page 106 for more information.

\*5. The safety controller and the F3SG-RA must share the power supply or be connected to the common terminal of the power supply.

E1: 24VDC power supply (S8VS)

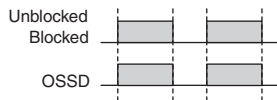

**Note:** Functional earth connection is unnecessary when you use the F3SG-RA-01TS in a general industrial environment where noise control or stable power supply is considered. However, when you use the F3SG-RA-01TS in an environment where there may be excessive noise from surroundings or stable power supply may be interfered, it is recommended the F3SG-RA-01TS be connected to functional earth. The wiring examples in later examples do not indicate functional earth. To use functional earth, wire an earth cable according to the example above. Refer to *Safety Light Curtain F3SG-4RA□□□□-25-01TS Series User's Manual* for more information.

## Standalone F3SG-RA-01TS using NPN Outputs

### EDM enabled, External Test 0V Inactive and NPN Outputs

The following is the example of External Device Monitoring enabled, NPN outputs and External Test in 0 V Inactive.

#### DIP Switch settings \*1

	Function	DIP-SW1	DIP-SW2
Receiver	EDM Enabled	2 <input checked="" type="checkbox"/> ON	2 <input checked="" type="checkbox"/> ON
	NPN	7 <input checked="" type="checkbox"/> ON	7 <input checked="" type="checkbox"/> ON
Emitter	External Test: 0 V Inactive	4 <input checked="" type="checkbox"/> ON	

: Indicates a switch position.

Configure functions with the DIP Switches before wiring.

#### Wiring Example

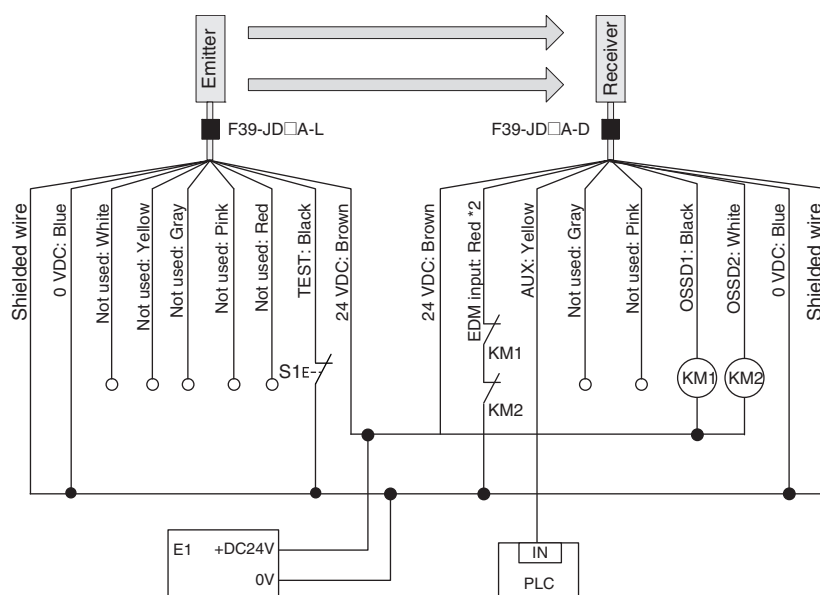

\*1. The functions are configurable with DIP Switch. Refer to *Safety Light Curtain F3SG-4RA□□□□-25-01TS Series User's Manual* for more information on setting the functions by the DIP Switch.

\*2. Also used for the lockout reset input. When using the lockout reset function connect to 0V via lockout reset switch (NC contact).

- S1: Test switch(connect to 0V if a switch is not required)
- KM1, KM2: Safety relay with forcibly guided contacts (G7SA) or magnetic contactor
- E1: 24VDC power supply (S8VS)
- PLC: Programmable controller (Used for monitoring -- not related to safety system)

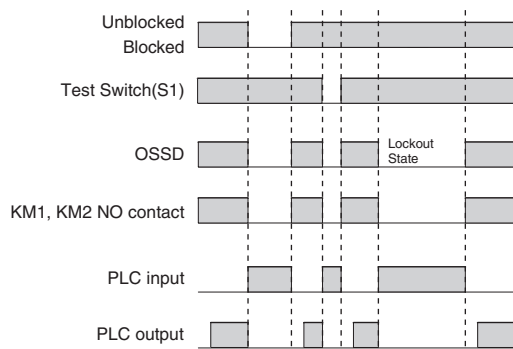

**Note:** For the functional earth connection, refer to page 104.

F3SG-RA-01TS

## Connectable Safety Control Units

The F3SG-RA-01TS with PNP output can be connected to the safety control units listed in the table below.

Connectable Safety Control Units (PNP output)		
Safety Relay Units	Flexible Safety Units	Safety Controllers
G9SA-301 G9SA-321-T□ G9SA-501 G9SB-200-B G9SB-200-D G9SB-301-B G9SB-301-D G9SE-201 G9SE-401 G9SE-221-T□	G9SX-AD322-T G9SX-ADA222-T G9SX-BC202 G9SX-GS226-T15	G9SP-N10S G9SP-N10D G9SP-N20S NE0A-SCPU01 NE1A-SCPU01 NE1A-SCPU02 DST1-ID12SL-1 DST1-MD16SL-1 DST1-MRD08SL-1 NX-SIH400 NX-SID800 F3SP-T01

The F3SG-R with NPN output can be connected to the safety control unit listed in the table below.

Connectable Safety Control Units (NPN output)
Safety Relay Units
G9SA-301-P

# Input/Output Circuit

## Entire Circuit Diagram

The entire circuit diagram of the F3SG-RA-01TS is shown below. The numbers in the circles indicate the connector's pin numbers.

## PNP Output

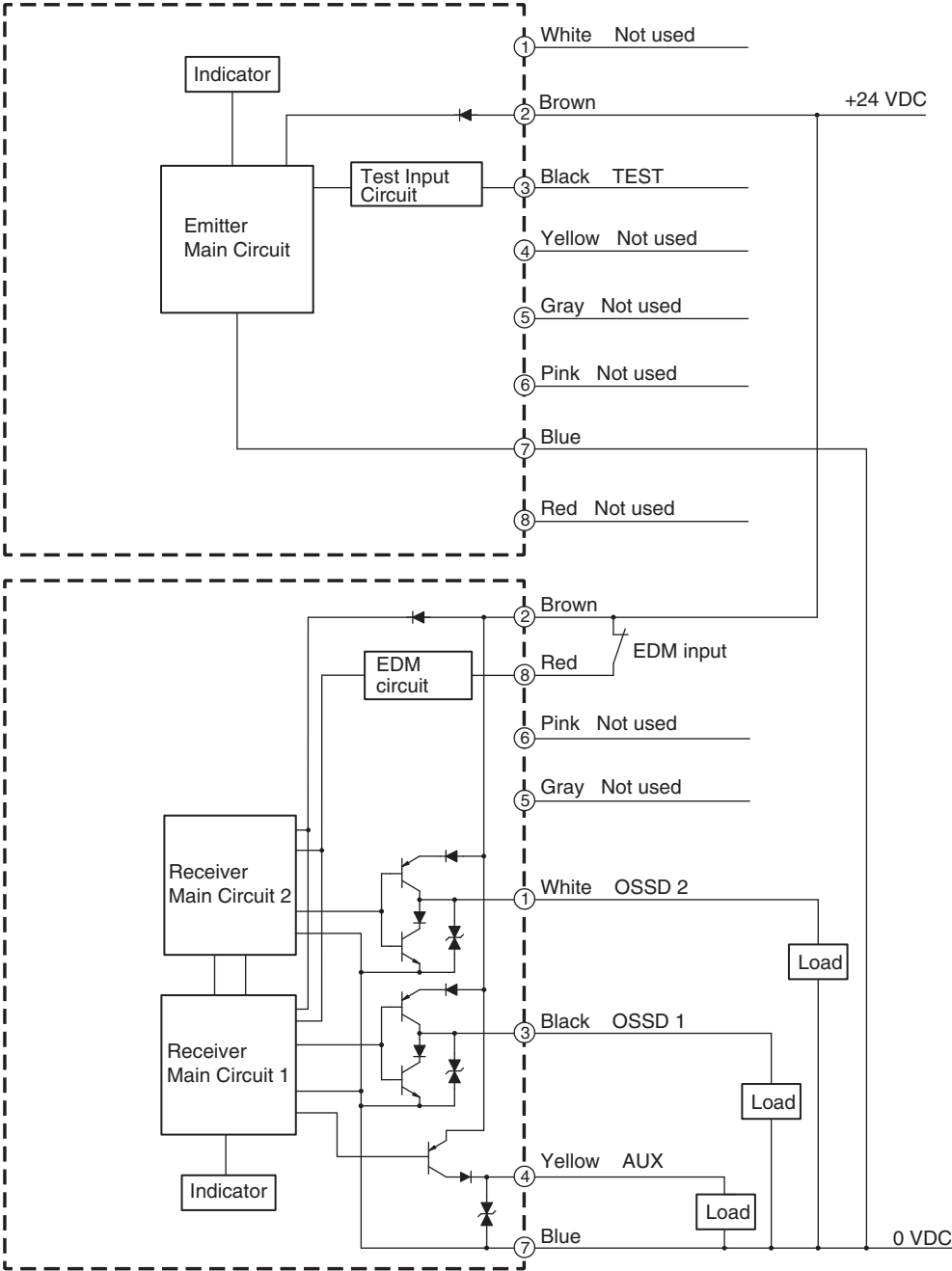

F3SG-RA-01TS

## NPN Output

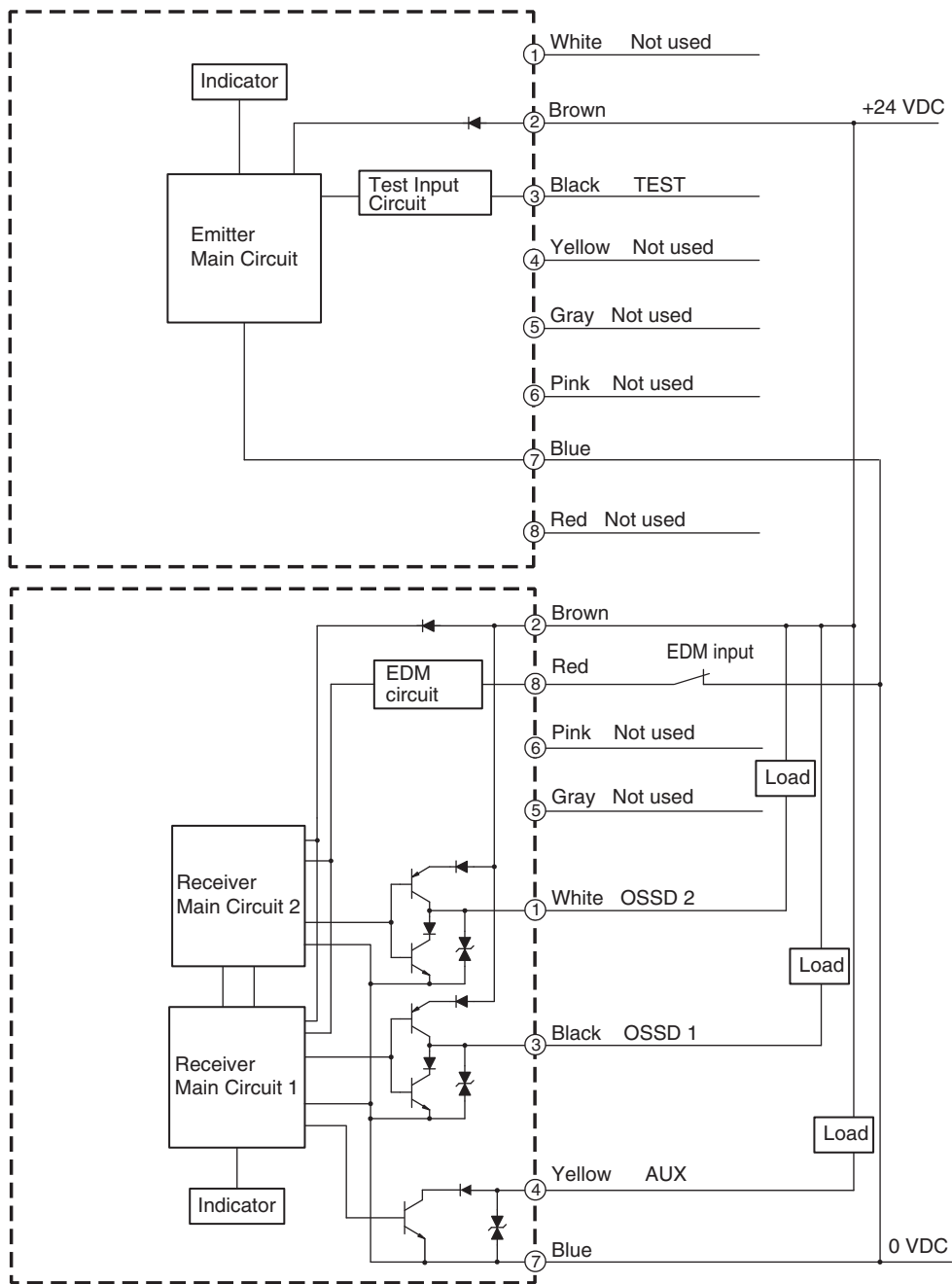

**Input Circuit Diagram by Function**

The input circuit diagrams of by function are shown below.

**TEST**

<24 V Inactive>

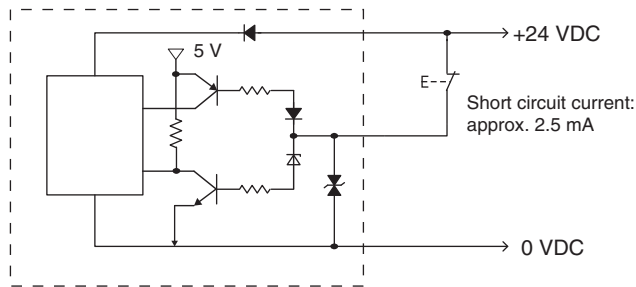

<0 V Inactive>

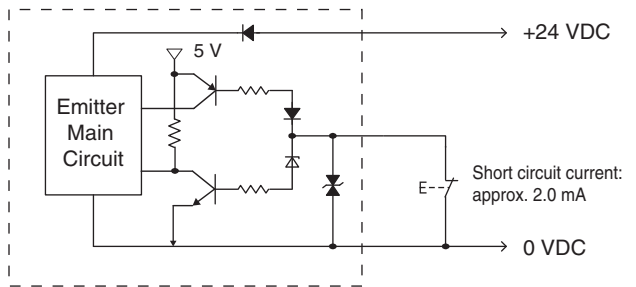

**EDM**

<PNP Output>

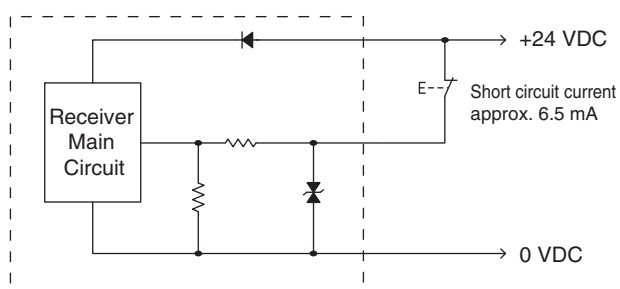

<NPN Output>

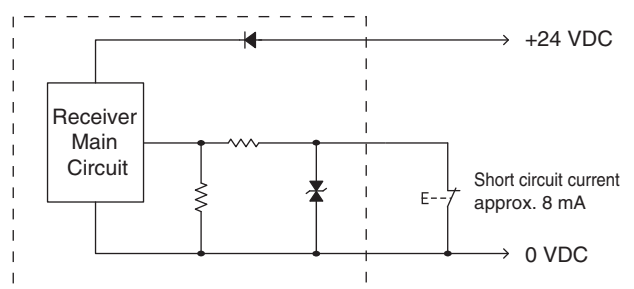

### Mounted with Standard Fixed Brackets (F39-LGF)

#### Backside Mounting

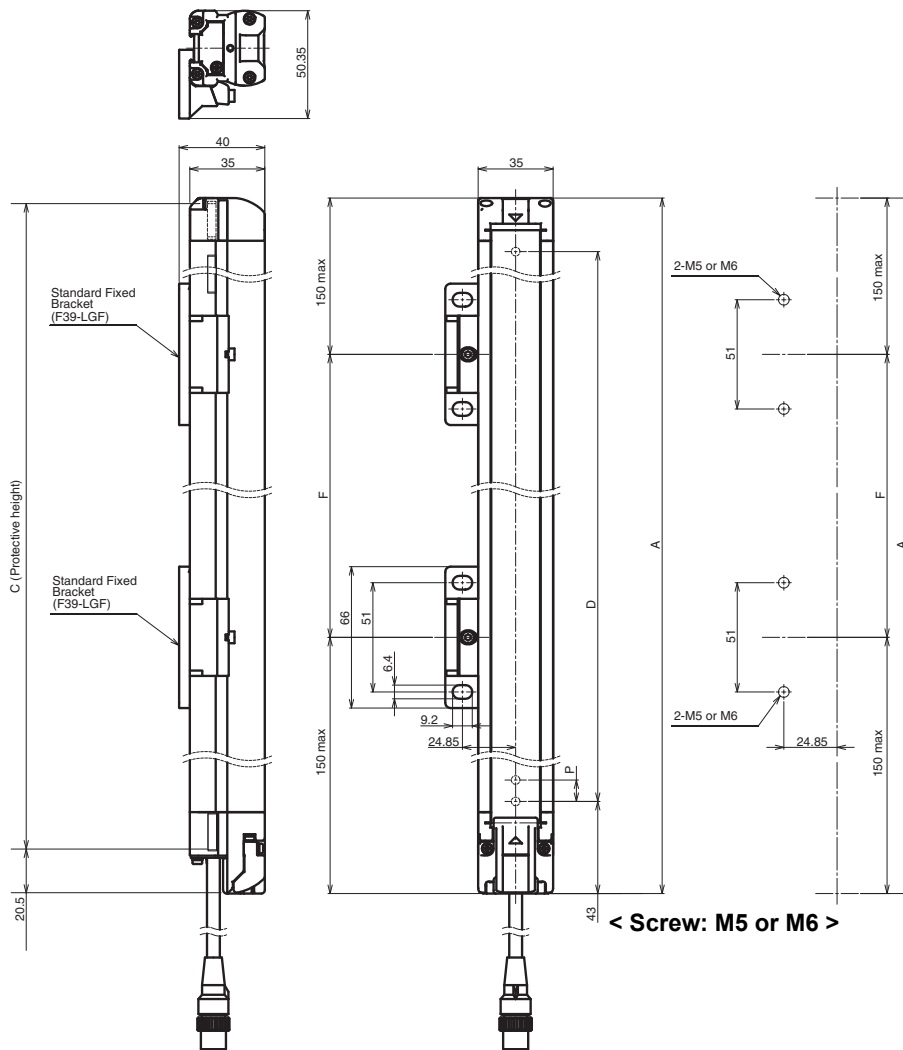

#### F3SG-4RA□□□□-25-01TS Series

Dimension A	C+23
Dimension C	4-digit number of the type name (Protective height)
Dimension D	C-45
Dimension P	20

Protective height (C1)	Number of Standard Fixed Brackets *1	Dimension F
0185 to 1225	2 *2	1000 mm max.
1305 to 1945	3	1000 mm max.

\*1. The number of brackets required to mount either one of emitter and receiver.

\*2. Mounting an emitter or receiver with one bracket is possible for the models of protective height of 0185 or 0265. In this case, locate this bracket at half the Dimension A (or at the center of the sensor length).

Side Mounting

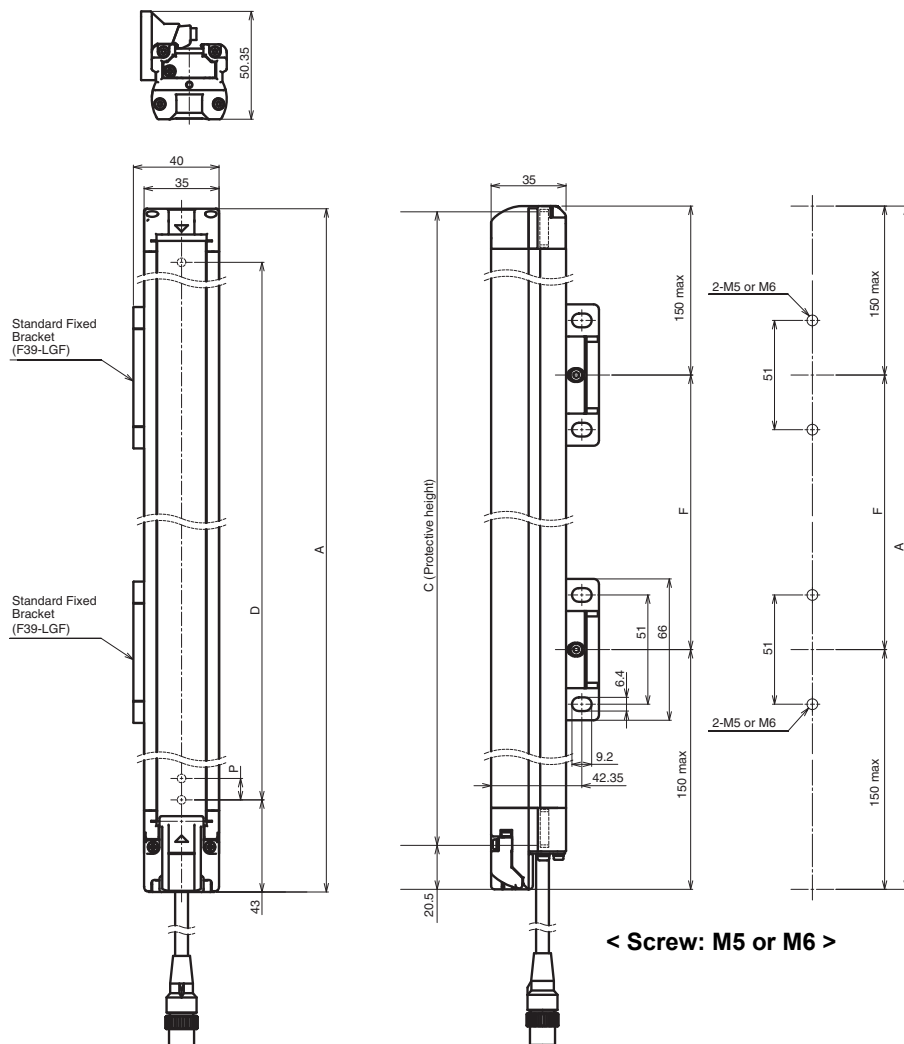

F3SG-4RA□□□□-25-01TS Series

Dimension A	C+23
Dimension C	4-digit number of the type name (Protective height)
Dimension D	C-45
Dimension P	20

Protective height (C1)	Number of Standard Fixed Brackets *1	Dimension F
0185 to 1225	2 *2	1000 mm max.
1305 to 1945	3	1000 mm max.

\*1. The number of brackets required to mount either one of emitter and receiver.

\*2. Mounting an emitter or receiver with one bracket is possible for the models of protective height of 0185 or 0265. In this case, locate this bracket at half the Dimension A (or at the center of the sensor length).

F3SG-RA-01TS

## Mounted with Standard Adjustable Brackets (F39-LGA) Backside Mounting

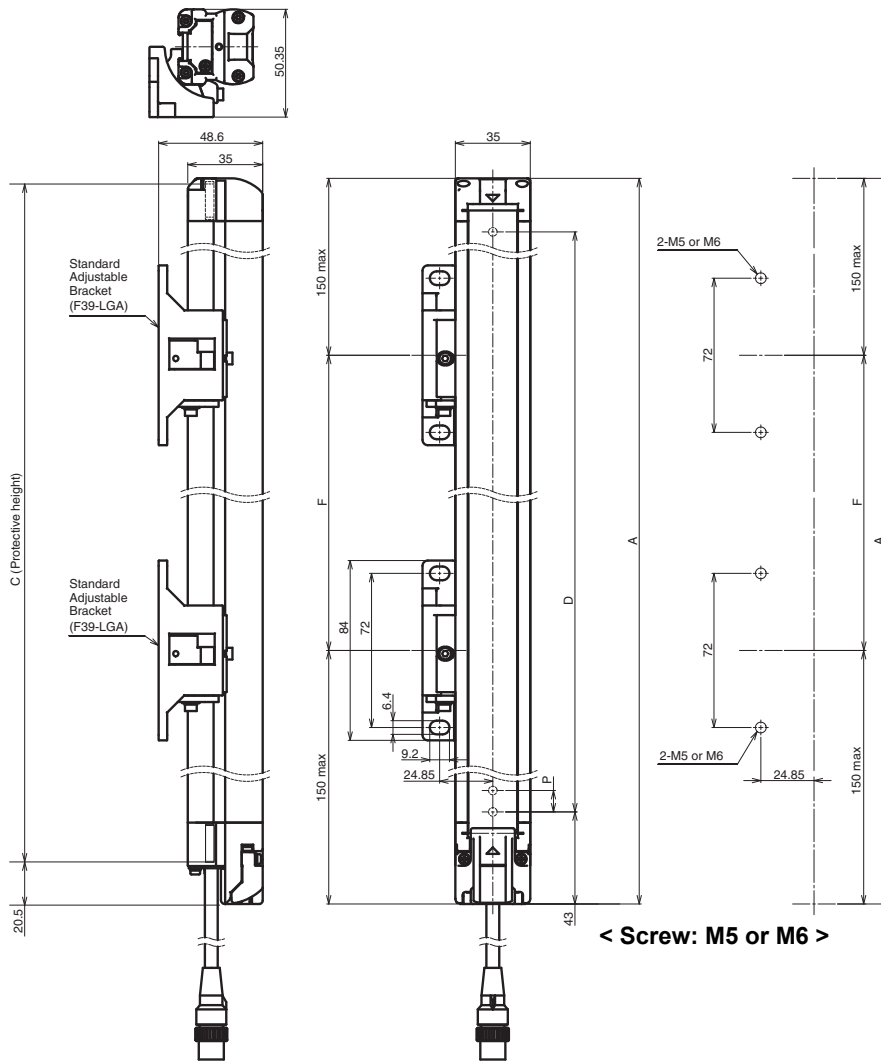

### F3SG-4RA□□□□-25-01TS Series

<b>Dimension A</b>	C+23
<b>Dimension C</b>	4-digit number of the type name (Protective height)
<b>Dimension D</b>	C-45
<b>Dimension P</b>	20

Protective height (C)	Number of Standard Adjustable Brackets *1	Dimension F
0185 to 1225	2 *2	1000 mm max.
1305 to 1945	3	1000 mm max.

\*1. The number of brackets required to mount either one of emitter and receiver.

\*2. Mounting an emitter or receiver with one bracket is possible for the models of protective height of 0185 or 0265. In this case, locate this bracket at half the Dimension A (or at the center of the sensor length).



# F3SG-RA-01TS

## Mounted with Top/Bottom Adjustable Brackets (F39-LGTB) and Standard Adjustable Brackets (F39-LGA)

Dimensions when using the F3SG-RA Series except the F3SG-4RA0185-25-01TS.

Refer to *Safety Light Curtain F3SG-4RA□□□□-25-01TS Series User's Manual* for the dimensions when using the F3SG-4RA0185-25-01TS.

### Backside Mounting

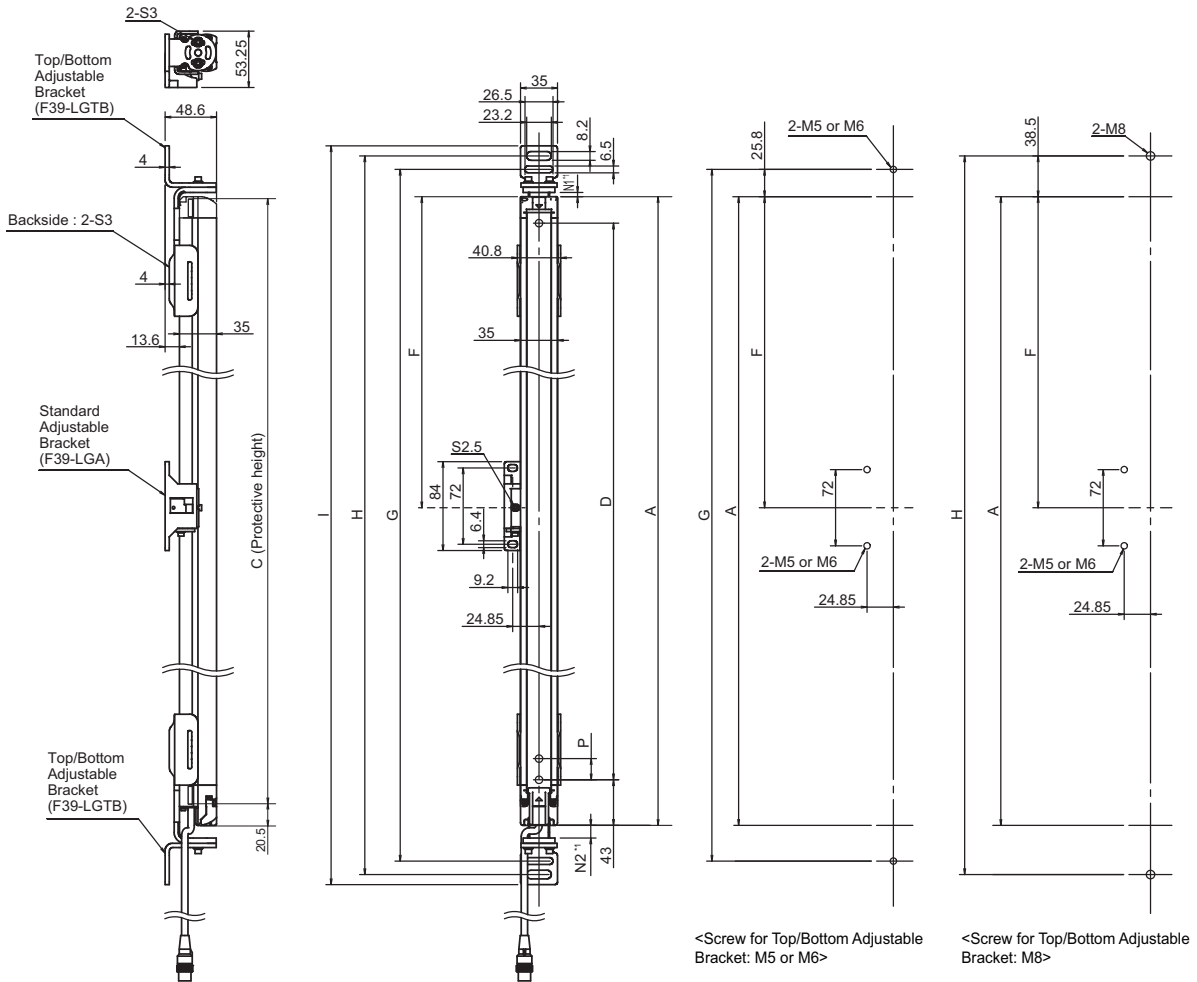

<Screw for Top/Bottom Adjustable Bracket: M5 or M6>

<Screw for Top/Bottom Adjustable Bracket: M8>

### F3SG-4RA□□□□-25-01TS Series (Except for 0185)

	Optional accessory not connected	Optional accessory connected *2		
		F39-JGR2WTS	F39-BT	F39-LP F39-BTLP
Dimension A	C+23	Same as on the left		
Dimension C	4-digit number of the type name (Protective height)	Same as on the left		
Dimension D	C-45	Same as on the left		
Dimension G	C+N1+N2+66.5	C+N2+73.5	C+N2+84	C+N2+95.5
Dimension H	C+N1+N2+92.0	C+N2+99	C+N2+109.5	C+N2+121
Dimension I	C+N1+N2+111.0	C+N2+118	C+N2+128.5	C+N2+140
Dimension P	20	Same as on the left		

\*1.N1 can be adjusted from 0 mm to 30 mm and N2 from 0 mm to 12 mm.

\*2.Refer to *Safety Light Curtain F3SG-4RA□□□□-25-01TS Series User's Manual* for more information on the dimensions when optional accessories are connected to the F3SG-RA.

Protective height (C)	Number of Standard Adjustable Brackets	Number of Standard Adjustable Brackets *1 *2	Dimension F
0265 to 1065	2	0	-
1145 to 1945	2	1	1000 mm max.

\*1.The number of brackets required to mount either one of emitter and receiver.

\*2.The Top/Bottom Adjustable Bracket is not useable together with the Standard Fixed Bracket. When it is necessary to use it with another bracket, only the combination with the Standard Adjustable Bracket is possible.

Side Mounting

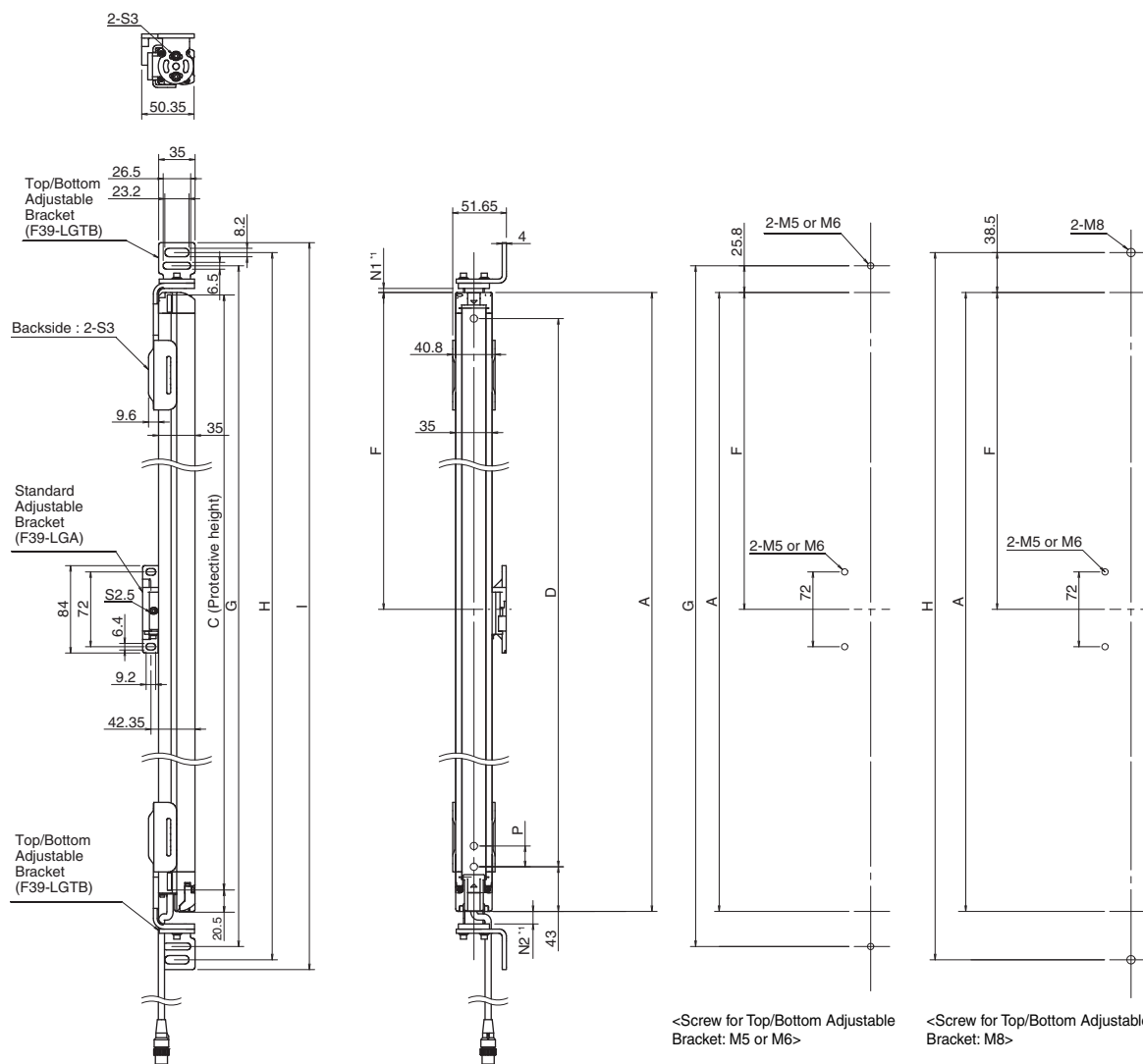

F3SG-4RA□□□□-25-01TS Series (Except for 0185)

	Optional accessory not connected	Optional accessory connected *2		
		F39-JGR2WTS	F39-BT	F39-LP F39-BTLP
Dimension A	C+23	Same as on the left		
Dimension C	4-digit number of the type name (Protective height)	Same as on the left		
Dimension D	C-45	Same as on the left		
Dimension G	C+N1+N2+66.5	C+N2+73.5	C+N2+84	C+N2+95.5
Dimension H	C+N1+N2+92.0	C+N2+99	C+N2+109.5	C+N2+121
Dimension I	C+N1+N2+111.0	C+N2+118	C+N2+128.5	C+N2+140
Dimension P	20	Same as on the left		

\*1.N1 can be adjusted from 0 mm to 30 mm and N2 from 0 mm to 12 mm.

\*2.Refer to *Safety Light Curtain F3SG-4RA□□□□-25-01TS Series User's Manual* for more information on the dimensions when optional accessories are connected to the F3SG-RA.

Protective height (C)	Number of Standard Adjustable Brackets	Number of Standard Adjustable Brackets *1 *2	Dimension F
0265 to 1065	2	0	-
1145 to 1945	2	1	1000 mm max.

\*1.The number of brackets required to mount either one of emitter and receiver.

\*2.The Top/Bottom Adjustable Bracket is not useable together with the Standard Fixed Bracket. When it is necessary to use it with another bracket, only the combination with the Standard Adjustable Bracket is possible.

F3SG-RA-01TS

## Accessories

### Sensor Mounting Brackets

#### Standard Fixed Bracket (F39-LGF)

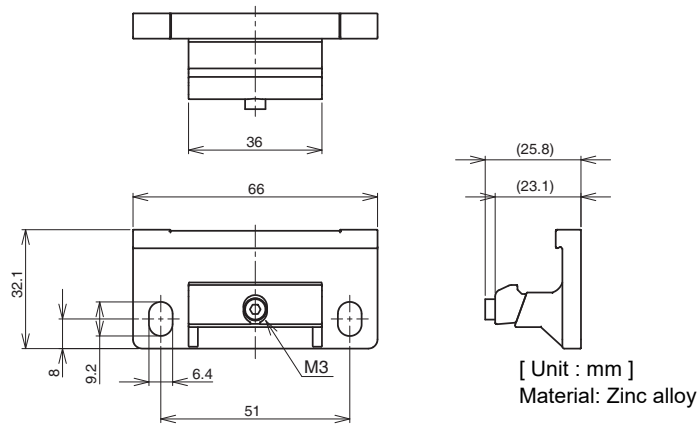

#### Standard Adjustable Bracket (F39-LGA, sold separately)

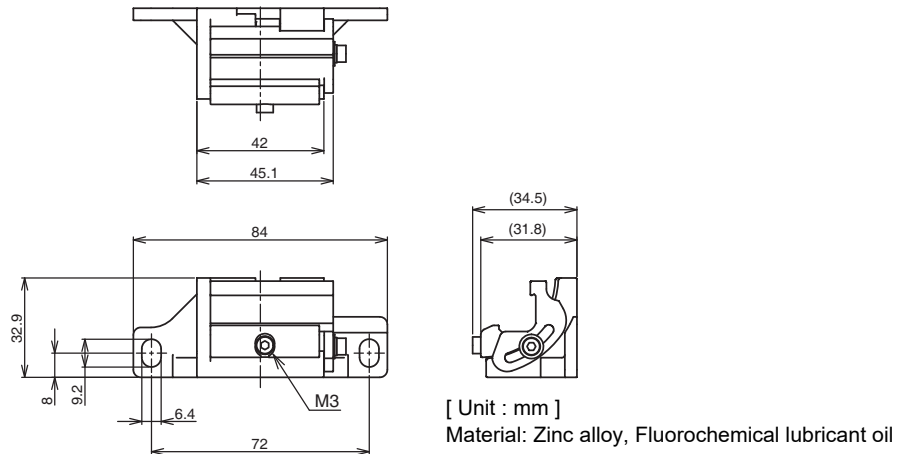

#### Top/Bottom Adjustable Bracket (F39-LGTB, sold separately)

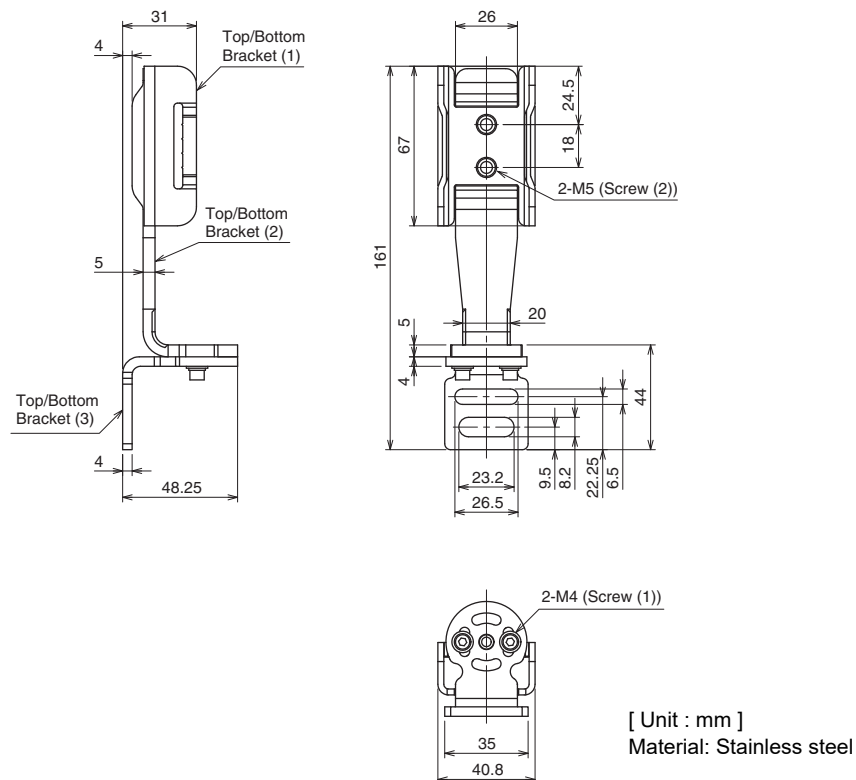

Safety light curtain connecting cable

Single-Ended Cable for Emitter (F39-JD□A-L, sold separately)

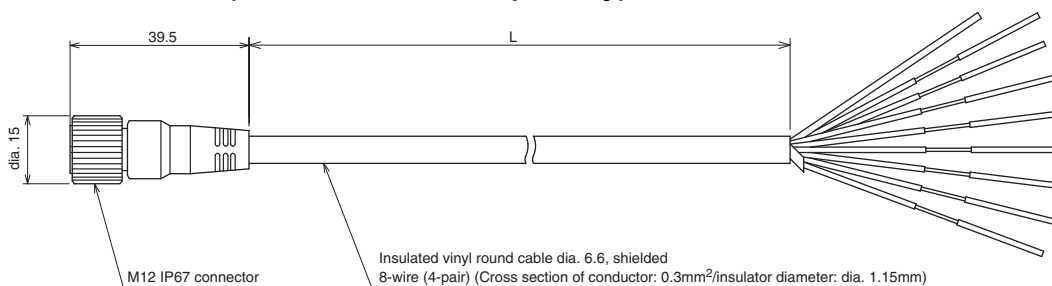

Single-Ended Cable for Receiver (F39-JD□A-D, sold separately)

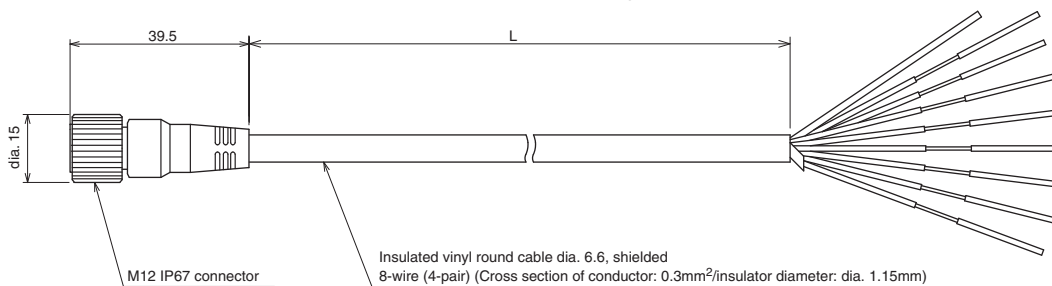

Emitter cable (Gray)	Receiver cable (Black)	L (m)
F39-JD3A-L	F39-JD3A-D	3
F39-JD7A-L	F39-JD7A-D	7
F39-JD10A-L	F39-JD10A-D	10
F39-JD15A-L	F39-JD15A-D	15
F39-JD20A-L	F39-JD20A-D	20

Double-Ended Cable for Emitter: Cable for extension (F39-JD□B-L, sold separately)

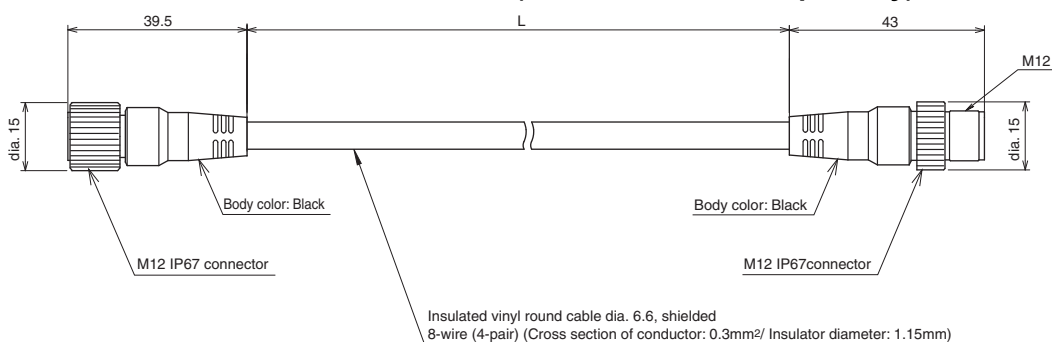

Double-Ended Cable for Receiver: Cable for extension (F39-JD□B-D, sold separately)

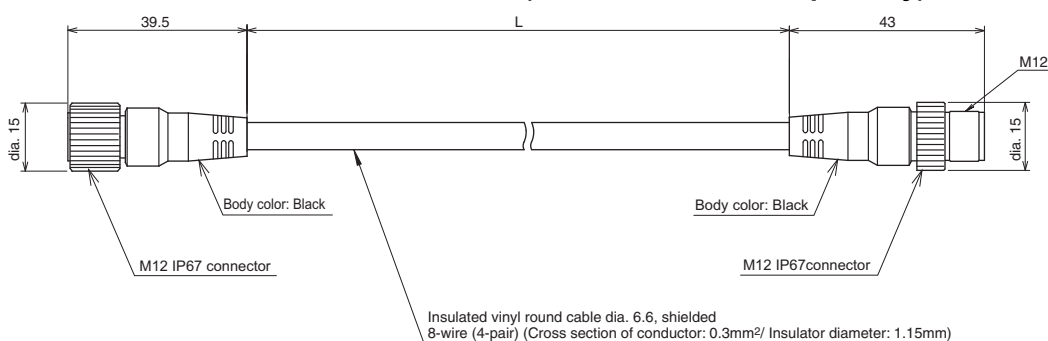

Emitter cable (Gray)	Receiver cable (Black)	L (m)
F39-JDR5B-L	F39-JDR5B-D	0.5
F39-JD1B-L	F39-JD1B-D	1
F39-JD3B-L	F39-JD3B-D	3
F39-JD5B-L	F39-JD5B-D	5
F39-JD7B-L	F39-JD7B-D	7
F39-JD10B-L	F39-JD10B-D	10
F39-JD15B-L	F39-JD15B-D	15
F39-JD20B-L	F39-JD20B-D	20

F3SG-RA-01TS

# F3SG-RA-01TS

## Reduced Wiring Connector (F39-CN5, sold separately)

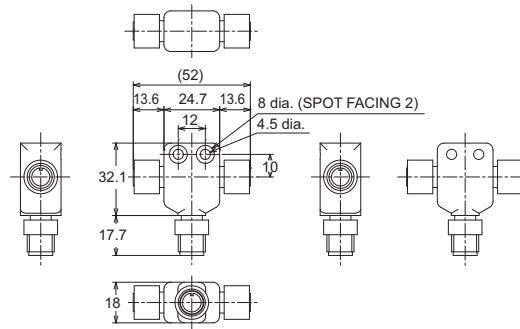

## Cascading Cable for Emitter (F39-JGR2WTS-L, sold separately)

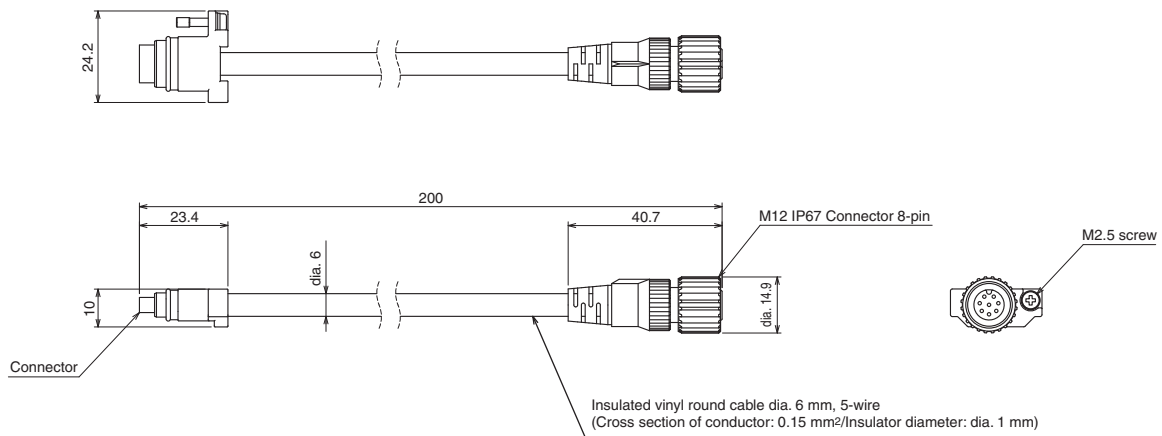

## Cascading Cable for Receiver (F39-JGR2WTS-D, sold separately)

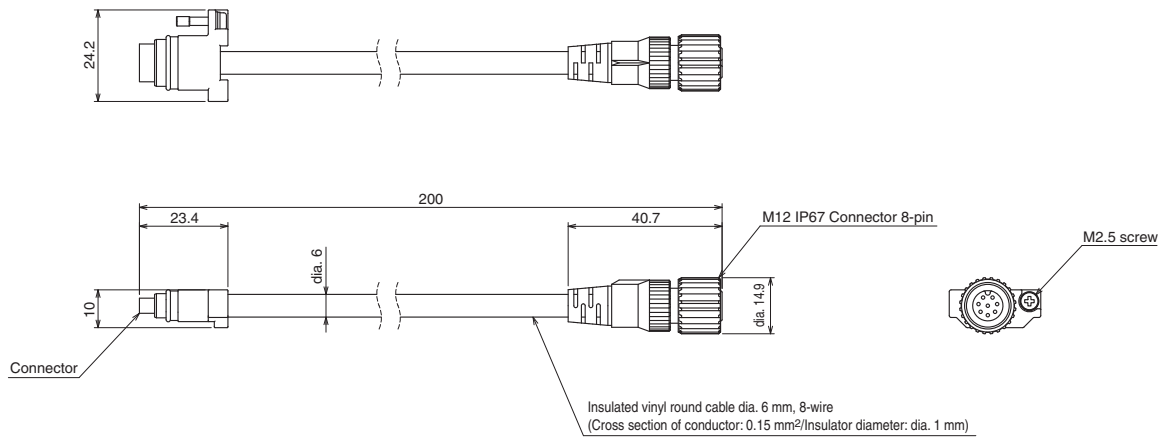

Set model name	Emitter cable (Gray)	Receiver cable (Black)	L (m)
F39-JGR2WTS	F39-JGR2WTS-L	F39-JGR2WTS-D	0.2

**Interface Unit (F39-GIF, sold separately)**

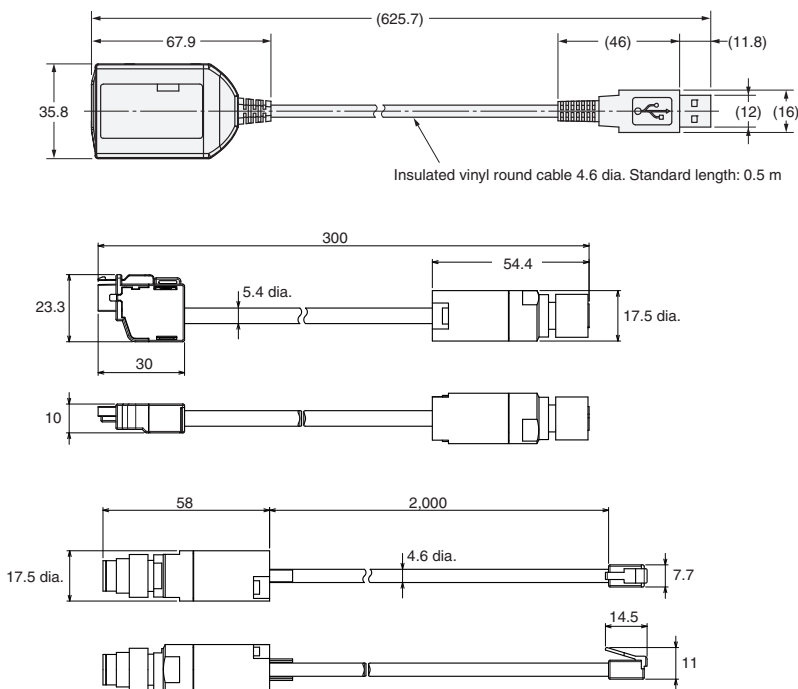

**Spatter Protection Cover (F39-HGA, sold separately)**

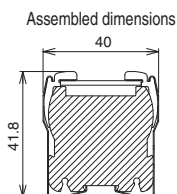

Model	Total length
F39-HGA□□□□	□□□□+4
F39-HGA0550	558

Material: PC (Transparent cover)  
 ABS (Side wall)  
 Stainless steel (Bracket)  
 Aluminum adhesive tape  
 (Fixing sticker)

**Bluetooth Communication Unit (F39-BT, sold separately)**

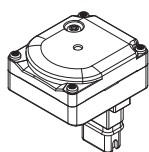

Material: PBT

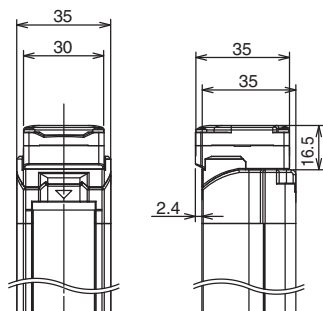

**Lamp and Bluetooth Communication Unit (F39-BTLP, sold separately)  
 Lamp (F39-LP, sold separately)**

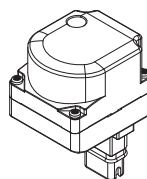

Material:  
 PC (Lighting element)  
 PBT (Other body parts)

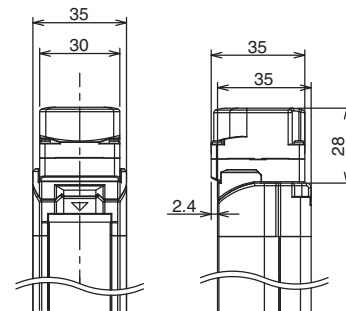

**Related Manuals**

ManNo.	Model	Manual name
Z380	F3SG-4RA□□□□-25-01TS	Safety Light Curtain F3SG-4RA□□□□-25-01TS Series User's Manual

F3SG-RA-01TS

# Safety Light Curtain

# F3SG-RA-02TS

## Enhanced Cutting Oil Resistance

- Mechanical seal structure prevents cutting oil from getting inside
- Special materials and cables significantly enhanced oil resistance
- Rugged and compact housing. Perfect fit installation
- IP67G (JIS C 0920 Annex 1) rated
- Prevents accidental changes of settings by configuration tool (monitoring only)



## System Configuration

### Mounting bracket



### Accessory \*1

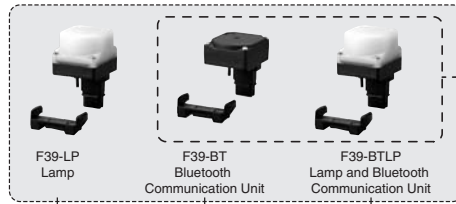

### Accessory

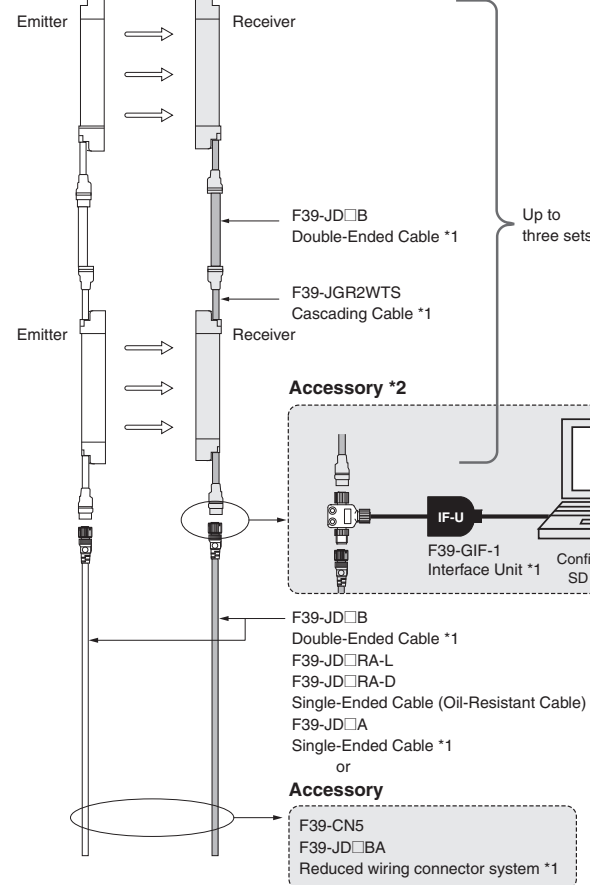

### Recommended safety controller \*3

NX/NE1A-series  
Safety Network Controller

G9SP-series  
Safety Controller

G9SE/G9SA-series  
Safety Relay Unit

G9SX-series  
Flexible Safety Unit

G7SA/G7S-E  
Relays with Forcibly  
Guided Contacts

- \*1. When the accessory is used, protect it from cutting oil.  
 \*2. The F3SG-RA-02TS provides only the monitoring functionality.  
 \*3. The recommended safety controller is required to build a safety circuit using emergency stop switches and door switches.

## Ordering Information

### Main Units

Safety Light Curtain

Hand and arm protection

Number of beams	Protective height (mm)	Model
12	240	F3SG-4RA0240-25-02TS
16	320	F3SG-4RA0320-25-02TS
20	400	F3SG-4RA0400-25-02TS
24	480	F3SG-4RA0480-25-02TS
28	560	F3SG-4RA0560-25-02TS
32	640	F3SG-4RA0640-25-02TS
36	720	F3SG-4RA0720-25-02TS
40	800	F3SG-4RA0800-25-02TS
44	880	F3SG-4RA0880-25-02TS
48	960	F3SG-4RA0960-25-02TS
52	1,040	F3SG-4RA1040-25-02TS
56	1,120	F3SG-4RA1120-25-02TS
60	1,200	F3SG-4RA1200-25-02TS
64	1,280	F3SG-4RA1280-25-02TS
68	1,360	F3SG-4RA1360-25-02TS
72	1,440	F3SG-4RA1440-25-02TS
76	1,520	F3SG-4RA1520-25-02TS
80	1,600	F3SG-4RA1600-25-02TS
84	1,680	F3SG-4RA1680-25-02TS
88	1,760	F3SG-4RA1760-25-02TS
92	1,840	F3SG-4RA1840-25-02TS
96	1,920	F3SG-4RA1920-25-02TS

# F3SG-RA-02TS



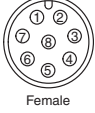
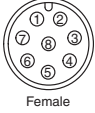
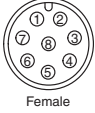

## Accessories (Sold separately)

### Safety light curtain connecting cable Single-Ended Cable (Oil-Resistant Cable)

Appearance	Type	Cable length	Specifications	Model																								
	For emitter M12 connector (8-pin), 5 wires Color: Gray	3m	For emitter, M12 connector (8-pin), Color: Gray Connected to Power Cable or Double-Ended Cable  <table border="1"> <tr><td>1</td><td>-</td><td>Not used</td></tr> <tr><td>2</td><td>Brown</td><td>+24 VDC</td></tr> <tr><td>3</td><td>Black</td><td>TEST</td></tr> <tr><td>4</td><td>-</td><td>Not used</td></tr> <tr><td>5</td><td>Gray</td><td>Not used</td></tr> <tr><td>6</td><td>Pink</td><td>Not used</td></tr> <tr><td>7</td><td>Blue</td><td>0 VDC</td></tr> <tr><td>8</td><td>-</td><td>Not used</td></tr> </table>	1	-	Not used	2	Brown	+24 VDC	3	Black	TEST	4	-	Not used	5	Gray	Not used	6	Pink	Not used	7	Blue	0 VDC	8	-	Not used	F39-JD3RA-L
		1	-	Not used																								
	2	Brown	+24 VDC																									
	3	Black	TEST																									
4	-	Not used																										
5	Gray	Not used																										
6	Pink	Not used																										
7	Blue	0 VDC																										
8	-	Not used																										
7m	For receiver, M12 connector (8-pin), Color: Black Connected to Power Cable or Double-Ended Cable  <table border="1"> <tr><td>1</td><td>White</td><td>OSSD 2</td></tr> <tr><td>2</td><td>Brown</td><td>+24 VDC</td></tr> <tr><td>3</td><td>Black</td><td>OSSD 1</td></tr> <tr><td>4</td><td>Yellow</td><td>AUX</td></tr> <tr><td>5</td><td>Gray</td><td>PC COM (+)</td></tr> <tr><td>6</td><td>Pink</td><td>PC COM (-)</td></tr> <tr><td>7</td><td>Blue</td><td>0 VDC</td></tr> <tr><td>8</td><td>Red</td><td>EDM</td></tr> </table>	1	White	OSSD 2	2	Brown	+24 VDC	3	Black	OSSD 1	4	Yellow	AUX	5	Gray	PC COM (+)	6	Pink	PC COM (-)	7	Blue	0 VDC	8	Red	EDM	F39-JD7RA-L		
1	White	OSSD 2																										
2	Brown	+24 VDC																										
3	Black	OSSD 1																										
4	Yellow	AUX																										
5	Gray	PC COM (+)																										
6	Pink	PC COM (-)																										
7	Blue	0 VDC																										
8	Red	EDM																										
For receiver M12 connector (8-pin), 8 wires Color: Black	3m	For receiver, M12 connector (8-pin), Color: Black Connected to Power Cable or Double-Ended Cable  <table border="1"> <tr><td>1</td><td>White</td><td>OSSD 2</td></tr> <tr><td>2</td><td>Brown</td><td>+24 VDC</td></tr> <tr><td>3</td><td>Black</td><td>OSSD 1</td></tr> <tr><td>4</td><td>Yellow</td><td>AUX</td></tr> <tr><td>5</td><td>Gray</td><td>PC COM (+)</td></tr> <tr><td>6</td><td>Pink</td><td>PC COM (-)</td></tr> <tr><td>7</td><td>Blue</td><td>0 VDC</td></tr> <tr><td>8</td><td>Red</td><td>EDM</td></tr> </table>	1	White	OSSD 2	2	Brown	+24 VDC	3	Black	OSSD 1	4	Yellow	AUX	5	Gray	PC COM (+)	6	Pink	PC COM (-)	7	Blue	0 VDC	8	Red	EDM	F39-JD3RA-D	
	1	White	OSSD 2																									
2	Brown	+24 VDC																										
3	Black	OSSD 1																										
4	Yellow	AUX																										
5	Gray	PC COM (+)																										
6	Pink	PC COM (-)																										
7	Blue	0 VDC																										
8	Red	EDM																										
7m	IP67 and IP67G (JIS C 0920 Annex 1)* rated when mated. * F3SG-RA-02TS meets the degree of protection when this cable is correctly connected with the power cable of the F3SG-RA-02TS. The degree of protection is not satisfied with the part where cable wires are uncovered.	F39-JD7RA-D																										

**Note:** To extend the cable length to more than 7 m, add the F39-JD□B Double-Ended Cable.  
When the Double-Ended Cable is used, protect it from cutting oil.

### Single-Ended Cable (2 cables per set, one for emitter and one for receiver) \*

Appearance	Cable length	Specifications	Model																								
	3m	For emitter M12 connector (8-pin), Color: Gray Connected to Power Cable or Double-Ended Cable  <table border="1"> <tr><td>1</td><td>White</td><td>Not used</td></tr> <tr><td>2</td><td>Brown</td><td>+24 VDC</td></tr> <tr><td>3</td><td>Black</td><td>TEST</td></tr> <tr><td>4</td><td>Yellow</td><td>Not used</td></tr> <tr><td>5</td><td>Gray</td><td>Not used</td></tr> <tr><td>6</td><td>Pink</td><td>Not used</td></tr> <tr><td>7</td><td>Blue</td><td>0 VDC</td></tr> <tr><td>8</td><td>Red</td><td>Not used</td></tr> </table>	1	White	Not used	2	Brown	+24 VDC	3	Black	TEST	4	Yellow	Not used	5	Gray	Not used	6	Pink	Not used	7	Blue	0 VDC	8	Red	Not used	F39-JD3A
	1	White	Not used																								
	2	Brown	+24 VDC																								
	3	Black	TEST																								
	4	Yellow	Not used																								
5	Gray	Not used																									
6	Pink	Not used																									
7	Blue	0 VDC																									
8	Red	Not used																									
7m	For receiver M12 connector (8-pin), Color: Black Connected to Power Cable or Double-Ended Cable  <table border="1"> <tr><td>1</td><td>White</td><td>OSSD 2</td></tr> <tr><td>2</td><td>Brown</td><td>+24 VDC</td></tr> <tr><td>3</td><td>Black</td><td>OSSD 1</td></tr> <tr><td>4</td><td>Yellow</td><td>AUX</td></tr> <tr><td>5</td><td>Gray</td><td>PC COM (+)</td></tr> <tr><td>6</td><td>Pink</td><td>PC COM (-)</td></tr> <tr><td>7</td><td>Blue</td><td>0 VDC</td></tr> <tr><td>8</td><td>Red</td><td>EDM</td></tr> </table>	1	White	OSSD 2	2	Brown	+24 VDC	3	Black	OSSD 1	4	Yellow	AUX	5	Gray	PC COM (+)	6	Pink	PC COM (-)	7	Blue	0 VDC	8	Red	EDM	F39-JD7A	
1	White	OSSD 2																									
2	Brown	+24 VDC																									
3	Black	OSSD 1																									
4	Yellow	AUX																									
5	Gray	PC COM (+)																									
6	Pink	PC COM (-)																									
7	Blue	0 VDC																									
8	Red	EDM																									
10m	For receiver M12 connector (8-pin), Color: Black Connected to Power Cable or Double-Ended Cable  <table border="1"> <tr><td>1</td><td>White</td><td>OSSD 2</td></tr> <tr><td>2</td><td>Brown</td><td>+24 VDC</td></tr> <tr><td>3</td><td>Black</td><td>OSSD 1</td></tr> <tr><td>4</td><td>Yellow</td><td>AUX</td></tr> <tr><td>5</td><td>Gray</td><td>PC COM (+)</td></tr> <tr><td>6</td><td>Pink</td><td>PC COM (-)</td></tr> <tr><td>7</td><td>Blue</td><td>0 VDC</td></tr> <tr><td>8</td><td>Red</td><td>EDM</td></tr> </table>	1	White	OSSD 2	2	Brown	+24 VDC	3	Black	OSSD 1	4	Yellow	AUX	5	Gray	PC COM (+)	6	Pink	PC COM (-)	7	Blue	0 VDC	8	Red	EDM	F39-JD10A	
1	White	OSSD 2																									
2	Brown	+24 VDC																									
3	Black	OSSD 1																									
4	Yellow	AUX																									
5	Gray	PC COM (+)																									
6	Pink	PC COM (-)																									
7	Blue	0 VDC																									
8	Red	EDM																									
15m	For receiver M12 connector (8-pin), Color: Black Connected to Power Cable or Double-Ended Cable  <table border="1"> <tr><td>1</td><td>White</td><td>OSSD 2</td></tr> <tr><td>2</td><td>Brown</td><td>+24 VDC</td></tr> <tr><td>3</td><td>Black</td><td>OSSD 1</td></tr> <tr><td>4</td><td>Yellow</td><td>AUX</td></tr> <tr><td>5</td><td>Gray</td><td>PC COM (+)</td></tr> <tr><td>6</td><td>Pink</td><td>PC COM (-)</td></tr> <tr><td>7</td><td>Blue</td><td>0 VDC</td></tr> <tr><td>8</td><td>Red</td><td>EDM</td></tr> </table>	1	White	OSSD 2	2	Brown	+24 VDC	3	Black	OSSD 1	4	Yellow	AUX	5	Gray	PC COM (+)	6	Pink	PC COM (-)	7	Blue	0 VDC	8	Red	EDM	F39-JD15A	
1	White	OSSD 2																									
2	Brown	+24 VDC																									
3	Black	OSSD 1																									
4	Yellow	AUX																									
5	Gray	PC COM (+)																									
6	Pink	PC COM (-)																									
7	Blue	0 VDC																									
8	Red	EDM																									
20m	IP67* rated when mated. * When the accessory is used, protect it from cutting oil.	F39-JD20A																									

\* The cable for emitter and the cable for receiver are available separately. Add '-L' for emitter or '-D' for receiver to the end of the model number when you order.

Single-Ended Cable for Emitter: F39-JD□A-L, Single-Ended Cable for Receiver: F39-JD□A-D

**Note:** 1. Use the F39-JD□RA-L/-D for applications where cutting oil resistance is required.  
2. To extend the cable length to more than 20 m, add the F39-JD□B Double-Ended Cable.

**Double-Ended Cable (2 cables per set, one for emitter and one for receiver) \***

Appearance	Cable length	Specifications	Model
	0.5m	For emitter M12 connector (8-pin), Color: Gray Connected to Power Cable or Double-Ended Cable	F39-JDR5B
	1m	Connected to Single-Ended Cable, or Double-Ended Cable	F39-JD1B
	3m		F39-JD3B
	5m		F39-JD5B
	7m		F39-JD7B
	10m		F39-JD10B
	15m		F39-JD15B
	20m		F39-JD20B
			For receiver, M12 connector(8-pin) Color: Black Connected to Power Cable or Double-Ended Cable

\* The cable for emitter and the cable for receiver are available separately. Add '-L' for emitter or '-D' for receiver to the end of the model number when you order.

Double-Ended Cable for Emitter: F39-JD□B-L, Double-Ended Cable for Receiver: F39-JD□B-D

**Note:** To extend the cable length to more than 20 m, add the F39-JD□B Double-Ended Cable to the F39-JD□A Single-Ended Cable.

To extend the cable length to more than 40 m, add several Double-Ended Cables to the Single-Ended Cable.

Example: To extend the cable length to 50 m, connect two F39-JD20B (20 m) cables and one F39-JD10A (10 m) cable.

**<Connection example>**

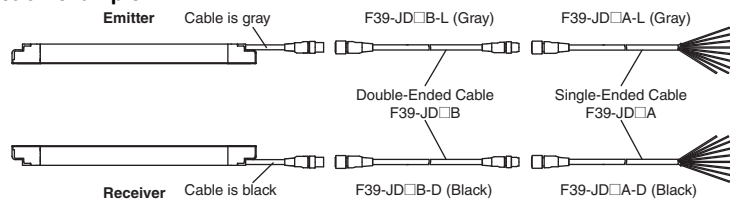

**Reduced Wiring Connector System (Order the F39-CN5 and Cables for Reduce Wiring.)**

Appearance	Specifications	Model
	IP67* rated when mated. * When the accessory is used, protect it from cutting oil.	F39-CN5

**Note:** When using the Reduced Wiring Connector (F39-CN5), the following functions are not available.

- External Device Monitoring
- Auxiliary Output

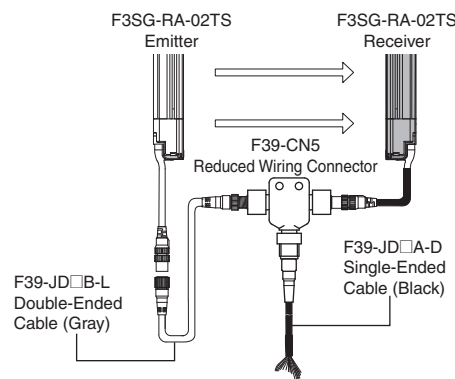

**Cable for Reduce Wiring\* (2 cables per set, one for emitter and one for receiver)**

Appearance	Cable length	Specifications	Remarks	Model
	Emitter: 3 m Receiver: 3 m	IP67* rated when mated. * When the accessory is used, protect it from cutting oil.	Double-Ended Cable: F39-JD3B-L Single-Ended Cable: F39-JD3A-D	F39-JD0303BA
	Emitter: 3 m Receiver: 7 m		Double-Ended Cable: F39-JD3B-L Single-Ended Cable: F39-JD7A-D	F39-JD0307BA
	Emitter: 3 m Receiver: 10 m		Double-Ended Cable: F39-JD3B-L Single-Ended Cable: F39-JD10A-D	F39-JD0310BA
	Emitter: 5 m Receiver: 3 m		Double-Ended Cable: F39-JD5B-L Single-Ended Cable: F39-JD3A-D	F39-JD0503BA
	Emitter: 5 m Receiver: 7 m		Double-Ended Cable: F39-JD5B-L Single-Ended Cable: F39-JD7A-D	F39-JD0507BA
	Emitter: 5 m Receiver: 10m		Double-Ended Cable: F39-JD5B-L Single-Ended Cable: F39-JD10A-D	F39-JD0510BA
	Emitter: 10 m Receiver: 3 m		Double-Ended Cable: F39-JD10B-L Single-Ended Cable: F39-JD3A-D	F39-JD1003BA
	Emitter: 10 m Receiver: 7 m		Double-Ended Cable: F39-JD10B-L Single-Ended Cable: F39-JD7A-D	F39-JD1007BA
	Emitter: 10 m Receiver: 10 m		Double-Ended Cable: F39-JD10B-L Single-Ended Cable: F39-JD10A-D	F39-JD1010BA

**Note:** A combination of emitter and receiver cables of other lengths than the above is also available. For details, contact your Omron representative.

\* Double-Ended Cable for emitter and Single-Ended Cable for receiver.

F3SG-RA-02TS

# F3SG-RA-02TS



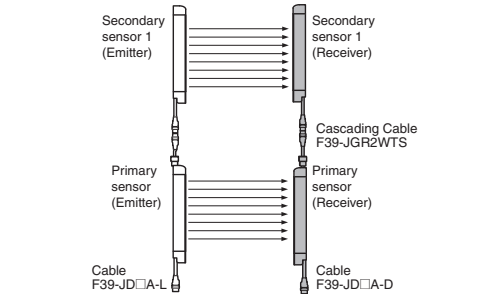

## Cascading Cable (2 cables per set, one for emitter and one for receiver)

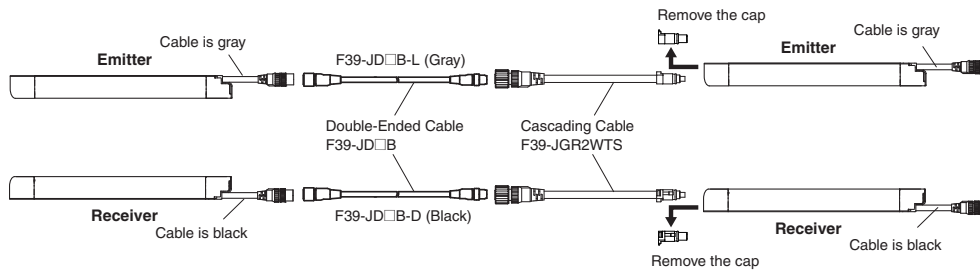
Appearance	Type	Cable length	Specifications	Model
	Cap (8-pin), M12 connector (8-pin)	0.2m	 <p>IP67* rated when mated. * When the accessory is used, protect it from cutting oil.</p>	<b>F39-JGR2WTS</b>

**Note:** The Double-Ended Cable (up to 10 m: F39-JD10B) can be added to extend the cable length between the series-connected sensors. Cable length between sensors: 10 m max. (not including cascading cable (F39-JGR2WTS) and power cable)



## Sensor Mounting Brackets



Appearance	Specifications	Application	Model
	Free-Location Bracket (Intermediate Bracket)	Beam alignment after mounting possible. The angle adjustment range is $\pm 15^\circ$ . Side mounting and backside mounting possible. (Sold separately as a set of 2 brackets. Refer to note *1 for the number of sets required for each model.)	<b>F39-LGRA</b>
	Top/Bottom Bracket *2	Use this bracket at the top and bottom positions of the F3SG-RA-02TS. Beam alignment after mounting possible. The angle adjustment range is $\pm 22.5^\circ$ . Side mounting and backside mounting possible. (Sold separately as a set of 4 brackets.)	<b>F39-LGRTB</b>
	Top/Bottom Bracket *2	The part of this bracket to contact with a wall surface has a different shape from the F39-LGRTB Top/Bottom Bracket. Use this bracket when replacing an existing safety light curtain with the F3SG-RA-02TS. (Sold separately as a set of 4 brackets.)	<b>F39-LGRTB-2</b>
	Top/Bottom Bracket *2	Select a bracket that fit into the existing mounting hole.	<b>F39-LGRTB-3</b>

\*1. Protective height of 0240 to 1200 mm: 2 sets, Protective height of 1280 to 1920 mm: 3 sets

\*2. Use the Top/Bottom Bracket in combination with the Intermediate Bracket.

Protective height of 1040 or less: The Intermediate Bracket is not required. Please purchase 1 set of Top/Bottom Brackets (F39-LGRTB(-2/-3)). Protective height of 1120 to 1920: Please purchase 1 set of Top/Bottom Brackets (F39-LGRTB(-2/-3)) and 1 set of Intermediate Brackets (F39-LGRA).

**Interface units and configuration tool SD Manager 2 \*1 \*2**

Appearance	Type	Specifications	Model
	SD Manager 2	The Configuration Tool SD Manager 2 is available to download from our website at <a href="http://www.ia.omron.com/f3sg-r_tool">http://www.ia.omron.com/f3sg-r_tool</a>	-
	Interface Unit	F39-GIF-1 interface unit to connect the F3SG-RA-02TS receiver to a USB port of the PC  Accessories: F39-CN1 Branch Connector (1), Connector Cap (1), 2-m Dedicated Cable (1), Instruction Manual	<b>F39-GIF-1</b>
	Bluetooth Communication Unit	F39-BT bluetooth unit to enable bluetooth on the F3SG-RA  IP67 rated when mated.	<b>F39-BT</b>

\*1. The F3SG-RA-02TS provides only the monitoring functionality.

\*2. When the accessory is used, protect it from cutting oil.

**Lamp \***

Appearance	Type	Specifications	Model
	Lamp	The lamp can be connected to a receiver and turned ON based on the operation of F3SG-RA. The lamp output pattern is set as follows: Red (ON): Inverted signal of safety output information Orange (Blink once): Inverted signal of stable-state information	<b>F39-LP</b>
	Lamp and Bluetooth Communication Unit	Green (ON): Safety output information  IP67 rated when mated.	<b>F39-BTLP</b>

\* When the accessory is used, protect it from cutting oil.

**End Cap \*1 \*2**

Appearance	Specifications	Model
	Housing color: Black For both emitter and receiver (Attached to the F3SG-RA-02TS. The End Cap can be purchased if lost.)  IP67 rated when mated.	<b>F39-CNM</b>

\*1. This accessory can also be used with the F3SG-RA-01TS.

\*2. When the accessory is used, protect it from cutting oil.

**Laser Pointer for F3SG-R \***

Appearance	Specifications	Model
	The laser pointer is attached on the optical surface of the F3SG-R to help coarse adjustment of beams.	<b>F39-PTG</b>

\* When the accessory is used, protect it from cutting oil.

**Test Rod**

Diameter	Model
25 mm dia.	<b>F39-TRD25</b>

# F3SG-RA-02TS

## Ratings and Specifications

### Main unit

The □□□□ in the model names indicate the protective heights in millimeters.

		F3SG-4RA□□□□-25-02TS		
Performance	Object Resolution (Detection Capability)	Opaque objects 25-mm dia.		
	Beam Gap	20 mm		
	Number of Beams	12 to 96		
	Lens Size	6.0 × 5.0 (W × H) mm		
	Protective Height	240 to 1920 mm		
	Operating Range	0.3 to 17.0 m		
	Response Time	ON to OFF	Normal mode: 8 to 13 ms *1	
		OFF to ON	Normal mode: 40 to 90ms (synchronized), 140 to 190ms (not synchronized) *1	
	*1. Response time when used in one segment system or in cascaded connection. Refer to page 128 for the one segment system. Refer to <i>Safety Light Curtain F3SG-4RA□□□□-25-02TS Series User's Manual (ManNo.: Z391)</i> for cascaded connection.			
	Effective Aperture Angle (EAA) (IEC 61496-2)	±2.5° max., emitter and receiver at operating range of 3 m or greater		
Light Source	Infrared LEDs, Wavelength: 870 nm			
Startup Waiting Time	2 s max.			
Electrical	Power Supply Voltage (Vs)	SELV/PELV 24 VDC±20% (ripple p-p 10% max.)		
	Current Consumption	Refer to page 128.		
	Safety Outputs (OSSD)	Two PNP transistor outputs Load current of 300 mA max., Residual voltage of 2 V max. (except for voltage drop due to cable extension), Capacitive load of 1 µF max., Inductive load of 2.2 H max. *1 Leakage current of 1 mA max.		
		*1. The load inductance is the maximum value when the safety output frequently repeats ON and OFF. When you use the safety output at 4 Hz or less, the usable load inductance becomes larger. *2. These values must be taken into consideration when connecting elements including a capacitive load such as a capacitor.		
	Auxiliary Output	One PNP transistor output Load current of 100 mA max., Residual voltage of 2 V max.		
	Output Operation Mode	Safety Output	Light-ON (Safety output is enabled when the receiver receives an emitting signal.)	
		Auxiliary Output	Reverse output of safety output	
	Input Voltage	External device monitoring input (Lockout reset input)	ON voltage: Vs-3 V to Vs (short circuit current: approx. 6.5 mA) * OFF voltage: 0 V to 1/2 Vs, or open (short circuit current: approx. 8.0 mA) *	
		Test input	24 V Active setting: ON voltage: 9 V to Vs (short circuit current: approx. 2.5 mA) * OFF voltage: 0 V to 3 V or open (short circuit current: approx. 2.0 mA) 0 V Active setting: ON voltage: 0 V to 3 V (short circuit current: approx. 2.0 mA) OFF voltage: 9 V to Vs or open (short circuit current: approx. 2.5 mA) *	
	* The Vs indicates a supply voltage value in your environment.			
Overvoltage Category (IEC 60664-1)	II			
Indicators	Refer to page 130.			
Protective Circuit	Output short protection, Power supply reverse polarity protection			
Insulation Resistance	20 MΩ or higher (500 VDC megger)			
Dielectric Strength	1,000 VAC, 50/60 Hz (1 min)			
Functional	Mutual Interference Prevention (Scan Code)	This function prevents mutual interference in up to two F3SG-RA-25-02TS systems.		
	Cascade Connection	Number of cascaded segments: 3 max. (only among F3SG-4RA□□□□-25-02TS's)		
		Total number of beams: 255 max. Cable length between sensors: 10 m max. (not including cascading cable (F39-JGR2WTS) and power cable)		
	Test Function	Self-test (at power-on, and during operation) External test (light emission stop function by test input)		
Safety-Related Functions	External device monitoring (EDM) Scan code selection			
Environmental	Ambient Temperature	Operating	-10 to 55°C (14 to 131°F) (non-icing)	
		Storage	-25 to 70°C (-13 to 158°F)	
	Ambient Humidity	Operating	35% to 85% (non-condensing)	
		Storage	35% to 95%	
	Ambient Illuminance	Incandescent lamp: 3,000 lx max. on receiver surface Sunlight: 10,000 lx max. on receiver surface		
	Degree of Protection (IEC 60529)	IEC 60529: IP65 and IP67, JIS C 0920 Annex 1: IP67G		
	Vibration Resistance (IEC 61496-1)	Class 3M4 (IEC TR 60721-4-3) Operation limit: 5 to 150 Hz, Multiple amplitude of 7 mm, Acceleration of 1 G, 10 sweeps each in X, Y, and Z directions (no delay at resonant frequencies)		
Shock Resistance (IEC 61496-1)	Class 3M4 (IEC TR 60721-4-3) Operation limit: Acceleration of 15 G, Pulse duration of 6 ms, 100 shocks for each in X, Y, and Z directions (600 shocks in total)			
Pollution Degree (IEC 60664-1)	Pollution Degree 3			

		F3SG-4RA□□□□-25-02TS	
Connections	Power cable	Type of Connection	M12 connectors: 8-pin emitter and receiver. Cables prewired to the sensors. IP67 and IP67G (JIS C 0920 Annex 1) * rated when mated. * F3SG-RA-25-02TS meets the degree of protection when it is correctly connected with an F39-JD□□RA-□ Oil-Resistant extension cable.
		Number of Wires	Emitter: 5, Receiver: 8
		Cable Length	0.3 m
		Cable Diameter	6 mm
		Minimum Bending Radius	R36 mm
	Cascading cable	Type of Connection	M12 connectors: 8-pin emitter and receiver. IP67 rated when mated.
		Number of Wires	Emitter: 5, Receiver: 8
		Cable Length	0.3 m
		Minimum Bending Radius	R5 mm
	F39-JD□□RA-□ Oil-Resistant cable - Single-Ended Cable	Type of Connection	M12 connectors: 8-pin emitter and receiver. Cables prewired to the sensors. IP67 and IP67G (JIS C 0920 Annex 1)* rated when mated. * F3SG-RA-25-02TS meets the degree of protection when it is correctly connected with the power cable. The degree of protection is not satisfied with the part where cable wires are uncovered.
		Number of Wires	Emitter: 5, Receiver: 8
		Cable Length	Refer to page 122.
		Cable Diameter	6 mm
		Minimum Bending Radius	R36 mm
	Extension cable - Single-Ended Cable (F39-JD□A) - Double-Ended Cable (F39-JD□B)	Type of Connection	M12 connectors: 8-pin emitter and receiver. IP67 rated when mated.
Number of Wires		Emitter: 8, Receiver: 8	
Cable Length		Refer to page 122 and 123.	
Minimum Bending Radius		R36 mm	
Extension of Power Cable		100 m max. (Emitter/Receiver)	
Material	Material	Housing: Aluminum alloy Cap: PBT resin Front window: Acrylic resin Cable: Fluororesin FE plate: Stainless steel	
	Weight	Refer to page 128 .	
	Included Accessories	Safety Precautions, Quick Installation Manual, Troubleshooting Guide Sticker, End Cap (for switching External Test Input function)	
Conformity	Conforming standards	Refer to page 129.	
	Performance Level (PL)/Safety category	PL e/Category 4 (EN ISO 13849-1:2015)	
	PFH <sub>d</sub>	1.1 × 10 <sup>-8</sup> (IEC 61508)	
	Proof test interval T <sub>M</sub>	Every 20 years (IEC 61508)	
	SFF	99% (IEC 61508)	
	HFT	1 (IEC 61508)	
Classification		Type B (IEC 61508-2)	

## Bluetooth Communication Unit

Communication System	Bluetooth Version 3.0
Communication Profile	SPP (Serial Port Profile)
Transmission Distance	Approx. 10 m max. (Output power: Class 2) *

\* It depends on use environment conditions.

# F3SG-RA-02TS

## List of Models/Response Time/Current Consumption/Weight

Model	Number of Beams	Protective Height [mm] (Overall length)	Response Time [ms] *1			Current Consumption [mA]		Weight [kg]	
			ON → OFF *2	OFF (Synchronized) → ON	OFF (Not synchronized) → ON	Emitter	Receiver	Net *3	Gross *4
F3SG-4RA0240-25-02TS	12	240	8	40	140	35	75	0.7	1.6
F3SG-4RA0320-25-02TS	16	320	8	40	140	40	75	0.9	1.9
F3SG-4RA0400-25-02TS	20	400	8	40	140	45	75	1.1	2.1
F3SG-4RA0480-25-02TS	24	480	8	40	140	50	75	1.3	2.4
F3SG-4RA0560-25-02TS	28	560	8	40	140	50	75	1.5	2.7
F3SG-4RA0640-25-02TS	32	640	8	40	140	55	75	1.7	3.0
F3SG-4RA0720-25-02TS	36	720	8	40	140	60	80	1.9	3.2
F3SG-4RA0800-25-02TS	40	800	8	40	140	65	80	2.1	3.5
F3SG-4RA0880-25-02TS	44	880	13	65	165	50	80	2.3	3.8
F3SG-4RA0960-25-02TS	48	960	13	65	165	50	80	2.5	4.0
F3SG-4RA1040-25-02TS	52	1040	13	65	165	55	80	2.7	4.3
F3SG-4RA1120-25-02TS	56	1120	13	65	165	55	85	2.9	4.6
F3SG-4RA1200-25-02TS	60	1200	13	65	165	55	85	3.1	4.9
F3SG-4RA1280-25-02TS	64	1280	13	65	165	60	85	3.3	5.1
F3SG-4RA1360-25-02TS	68	1360	13	65	165	60	85	3.5	5.4
F3SG-4RA1440-25-02TS	72	1440	13	65	165	65	85	3.7	5.7
F3SG-4RA1520-25-02TS	76	1520	13	65	165	65	90	3.9	5.9
F3SG-4RA1600-25-02TS	80	1600	13	65	165	70	90	4.1	6.2
F3SG-4RA1680-25-02TS	84	1680	13	65	165	70	90	4.3	6.5
F3SG-4RA1760-25-02TS	88	1760	13	65	165	70	90	4.5	6.7
F3SG-4RA1840-25-02TS	92	1840	13	65	165	75	90	4.7	7.0
F3SG-4RA1920-25-02TS	96	1920	13	65	165	75	95	4.9	7.3

\*1. The maximum speed of movement of a test rod up to which the detection capability is maintained is 2.0 m/s.

\*2. The response times are values when Scan Code is set at Code B. The response times for Code A are 1 ms shorter than these values.

\*3. The net weight is the weight of an emitter and a receiver.

\*4. The gross weight is the weight of an emitter, a receiver, included accessories and a package.

## Legislation and Standards

1. The F3SG-RA-02TS does not receive type approval provided by Article 44-2 of the Industrial Safety and Health Act of Japan. When using the F3SG-RA-02TS in Japan as a "safety system for pressing or shearing machines" prescribed in Article 42 of that law, the machine control system must receive type approval.
2. The F3SG-RA-02TS is electro-sensitive protective equipment (ESPE) in accordance with European Union (EU) Machinery Directive Index Annex V, Item 2.
3. EC/EU Declaration of Conformity  
OMRON declares that the F3SG-RA-02TS is in conformity with the requirements of the following EC/EU Directives:  
Machinery Directive 2006/42/EC  
EMC Directive 2014/30/EU
4. Conforming Standards
  - (1) European standards  
EN61496-1 (Type 4 ESPE), EN 61496-2 (Type 4 AOPD), EN61508-1 through -4 (SIL 3), EN ISO 13849-1:2015 (PL e, Category 4)
  - (2) International standards  
IEC61496-1 (Type 4 ESPE), IEC61496-2 (Type 4 AOPD), IEC61508-1 through -4 (SIL 3), ISO 13849-1:2015 (PL e, Category 4)
  - (3) JIS standards  
JIS B 9704-1 (Type 4 ESPE), JIS B 9704-2 (Type 4 AOPD)
  - (4) North American standards  
UL61496-1 (Type 4 ESPE), UL61496-2 (Type 4 AOPD), UL508, UL1998, CAN/CSA C22.2 No.14, CAN/CSA C22.2 No.0.8
5. Third-Party Certifications
  - (1) TÜV SÜD
    - EC Type-Examination certificate:  
EU Machinery Directive, Type 4 ESPE (EN61496-1), Type 4 AOPD (EN 61496-2)
    - Certificate:  
Type 4 ESPE (EN61496-1), Type 4 AOPD (EN61496-2), EN 61508-1 through -4 (SIL 3), EN ISO 13849-1:2015 (PL e, Category 4)
  - (2) UL
    - UL Listing:  
Type 4 and ESPE (UL61496-1), Type 4 AOPD (UL61496-2), UL508, UL1998, CAN/CSA C22.2 No.14, CAN/CSA C22.2 No.0.8
6. Other Standards  
The F3SG-RA-02TS is designed according to the standards listed below. To make sure that the final system complies with the following standards and regulations, you are asked to design and use it in accordance with all other related standards, laws, and regulations. If you have any questions, consult with specialized organizations such as the body responsible for prescribing and/or enforcing machinery safety regulations in the location where the equipment is to be used.
  - European Standards: EN415-4, EN691-1, EN692, EN693, IEC 62046
  - U.S. Occupational Safety and Health Standards: OSHA 29 CFR 1910.212
  - U.S. Occupational Safety and Health Standards: OSHA 29 CFR 1910.217
  - American National Standards: ANSI B11.1 to B11.19
  - American National Standards: ANSI/RIA R15.06
  - Canadian Standards Association CSA Z142, Z432, Z434
  - SEMI Standards SEMI S2
  - Japan Ministry of Health, Labour and Welfare "Guidelines for Comprehensive Safety Standards of Machinery", Standard Bureau's Notification No. 0731001 dated July 31, 2007.rms and Conditions Agreement

# F3SG-RA-02TS

## Indicator

### Emitter

Name of Indicator		Color	Illuminated	Blinking
Test	TEST	Green	–	External Test is being performed
Operating range	LONG	Green	Always illuminated	Lockout state due to Scan code setting error
Power	POWER	Green	Power is ON.	Error due to noise
Lockout	LOCKOUT	Red	–	Lockout state due to error in emitter

### Receiver

Name of Indicator		Color	Illuminated	Blinking
Top-beam-state	TOP	Blue	The top beam is unblocked	Lockout state due to Cap error or Other sensor error
PNP/NPN mode	NPN	Green	Always illuminated	–
Configuration	CFG	Green	–	Lockout state due to Parameter error or Cascading Configuration error
External device monitoring	EDM	Green	EDM input is in ON state *	Lockout state due to EDM error
Internal error	INTERNAL	Red	–	Lockout state due to Internal error, or error due to abnormal power supply or noise
Lockout	LOCKOUT	Red	–	Lockout state due to error in receiver
Stable-state	STB	Green	Incident light level is 170% or higher of ON-threshold	Safety output is instantaneously turned OFF due to ambient light or vibration
ON/OFF	ON/OFF	Green	Safety output is in ON state	–
		Red	Safety output is in OFF state	Lockout state due to Safety Output error, or error due to abnormal power supply or noise
Communication	COM	Green	Synchronization between emitter and receiver is maintained	Lockout state due to Communication error, or error due to abnormal power supply or noise
Bottom-beam state	BTM	Blue	The bottom beam is unblocked	Lockout state due to Scan code setting error

**Note:** TOP, CFG, LOCKOUT, STB and ON/OFF indicators are illuminated when the receiver of the F3SG-RA-02TS is in Setting mode.

\* The EDM indicator is illuminated when the EDM input is in the ON state regardless of the use of the EDM function.

### Interface Unit

<b>Main Unit</b>	PC/AT compatible machine (computer that runs Microsoft Windows)
<b>Operating System (OS)</b>	Windows 7 (32-bit/64-bit), Windows 8, 8.1 (32-bit/64-bit), Windows 10 (32-bit/64-bit)
<b>Communication Port</b>	USB port ×1
<b>Ambient Temperature</b>	Operating: -10 to 55°C, Storage: -30 to 70°C (non-icing and non-condensing)
<b>Ambient Humidity</b>	Operating: 35% to 85%, Storage: 35% to 95% (non-condensing)

### Lamp

Item	F39-LP
<b>Applicable Sensor</b>	F3SG-□RA Series Safety Light Curtain (Receiver)
<b>LED Light Color</b>	Red/Green/Orange
<b>Power Supply Voltage</b>	24 VDC±20%, ripple p-p 10% max. (shares sensor's power supply)
<b>Current Consumption</b>	25 mA max. (shares sensor's power supply.)
<b>Ambient Temperature</b>	Operating: -10 to 55°C, Storage: -25 to 70°C
<b>Ambient Humidity</b>	Operating: 35% to 85%, Storage: 35% to 95%
<b>Vibration Resistance</b>	10 to 55 Hz, Multiple amplitude of 0.7 mm, 20 sweeps for all 3 axes
<b>Shock Resistance</b>	100 m/s <sup>2</sup> , 1000 shocks for all 3 axes
<b>Degree of Protection</b>	IP65 and IP67 (When attached to F3SG)
<b>Type of Connection</b>	Connectable to F3SG-RA's terminal connector
<b>Material</b>	Lighting element: PC, Other body parts: PBT
<b>Weight</b>	45 g (when packaged)

# Connections (Basic Wiring Diagram)

## Standalone F3SG-RA-02TS

### EDM used and External Test in 24V Active not used

The following is the example of External Device Monitoring used and External Test in 24 V Active not used.

### Settings

	Function
Receiver	EDM
Emitter	External Test: 24 V Active (End Cap: Black) (factory default setting)

### Wiring Example

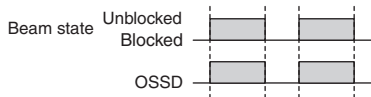
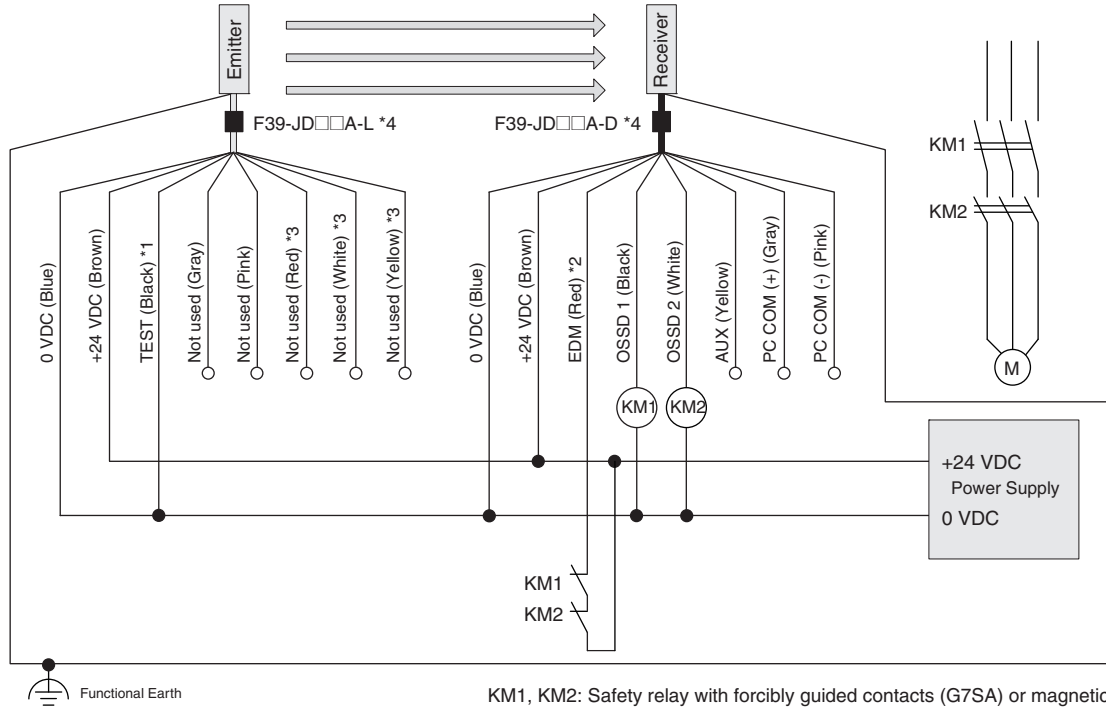

KM1, KM2: Safety relay with forcibly guided contacts (G7SA) or magnetic contactor  
M: Motor

- \*1. Connect the line to 24 V via a test switch (N.O. contact) if External Test is used.
- \*2. Connect a lockout reset switch (NC contact) to this line in series with the KM1 and KM2 if Lockout Reset is used.
- \*3. The F39-JD□□RA-L Single-Ended Cable for Emitter (Oil-Resistant Cable) does not have the red, white and yellow wires.
- \*4. For the F39-JD□□A-□ Single-Ended Cable, connect the shield line to 0 V.

**Note:** Functional earth connection is unnecessary when you use the F3SG-RA-02TS in a general industrial environment where noise control or stable power supply is considered. However, when you use the F3SG-RA-02TS in an environment where there may be excessive noise from surroundings or stable power supply may be interfered, it is recommended the F3SG-RA-02TS be connected to functional earth.

The wiring examples in later examples do not indicate functional earth. To use functional earth, wire an earth cable according to the example above. Refer to *Safety Light Curtain F3SG-RA-02TS Series User's Manual* for more information.

## Connectable Safety Control Units

The F3SG-RA-02TS can be connected to the safety control units listed in the table below.

Connectable Safety Control Units		
Safety Relay Units	Flexible Safety Units	Safety Controllers
G9SA-301		G9SP-N10S
G9SA-321-T□		G9SP-N10D
G9SA-501		G9SP-N20S
G9SB-200-B	G9SX-AD322-T	NE0A-SCPU01
G9SB-200-D	G9SX-ADA222-T	NE1A-SCPU01
G9SB-301-B	G9SX-BC202	NE1A-SCPU02
G9SB-301-D	G9SX-GS226-T15	DST1-ID12SL-1
G9SE-201		DST1-MD16SL-1
G9SE-401		DST1-MRD08SL-1
G9SE-221-T□		NX-SIH400
		NX-SID800
		F3SP-T01

# Input/Output Circuit

## Entire Circuit Diagram

The entire circuit diagram of the F3SG-RA-02TS is shown below. The numbers in the circles indicate the connector's pin numbers.

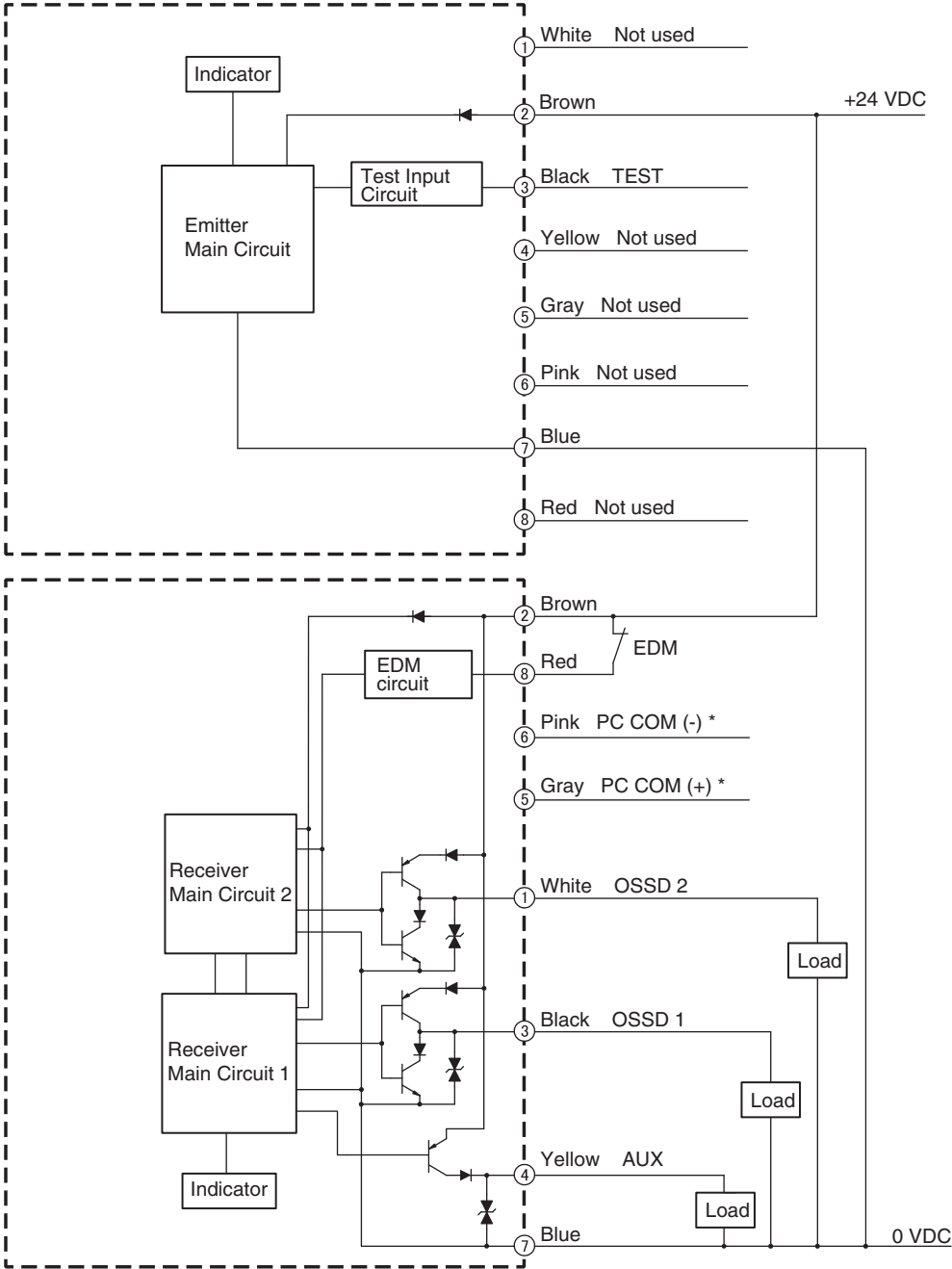

\* This line is used for communication with a PC using the F39-GIF-1 Interface Unit.

F3SG-RA-02TS

## Input Circuit Diagram by Function

The input circuit diagrams of by function are shown below.

### Test Input

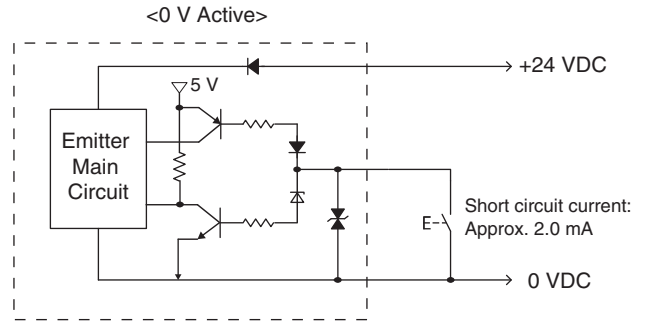
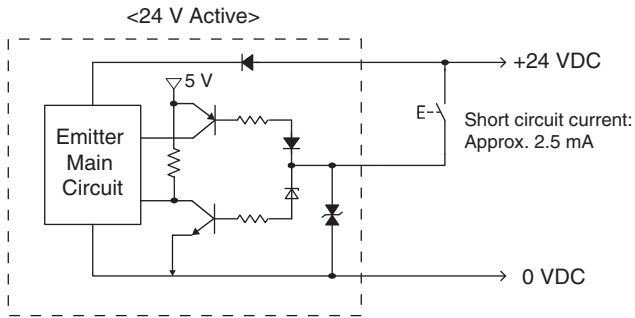

### EDM

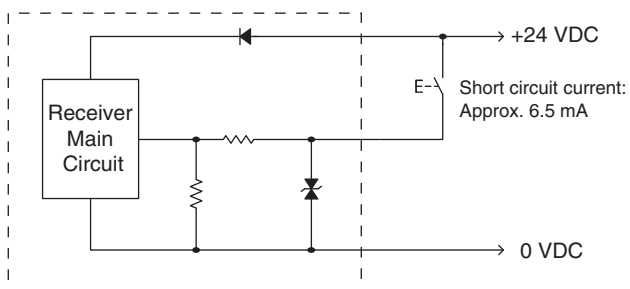

# Dimensions

## Mounted with Free-Location Brackets (F39-LGRA)

### Backside Mounting

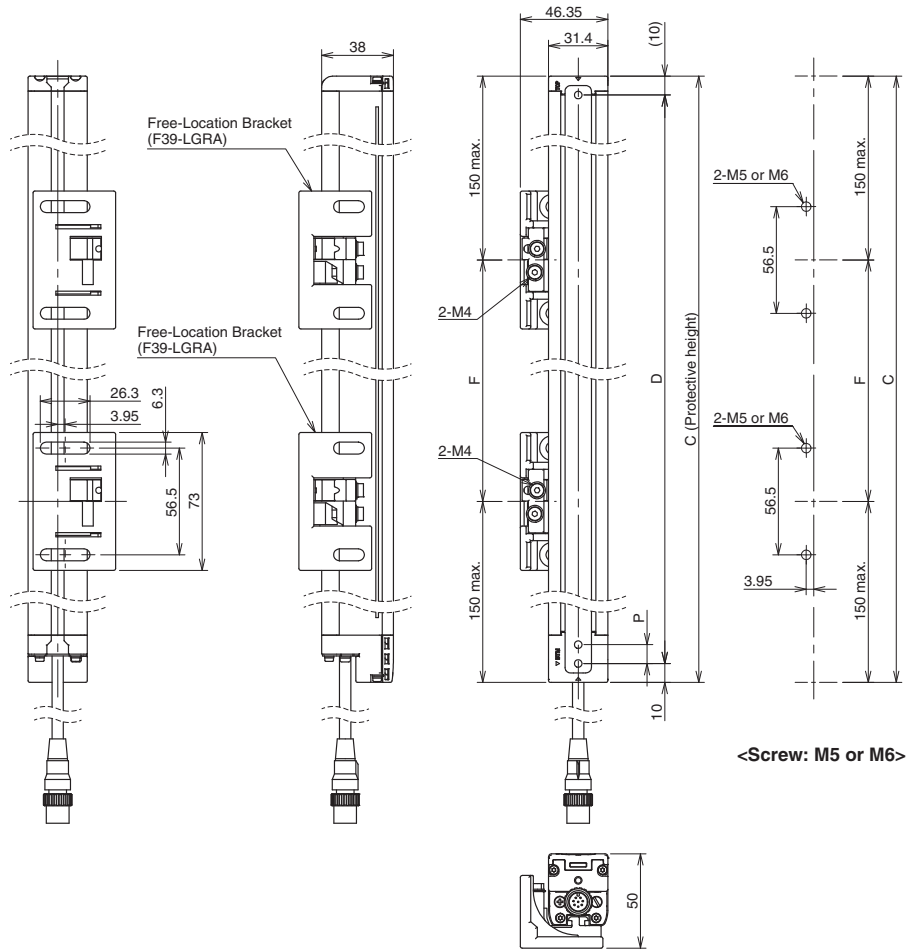

#### F3SG-4RA-□□□□-25-02TS Series

Dimension C	4-digit number of the type name (Protective height)
Dimension D	C-20
Dimension P	20

Protective height (C)	Number of Free-Location Brackets *1	Dimension F
0240 to 1200	2 *2	1000 mm max.
1280 to 1920	3	1000 mm max.

\*1. The number of brackets required to mount either one of emitter and receiver.

\*2. Mounting an emitter or receiver with one bracket is possible for the model of protective height of 0240. In this case, locate this bracket at half the Dimension C (or at the center of the sensor length).

F3SG-RA-02TS

## Side Mounting

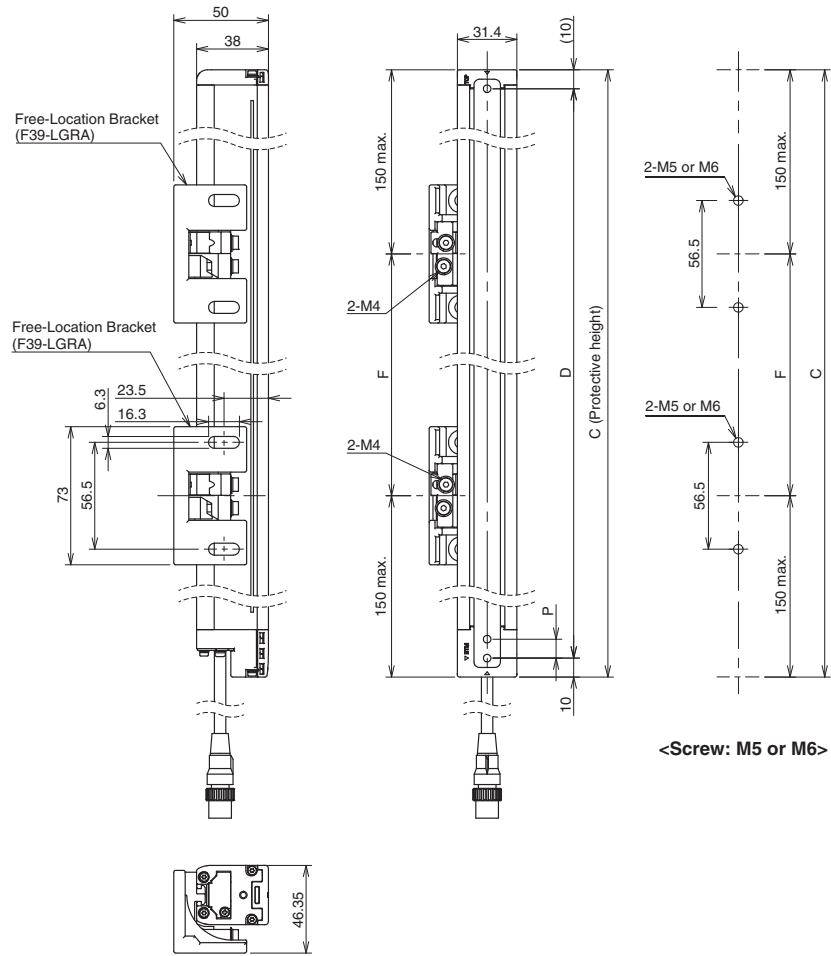

### F3SG-4RA-□□□□-25-02TS Series

Dimension C	4-digit number of the type name (Protective height)
Dimension D	C-20
Dimension P	20

Protective height (C)	Number of Free-Location Brackets *1	Dimension F
0240 to 1200	2 *2	1000 mm max.
1280 to 1920	3	1000 mm max.

\*1. The number of brackets required to mount either one of emitter and receiver.

\*2. Mounting an emitter or receiver with one bracket is possible for the model of protective height of 0240. In this case, locate this bracket at half the Dimension C (or at the center of the sensor length).

**Mounted with Top/Bottom Brackets (F39-LGRTB) and Intermediate Bracket (F39-LGRA)  
Backside Mounting**

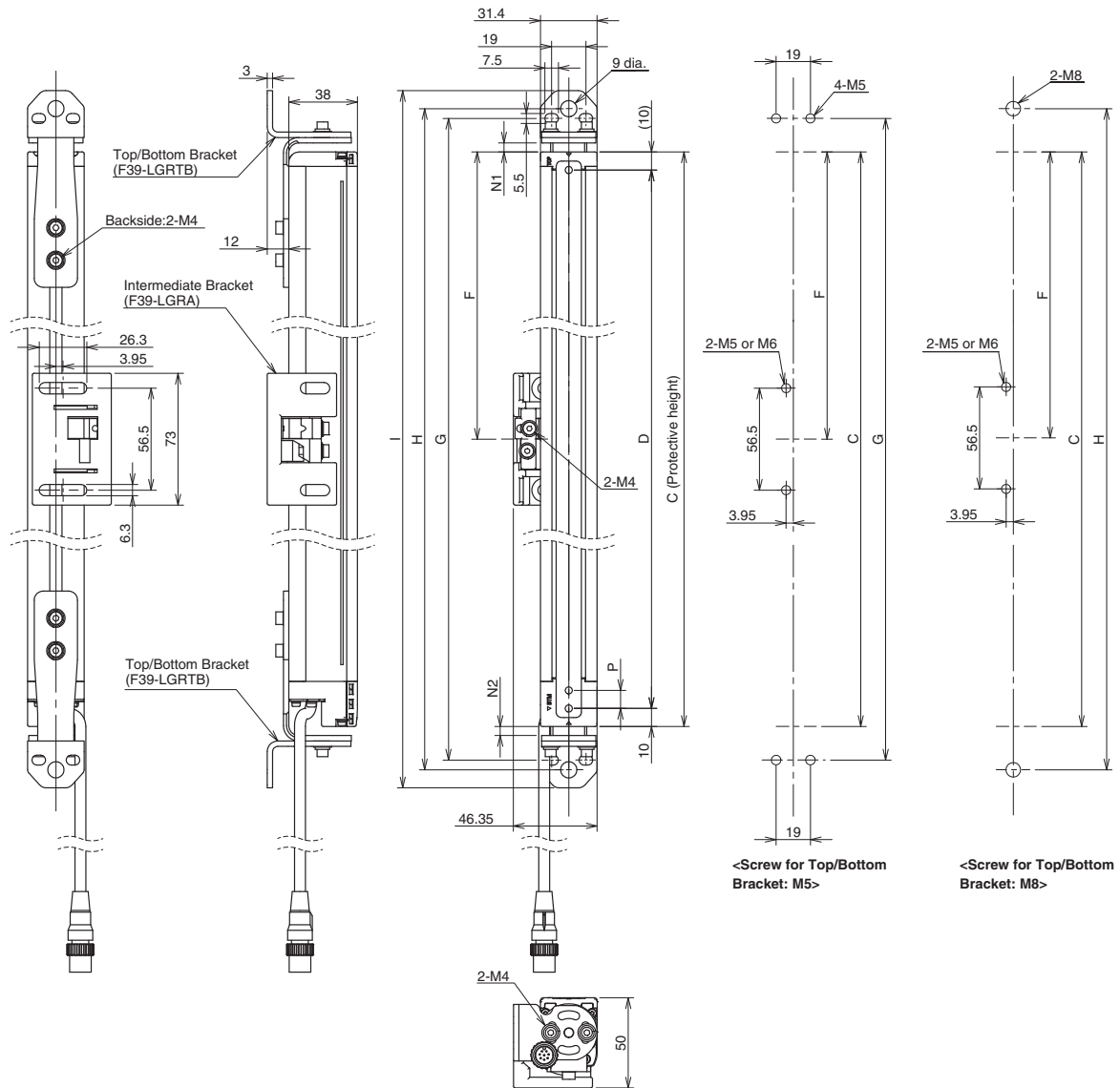

**F3SG-4RA-□□□□-25-02TS Series**

Dimension C	4-digit number of the type name (Protective height)
Dimension D	C-20
Dimension G	$C+27.2+N1+N2$
Dimension H	$C+38+N1+N2$
Dimension I	$C+58+N1+N2$
Dimension N1	0 to 30
Dimension N2	0 to 13
Dimension P	20

Protective height (C)	Number of Top/Bottom Brackets *	Number of Intermediate Brackets *	Dimension F
0240 to 1040	2	0	-
1120 to 1920	2	1	1000 mm max.

\* The number of brackets required to mount either one of emitter and receiver.

F3SG-RA-02TS

# F3SG-RA-02TS

## Side Mounting

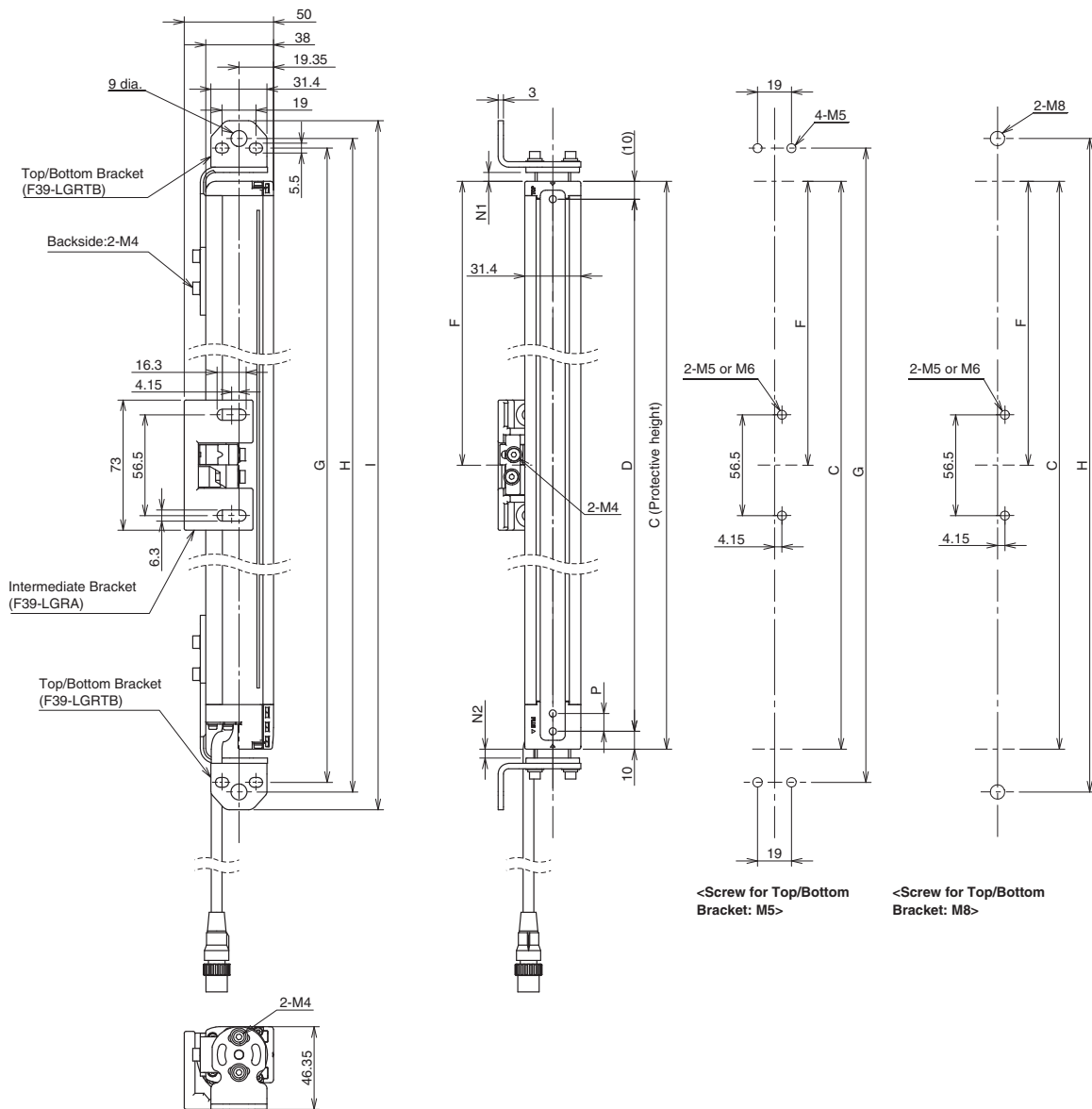

### F3SG-4RA-□□□□-25-02TS Series

Dimension C	4-digit number of the type name (Protective height)
Dimension D	C-20
Dimension G	$C+27.2+N1+N2$
Dimension H	$C+38+N1+N2$
Dimension I	$C+58+N1+N2$
Dimension N1	0 to 30
Dimension N2	0 to 13
Dimension P	20

Protective height (C)	Number of Top/Bottom Brackets *	Number of Intermediate Brackets *	Dimension F
0240 to 1040	2	0	-
1120 to 1920	2	1	1000 mm max.

\* The number of brackets required to mount either one of emitter and receiver.

Mounted with Top/Bottom Brackets (F39-LGRTB-2) and Intermediate Bracket (F39-LGRA)  
Backside Mounting

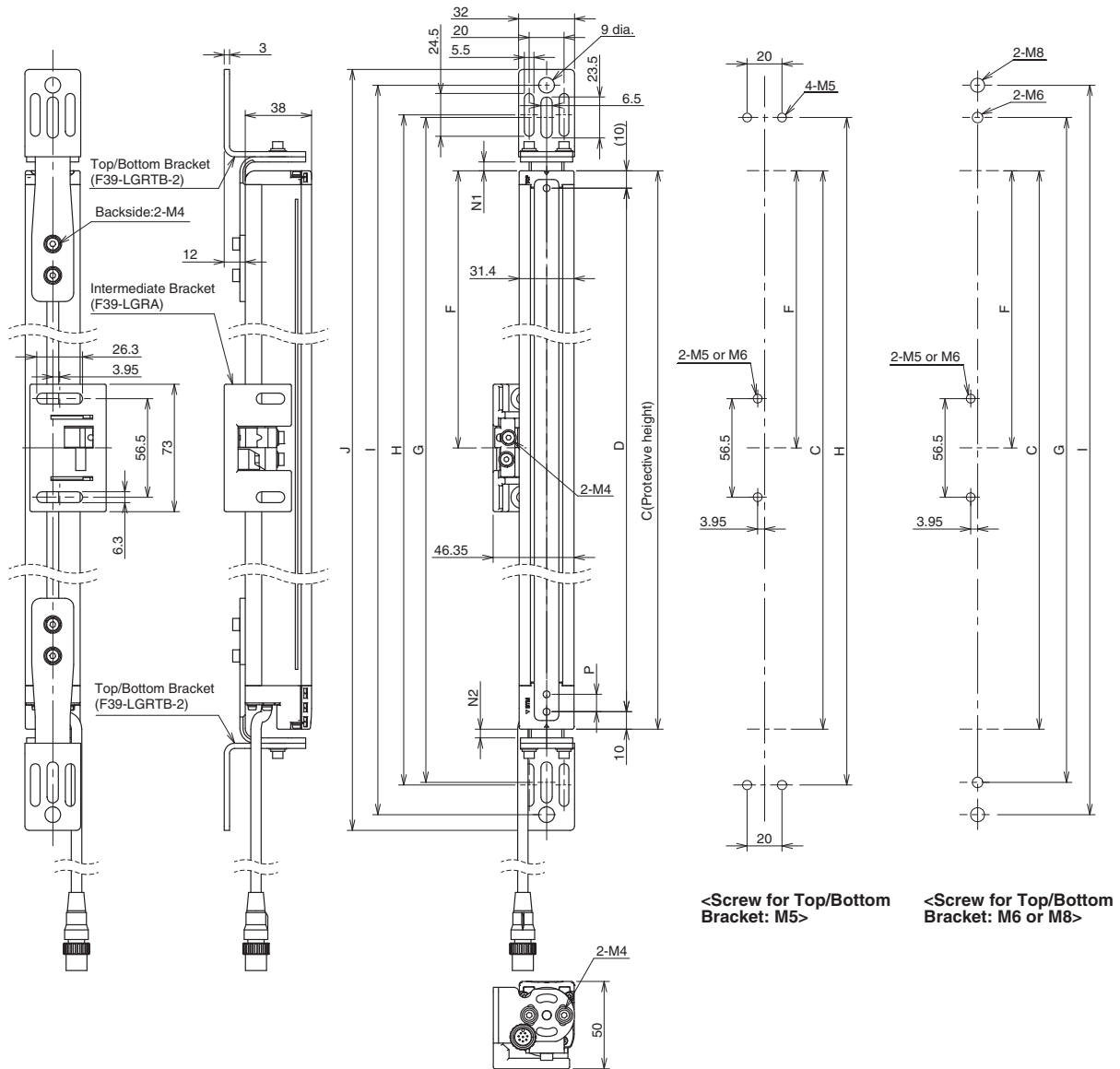

<Screw for Top/Bottom Bracket: M5>

<Screw for Top/Bottom Bracket: M6 or M8>

F3SG-4RA-□□□□-25-02TS Series

Dimension C	4-digit number of the type name (Protective height)
Dimension D	C-20
Dimension G	$C+51+N1+N2$
Dimension H	$C+54+N1+N2$
Dimension I	$C+88+N1+N2$
Dimension J	$C+106+N1+N2$
Dimension N1	0 to 30
Dimension N2	0 to 13
Dimension P	20

Protective height (C)	Number of Top/Bottom Brackets *	Number of Intermediate Brackets *	Dimension F
0240 to 1040	2	0	-
1120 to 1920	2	1	1000 mm max.

\* The number of brackets required to mount either one of emitter and receiver.

F3SG-RA-02TS

# F3SG-RA-02TS

## Side Mounting

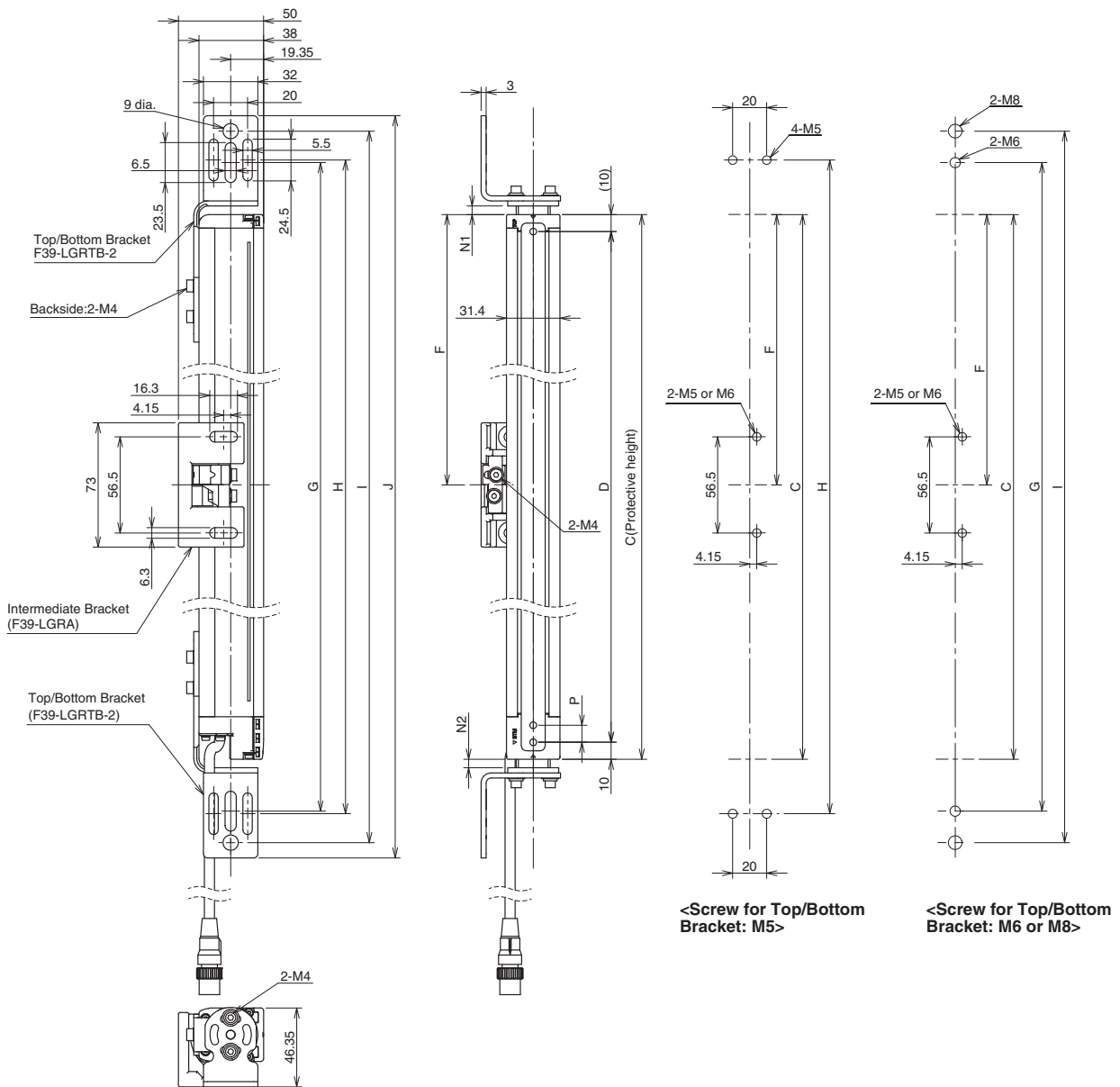

### F3SG-4RA-□□□□-25-02TS Series

<b>Dimension C</b>	4-digit number of the type name (Protective height)
<b>Dimension D</b>	C-20
<b>Dimension G</b>	$C+51+N1+N2$
<b>Dimension H</b>	$C+54+N1+N2$
<b>Dimension I</b>	$C+88+N1+N2$
<b>Dimension J</b>	$C+106+N1+N2$
<b>Dimension N1</b>	0 to 30
<b>Dimension N2</b>	0 to 13
<b>Dimension P</b>	20

Protective height (C)	Number of Top/Bottom Brackets *	Number of Intermediate Brackets *	Dimension F
0240 to 1040	2	0	-
1120 to 1920	2	1	1000 mm max.

\* The number of brackets required to mount either one of emitter and receiver.

**Mounted with Top/Bottom Brackets (F39-LGRTB-3) and Intermediate Bracket (F39-LGRA)  
Backside Mounting**

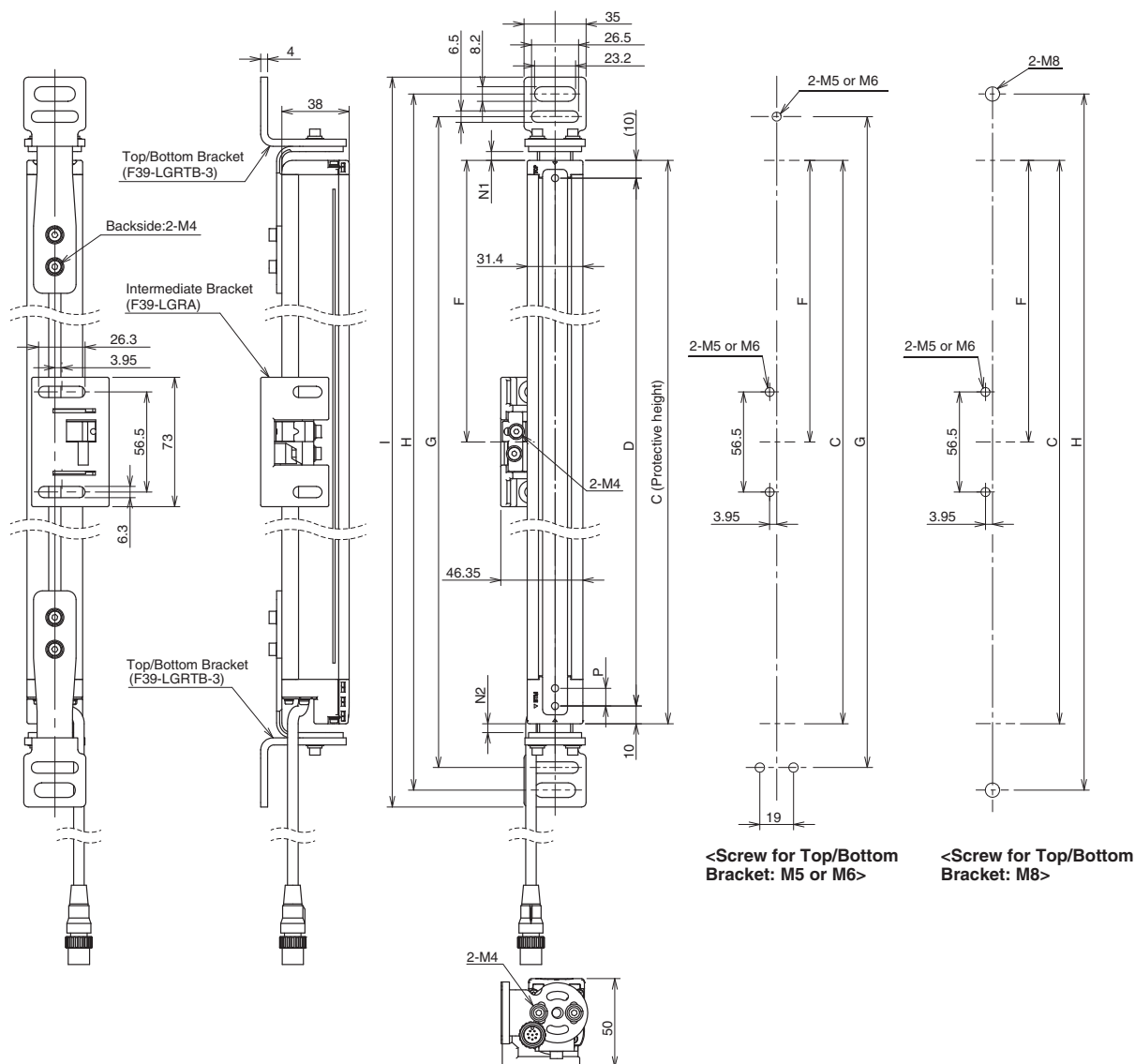

**F3SG-4RA-□□□□-25-02TS Series**

Dimension C	4-digit number of the type name (Protective height)
Dimension D	C-20
Dimension G	$C+39.5+N1+N2$
Dimension H	$C+65+N1+N2$
Dimension I	$C+84+N1+N2$
Dimension N1	0 to 30
Dimension N2	0 to 13
Dimension P	20

Protective height (C)	Number of Top/Bottom Brackets *	Number of Intermediate Brackets *	Dimension F
0240 to 1040	2	0	-
1120 to 1920	2	1	1000 mm max.

\* The number of brackets required to mount either one of emitter and receiver.

F3SG-RA-02TS

# F3SG-RA-02TS

## Side Mounting

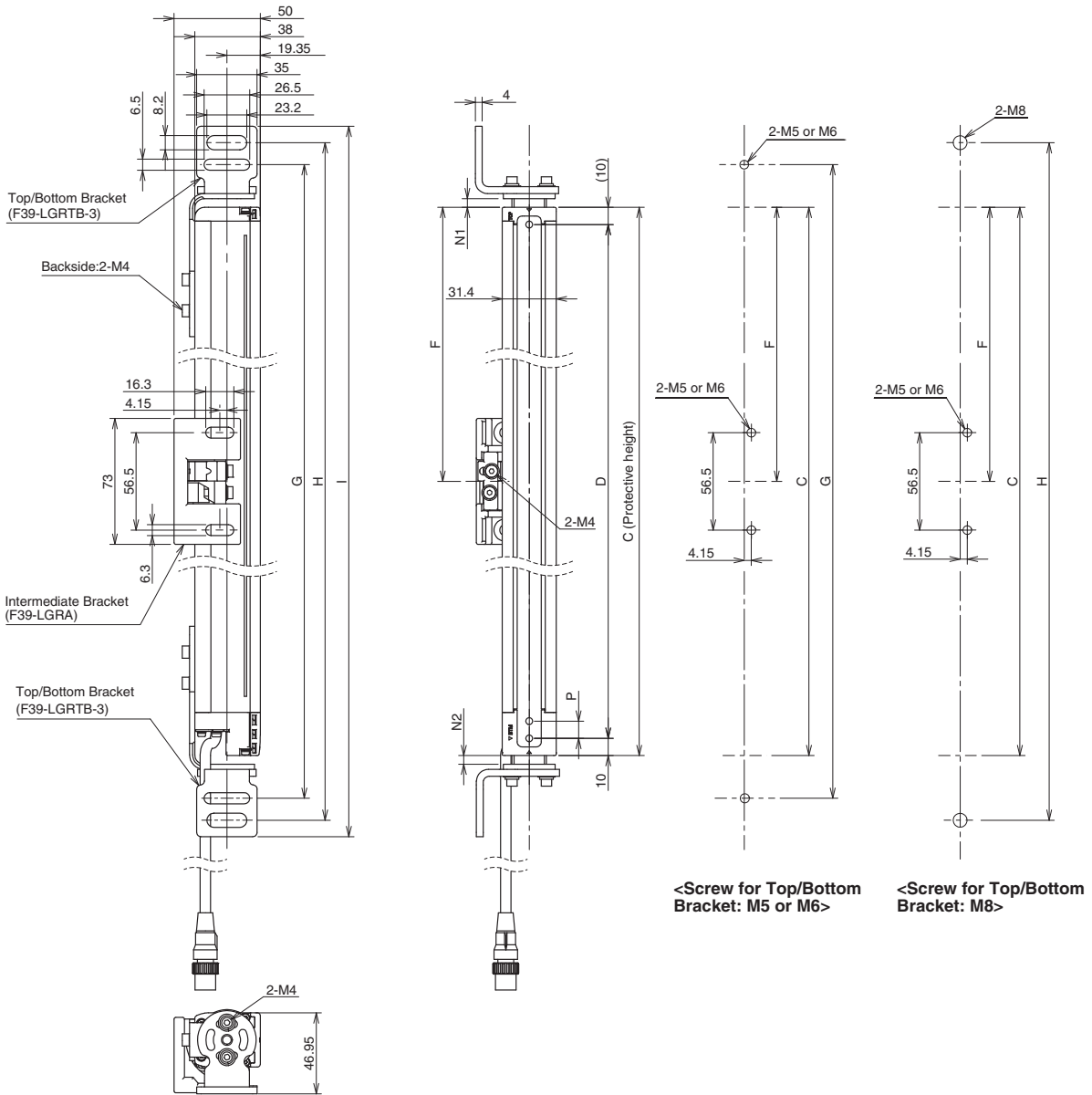

### F3SG-4RA-□□□□-25-02TS Series

Dimension C	4-digit number of the type name (Protective height)
Dimension D	C-20
Dimension G	$C+39.5+N1+N2$
Dimension H	$C+65+N1+N2$
Dimension I	$C+84+N1+N2$
Dimension N1	0 to 30
Dimension N2	0 to 13
Dimension P	20

Protective height (C)	Number of Top/Bottom Brackets *	Number of Intermediate Brackets *	Dimension F
0240 to 1040	2	0	-
1120 to 1920	2	1	1000 mm max.

\* The number of brackets required to mount either one of emitter and receiver.

**Accessories**

**Sensor Mounting Brackets**  
**Free-Location Bracket / Intermediate Bracket**  
**(F39-LGRA, sold separately)**

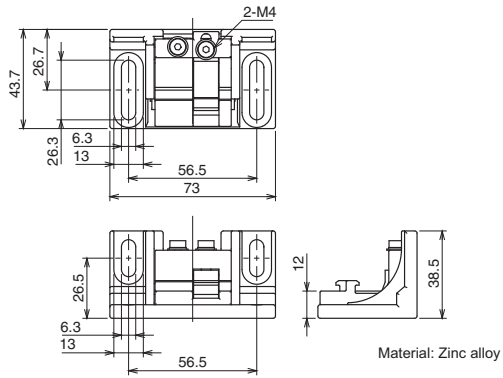

**Top/Bottom Bracket**  
**(F39-LGRTB, sold separately)**

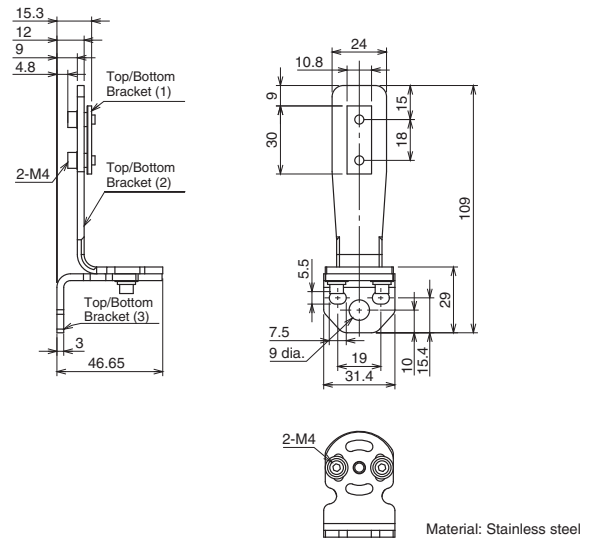

**Top/Bottom Bracket**  
**(F39-LGRTB-2, sold separately)**

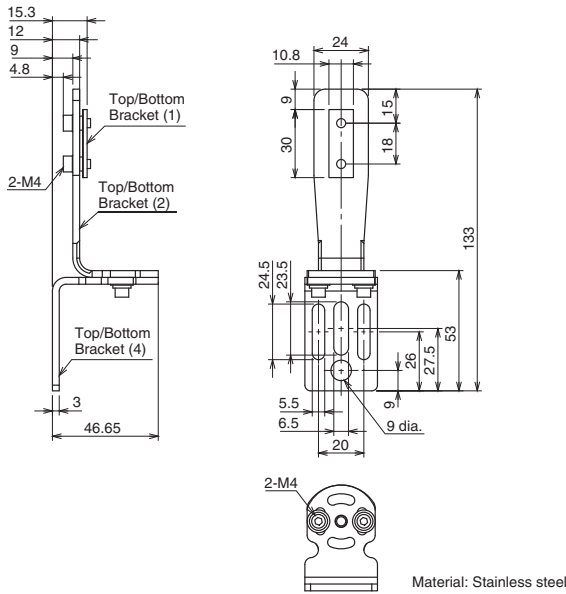

**Top/Bottom Bracket**  
**(F39-LGRTB-3, sold separately)**

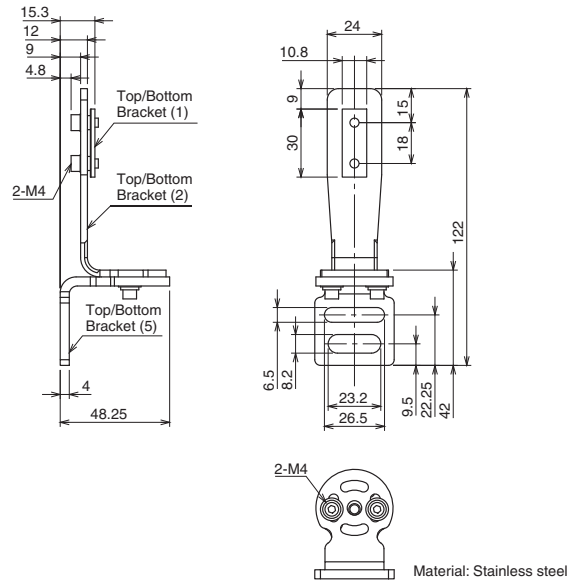

F3SG-RA-02TS

# F3SG-RA-02TS

## Safety light curtain connecting cable

### Single-Ended Cable for Emitter (Oil-Resistant Cable) (F39-JD□RA-L, sold separately)

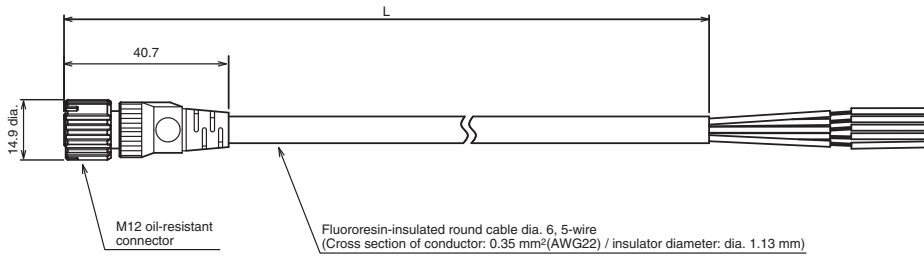

### Single-Ended Cable for Receiver (Oil-Resistant Cable) (F39-JD□RA-D, sold separately)

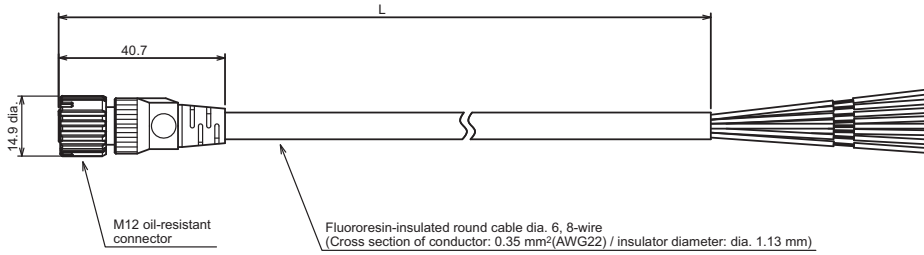

Emitter cable (Gray)	Receiver cable (Black)	L (m)
F39-JD3RA-L	F39-JD3RA-D	3
F39-JD7RA-L	F39-JD7RA-D	7

### Single-Ended Cable for Emitter (F39-JD□A-L, sold separately)

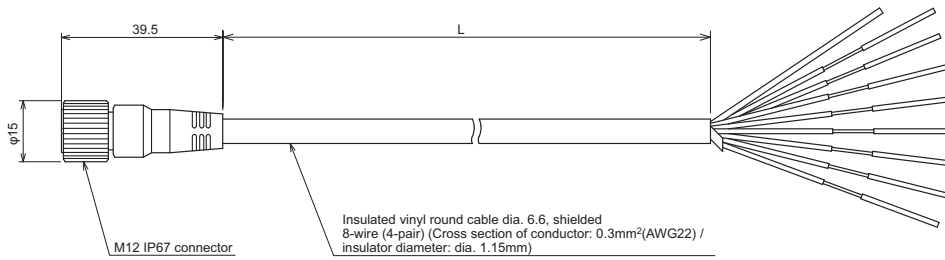

### Single-Ended Cable for Receiver (F39-JD□A-D, sold separately)

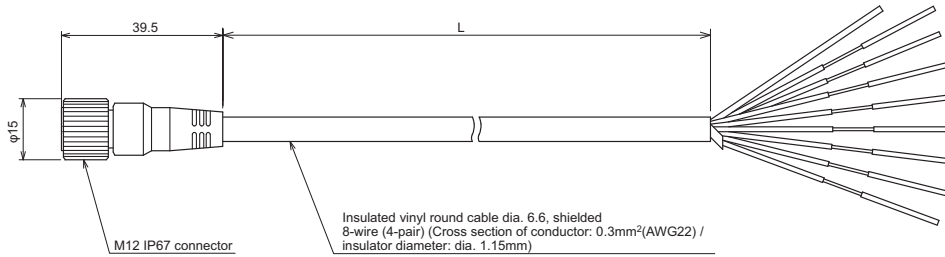

Emitter cable (Gray)	Receiver cable (Black)	L (m)
F39-JD3A-L	F39-JD3A-D	3
F39-JD7A-L	F39-JD7A-D	7
F39-JD10A-L	F39-JD10A-D	10
F39-JD15A-L	F39-JD15A-D	15
F39-JD20A-L	F39-JD20A-D	20

### Double-Ended Cable for Emitter: Cable for extension (F39-JD□B-L, sold separately)

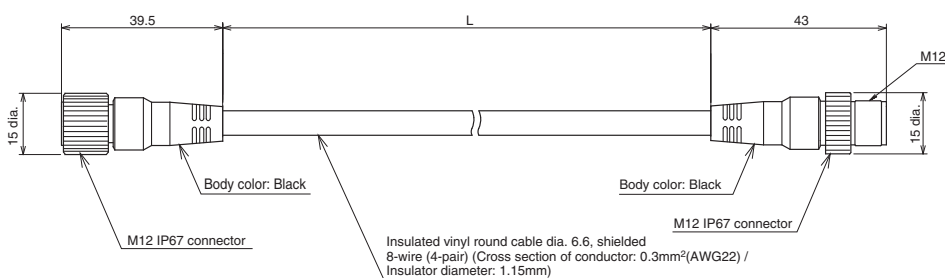

**Double-Ended Cable for Receiver: Cable for extension (F39-JD□B-D, sold separately)**

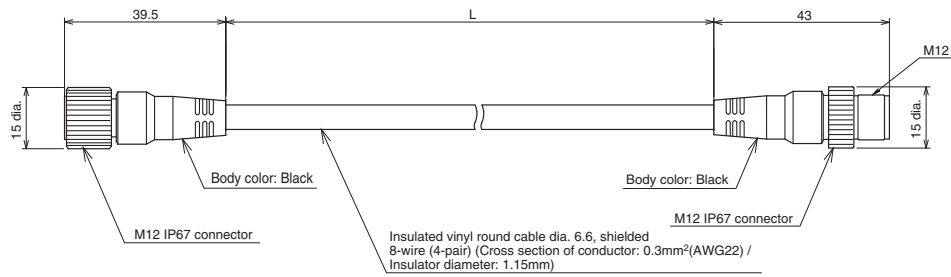

Emitter cable (Gray)	Receiver cable (Black)	L (m)
F39-JDR5B-L	F39-JDR5B-D	0.5
F39-JD1B-L	F39-JD1B-D	1
F39-JD3B-L	F39-JD3B-D	3
F39-JD5B-L	F39-JD5B-D	5
F39-JD7B-L	F39-JD7B-D	7
F39-JD10B-L	F39-JD10B-D	10
F39-JD15B-L	F39-JD15B-D	15
F39-JD20B-L	F39-JD20B-D	20

**Reduced Wiring Connector (F39-CN5, sold separately)**

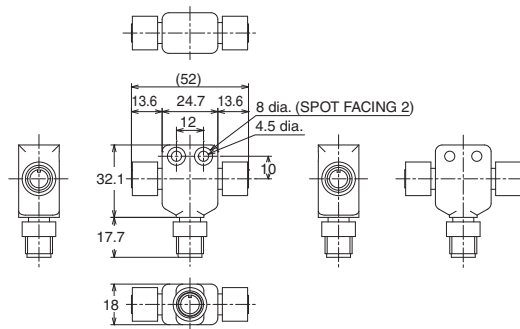

**Cascading Cable for Emitter (F39-JGR2WTS-L, sold separately)**

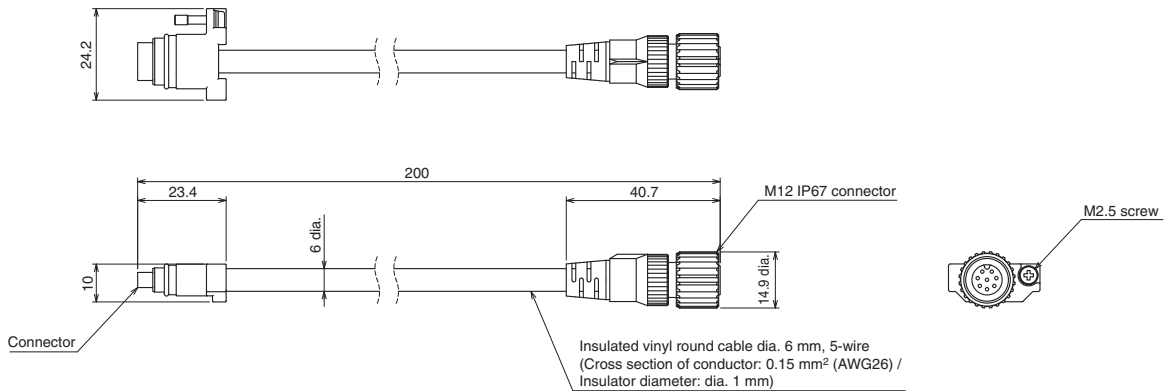

**Cascading Cable for Receiver (F39-JGR2WTS-D, sold separately)**

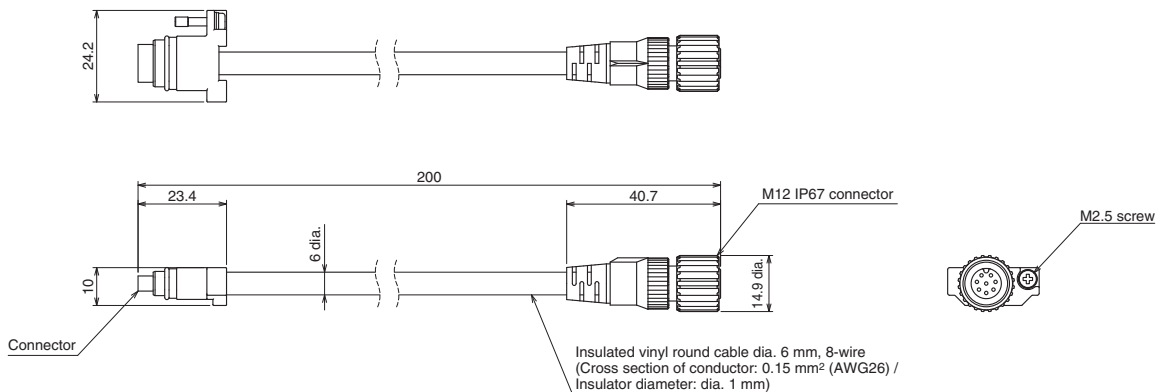

Set model name	Emitter cable (Gray)	Receiver cable (Black)	L (m)
F39-JGR2WTS	F39-JGR2WTS-L	F39-JGR2WTS-D	0.2

F3SG-RA-02TS

# F3SG-RA-02TS

## Interface Unit (F39-GIF-1, sold separately)

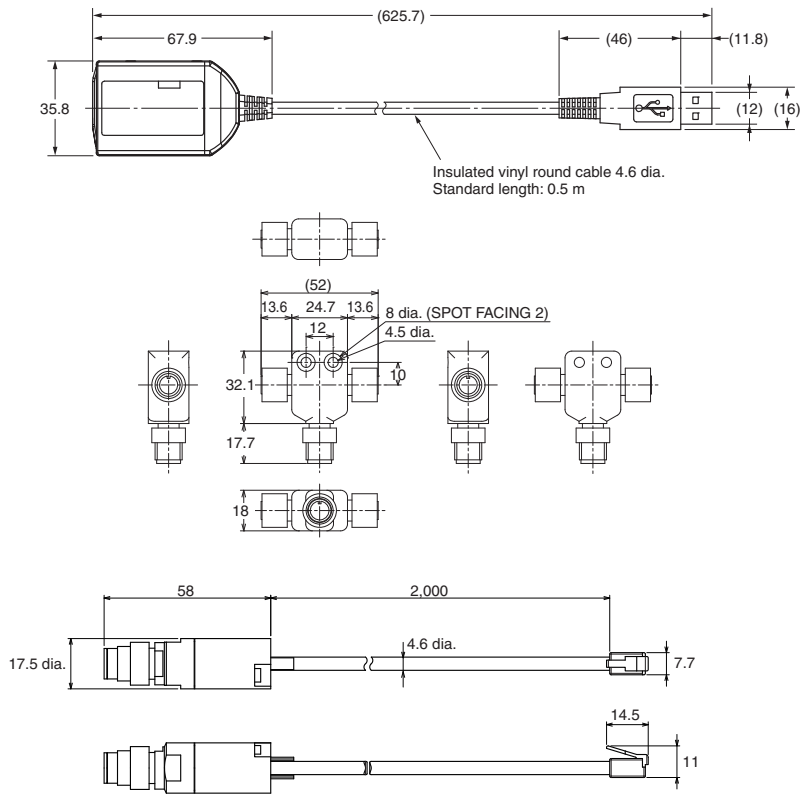

## Bluetooth Communication Unit (F39-BT, sold separately)

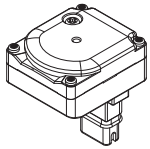

Material: PBT

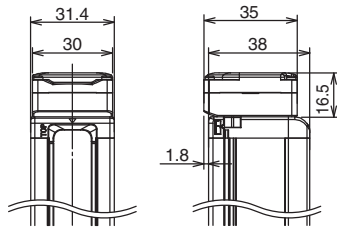

## Lamp and Bluetooth Communication Unit (F39-BTLP, sold separately) Lamp (F39-LP, sold separately)

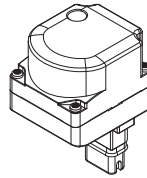

Material:  
PC (Lighting element)  
PBT (Other body parts)

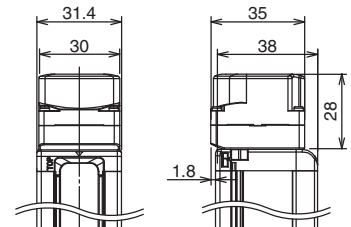

## Related Manuals

ManNo.	Model	Manual name
Z391	F3SG-4RA□□□□-25-02TS	Safety Light Curtain F3SG-4RA□□□□-25-02TS Series User's Manual

# Smart Muting Actuator F3W-MA

## Integrated muting sensor based on multi-beam photoelectric sensor



- A muting system can be configured easily in combination with the safety light curtain.
- Muting functions can be stably performed even when workpieces with holes pass.



## System Configuration

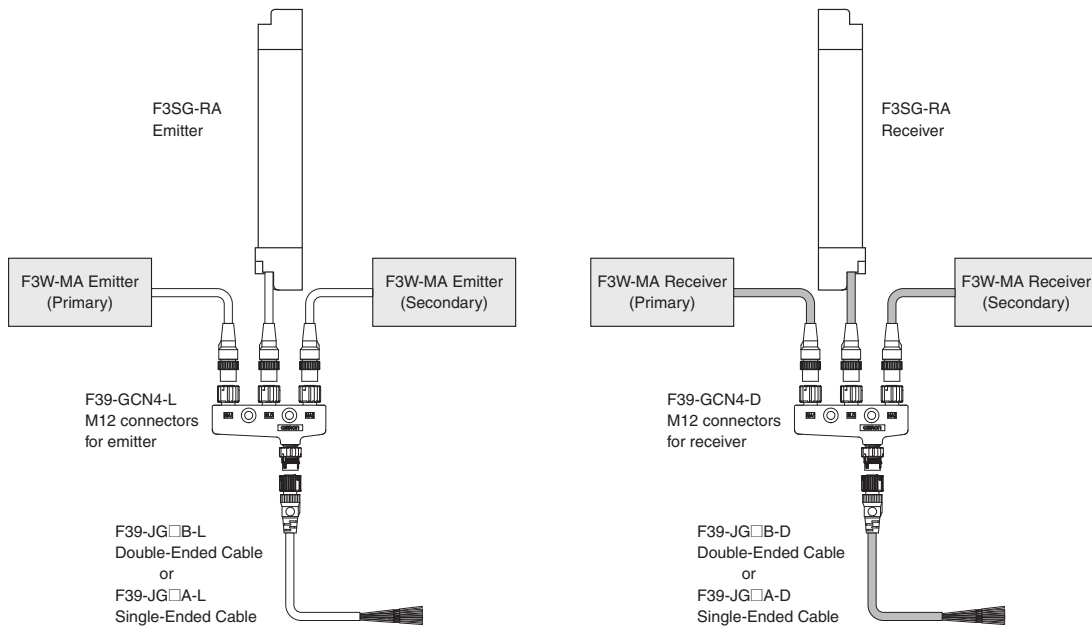

# F3W-MA

## Ordering Information



### Smart Muting Actuator

Appearance	Beam Gap between Muting Trigger Beams	output	Number of Beams	Model
	100 mm	PNP output	8	F3W-MA0100P
	300 mm		20	F3W-MA0300P

Note: Use with the PNP output model safety light curtain.



### Accessories (Sold separately)

#### Single-Ended Cable \*

Appearance	Type	Cable length	Specifications	Model																							
	M12 connector (5-pin), 5 wires Color: Gray	3 m	Connected to Power Cable or Double-Ended Cable  Female <table border="1"> <tr><td>1</td><td>+24 VDC</td><td>Brown</td></tr> <tr><td>2</td><td>CFG In</td><td>Black</td></tr> <tr><td>3</td><td>0 VDC</td><td>Blue</td></tr> <tr><td>4</td><td>COM+</td><td>White</td></tr> <tr><td>5</td><td>COM-</td><td>Yellow</td></tr> </table>	1	+24 VDC	Brown	2	CFG In	Black	3	0 VDC	Blue	4	COM+	White	5	COM-	Yellow	F39-JG3A-L								
		1		+24 VDC	Brown																						
		2		CFG In	Black																						
		3		0 VDC	Blue																						
		4		COM+	White																						
	5	COM-	Yellow																								
	7 m	F39-JG7A-L																									
	10 m	F39-JG10A-L																									
	15 m	F39-JG15A-L																									
	20 m	F39-JG20A-L																									
For receiver M12 connector (8-pin), 8 wires Color: Black	3 m	Connected to Power Cable or Double-Ended Cable  Female <table border="1"> <tr><td>1</td><td>MUTE Enable / CFG In / Reset</td><td>Yellow</td></tr> <tr><td>2</td><td>+24 VDC</td><td>Brown</td></tr> <tr><td>3</td><td>COM+</td><td>Gray</td></tr> <tr><td>4</td><td>COM-</td><td>Pink</td></tr> <tr><td>5</td><td>Muting Output A</td><td>Black</td></tr> <tr><td>6</td><td>Muting Output B</td><td>White</td></tr> <tr><td>7</td><td>0 VDC</td><td>Blue</td></tr> <tr><td>8</td><td>CFG Out</td><td>Red</td></tr> </table>	1	MUTE Enable / CFG In / Reset	Yellow	2	+24 VDC	Brown	3	COM+	Gray	4	COM-	Pink	5	Muting Output A	Black	6	Muting Output B	White	7	0 VDC	Blue	8	CFG Out	Red	F39-JG3A-D
	1		MUTE Enable / CFG In / Reset	Yellow																							
	2		+24 VDC	Brown																							
	3		COM+	Gray																							
	4		COM-	Pink																							
5	Muting Output A	Black																									
6	Muting Output B	White																									
7	0 VDC	Blue																									
8	CFG Out	Red																									
7 m	F39-JG7A-D																										
10 m	F39-JG10A-D																										
15 m	F39-JG15A-D																										
20 m	F39-JG20A-D																										

\* A set of two Single-Ended Cables (one for emitter and one for receiver) is also available.  
Model: Model number without the -L/-D at the end (F39-JG□A)

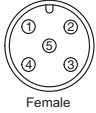
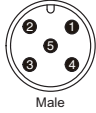
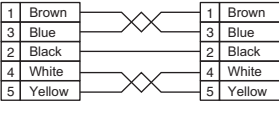

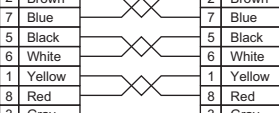



#### Double-Ended Cable \*

Appearance	Type	Cable length	Specifications	Model
	M12 connector (5-pin) on both ends Color: Gray	0.5 m	Connected to Power Cable or Double-Ended Cable  Female Connected to Single-Ended Cable, or Double-Ended Cable  Male 	F39-JGR5B-L
		1 m		F39-JG1B-L
		3 m		F39-JG3B-L
		5 m		F39-JG5B-L
		7 m		F39-JG7B-L
		10 m		F39-JG10B-L
		15 m		F39-JG15B-L
	20 m	F39-JG20B-L		
	M12 connector (8-pin) on both ends Color: Black	0.5 m	Connected to Power Cable or Double-Ended Cable  Female Connected to Single-Ended Cable, or Double-Ended Cable  Male 	F39-JGR5B-D
		1 m		F39-JG1B-D
		3 m		F39-JG3B-D
		5 m		F39-JG5B-D
		7 m		F39-JG7B-D
		10 m		F39-JG10B-D
15 m		F39-JG15B-D		
20 m	F39-JG20B-D			

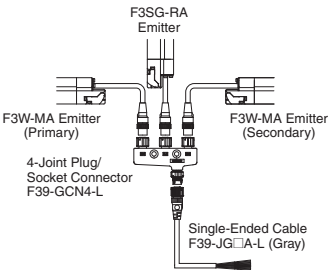
\* A set of two Double-Ended Cables (one for emitter and one for receiver) is also available.  
Model: Model number without the -L/-D at the end (F39-JG□B)

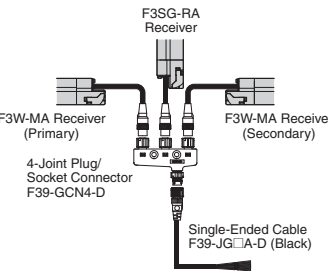

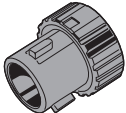

**4-Joint Plug/Socket Connector**

Used for reduced wiring for connecting F3W-MA with F3SG-RA.

Appearance	Type	Specifications	Model
	For emitter M12 connectors. Used for reduced wiring.		<b>F39-GCN4-L</b>
	For receiver (PNP output) M12 connectors. Used for reduced wiring.		<b>F39-GCN4-D</b>
	Includes one each of F39-GCN4-L and F39-GCN4-D	—	<b>F39-GCN4</b>
	Water-resistive Cover for 4-Joint Plug/Socket Connector	One water-resistive cover for an F39-GCN4-L/-D 4-Joint Plug/Socket Connector. You can use this when the MA2 connector part is not used. Material: PBT. IP67 rated when attached. Smartclick mechanism.	<b>XS5Z-11</b>
	Dust Cover for 4-Joint Plug/Socket Connector	One dust cover for an F39-GCN4-L/-D 4-Joint Plug/Socket Connector. You can use this when the MA2 connector part is not used. Material: Rubber/black. This cover does not ensure IP67 degree of protection.	<b>XS2Z-14</b>
		XS2Z-14: Attach to a pin block inside the M12 female screw. XS2Z-15: Attach to a M12 female screw. When attaching the cover to the connector, press the cover onto the connector until the connector is fully inserted into the cover.	<b>XS2Z-15</b>

# F3W-MA

## Sensor Mounting Brackets

Appearance	Specification	Application	Remarks	Model
	Standard Fixed Bracket	Bracket to mount the F3W-MA. Side mounting and backside mounting possible.	Two brackets per set	<b>F39-LGF</b>
	Standard Adjustable Bracket	Bracket to mount the F3W-MA. Beam alignment after mounting possible. The angle adjustment range is $\pm 15^\circ$ . Side mounting and backside mounting possible.	Two brackets per set	<b>F39-LGA</b>
	F3W-MA Bracket	Bracket to fix the F3W-MA to the F3SG-RA. F39-LGMAL: L-shaped configuration F39-LGMAT: T-shaped configuration Beam alignment after mounting possible. When using the F3W-MA Bracket, it is necessary to add an extra Standard Adjustable Bracket (F39-LGA) to the F3SG-RA. * Please also purchase Standard Adjustable Bracket (F39-LGA).	Two brackets per set	<b>F39-LGMAL</b>
				<b>F39-LGMAT</b>

**Note:** When mounting an F3W-MA0300P in the L-shaped configuration, the shock resistance becomes as follows.

Shock resistance: 50 m/s<sup>2</sup>, 1000 shocks for all 3 axes

For mounting an F3W-MA0300P under a shock environment exceeding this, the F3W-MA Bracket cannot be used. Use a Standard Adjustable Bracket (F39-LGA).

\* When using F39-LGMA□, there are some restrictions on the brackets to mount the F3SG-RA. This bracket is not usable together with F39-LGF. When using together with the F39-LGA, the protective height of the F3SG-RA must be 270 mm or longer. When using together with F39-LGTB, the protective height of the F3SG-RA must be 400 mm or longer. An extra F39-LGA is required for reinforcement, depending on the mounting position of the F39-LGMA□. Refer to "Dimensions" on page 159 for details.

## Ratings/Specifications

		F3W-MA0100P	F3W-MA0300P	
Performance	Beam Gap between Muting Trigger Beams	100 mm	300 mm	
	Number of Beams	8	20	
	Standard Detection Object	30 mm		
	Operating Range	Long	0.3 to 20.0 m (1 to 65 ft.)	
		Short	0.3 to 7.0 m (1 to 23 ft.)	
	Response Time	Operation	13 ms max.	
		Reset	26 ms max. (Synchronized) 78 ms max. (Not synchronized)	
	Effective Aperture Angle	±2.5° max., emitter and receiver at operating range of 3 m or greater		
Light Source	Infrared LEDs, Wavelength: 870 nm			
Startup Waiting Time	2 s max.			
Electrical	Power Supply Voltage (Vs)	SELV/PELV 24 VDC±20% (ripple p-p 10% max.)		
	Current Consumption	Emitter	35 mA	45 mA
		Receiver	75 mA	75 mA
	Muting Outputs	Two PNP transistor outputs. * Load current of 300 mA max., Residual voltage of 2 V max. (except for voltage drop due to cable extension))		
		* This product is a PNP output model. Use with the PNP output model safety light curtain.		
	Output Operation Mode	Muting Output A	Dark-ON (Muting Output A is enabled when MUTE A trigger beam is blocked.)	
		Muting Output B	Dark-ON (Muting Output B is enabled when MUTE B trigger beam is blocked.)	
	Input Voltage	ON Voltage	[MUTE Enable] Vs to Vs-3 V (sink current 5 mA max.) *	
		OFF Voltage	[MUTE Enable] 0 to 1/2 Vs, or open *	
		* The Vs indicates a supply voltage value in your environment.		
Indicators	Refer to page 152. LED Indicator Status			
Protective Circuit	Protective Circuit Output short protection, Power supply reverse polarity protection			
Insulation Resistance	20 MΩ or higher (500 VDC megger)			
Dielectric Strength	1,000 VAC, 50/60 Hz (1 min)			
Functional	Functions	<ul style="list-style-type: none"> <li>- Scan Code Selection</li> <li>- Operation Mode Selection (Point to Point Detection/ Chattering and Void Space Prevention)</li> <li>- Off-Delay</li> <li>- Muting Enable</li> <li>- Muting Trigger Beam Allocation</li> <li>- Operating Range Selection</li> </ul>		
Environmental	Ambient Temperature	Operating	-10 to 55°C (13 to 131°F) (non-icing)	
		Storage	-25 to 70°C (-13 to 158°F)	
	Ambient Humidity	Operating	35% to 85% (non-condensing)	
		Storage	35% to 95%	
	Ambient Illuminance	Incandescent lamp: 3,000 lx max. on receiver surface Sunlight: 10,000 lx max. on receiver surface		
	Degree of Protection (IEC 60529)	IP65 and IP67		
	Vibration Resistance (IEC 61496-1)	10 to 55 Hz, Multiple amplitude of 0.7 mm, 20 sweeps for all 3 axes		
Shock Resistance (IEC 61496-1)	100 m/s <sup>2</sup> , 1000 shocks for all 3 axes			
Pollution Degree (IEC 60664-1)	Pollution Degree 3			
Connections	Power Cable	Type of Connection	M12 connectors: 5-pin emitter, 8-pin receiver, IP67 rated when mated, Cables prewired to sensors	
		Number of Wires	Emitter: 5, Receiver: 8	
		Cable Length	0.3 mm	
		Cable Diameter	6 mm	
		Minimum Bending Radius	R5 mm	
Extension of Power Cable	100 m max. Note: For T-Shaped configuration with COM lines, the length of cable extension is 30m max.			
Material	Housing: Aluminum alloy, Cap: PBT resin, Front window: Acrylic resin, Cable: Oil-resistant PVC resin, FE plate: Stainless steel			
Net Weight *1	0.7 kg	0.9 kg		
Gross Weight *2	1.3 kg	2.2 kg		
Included Accessories	Instruction Sheet			

\*1. The net weight is the weight of an emitter and a receiver.

\*2. The gross weight is the weight of an emitter, a receiver, included accessories and a package.

# F3W-MA

## LED Indicator Status

Shown below are indication statuses of F3W-MA LED indicators when you purchased.

### Emitter

Name of Indicator		Color	Illuminated	Blinking
Operating range	LONG	Green	Long Range mode is selected by DIP Switch.	-
Running	RUN	Green	Power is ON.	-
Error	ERR	Red	-	Error in emitter. Generic error happens.

### Receiver

Name of Indicator		Color	Illuminated	Blinking
Top-beam-state	TOP	Blue	The top beam is unblocked.	-
Muting output A	MUTE A	Green	Muting Output A is activated.	-
Muting output B	MUTE B	Green	Muting Output B is activated.	-
Off-Delay	DELAY	Yellow	Off-Delay function is enabled by DIP Switch.	-
Chattering/ Void space	CHAT	Green	Chattering and Void Space Prevention mode is selected by DIP Switch.	-
Muting Enable	MUTE DISABLE	Red	The Muting Enable function is enabled and Muting Enable input is turned OFF by DIP Switch.	-
Error	ERR	Red	-	Error in receiver. Generic error happens.
Stable-state	STB	Green	Incident light level is 170% or higher of ON-threshold	-
Running	RUN	Green	Power is ON.	-
Communication	COM	Green	Synchronization between emitter and receiver is maintained.	[Primary sensor] - Start-up (for approx. 3 s) - Synchronization between emitter and receiver is lost
Bottom-beamstate	BTM	Blue	The bottom beam is unblocked.	-

## Wiring Examples

### Standard Muting Mode with F3SG-R (T-Shaped Configuration with COM lines)

The following is the example of F3W-MA with Scan Code B, Chattering and Void Space Prevention 1, Off-Delay 100 ms and Muting Enable disabled.

#### DIP Switch settings \*1

		Function	DIP-SW1	DIP-SW2 *2
F3W-MA Primary	Receiver	Scan Code B (factory default setting)	1 <input checked="" type="checkbox"/> ON	1 <input checked="" type="checkbox"/> ON
		Chattering and Void Space Prevention 1	2 <input checked="" type="checkbox"/> ON 3 <input checked="" type="checkbox"/> ON	2 <input checked="" type="checkbox"/> ON 3 <input checked="" type="checkbox"/> ON
		Off-Delay 100 ms	4 <input checked="" type="checkbox"/> ON 5 <input checked="" type="checkbox"/> ON	4 <input checked="" type="checkbox"/> ON 5 <input checked="" type="checkbox"/> ON
		Muting Enable Disabled (factory default setting)	6 <input checked="" type="checkbox"/> ON	6 <input checked="" type="checkbox"/> ON
	Emitter	Scan Code B (factory default setting)	1 <input checked="" type="checkbox"/> ON	-
F3W-MA Secondary	Receiver Emitter	-	No setting required	No setting required

☐: Indicates a switch position.

\*1. Configure functions with the DIP Switches before wiring. Refer to *Smart Muting Actuator F3W-MA Series User's Manual* for more information.

\*2. DIP Switch Bank 2 is not used.

#### Wiring example

[Emitter]

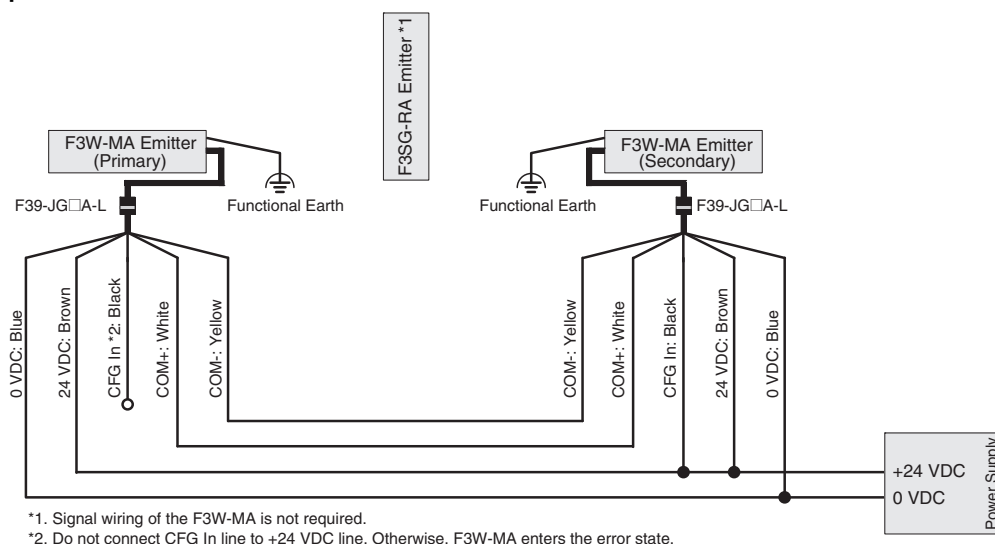

[Receiver]

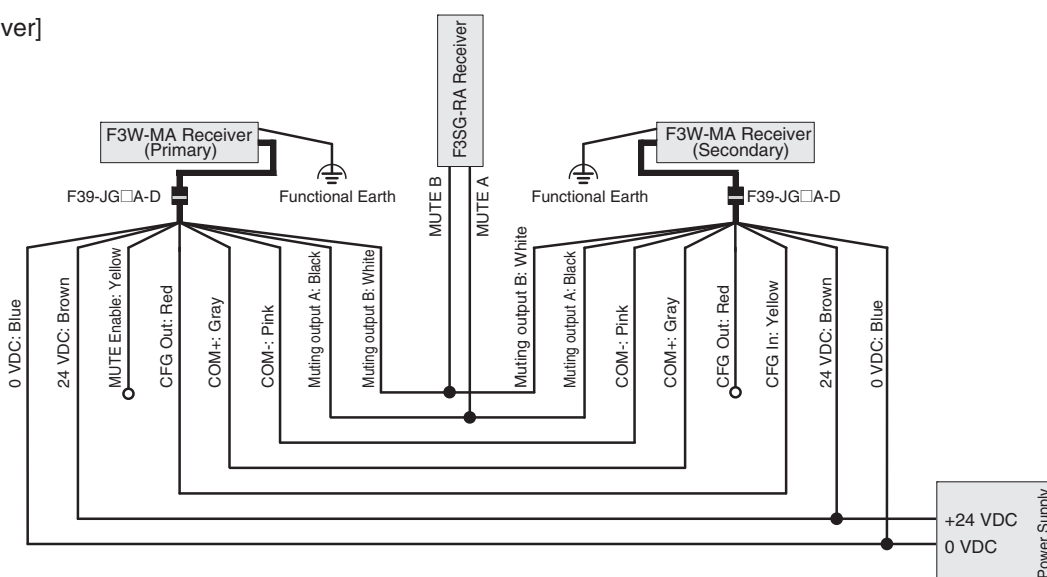

**Note:** The wiring examples in later pages do not indicate functional earth. To use functional earth, wire an earth cable according to the example above. Refer to *Smart Muting Actuator F3W-MA Series User's Manual* for more information.

# F3W-MA

## Input/Output Circuit

The entire circuit diagram of the F3W-MA is shown below.  
The numbers in the circles indicate the connector's pin numbers.

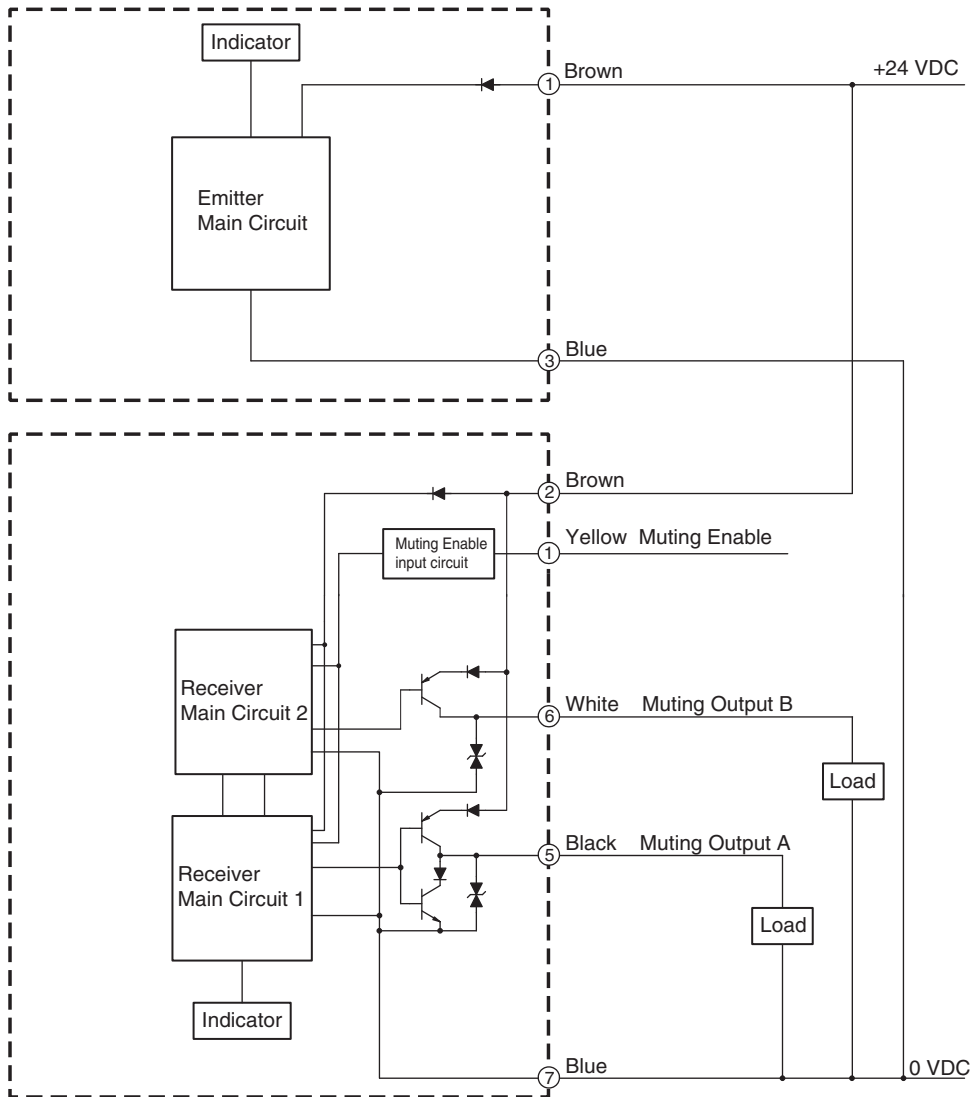

# Dimensions

## Mounted with Standard Adjustable Brackets (F39-LGA) Backside Mounting

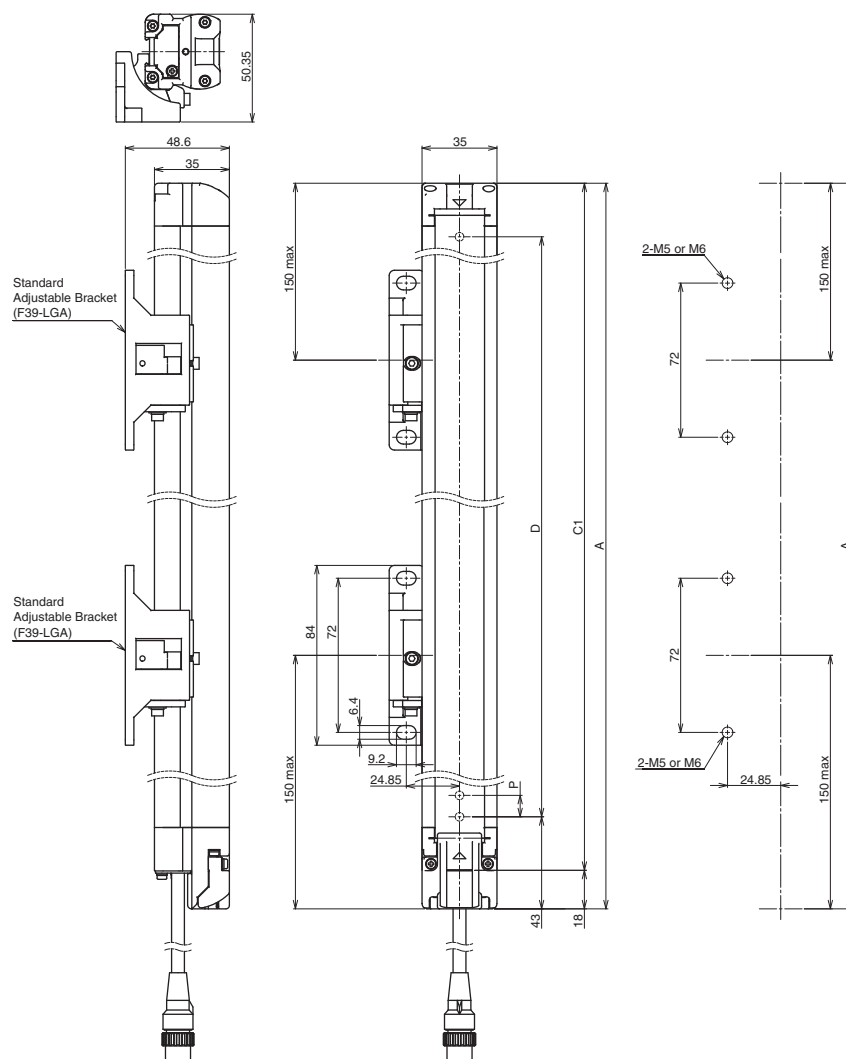

< Screw: M5 or M6 >

Model	F3W-MA0100P	F3W-MA0300P
Dimension A	208	448
Dimension C1	190	430
Dimension D	140	380
Dimension P	20	20
Number of Standard Adjustable Brackets *1	2 *2	2

\*1. The number of brackets required to mount either one of emitter and receiver.

\*2. Mounting an emitter or receiver with one bracket is possible. In this case, locate this bracket at half the Dimension A (or at the center of the sensor length).

## Side Mounting

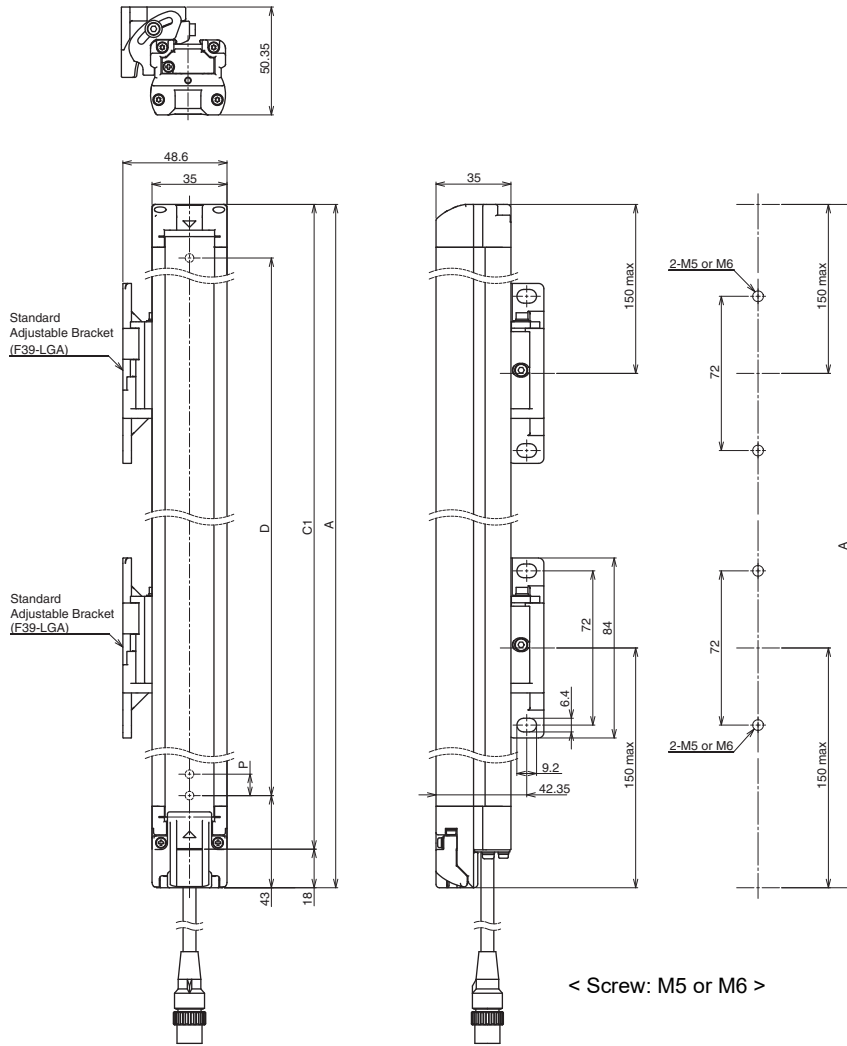

Model	F3W-MA0100P	F3W-MA0300P
Dimension A	208	448
Dimension C1	190	430
Dimension D	140	380
Dimension P	20	20
Number of Standard Adjustable Brackets *1	2 *2	2

- \*1. The number of brackets required to mount either one of emitter and receiver.
- \*2. Mounting an emitter or receiver with one bracket is possible. In this case, locate this bracket at half the Dimension A (or at the center of the sensor length).

### Standard Adjustable Bracket (F39-LGA, sold separately)

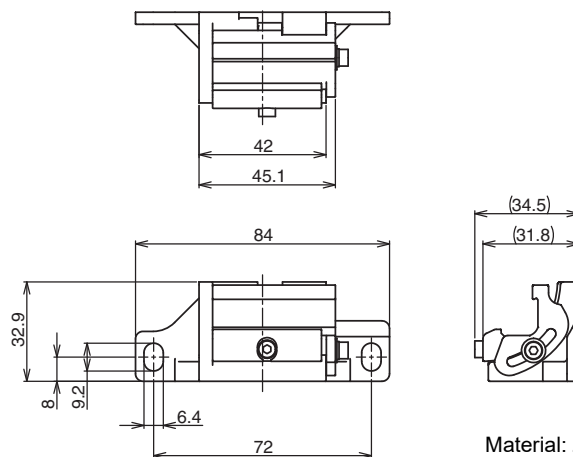

Material: Zinc alloy, Fluorine-containing

### Mounted with Standard Fixed Brackets (F39-LGF) Backside Mounting

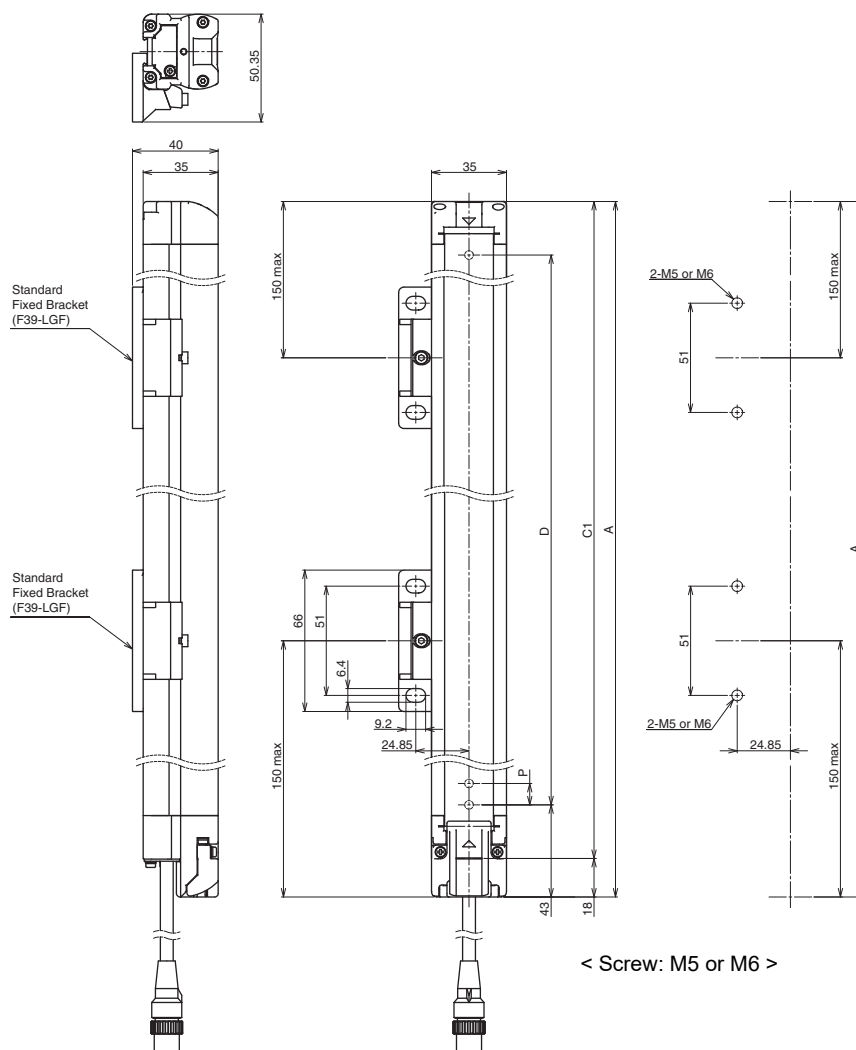

Model	F3W-MA0100P	F3W-MA0300P
Dimension A	208	448
Dimension C1	190	430
Dimension D	140	380
Dimension P	20	20
Number of Standard Fixed Brackets *1	2 *2	2

\*1. The number of brackets required to mount either one of emitter and receiver.  
 \*2. Mounting an emitter or receiver with one bracket is possible. In this case, locate this bracket at half the Dimension A (or at the center of the sensor length).

## Side Mounting

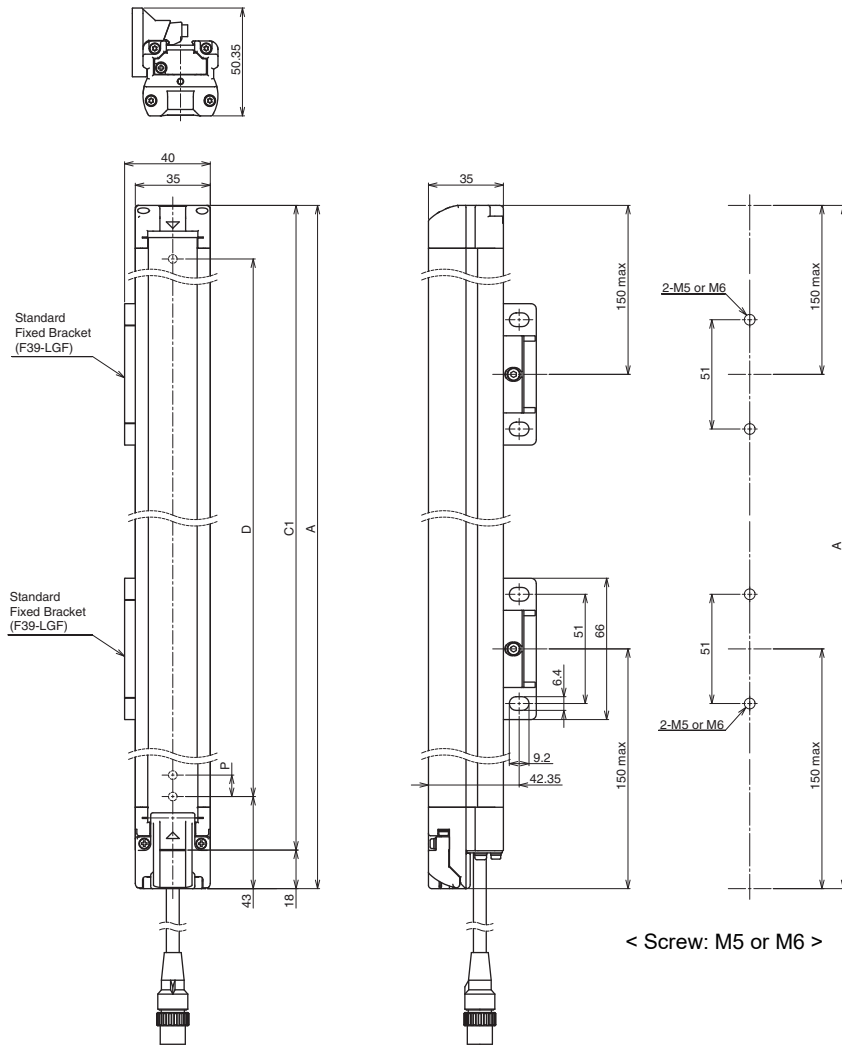

Model	F3W-MA0100P	F3W-MA0300P
Dimension A	208	448
Dimension C1	190	430
Dimension D	140	380
Dimension P	20	20
Number of Standard Fixed Brackets *1	2 *2	2

- \*1. The number of brackets required to mount either one of emitter and receiver.
- \*2. Mounting an emitter or receiver with one bracket is possible. In this case, locate this bracket at half the Dimension A (or at the center of the sensor length).

### Standard Fixed Bracket (F39-LGF, sold separately)

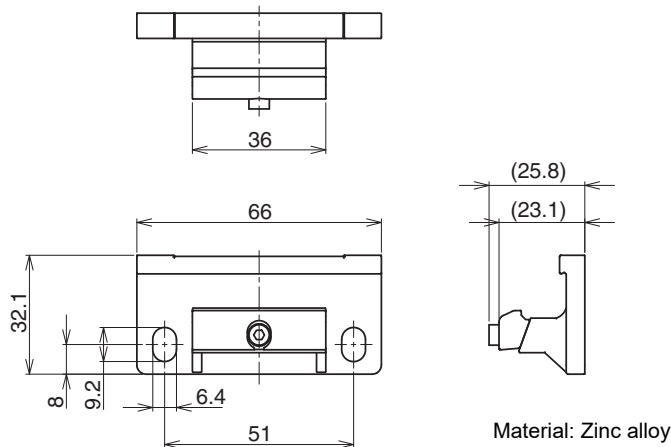

Mounted with F3W-MA Bracket (F39-LGMA□) and Standard Adjustable Bracket (F39-LGA) on F3SG-RA

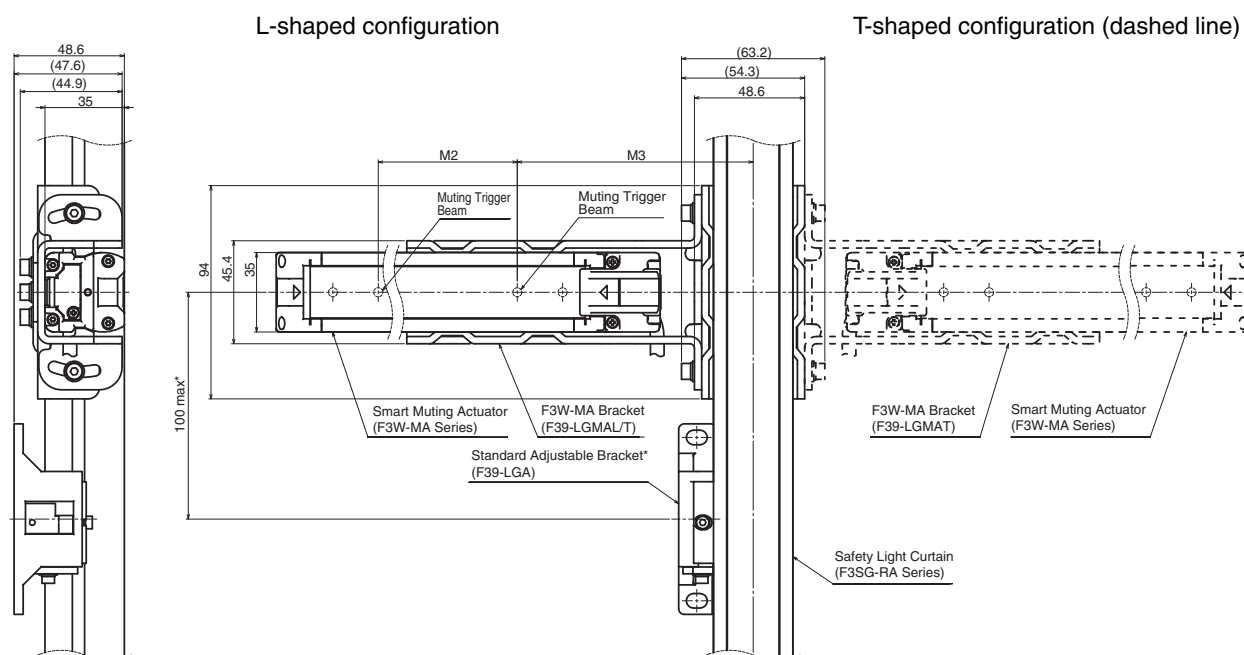

**Note:** When mounting an F3W-MA0300P in the L-shaped configuration, the shock resistance becomes as follows.

Shock resistance: 50 m/s<sup>2</sup>, 1000 shocks for all 3 axes

For mounting an F3W-MA0300P under a shock environment exceeding this, the F3W-MA Bracket cannot be used. Use a Standard Adjustable Bracket (F39-LGA).

\* The distance between the centers of the F3W-MA and the Standard Adjustable Bracket (F39-LGA) must be 100 mm or less. When the distance is longer than 100 mm, add an extra Standard Adjustable Bracket for reinforcement.

Model	F3W-MA0100P	F3W-MA0300P
Dimension M2	100	300
Dimension M3	104	124

**Accessories**

**Single-Ended Cable for Emitter (F39-JG□A-L, sold separately)**

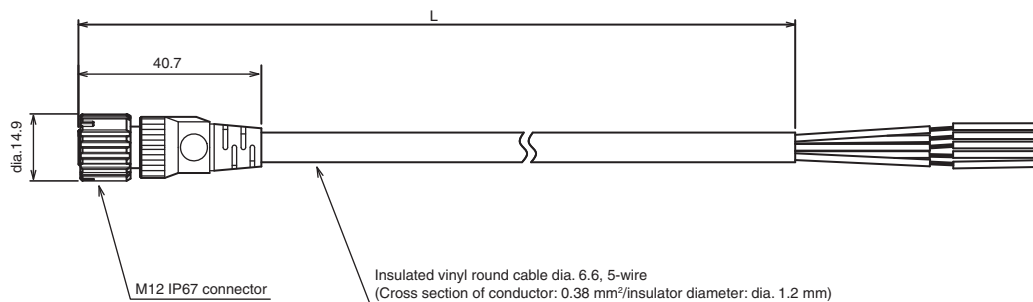

**Single-Ended Cable for Receiver (F39-JG□A-D, sold separately)**

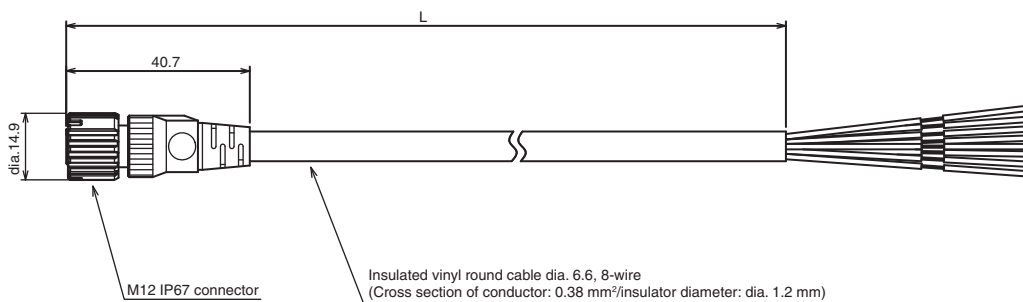

Emitter cable (Gray)	Receiver cable (Black)	L (m)
F39-JG3A-L	F39-JG3A-D	3
F39-JG7A-L	F39-JG7A-D	7
F39-JG10A-L	F39-JG10A-D	10
F39-JG15A-L	F39-JG15A-D	15
F39-JG20A-L	F39-JG20A-D	20

# F3W-MA

## Double-Ended Cable for Emitter: Cable for extension (F39-JG□B-L, sold separately)

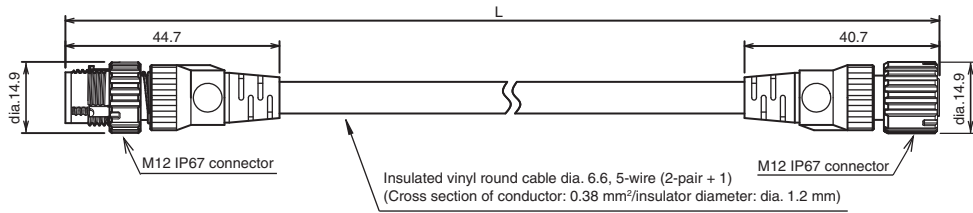

## Double-Ended Cable for Receiver: Cable for extension (F39-JG□B-D, sold separately)

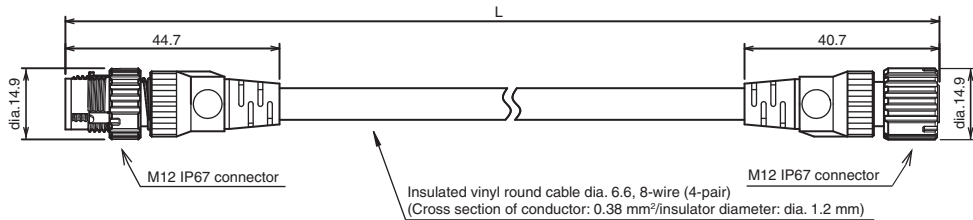

Emitter cable (Gray)	Receiver cable (Black)	L (m)
F39-JGR5B-L	F39-JGR15B-D	0.5
F39-JG1B-L	F39-JG1B-D	1
F39-JG3B-L	F39-JG3B-D	3
F39-JG5B-L	F39-JG5B-D	5
F39-JG7B-L	F39-JG7B-D	7
F39-JG10B-L	F39-JG10B-D	10
F39-JG15B-L	F39-JG15B-D	15
F39-JG20B-L	F39-JG20B-D	20

## 4-Joint Plug/Socket Connector for Emitter (F39-GCN4-L, sold separately)

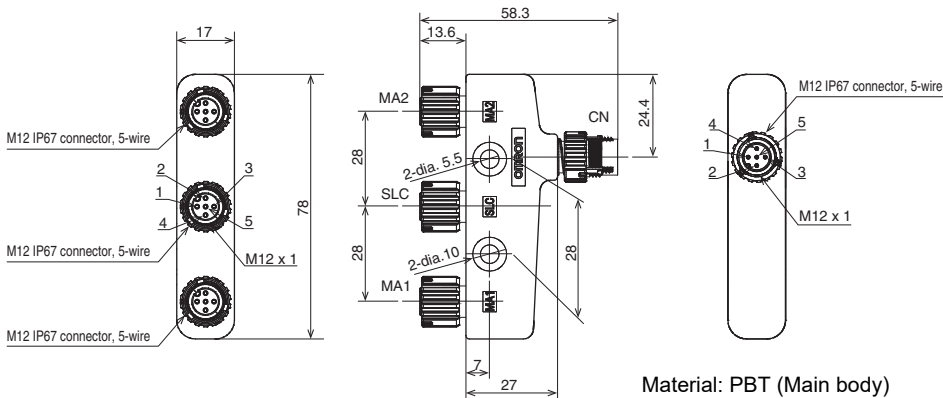

## 4-Joint Plug/Socket Connector for Receiver (F39-GCN4-D, sold separately)

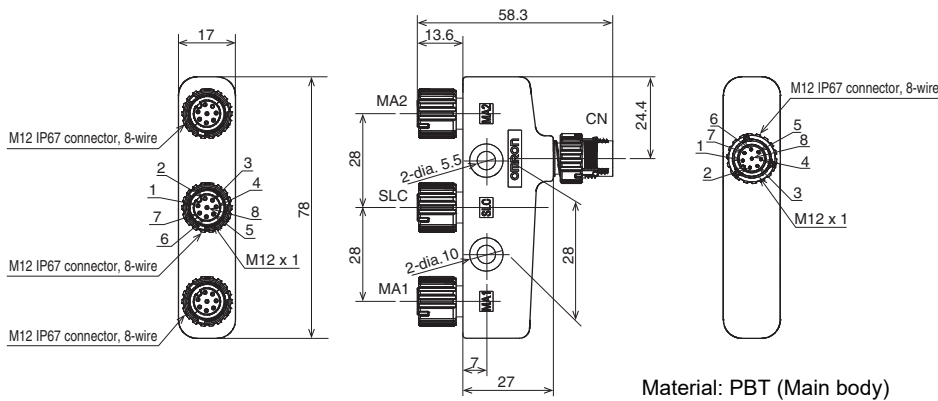

## Related Manuals

ManNo.	Model	Manual name
Z355	F3W-MA	Smart Muting Actuator F3W-MA Series User's Manual





# Terms and Conditions Agreement

## **Read and understand this catalog.**

Please read and understand this catalog before purchasing the products. Please consult your OMRON representative if you have any questions or comments.

## **Warranties.**

- (a) Exclusive Warranty. Omron's exclusive warranty is that the Products will be free from defects in materials and workmanship for a period of twelve months from the date of sale by Omron (or such other period expressed in writing by Omron). Omron disclaims all other warranties, express or implied.
- (b) Limitations. OMRON MAKES NO WARRANTY OR REPRESENTATION, EXPRESS OR IMPLIED, ABOUT NON-INFRINGEMENT, MERCHANTABILITY OR FITNESS FOR A PARTICULAR PURPOSE OF THE PRODUCTS. BUYER ACKNOWLEDGES THAT IT ALONE HAS DETERMINED THAT THE PRODUCTS WILL SUITABLY MEET THE REQUIREMENTS OF THEIR INTENDED USE.

Omron further disclaims all warranties and responsibility of any type for claims or expenses based on infringement by the Products or otherwise of any intellectual property right. (c) Buyer Remedy. Omron's sole obligation hereunder shall be, at Omron's election, to (i) replace (in the form originally shipped with Buyer responsible for labor charges for removal or replacement thereof) the non-complying Product, (ii) repair the non-complying Product, or (iii) repay or credit Buyer an amount equal to the purchase price of the non-complying Product; provided that in no event shall Omron be responsible for warranty, repair, indemnity or any other claims or expenses regarding the Products unless Omron's analysis confirms that the Products were properly handled, stored, installed and maintained and not subject to contamination, abuse, misuse or inappropriate modification. Return of any Products by Buyer must be approved in writing by Omron before shipment. Omron Companies shall not be liable for the suitability or unsuitability or the results from the use of Products in combination with any electrical or electronic components, circuits, system assemblies or any other materials or substances or environments. Any advice, recommendations or information given orally or in writing, are not to be construed as an amendment or addition to the above warranty.

See <http://www.omron.com/global/> or contact your Omron representative for published information.

## **Limitation on Liability; Etc.**

OMRON COMPANIES SHALL NOT BE LIABLE FOR SPECIAL, INDIRECT, INCIDENTAL, OR CONSEQUENTIAL DAMAGES, LOSS OF PROFITS OR PRODUCTION OR COMMERCIAL LOSS IN ANY WAY CONNECTED WITH THE PRODUCTS, WHETHER SUCH CLAIM IS BASED IN CONTRACT, WARRANTY, NEGLIGENCE OR STRICT LIABILITY.

Further, in no event shall liability of Omron Companies exceed the individual price of the Product on which liability is asserted.

## **Suitability of Use.**

Omron Companies shall not be responsible for conformity with any standards, codes or regulations which apply to the combination of the Product in the Buyer's application or use of the Product. At Buyer's request, Omron will provide applicable third party certification documents identifying ratings and limitations of use which apply to the Product. This information by itself is not sufficient for a complete determination of the suitability of the Product in combination with the end product, machine, system, or other application or use. Buyer shall be solely responsible for determining appropriateness of the particular Product with respect to Buyer's application, product or system. Buyer shall take application responsibility in all cases.

NEVER USE THE PRODUCT FOR AN APPLICATION INVOLVING SERIOUS RISK TO LIFE OR PROPERTY OR IN LARGE QUANTITIES WITHOUT ENSURING THAT THE SYSTEM AS A WHOLE HAS BEEN DESIGNED TO ADDRESS THE RISKS, AND THAT THE OMRON PRODUCT(S) IS PROPERLY RATED AND INSTALLED FOR THE INTENDED USE WITHIN THE OVERALL EQUIPMENT OR SYSTEM.

## **Programmable Products.**

Omron Companies shall not be responsible for the user's programming of a programmable Product, or any consequence thereof.

## **Performance Data.**

Data presented in Omron Company websites, catalogs and other materials is provided as a guide for the user in determining suitability and does not constitute a warranty. It may represent the result of Omron's test conditions, and the user must correlate it to actual application requirements. Actual performance is subject to the Omron's Warranty and Limitations of Liability.

## **Change in Specifications.**

Product specifications and accessories may be changed at any time based on improvements and other reasons. It is our practice to change part numbers when published ratings or features are changed, or when significant construction changes are made. However, some specifications of the Product may be changed without any notice. When in doubt, special part numbers may be assigned to fix or establish key specifications for your application. Please consult with your Omron's representative at any time to confirm actual specifications of purchased Product.

## **Errors and Omissions.**

Information presented by Omron Companies has been checked and is believed to be accurate; however, no responsibility is assumed for clerical, typographical or proofreading errors or omissions.

**Note: Do not use this document to operate the Unit.**

**OMRON Corporation Industrial Automation Company**

**Kyoto, JAPAN**

**Contact : [www.ia.omron.com](http://www.ia.omron.com)**

**Regional Headquarters**

**OMRON EUROPE B.V.**

Wegalaan 67-69, 2132 JD Hoofddorp  
The Netherlands

Tel: (31) 2356-81-300 Fax: (31) 2356-81-388

**OMRON ASIA PACIFIC PTE. LTD.**

438B Alexandra Road, #08-01/02 Alexandra  
Technopark, Singapore 119968

Tel: (65) 6835-3011 Fax: (65) 6835-3011

**OMRON ELECTRONICS LLC**

2895 Greenspoint Parkway, Suite 200  
Hoffman Estates, IL 60169 U.S.A.

Tel: (1) 847-843-7900 Fax: (1) 847-843-7787

**OMRON (CHINA) CO., LTD.**

Room 2211, Bank of China Tower,  
200 Yin Cheng Zhong Road,  
PuDong New Area, Shanghai, 200120, China

Tel: (86) 21-6023-0333 Fax: (86) 21-5037-2388

**Authorized Distributor:**

©OMRON Corporation 2014-2024 All Rights Reserved.  
In the interest of product improvement,  
specifications are subject to change without notice.

**CSM\_12\_7**

**Cat. No. F094-E1-13** 0524 (1214)