

CONNECTOR PART NUMBER BUILD
SAMPLE PART NUMBER: VSF-04-10-50-00

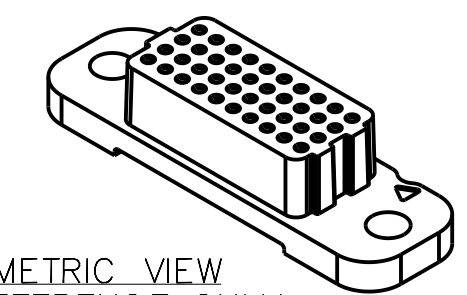

ISOMETRIC VIEW
FOR REFERENCE ONLY
(PART NUMBER VSF-04-10-50-00 SHOWN)

VSF-XX-XX-XX-XX-XX

HARDWARE OPTIONS		
BLANK	NO HARDWARE	2
G	GUIDE SOCKET	3
G1	GUIDE SOCKET	4
J	TURNING JACKSCREW	3
J1	TURNING JACKSCREW	4
L	LOCKING SCREW	3
L1	LOCKING SCREW	4
N	FIXED JACKNUT	3
N1	FIXED JACKNUT	4

TERMINATION	
00	PRESS-FIT
01	PASTE-IN-HOLE (PIH)
02	PLATED-THRU-HOLE (PTH) .078" LENGTH
03	PLATED-THRU-HOLE (PTH) .109" LENGTH
04	PLATED-THRU-HOLE (PTH) .140" LENGTH
05	PLATED-THRU-HOLE (PTH) .156" LENGTH
06	PLATED-THRU-HOLE (PTH) .172" LENGTH
10	SURFACE MOUNT (SMT) NON-RoHS COMPLIANT
11	SURFACE MOUNT (SMT) RoHS COMPLIANT

CONTACT PLATING	
50	50µIN Au

COLUMNS	
10	10 COLUMNS
20	20 COLUMNS
30	30 COLUMNS
40	40 COLUMNS
50	50 COLUMNS

ROWS	
04	4 ROWS
05	5 ROWS
06	6 ROWS
08	8 ROWS
10	10 ROWS

MATERIAL AND FINISHES		
SOCKET CONTACTS	MATERIAL	BeCu PER ASTM B194
	FINISH SOCKET END	50µIN MIN LOCALIZED Au PER ASTM B488 TYPE II, CODE C OVER 50µIN MIN Ni PER ASTM B689 TYPE 1
SOCKET CONTACTS	FINISH TERMINATION END	PIH & PTH: 10µIN MIN LOCALIZED Au FLASH PER ASTM B488 TYPE I, CODE A OR C OVER 50µIN MIN Ni PER ASTM B689 TYPE 1 PRESS-FIT: 50µIN MIN LOCALIZED Au PER ASTM B488 TYPE II, CODE C OVER 50µIN MIN Ni PER ASTM B689 TYPE 1 SMT NON-RoHS: 10µIN MIN LOCALIZED Au FLASH PER ASTM B488 TYPE I, CODE A OR C OVER 50µIN MIN Ni PER ASTM B689 TYPE 1. TIN DIPPED WITH Sn63Pb37 SOLDER. SMT RoHS: 10µIN MIN LOCALIZED Au FLASH PER ASTM B488 TYPE I, CODE A OR C OVER 50µIN MIN Ni PER ASTM B689 TYPE 1. TIN DIPPED WITH 42Sn/57.6Bi/0.4Ag SOLDER.
	MOLDED INSULATORS	MATERIAL
EMBEDMENT	MATERIAL	FREY ENG. CO. INSULATING COMPOUND CF3003-80 OR EQUIVALENT
HARDWARE	MATERIAL	STAINLESS STEEL PER ASTM A484/A484M, ASTM A582/A582M, OR ASTM A320
	FINISH	PASSIVATED PER SAE AMS-2700
WASHERS	MATERIAL	STAINLESS STEEL PER SAE NASM35333 (ASTM A240)
	FINISH	PASSIVATED PER NASM35333 (SAE AMS-2700)

PERFORMANCE	
CONTACT RATING	2 AMPERES MAXIMUM, SEE AIRBORN PTB66 FOR MORE INFO
OPERATING TEMPERATURE	-55° C TO 125° C, SEE AIRBORN PTB66 FOR MORE INFO
CONTACT ENGAGEMENT FORCE	6.0oz MAX*
CONTACT SEPARATION FORCE	0.5oz MIN*
CONNECTOR MATING FORCE	10oz X (# OF CONTACTS) MAX TESTED PER MIL-DTL-83513
CONNECTOR UNMATING FORCE	10oz X (# OF CONTACTS) MAX TESTED PER MIL-DTL-83513
DWV (SEA LEVEL)	600V, RMS, 60Hz, SEE AIRBORN PTB61 FOR MORE INFO
RECOMMENDED MAX OPERATING VOLTAGE	200V, RMS, 60Hz, SEE AIRBORN PTB61 FOR MORE INFO
INSULATION RESISTANCE	5,000 MEGAOHMS MINIMUM @ 500 VDC TESTED PER MIL-DTL-83513
DURABILITY	2,500 CONNECTOR MATING CYCLES, EXCEEDS MIL-DTL-83513
SINUSOIDAL VIBRATION	20 g, TESTED PER MIL-DTL-83513
SHOCK	50 g, TESTED PER MIL-DTL-83513
OUTGASSING	MAX TML OF 1% AND MAX CVCM OF .1% PER MIL-DTL-83513

*FORCES TESTED ON SOCKET ONLY. MAX PIN SIZE USED FOR CONTACT ENGAGEMENT FORCE AND MIN PIN SIZE USED FOR CONTACT SEPARATION FORCE.

NOTES:

- SEE AIRBORN SPEC ESL5001 FOR ADDITIONAL APPLICATION INFORMATION.
- SEE SHEET 8 FOR REPLACEMENT HARDWARE KITS.
- USE FOR UP TO .125 PCB THICKNESS.
- USE FOR .125 TO .250 PCB THICKNESS.
- NO HARDWARE SUPPLIED WITH BLANK HARDWARE OPTION CONNECTORS.
- ONLY AVAILABLE FOR 4 ROW CONNECTORS.
- PACKAGING: PARTS SUPPLIED IN THERMOFORMED TRAYS, HARDWARE SUPPLIED UNINSTALLED.
- MATES WITH CONNECTOR SERIES: VSM, VSRAM, VSX (MALE), VRD (MALE), VRW (MALE).

MATERIAL: SEE NOTES	UNLESS OTHERWISE SPECIFIED, TOLERANCES ARE: Decimals: .XX ± .010 Concentricity: .002 T.I.R. Decimals: .XXX ± .005 Angles: ± 3° Decimals: .XXXX ± .0005 Radius: Parts are to be symmetrical about centerline within ± .002 Surfaces to be flat, perpendicular parallel within .002 T.I.R. Dimensions are in inches/DQ NOT SCALE PRINT Surface finish to be 32/ or better	AirBorn Little Falls, Minnesota 56345	Cage Code 10400
HEAT TREAT: Per Spec.: Certification required: NO	APPLICATION: verSI SERIES	DR. TJW 100517 T I T L E verSI SERIES VERTICAL FEMALE NON-RUGGEDIZED PRODUCT DRAWING	SIZE c
FINISH: SEE NOTES Per Spec.: Certification required: NO	D SEE ECN REV DESCRIPTION	RCS W67900 072023 RCS 072023 DR. BY DATE ECO NO. APPD. BY REL. TJW 100517	DR. TJW 100517 RCS 100517 APPD. JPS 100517
MAKE FROM: N/A NEXT ASSY: N/A	► = CRITICAL CHARACTERISTIC ● = MAJOR CHARACTERISTIC	THIRD ANGLE PROJECTION	DWG # VSF-XX-XX-XX-XX-XX REV. D SHEET 1/8



CONNECTOR DIMENSIONS (BLANK HARDWARE OPTION SHOWN)

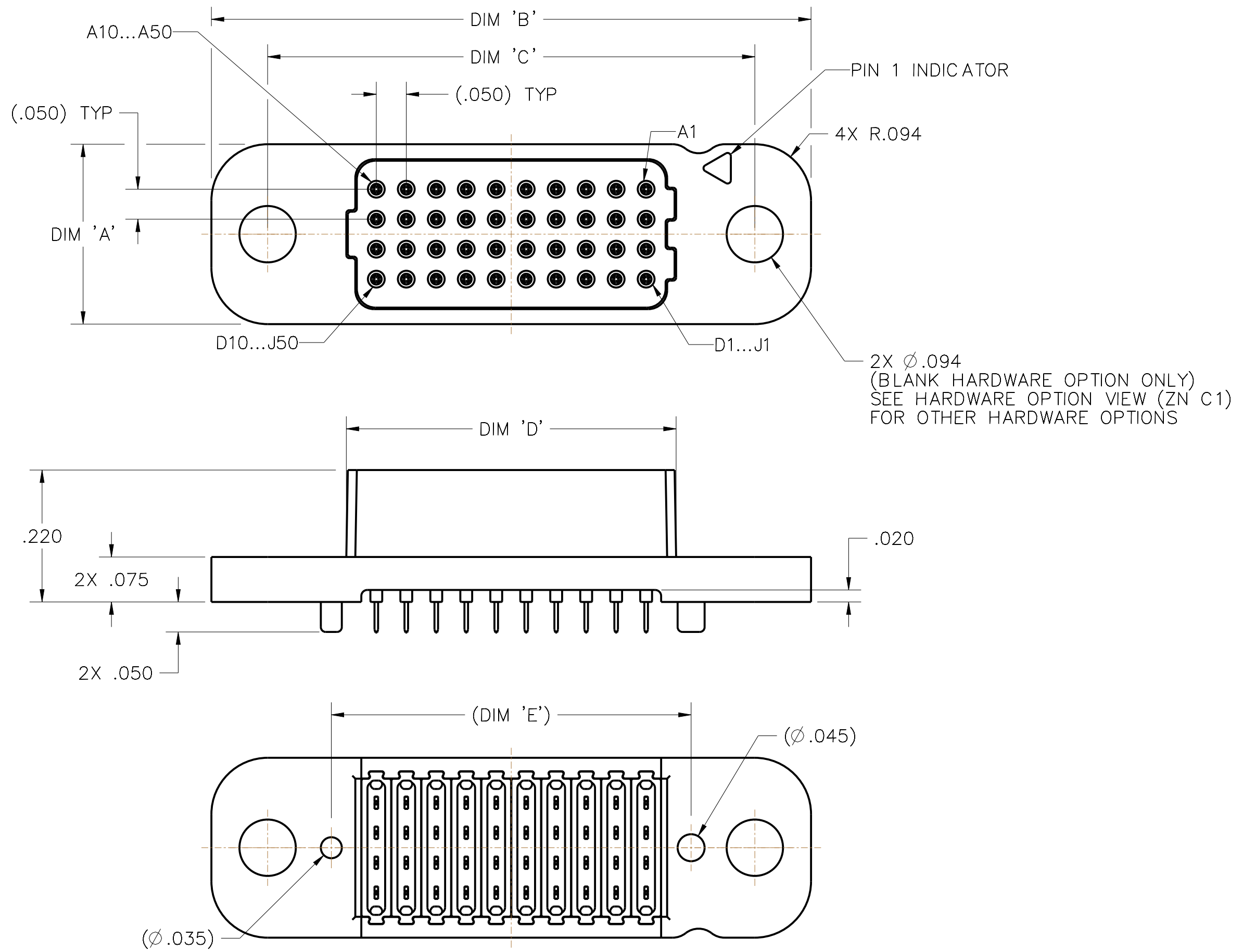

ROWS	DIM 'A'
04	.300
05	.350
06	.400
08	.500
10	.600

COLUMNS	DIM 'B'	DIM 'C'	DIM 'D'	DIM 'E'
10	1.000	.813	.550	.600
20	1.500	1.313	1.050	1.100
30	2.000	1.813	1.550	1.600
40	2.500	2.313	2.050	2.100
50	3.000	2.813	2.550	2.600

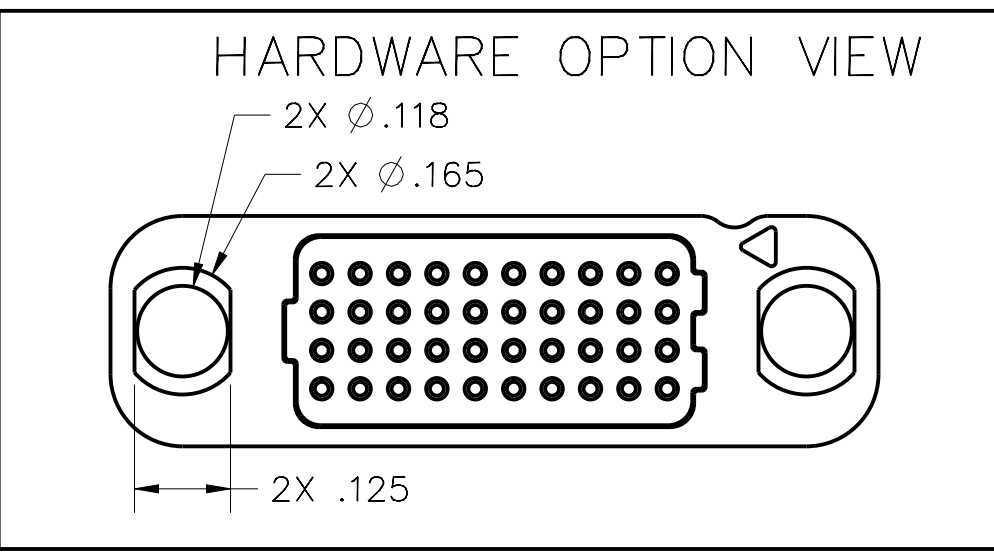
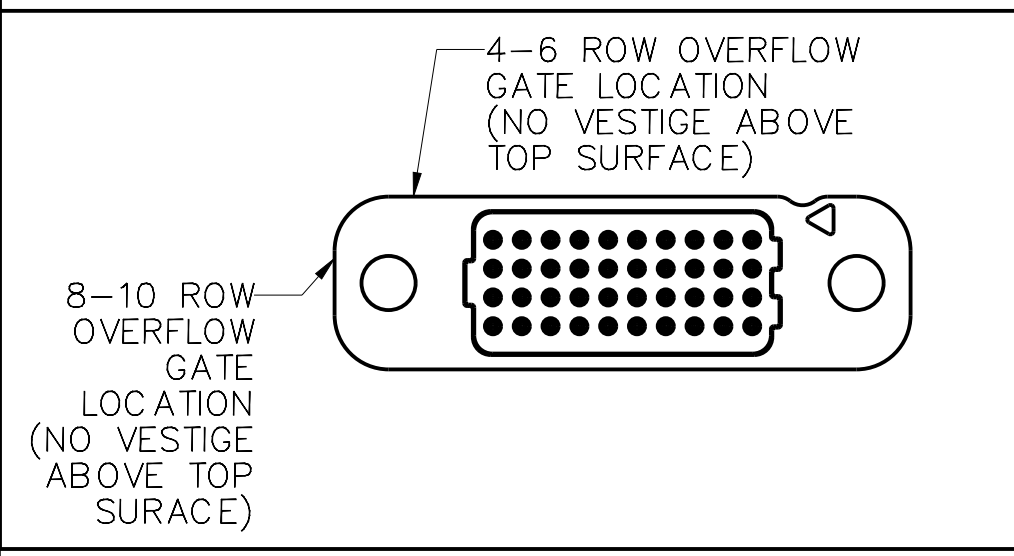

<p>Little Falls, Minnesota 56345</p>	verSI SERIES VERTICAL FEMALE NON-RUGGEDIZED PRODUCT DRAWING	DRAWING STATE: <i>Released</i> <input checked="" type="checkbox"/> RELEASED This drawing is not authorized for production unless it is released	SIZE
		DWG # VSF-XX-XX-XX-XX-XX REV. D	SHEET 2 / 8 C

FORMAT: CFINTPRG.FRM A.7

4

3

2

1

D

C

B

A

PART MARKING
(10 & 20 COLUMNS)

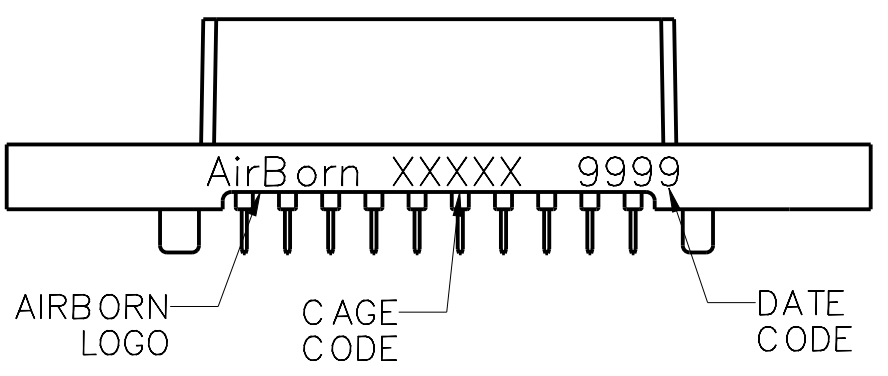
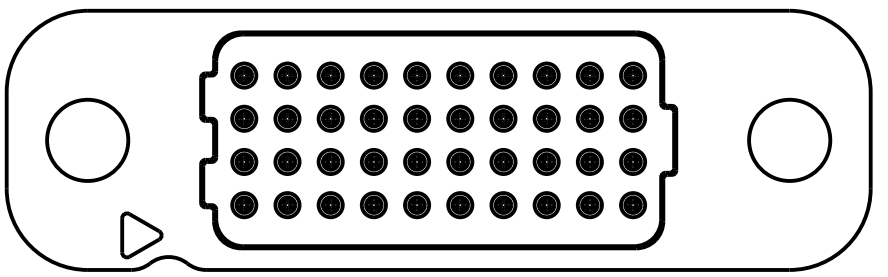
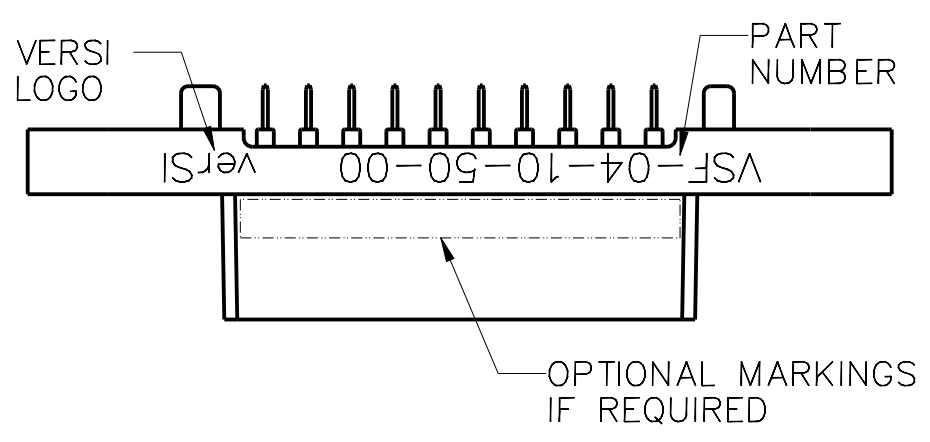

(VSF-04-10-XX-XX-XX SHOWN)

PART MARKING
(30, 40, & 50 COLUMNS)

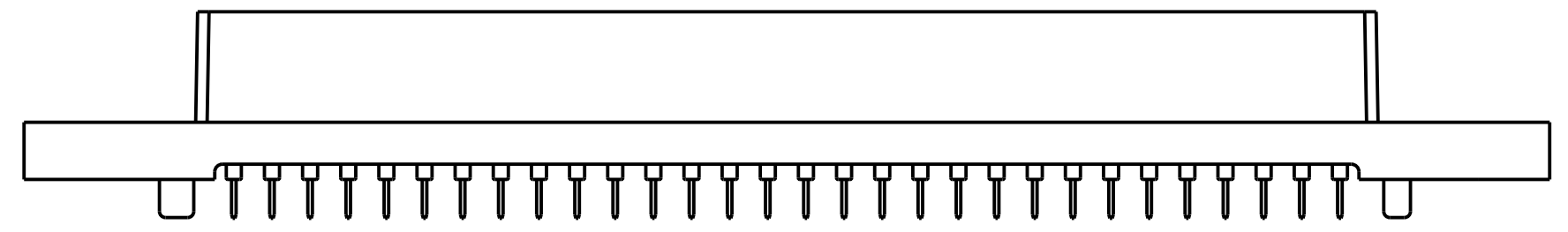
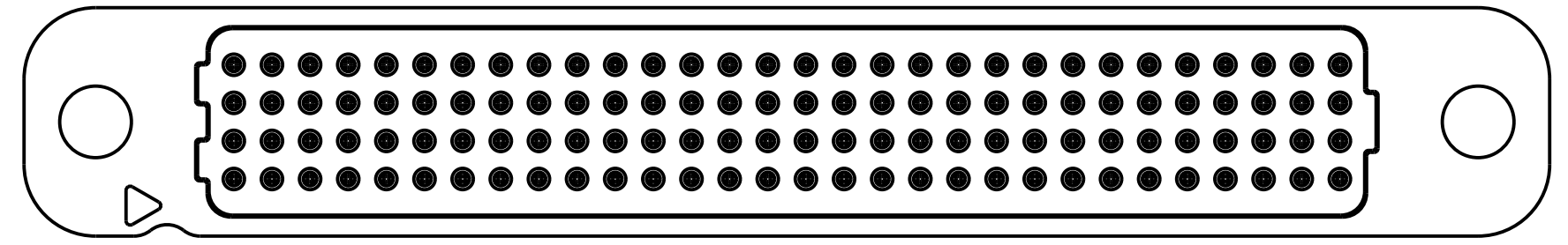
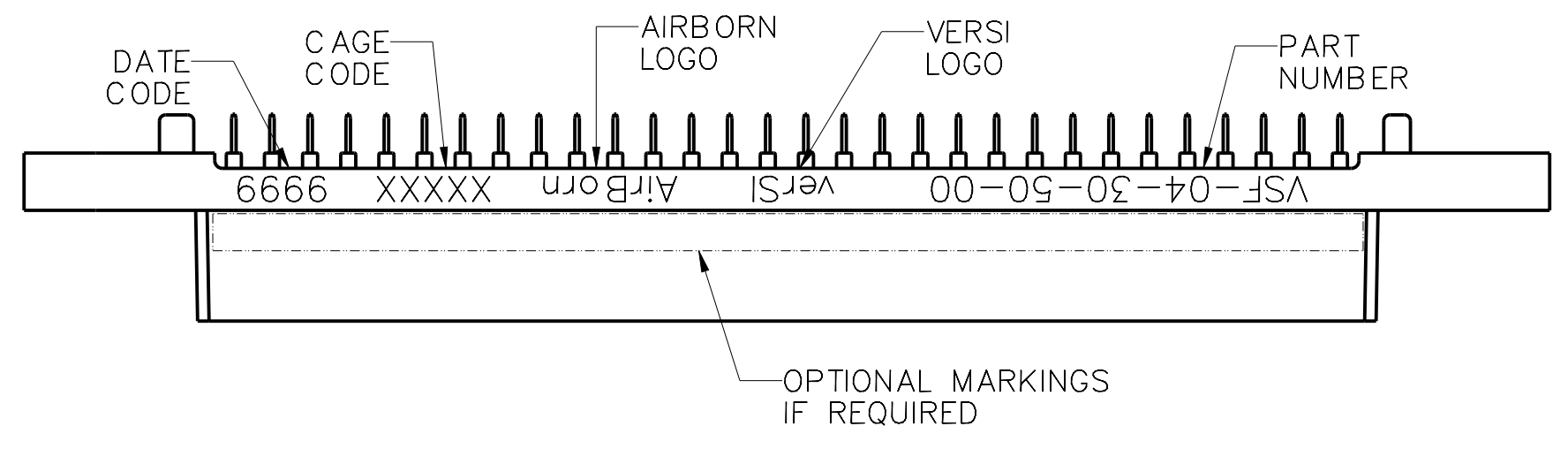

(VSF-04-30-XX-XX-XX SHOWN)

FORMAT: CFMTPRO.FRM A.7

TERMINATION DIMENSIONS

TERMINATION TYPE 00
PRESS-FIT

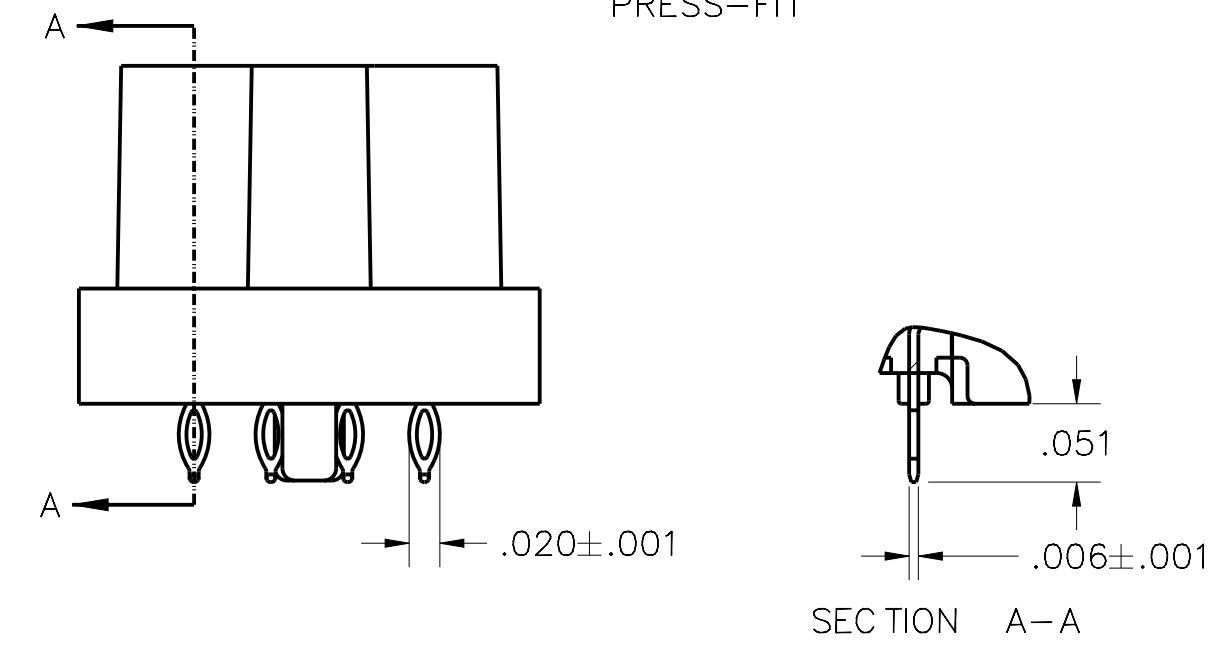

TERMINATION TYPE 01
PIH

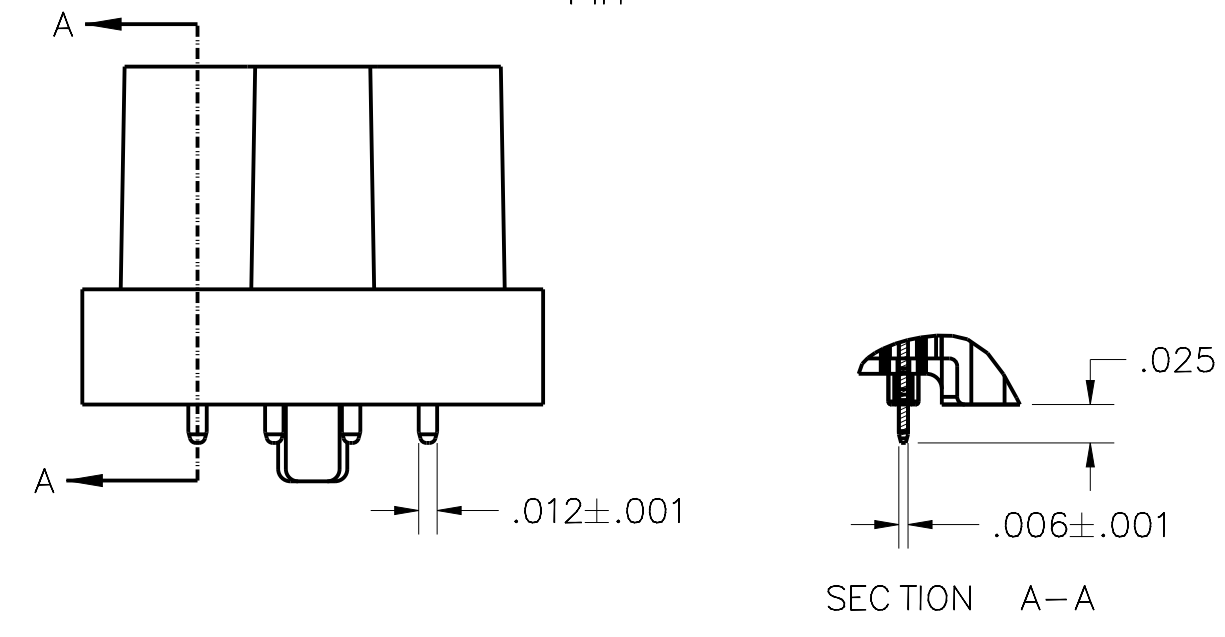

TERMINATION TYPE 02
PTH .078" LENGTH

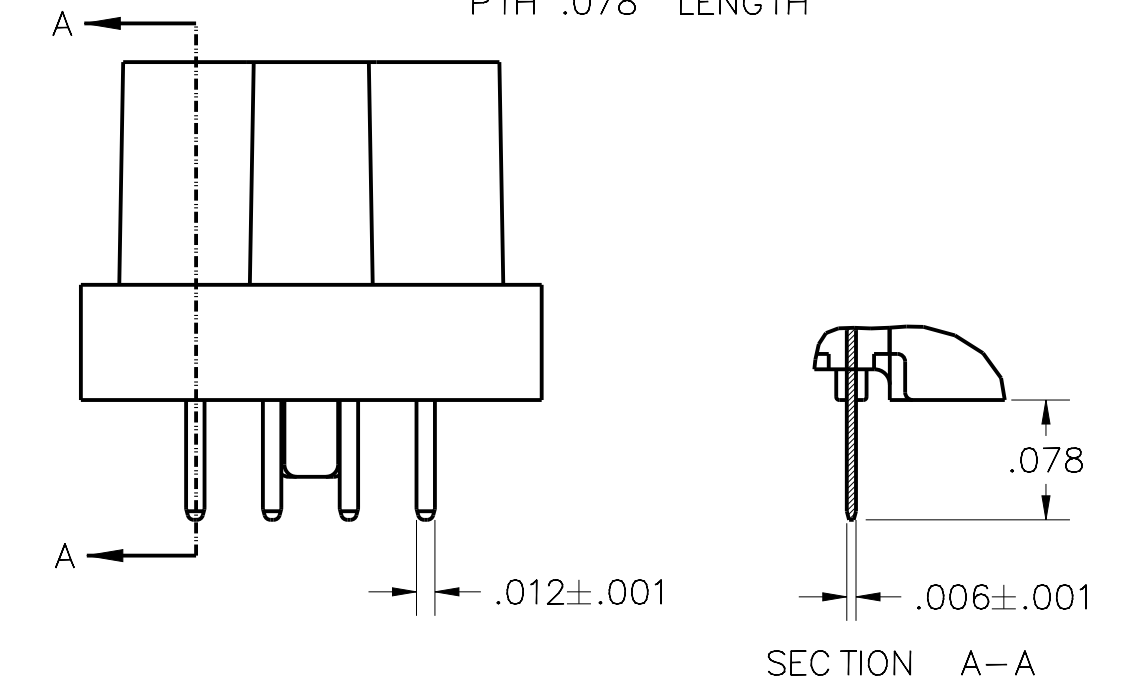

TERMINATION TYPE 03
PTH .109" LENGTH

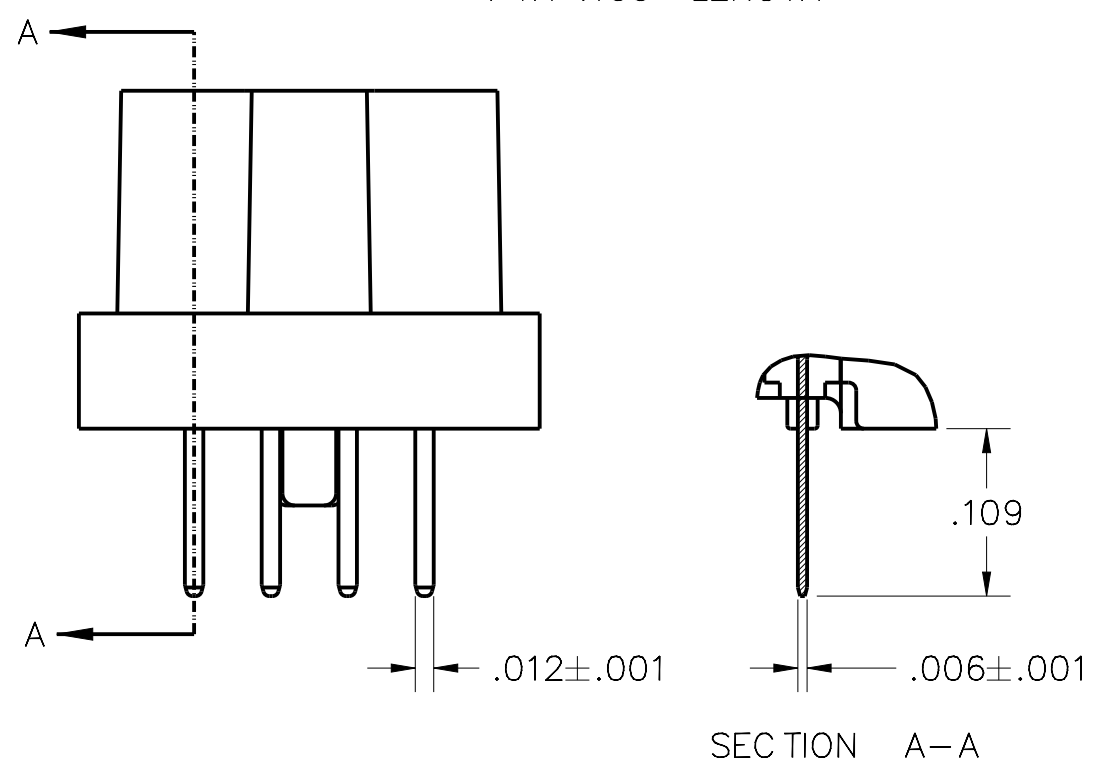

TERMINATION TYPE 04
PTH .140" LENGTH

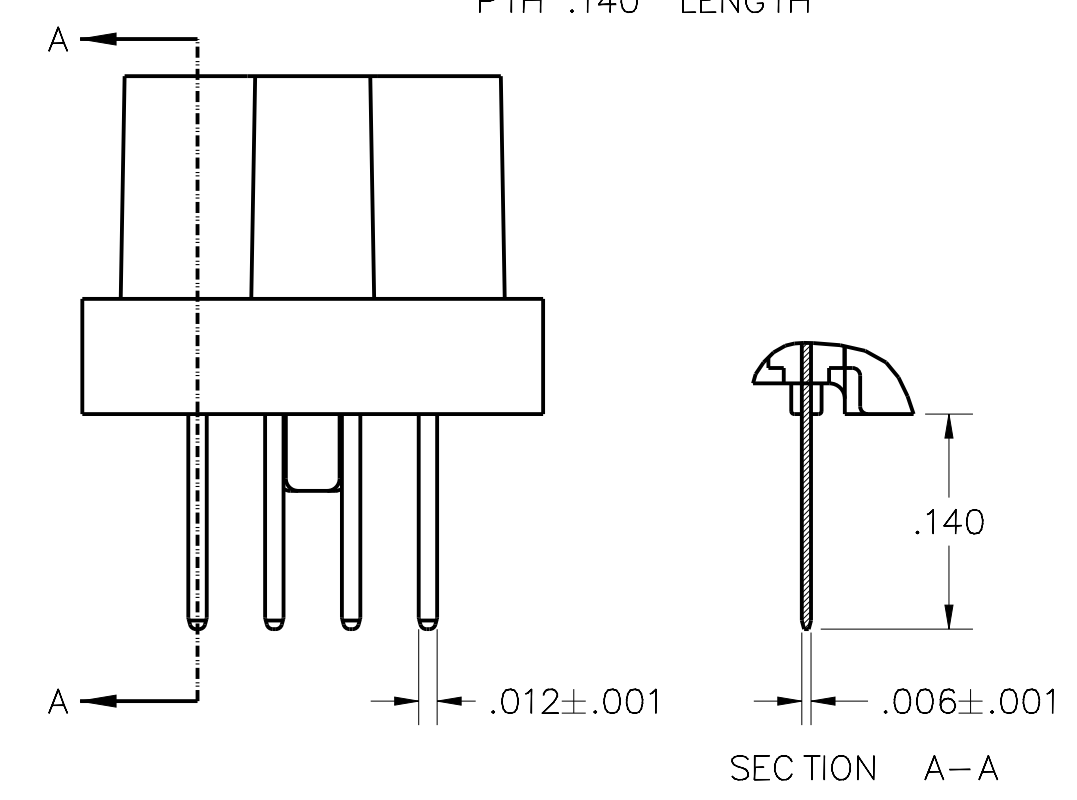

TERMINATION TYPE 05
PTH .156" LENGTH

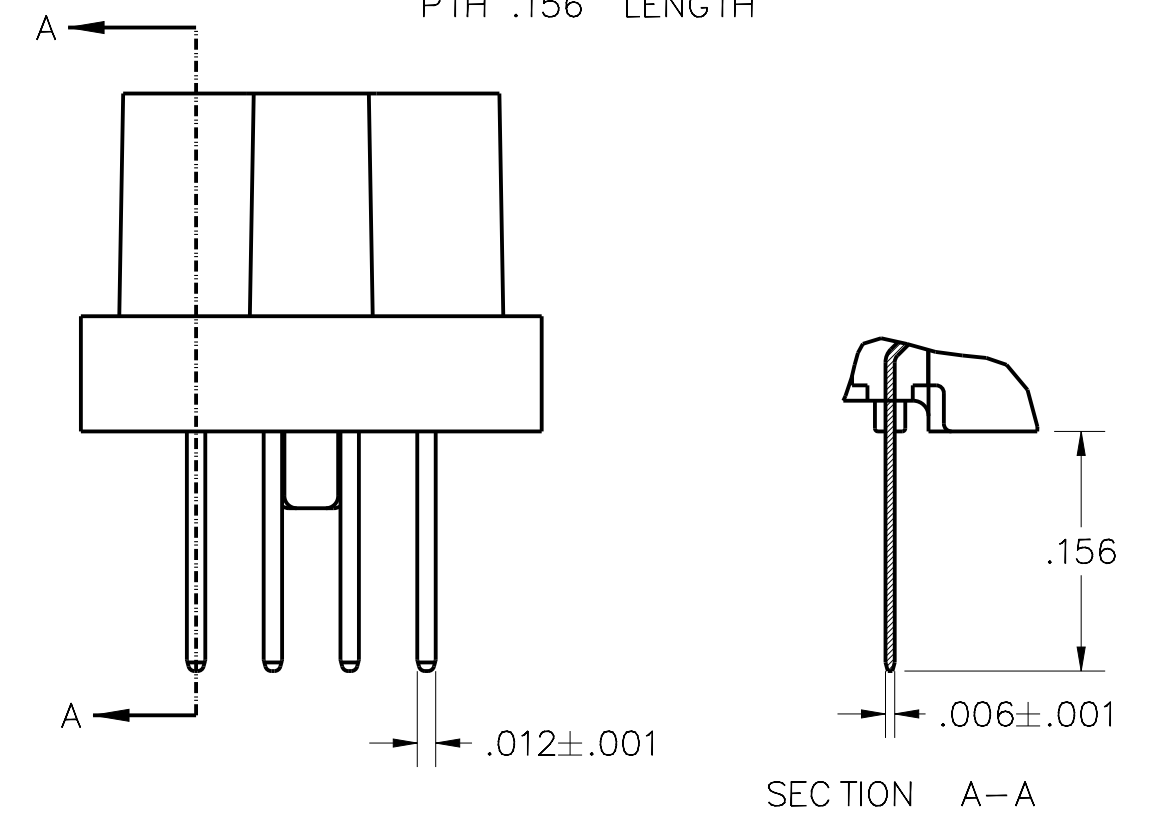

TERMINATION TYPE 06
PTH .172" LENGTH

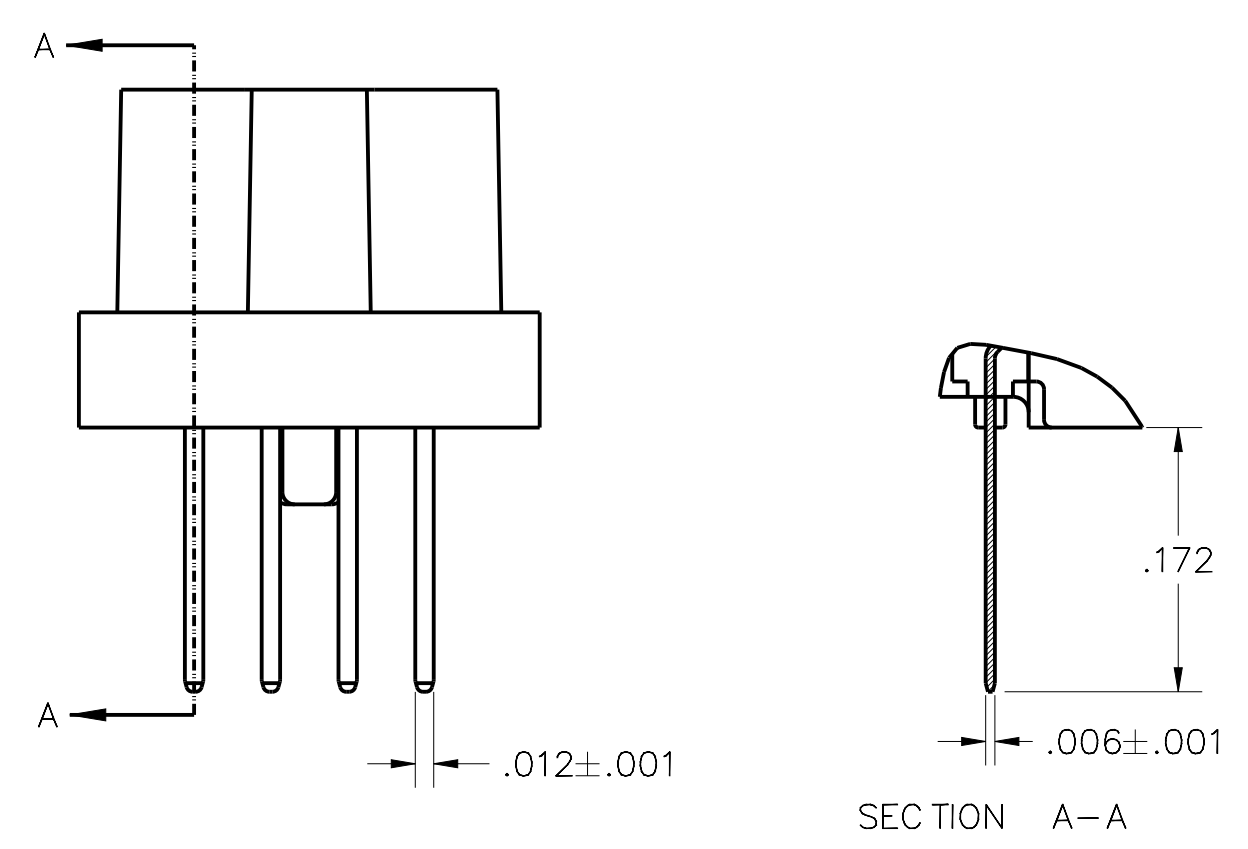

TERMINATION TYPE 10 & 11
SMT

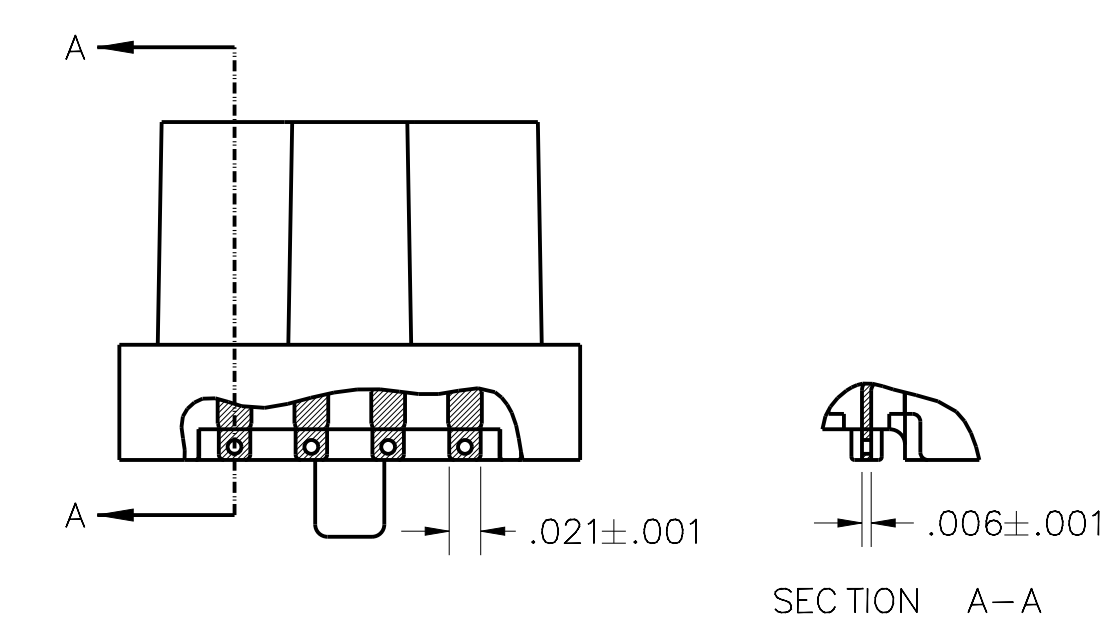

RECOMMENDED PCB THICKNESS FOR EACH TERMINATION TYPE	
TERMINATION	PCB THICKNESS
-00	.062" MIN
-01	.055" MIN
-02	.068" MAX
-03	.099" MAX
-04	.130" MAX
-05	.146" MAX
-06	.162" MAX

4

3

2

1

FORMAT: CFINTPRG.FRM A.7

D

C

B

A

SIZE
C

PCB MOUNTING INSTRUCTIONS
 (BLANK HARDWARE OPTION SHOWN)

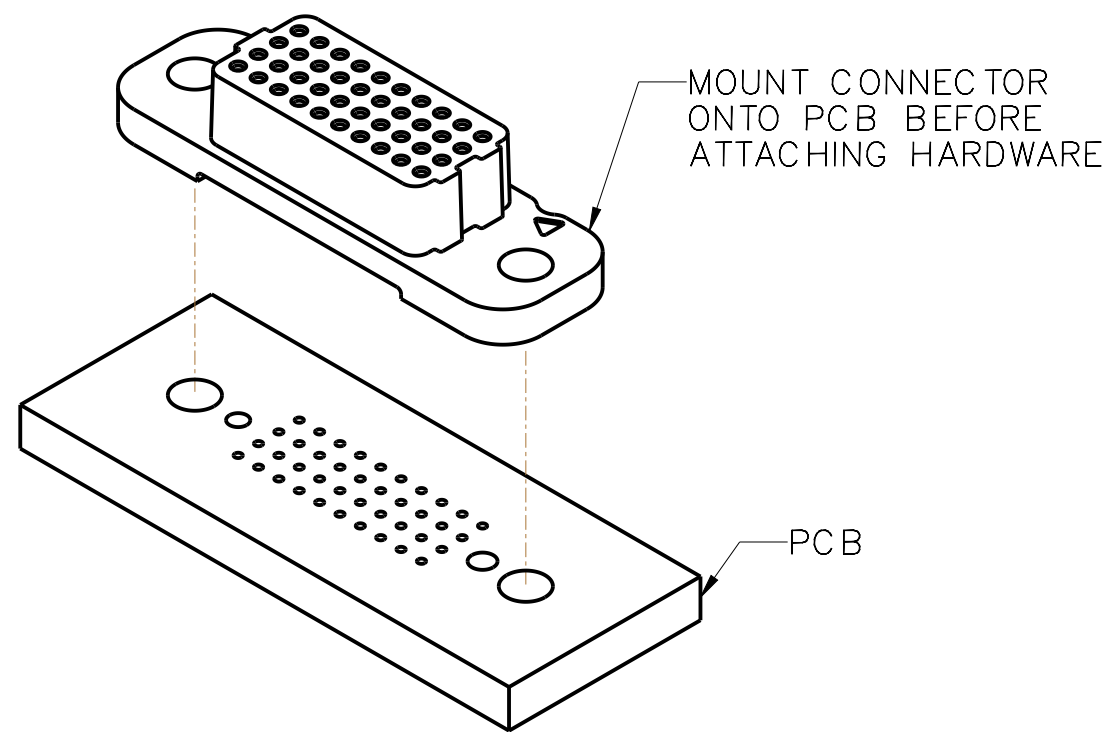

STEP 1:
 PTH, PIH & SMT: SOLDER CONNECTOR ONTO PCB
 PRESS-FIT: PRESS CONNECTOR ONTO PCB
 (SEE ESL5001 FOR MORE DETAILS ON INSTALLING THE CONNECTOR ONTO THE PCB)

RECOMMENDED PCB MOUNTING HARDWARE
 MOUNTING HARDWARE NOT INCLUDED
 WITH BLANK HARDWARE OPTION

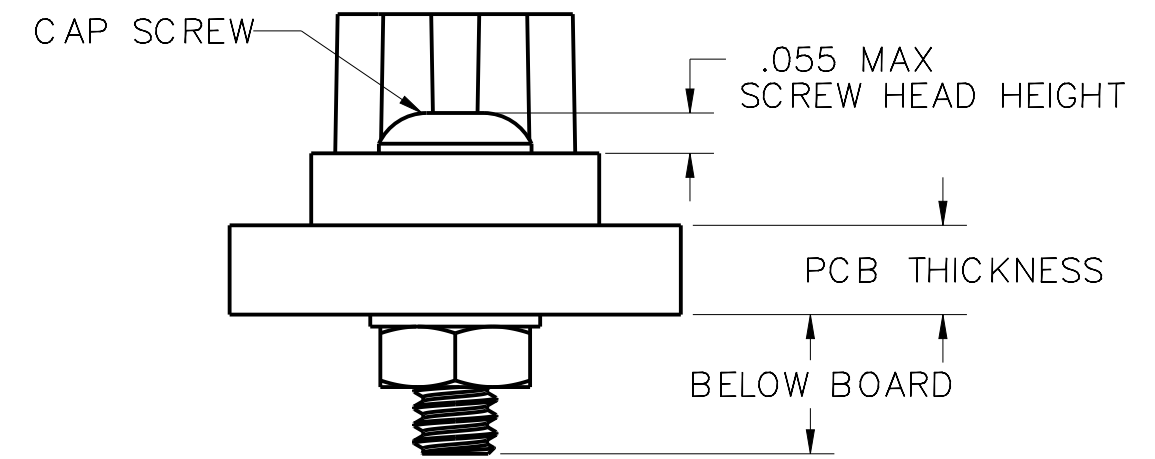

RECOMMENDED SCREWS FOR
 COMMON PCB THICKNESSES

PCB THICKNESS	BUTTON HEAD CAP SCREW	BELOW BOARD
.062	#2-56 X 1/4"	(.114)
.094	#2-56 X 5/16"	(.145)

VSF CONNECTOR MATED TO VSM CONNECTOR

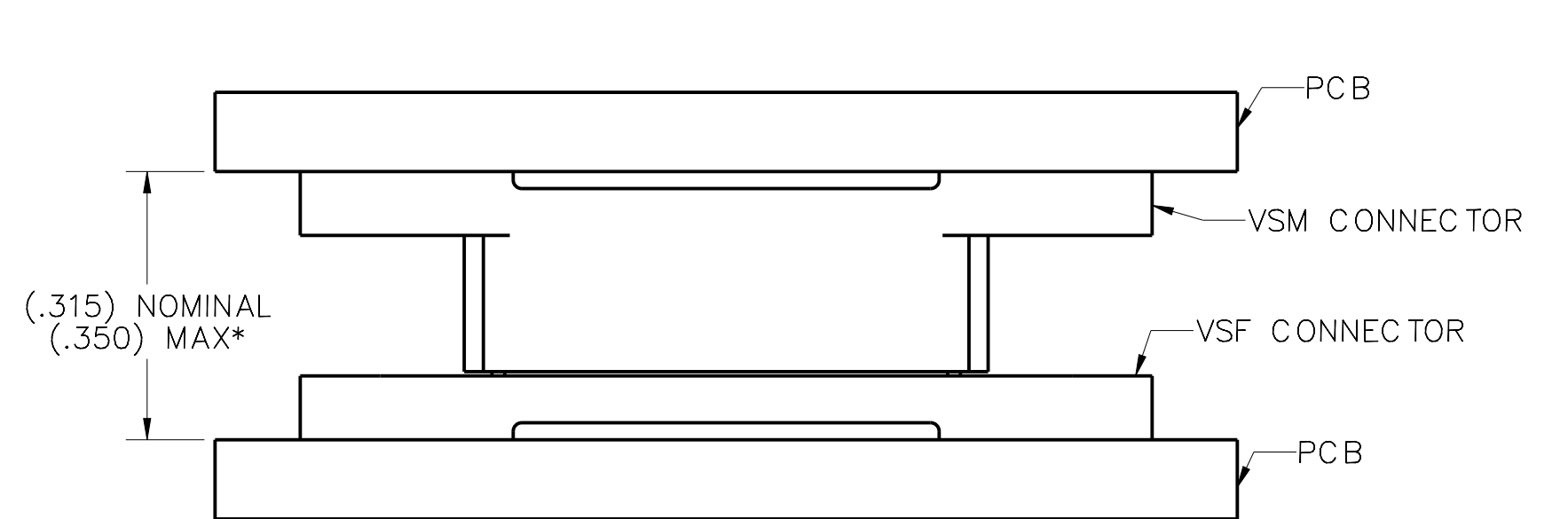

(8MM BOARD SPACING SHOWN)
 SEE VSM-XX-XX-XXX-XX-XX-XX DRAWING
 FOR MORE BOARD SPACING OPTIONS

*MAX VALUE IS AT MAXIMUM
 ALLOWABLE SEPARATION BETWEEN MATED CONNECTORS

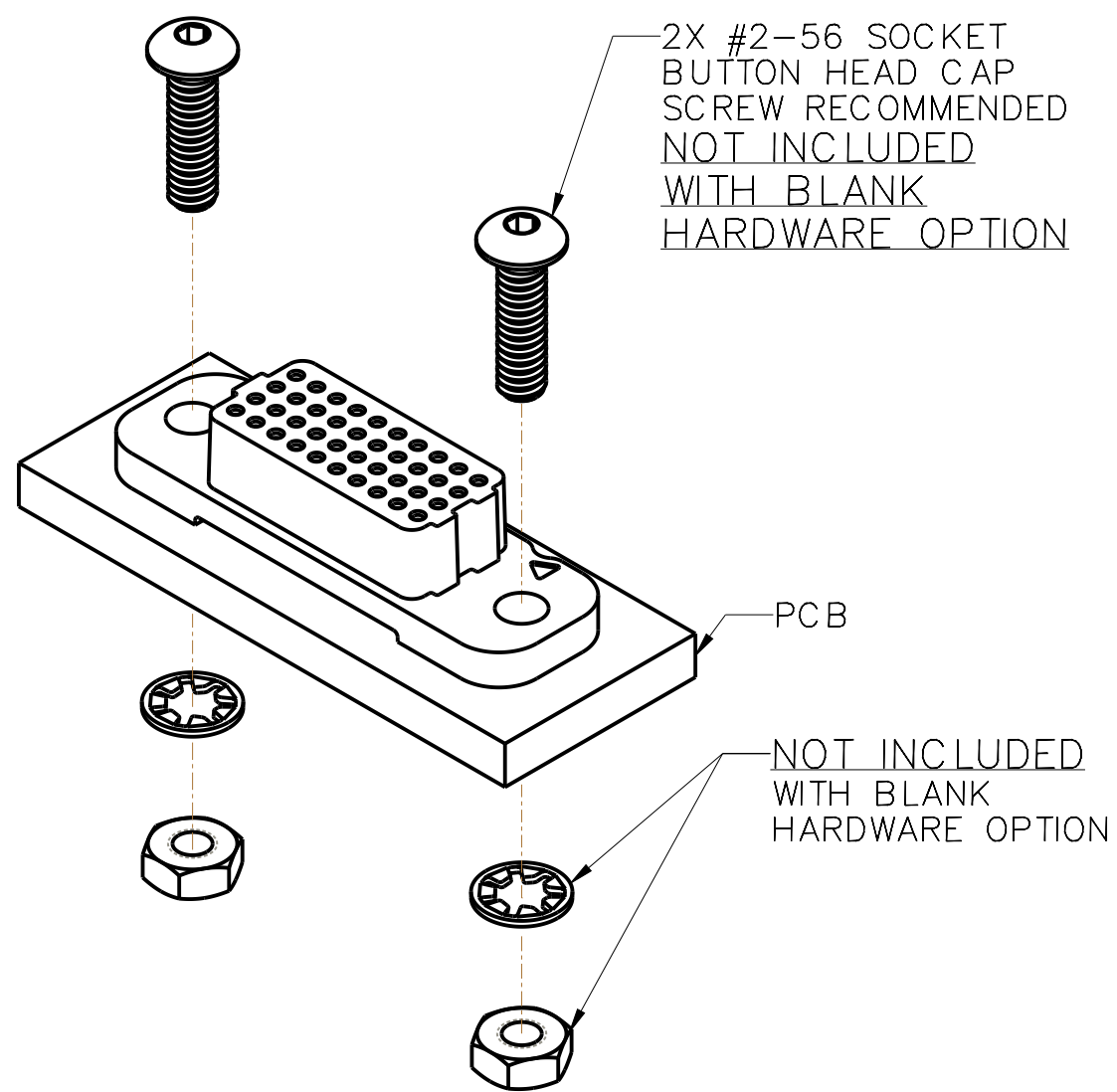

STEP 2:
 ATTACH HARDWARE
 (SEE ESL5001 FOR ADDITIONAL DETAILS AND HARDWARE TORQUE SPECIFICATIONS)

4
3
2
1
C
B
A

FORMAT: CFMTPRO.FRM A.7

RECOMMENDED PCB LAYOUT

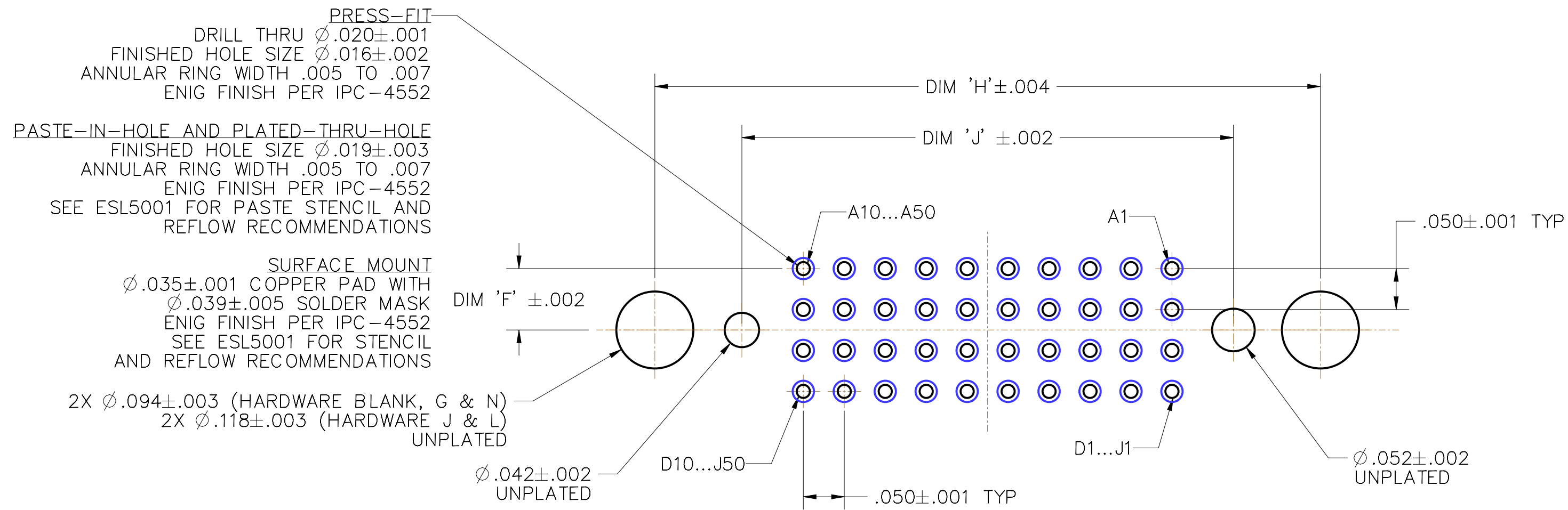

RECOMMENDED BOARD LAYOUT
 COMPONENT SIDE

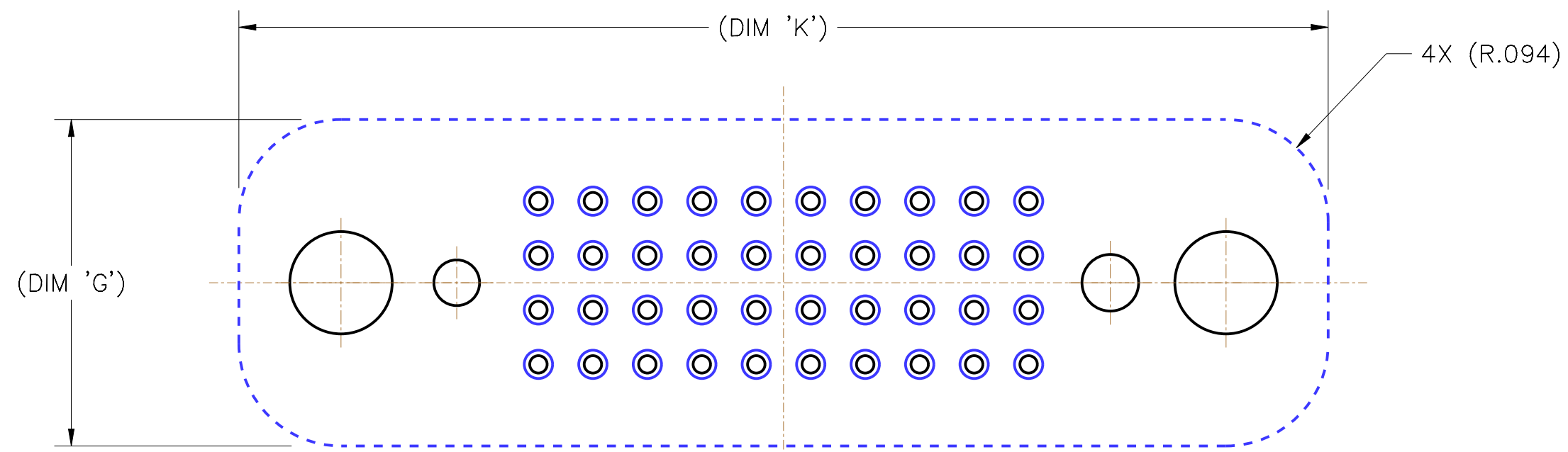

FOOTPRINT
 COMPONENT SIDE

ROWS	DIM 'F'	DIM 'G'
04	.075	.300
05	.100	.350
06	.125	.400
08	.175	.500
10	.225	.600

COLUMNS	DIM 'H'	DIM 'J'	DIM 'K'
10	.813	.600	1.000
20	1.313	1.100	1.500
30	1.813	1.600	2.000
40	2.313	2.100	2.500
50	2.813	2.600	3.000

GUIDE SOCKET DIMENSIONS (HARDWARE OPTIONS G & G1)

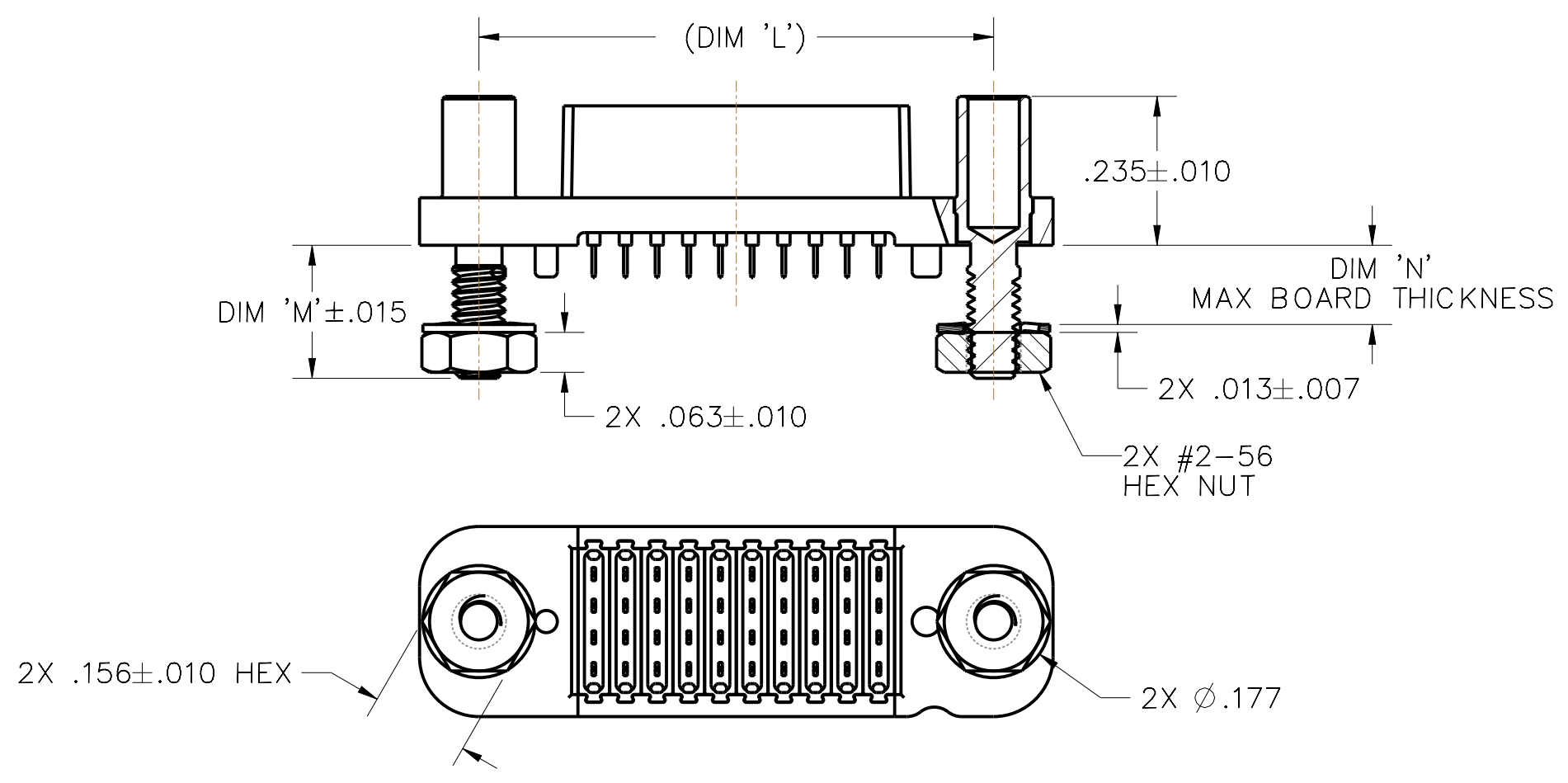

TURNING JACKSCREW DIMENSIONS (HARDWARE OPTIONS J & J1)

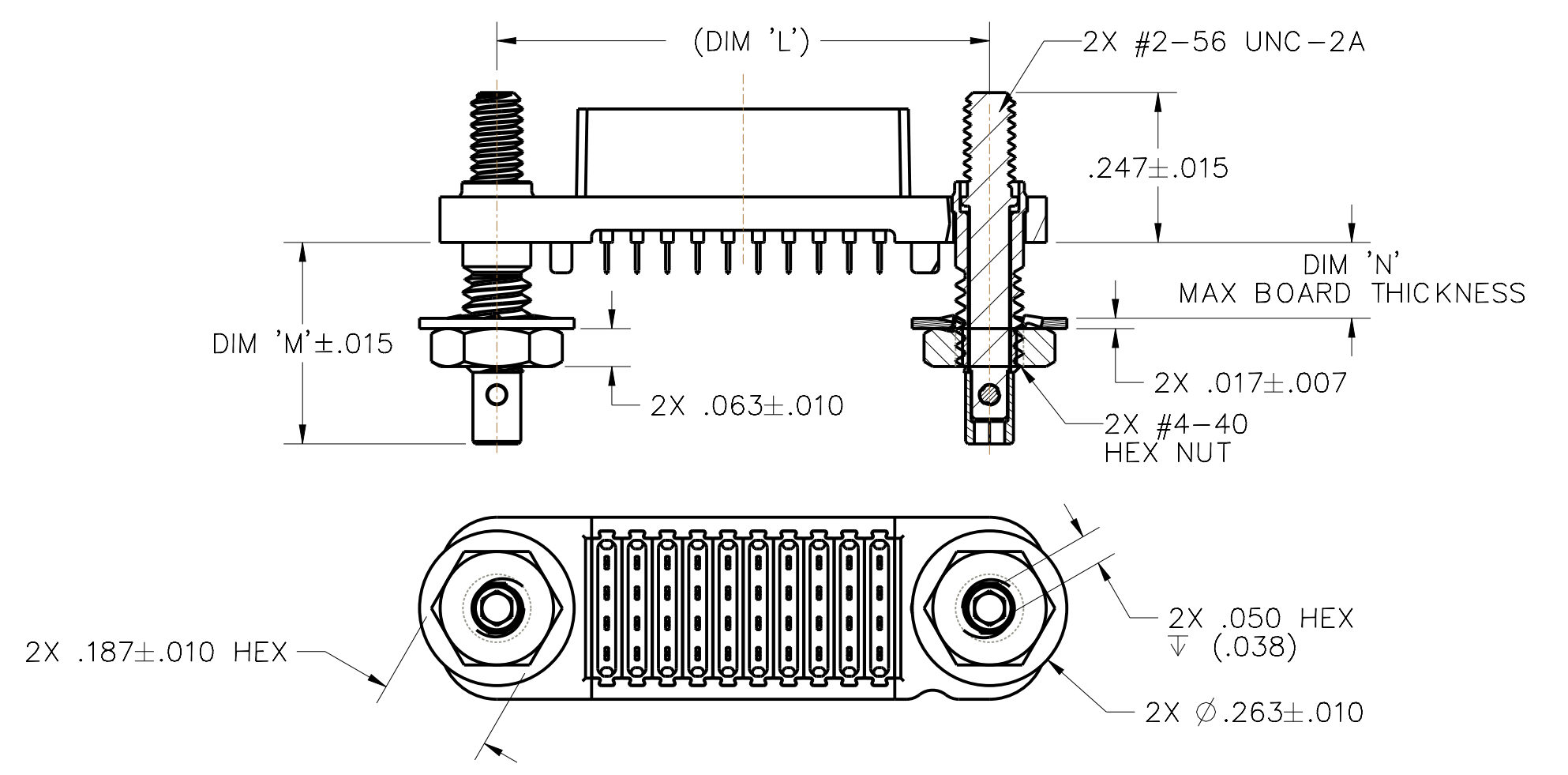

LOCKING SCREW DIMENSIONS (HARDWARE OPTIONS L & L1)

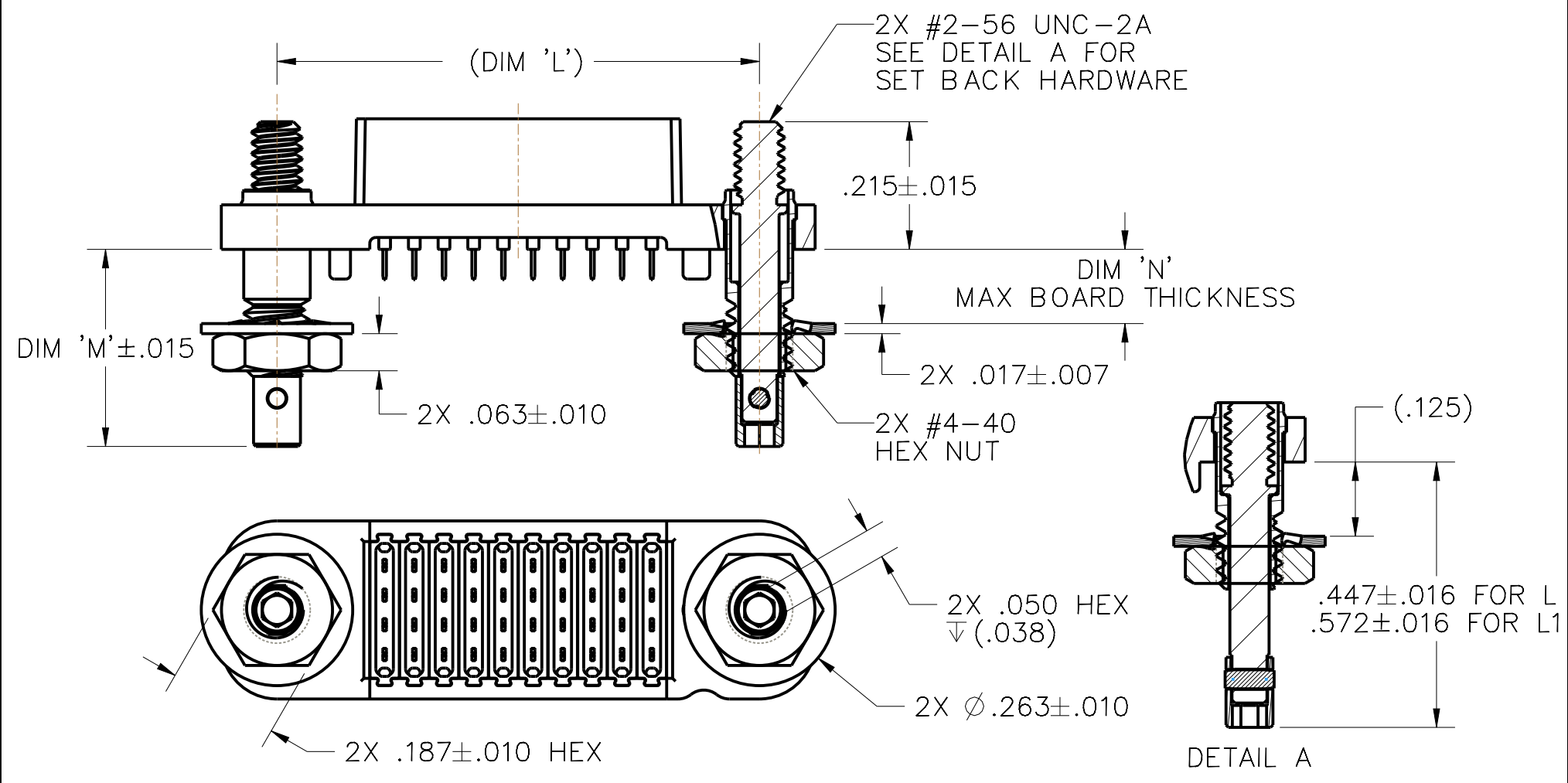

FIXED JACKNUT DIMENSIONS (HARDWARE OPTIONS N & N1)

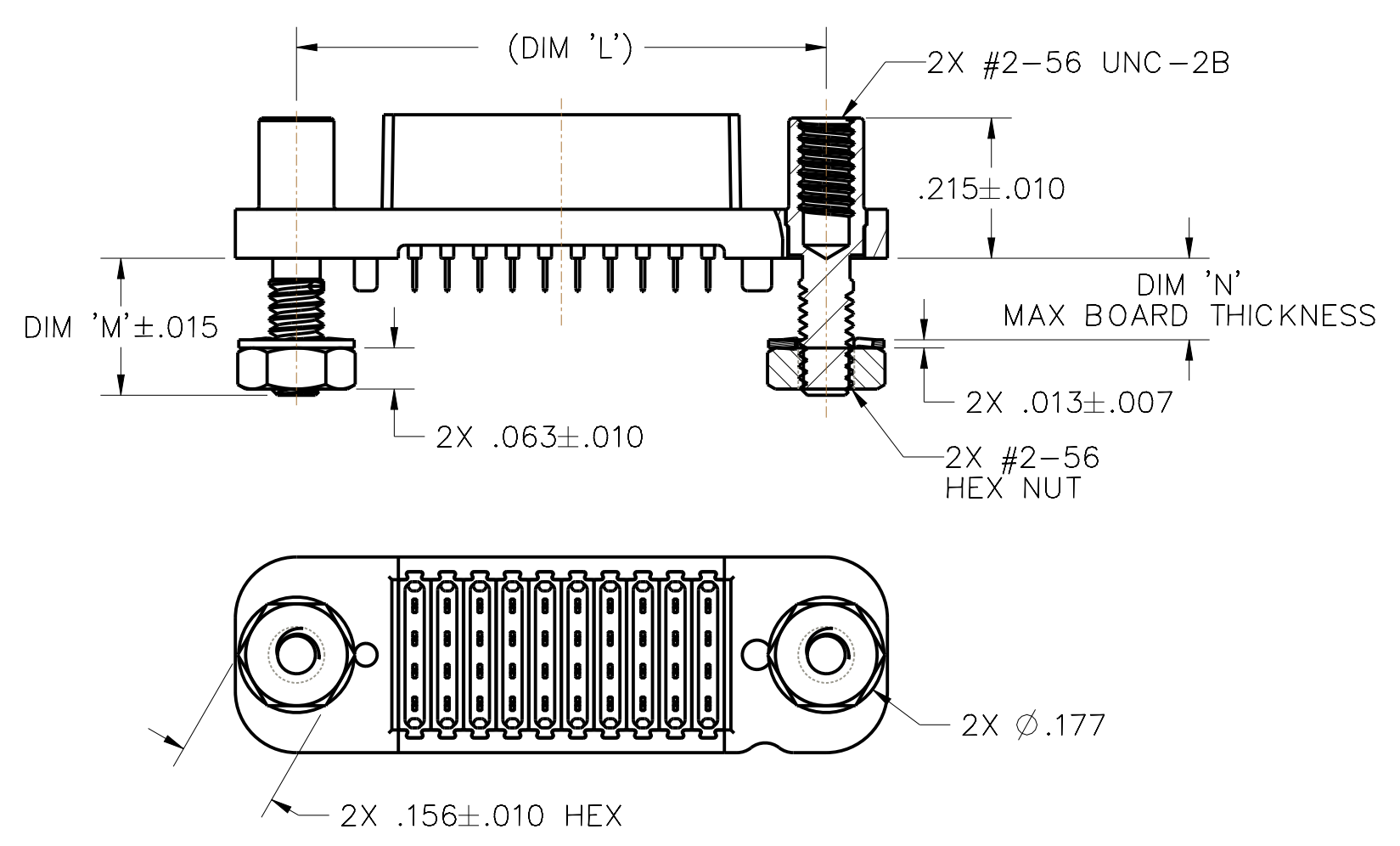

HARDWARE OPTIONS	DESCRIPTION	DIM 'M'	DIM 'N'	COLUMNS	DIM 'L'
G	GUIDE SOCKET	.210	.125	10	.813
G1	GUIDE SOCKET	.335	.250	20	1.313
J	TURNING JACKSCREW	.332	.125	30	1.813
J1	TURNING JACKSCREW	.457	.250	40	2.313
L	LOCKING SCREW	.332	.125	50	2.813
L1	LOCKING SCREW	.457	.250		
N	FIXED JACKNUT	.210	.125		
N1	FIXED JACKNUT	.335	.250		

FORMAT: CFINTPROG.FRM A.7

4

3

2

1

D

C

B

A

HARDWARE KIT PART NUMBER BUILD
 SAMPLE PART NUMBER: VSF-00-00-00-00-G

VSF-00-00-00-00-XX

HARDWARE OPTIONS	
G	GUIDE SOCKET
G1	GUIDE SOCKET
J	TURNING JACKSCREW
J1	TURNING JACKSCREW
L	LOCKING SCREW
L1	LOCKING SCREW
N	FIXED JACKNUT
N1	FIXED JACKNUT

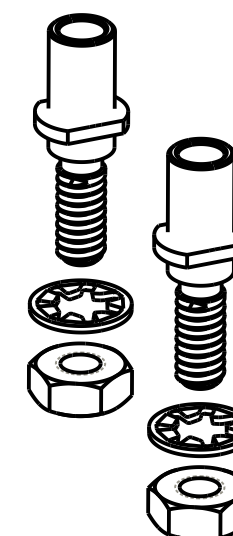

ISOMETRIC VIEW
 FOR REFERENCE ONLY
 (PART NUMBER VSF-00-00-00-00-G SHOWN)

HARDWARE KITS CANNOT BE INSTALLED
 ON CONNECTORS WITH BLANK HARDWARE
 OPTION

GUIDE SOCKET KIT
 (G & G1 HARDWARE OPTIONS)

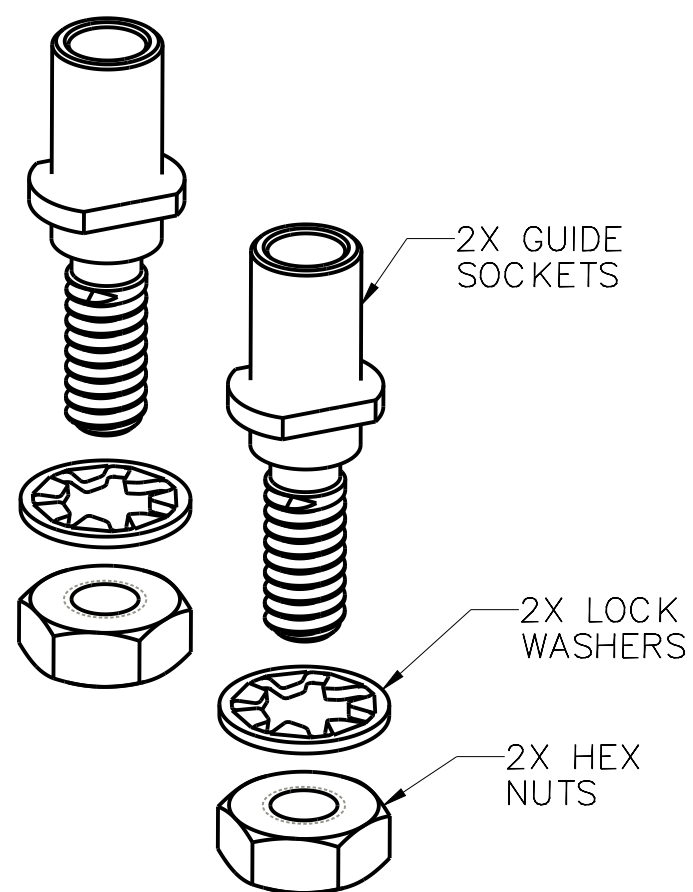

TURNING JACKSCREW KIT
 (J & J1 HARDWARE OPTIONS)

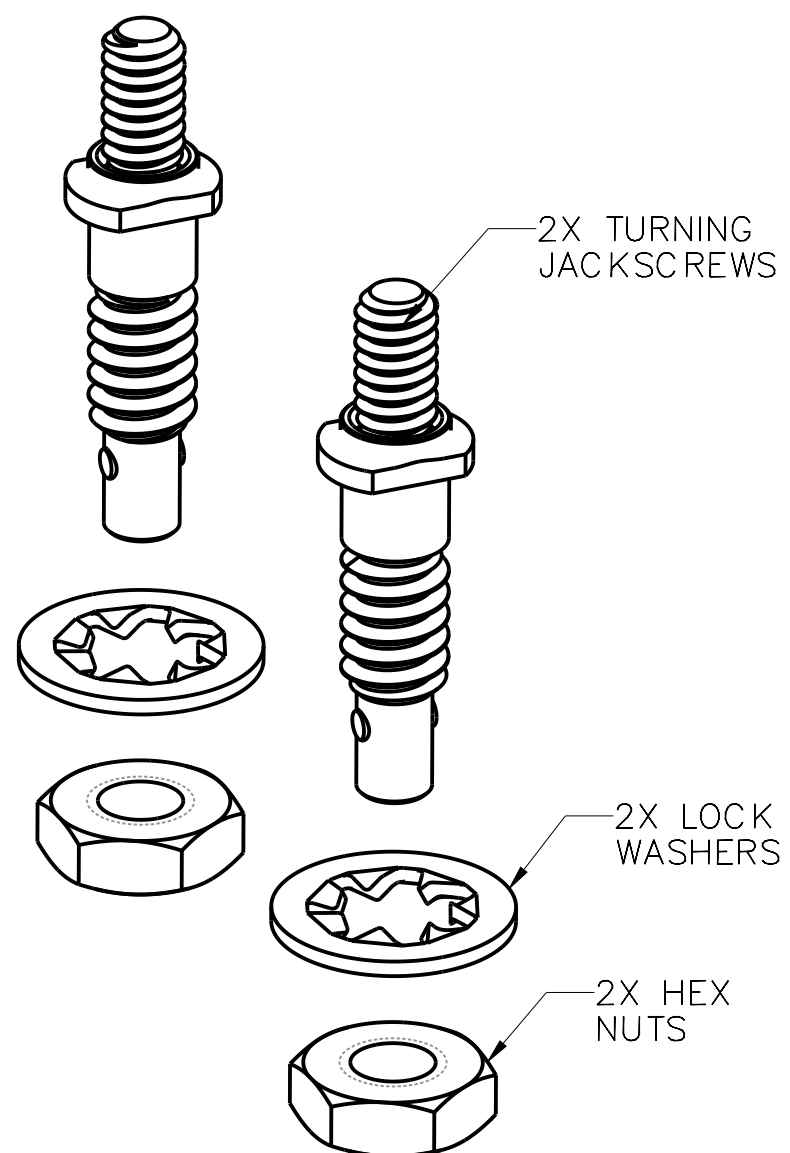

LOCKING SCREW KIT
 (L & L1 HARDWARE OPTIONS)

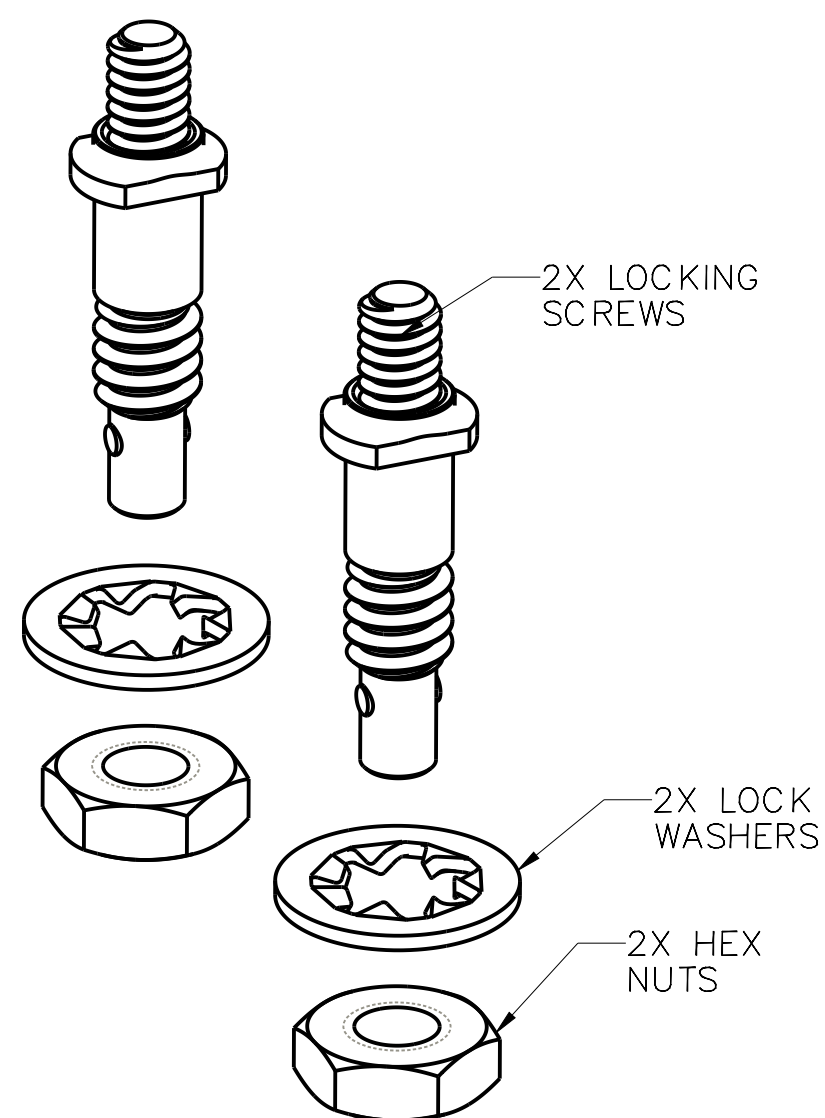

FIXED JACKNUT KIT
 (N & N1 HARDWARE OPTIONS)

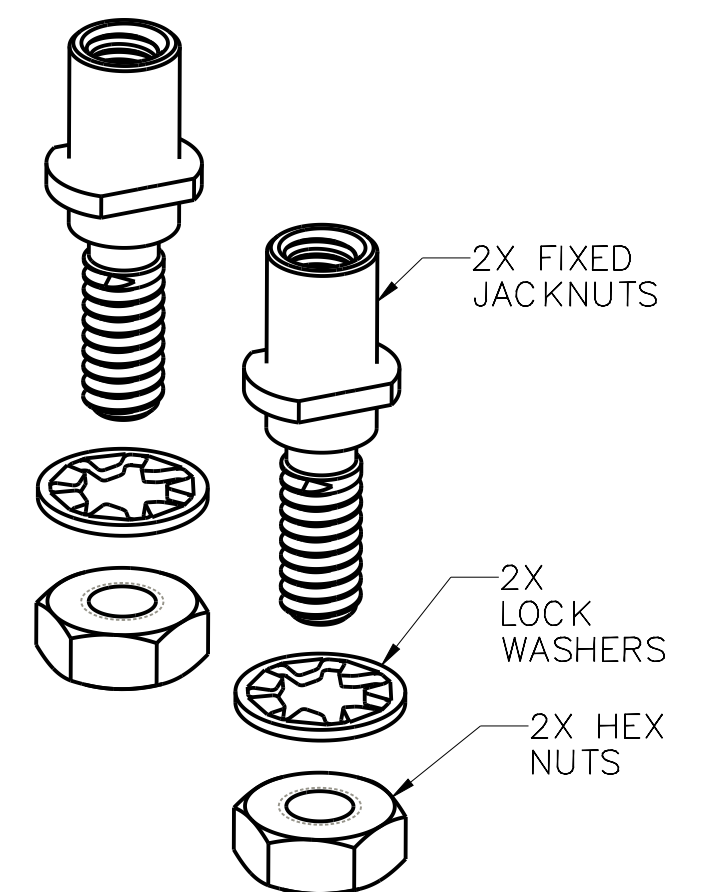

FORMAT: CFMTPROG.FRM A.7

D

C

B

A

4

3

2

1