



NI PS-26

24 V, 10 A, 240 W, SINGLE PHASE INPUT



POWER SUPPLY

- AC 100-240 V Wide-range Input
- Width only 39 mm
- Efficiency up to 95.2%
- Excellent Partial Load Efficiency
- 20% Output Power Reserves (PowerBoost)
- Safe Hiccup^{PLUS} Overload Mode
- Easy Fuse Breaking due to High Overload Peak Current
- Active Power Factor Correction (PFC)
- Minimal Inrush Current Surge
- Full Power Between -25 °C and +60 °C
- DC-OK Relay Contact
- 1 Year Warranty

PRODUCT DESCRIPTION

The NI PS-26 is a high-end power supply in a medium price range without compromising quality, reliability, and performance. The most outstanding features of the NI PS-26 are the high efficiency, advanced inrush current limitation, active PFC, and the wide operational temperature range.

The NI PS-26 includes all the essential basic functions. The device also offers PowerBoost: power reserves of 20%, which may even be used continuously at temperatures up to +45 °C. Additionally, the NI PS-26 can deliver three times the nominal output current for at least 12 ms, which helps to trip fuses on faulty output branches.

High immunity to transients and power surges as well as low electromagnetic emission, a DC-OK relay contact, and a large international approval package for a variety of applications makes this unit suitable for nearly every situation.

SHORT-FORM DATA

Output voltage	DC 24 V	Nominal
Adjustment range	24–28 V	Factory setting 24.1 V
Output current	10.0–8.6 A	Up to +60 °C ambient
	7.5–6.5 A	At +70 °C ambient
	Derate linearly between +60 °C and +70 °C	
PowerBoost	12.0 A	Up to +45 °C ambient
	Linear decrease to nominal power between +45 °C and +60 °C	
Input voltage AC	AC 100-240 V	-15%/+10%
Mains frequency	50-60 Hz	±6%
Input current AC	2.15/1.1 A	At 120/230 Vac
Power factor	0.99/0.97	At 120/230 Vac
Input voltage DC	DC 110-150 V ^{±20%}	
Input current DC	2.35 A	At 110 Vdc
Input inrush current	6/9 A pk	At 40 °C 120/230 Vac
Efficiency	93.6/95.2%	At 120/230 Vac
Losses	16.4/12.1 W	At 120/230 Vac
Hold-up time	37/37 ms	At 120/230 Vac
Temperature range	-25 °C to +70 °C	
Size (w x h x d)	39 x 124 x 117 mm	Without DIN rail
Weight	600 g	

ORDER NUMBERS

Power Supply	NI PS-26	
Accessory	139683-01	Side mounting kit for NI PS-26

MAIN APPROVALS

For details and the complete approval list, see section 20.



Class I Div 2

UL 508



TABLE OF CONTENTS

	Page		Page
1. Intended Use	3	20. Approved, Fulfilled or Tested Standards.....	15
2. Installation Instructions.....	3	21. Regulatory Product Compliance	16
3. AC-Input	4	22. Physical Dimensions and Weight	17
4. DC-Input	5	23. Accessories.....	17
5. Input Inrush Current.....	6	23.1. Side Mounting Bracket—139683-01	17
6. Output	6	24. Application Notes.....	18
7. Hold-up Time.....	8	24.1. Peak Current Capability.....	18
8. DC-OK Relay Contact	8	24.2. Back-feeding Loads	19
9. Efficiency and Power Losses.....	9	24.3. External Input Protection	19
10. Lifetime Expectancy	9	24.4. Output Circuit Breakers.....	19
11. MTBF	10	24.5. Series Operation.....	20
12. Terminals and Wiring	10	24.6. Parallel Use to Increase Output Power	20
13. Functional Diagram	11	24.7. Parallel Use for Redundancy	21
14. Front Side and User Elements	12	24.8. Charging of Batteries.....	21
15. EMC	12	24.9. Operation on Two Phases	22
16. Environment.....	13	24.10. Use in a Tightly Sealed Enclosure	22
17. Protection Features.....	14	24.11. Mounting Orientations.....	22
18. Safety Features.....	14		
19. Dielectric Strength.....	15		

The information given in this document is correct to the best of our knowledge and experience at the time of publication. If not expressly agreed otherwise, this information does not represent a warranty in the legal sense of the word. As the state of our knowledge and experience is constantly changing, the information in this data sheet is subject to revision.

No part of this document may be reproduced or utilized in any form without our prior permission in writing.

TERMINOLOGY AND ABBREVIATIONS

PE and \oplus symbol	PE is the abbreviation for Protective Earth and has the same meaning as the symbol \oplus .
Earth, Ground	This document uses the term “earth” which is the same as the U.S. term “ground.”
t.b.d.	To be defined, value or description will follow later.
AC 230 V	A figure displayed with the AC or DC before the value represents a nominal voltage with standard tolerances (usually $\pm 15\%$) included. For example: DC 12 V describes a 12 V battery disregarding whether it is full (13.7 V) or flat (10 V).
230 Vac	A figure with the unit (Vac) at the end is a momentary figure without any additional tolerances included.
50 Hz vs. 60 Hz	As long as not otherwise stated, AC 100 V and AC 230 V parameters are valid at 50 Hz mains frequency. AC 120 V parameters are valid for 60 Hz mains frequency.
may	A key word indicating flexibility of choice with no implied preference.
shall	A key word indicating a mandatory requirement.
should	A key word indicating flexibility of choice with a strongly preferred implementation.



1. INTENDED USE

This device is designed for installation in an enclosure and is intended for commercial use, such as in industrial control, process control, monitoring, and measurement equipment or the like.

Do not use this device in equipment where malfunctioning may cause severe personal injury or threaten human life without additional appropriate safety devices that are suited for the application.

If this device is used in a manner outside of its specification, the protection provided by the device may be impaired.

2. INSTALLATION INSTRUCTIONS

WARNING Risk of electrical shock, fire, personal injury, or death.

- Turn power off before working on the device and protect against inadvertent re-powering.
- Do not open, modify, or repair the device.
- Use caution to prevent any foreign objects from entering into the housing.
- Do not use in wet locations or in areas where moisture or condensation can be expected.
- Do not touch during power-on, and immediately after power-off. Hot surface may cause burns.

Obey the following installation instructions:

This device may only be installed and put into operation by qualified personnel.

This device does not contain serviceable parts. The tripping of an internal fuse is caused by an internal defect.

If damage or malfunction should occur during installation or operation, immediately turn power off and send unit to the factory for inspection.

Install device in an enclosure providing protection against electrical, mechanical, and fire hazards.

Install the device onto a DIN rail according to EN 60715 with the input terminals on the bottom of the device. Other mounting orientations require a reduction in output current.

Make sure that the wiring is correct by following all local and national codes. Use appropriate copper cables that are designed for a minimum operating temperature of 60 °C for ambient temperatures up to +45 °C, 75 °C for ambient temperatures up to +60 °C, and 90 °C for ambient temperatures up to +70 °C.

Ensure that all strands of a stranded wire enter the terminal connection. Use ferrules for wires on the input terminals. Unused screw terminals should be securely tightened.

The device is designed for pollution degree 2 areas in controlled environments. No condensation or frost is allowed. The enclosure of the device provides a degree of protection of IP20. The enclosure does not provide protection against spilled liquids.

The isolation of the device is designed to withstand impulse voltages of overvoltage category III according to IEC 60664-1.

The device is designed as "Class of Protection I" equipment according to IEC 61140. Do not use without a proper PE (Protective Earth) connection.

The device is suitable to be supplied from TN, TT, or IT mains networks. The continuous voltage between the input terminal and the PE potential must not exceed 300 Vac.

The input can also be powered from batteries or similar DC sources. The continuous voltage between the supply voltage and the PE/ground potential must not exceed 375 Vdc.

A disconnecting means shall be provided for the input of the device.

The device is designed for convection cooling and does not require an external fan. Do not obstruct airflow and do not cover ventilation grid!

The device is designed for altitudes up to 5000 m. Above 2000 m a reduction in output current and over voltage category is required.

Keep the following minimum installation clearances: 40 mm on top, 20 mm on the bottom, 5 mm left and right side. Increase the 5 mm to 15 mm in case the adjacent device is a heat source. When the device is permanently loaded with less than 50%, the 5mm can be reduced to zero.



The device is designed, tested, and approved for branch circuits up to 32 A (IEC) and 30 A (UL) without additional protection device. If an external fuse is utilized, do not use circuit breakers smaller than 6 A B- or C-Characteristic to avoid a nuisance tripping of the circuit breaker.

The maximum surrounding air temperature is +70 °C. The operational temperature is the same as the ambient or surrounding air temperature and is defined 2 cm below the device.

The device is designed to operate in areas between 5% and 95% relative humidity.

Installation Instructions for Hazardous Location Areas

The device is suitable for use in Class I Division 2 Groups A, B, C, D locations.

WARNING EXPLOSION HAZARDS!

Use only in standard vertical mounting orientation with the input terminals on bottom of the unit. Substitution of components may impair suitability for this environment.

Do not disconnect the device or operate the voltage adjustment unless power has been switched off or the area is known to be non-hazardous.

A suitable enclosure must be provided for the end product.

3. AC-INPUT

AC input	Nom.	AC 100-240 V	Suitable for TN-, TT-, and IT mains networks
AC input range		85-264 Vac 264-300 Vac	For maximal 500 ms
Allowed voltage L or N to earth	Max.	300 Vac	Continuous, according to IEC 62477-1
Input frequency	Nom.	50–60 Hz	±6%
Turn-on voltage	Typ.	80 Vac	Steady-state value, see Fig. 3-1
Shut-down voltage	Typ.	70 Vac	Steady-state value, see Fig. 3-1
	Typ.	55 Vac	Dynamic value for maximal 250 ms
External input protection	See recommendations in section 24.3.		

		AC 100 V	AC 120 V	AC 230 V	
Input current	Typ.	2.60 A	2.15 A	1.13 A	At 24 V, 10 A, see Fig. 3-3
Power factor*)	Typ.	0.99	0.99	0.97	At 24 V, 10 A, see Fig. 3-4
Crest factor**)	Typ.	1.5	1.5	1.65	At 24 V, 10 A
Start-up delay	Typ.	300 ms	290 ms	240 ms	See Fig. 3-2
Rise time	Typ.	30 ms	30 ms	30 ms	At 24 V, 10 A const. current load, 0mF load capacitance, see Fig. 3-2
	Typ.	75 ms	75 ms	75 ms	at 24 V, 10 A const. current load, 10 mF load capacitance, see Fig. 3-2
Turn-on overshoot	Max.	200 mV	200 mV	200 mV	See Fig. 3-2
External input protection	See recommendations in section 24.3.				

*) The power factor is the ratio of the true (or real) power to the apparent power in an AC circuit.

**) The crest factor is the mathematical ratio of the peak value to RMS value of the input current waveform.

Fig. 3-1 Input voltage range

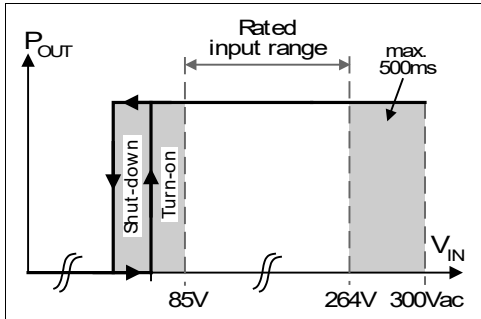

Fig. 3-2 Turn-on behavior, definitions

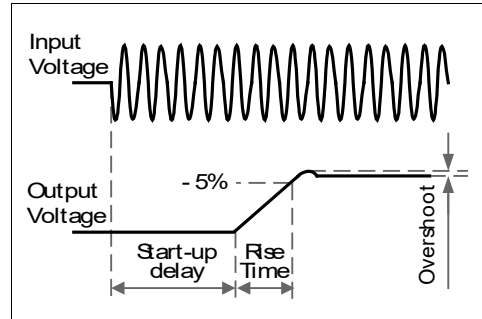

Fig. 3-3 Input current vs. output current at 24V output voltage

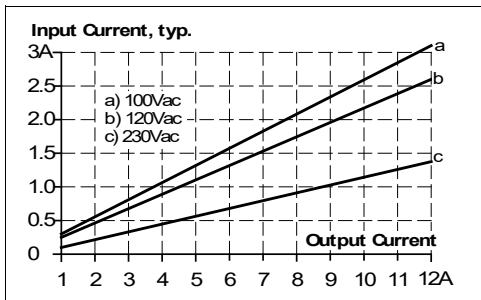
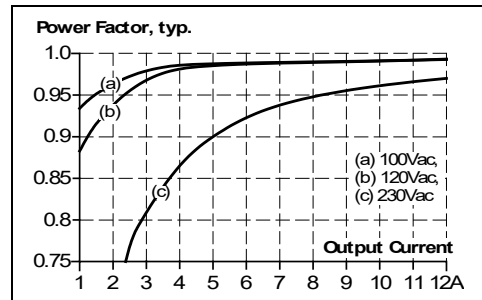

Fig. 3-4 Power factor vs. output current at 24V output voltage



4. DC-INPUT

DC input	Nom.	DC 110-150 V	±20%
DC input range		88-180 Vdc	
DC input current	Typ.	2.35 A	At 110 Vdc, at 24 V, 10 A
Allowed Voltage L/N to Earth	Max.	375 Vdc	Continuous, according to IEC 62477-1
Turn-on voltage	Typ.	80 Vdc	Steady state value
Shut-down voltage	Typ.	70 Vdc	Steady state value
	Typ.	55 Vdc	Dynamic value for maximal 250 ms

Fig. 4-1 Wiring for DC Input

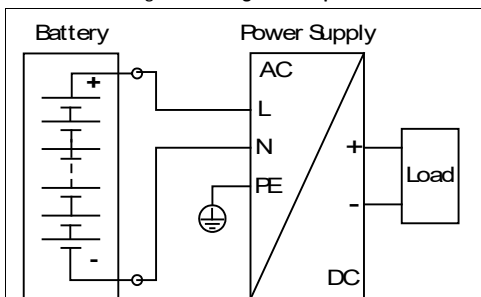

Instructions for DC use:

- Use a battery or a similar DC source. A supply from the intermediate DC-bus of a frequency converter is not recommended and can cause a malfunction or damage the unit.
- Connect +pole to L and -pole to N.
- Connect the PE terminal to an earth wire or to the machine ground.

5. INPUT INRUSH CURRENT

An active inrush limitation circuit (NTCs, which are bypassed by a relay contact) limits the input inrush current after turn-on of the input voltage.

The charging current into EMI suppression capacitors is disregarded in the first microseconds after switch-on.

		AC 100 V	AC 120 V	AC 230 V	
Inrush current	Max.	11 A _{peak}	7 A _{peak}	11 A _{peak}	At 40°C, cold start
	Typ.	9 A _{peak}	6 A _{peak}	6 A _{peak}	At 25°C, cold start
	Typ.	9 A _{peak}	6 A _{peak}	9 A _{peak}	At 40°C, cold start
Inrush energy	Max.	0.1 A ² s	0.1 A ² s	0.4 A ² s	At 40°C, cold start

Fig. 5-1 Typical turn-on behaviour at nominal load, 120 Vac input and 25 °C ambient

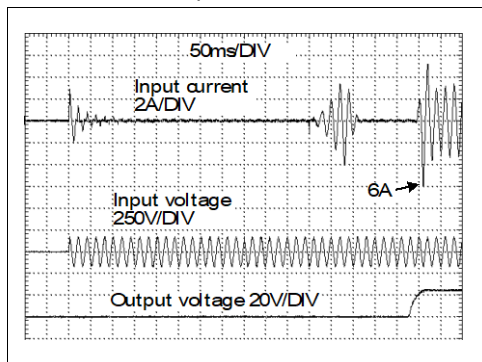
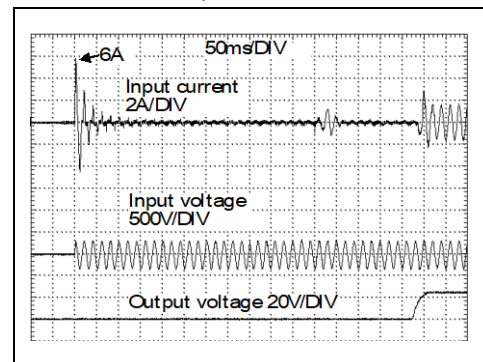

Fig. 5-2 Typical turn-on behaviour at nominal load, 230 Vac input and 25 °C ambient



6. OUTPUT

Output voltage	Nom.	24 V	
Adjustment range		24-28 V	Guaranteed value
	Max.	30.0 V	This is the maximum output voltage which can occur at the clockwise end position of the potentiometer due to tolerances. It is not a guaranteed value which can be achieved.
Factory settings	Typ.	24.1 V	±0.2%, at full load and cold unit
Line regulation	Max.	10 mV	Between 85 and 300 Vac
Load regulation	Max.	50 mV	Between 0 and 12 A, static value, see Fig. 6-1
Ripple and noise voltage	Max.	50 mVpp	Bandwidth 20 Hz to 20 MHz, 50 Ohm
Output current	Nom.	10 A	At 24 V and up to +60 °C ambient temperature, see Fig. 6-1
	Nom.	7.5 A	At 24 V and +70 °C ambient temperature, see Fig. 16-1
	Nom.	8.6 A	At 28 V up to +60 °C ambient temperature, see Fig. 6-1
	Nom.	6.45 A	At 28 V and +70 °C ambient temperature, see Fig. 16-1
			Derate linearly between +60 °C and +70 °C, see section 16
PowerBoost ¹⁾	Nom.	12 A	At 24 V and up to +45 °C ambient temperature, see Fig. 16-1
	Nom.	10.3 A	At 28 V and up to +45 °C ambient temperature, see Fig. 16-1
			PowerBoost decreases linearly to nominal power between +45 °C and +60 °C, see section 16

Fuse breaking current	Typ.	30 A	For minimal 12 ms once every five seconds, see Fig. 6-2. The output voltage stays above 20 V. See section 24.1 for more peak current measurements. For AC 100 V mains, the pulse length is shorter than 12 ms.
Overload behaviour		Continuous current Hiccup ^{PLUS} mode ²⁾	Output voltage above 13 Vdc, see Fig. 6-1 Output voltage below 13 Vdc, see Fig. 6-1
Short-circuit current	Min.	12.5 A ³⁾	Load impedance <45 mOhm, see Fig. 6-3
	Max.	15.5 A ³⁾	Load impedance <45 mOhm, see Fig. 6-3
	Max.	5 A	Average (R.M.S.) current, load impedance 50 mOhm, see Fig. 6-3
	Min.	28 A	Up to 12 ms, load impedance <45 mOhm, see Fig. 6-2
	Typ.	30.5 A	Up to 12 ms, load impedance <45 mOhm, see Fig. 6-2
Output capacitance	Typ.	4400 μ F	Included inside the power supply

1) PowerBoost

This power/ current is continuously allowed up to an ambient temperature of +45 °C.

Above +45 °C, do not use this power or current longer than a duty cycle of 10% and/or not longer than 1 minute every 10 minutes.

2) Hiccup^{PLUS} Mode

At heavy overloads (when output voltage falls below 13 V), the power supply delivers continuous output current for 2 s. After this, the output is switched off for approx. 18 s before a new start attempt is automatically performed. This cycle is repeated as long as the overload exists. If the overload has been cleared, the device will operate normally. See Fig. 6-3.

3) Discharge current of output capacitors is not included.

Fig. 6-1 Output voltage vs. output current, typ.

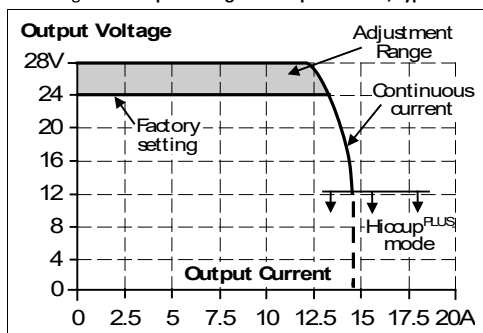

Fig. 6-2 Dynamic output current capability, typ.

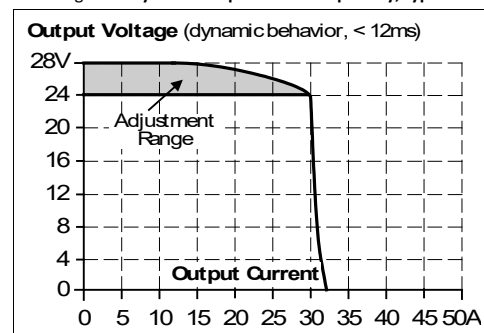
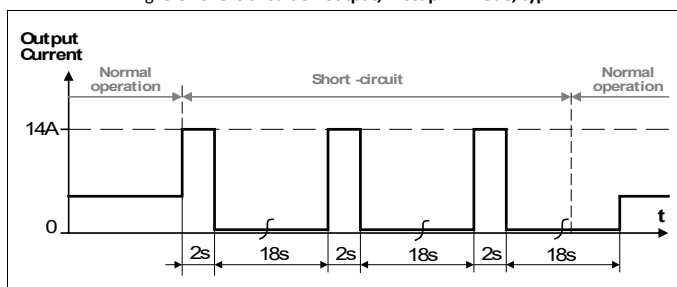

Fig. 6-3 Short-circuit on output, Hiccup^{PLUS} mode, typ.



7. HOLD-UP TIME

		AC 100 V	AC 120 V	AC 230 V	
Hold-up Time	Typ.	73 ms	73 ms	73 ms	At 24 V, 5 A, see Fig. 7-1
	Min.	55 ms	55 ms	55 ms	At 24 V, 5 A, see Fig. 7-1
	Typ.	37 ms	37 ms	37 ms	At 24 V, 10 A, see Fig. 7-1
	Min.	28 ms	28 ms	28 ms	At 24 V, 10 A, see Fig. 7-1

Fig. 7-1 Hold-up time vs. input voltage

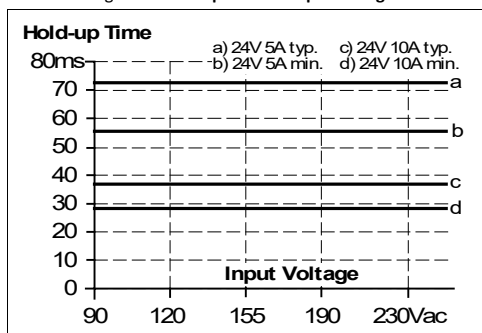
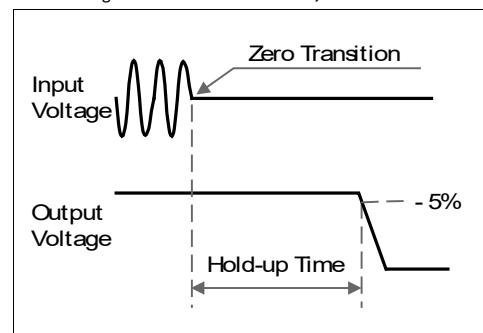

Fig. 7-2 Shut-down behavior, definitions



8. DC-OK RELAY CONTACT

This feature monitors the output voltage on the output terminals of a running power supply.

Contact closes	As soon as the output voltage reaches typ. 90% of the adjusted output voltage level.
Contact opens	As soon as the output voltage dips more than 10% below the adjusted output voltage. Short dips will be extended to a signal length of 100 ms. Dips shorter than 1 ms will be ignored.
Switching hysteresis	1 V
Contact ratings	Maximal 60 Vdc 0.3 A, 30 Vdc 1 A, 30 Vac 0.5 A, resistive load Minimal permissible load: 1 mA at 5 Vdc
Isolation voltage	See dielectric strength table in section 18.

Fig. 8-1 DC-OK relay contact behavior

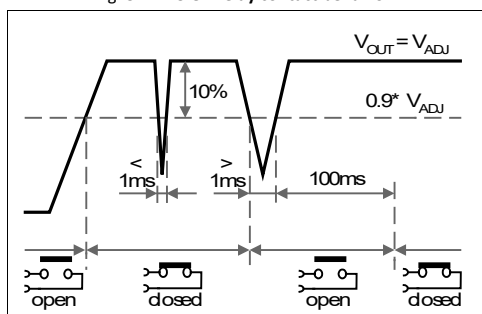

9. EFFICIENCY AND POWER LOSSES

		AC 100 V	AC 120 V	AC 230 V	
Efficiency	Typ.	92.9%	93.6%	95.2%	At 24 V, 10 A
	Typ.	92.5%	93.4%	95.1%	At 24 V, 12 A (PowerBoost)
Average efficiency ^{*)}	Typ.	92.5%	93.0%	94.3%	25% at 2.5 A, 25% at 5 A, 25% at 7.5 A. 25% at 10 A
Power losses	Typ.	2.5 W	2.1 W	1.8 W	At 24 V, 0 A
	Typ.	9.8 W	8.9 W	7.1 W	At 24 V, 5 A
	Typ.	18.3 W	16.4 W	12.1 W	At 24 V, 10 A
	Typ.	23.4 W	21.7 W	14.8 W	At 24 V, 12 A (PowerBoost)

*) The average efficiency is an assumption for a typical application where the power supply is loaded with 25% of the nominal load for 25% of the time, 50% of the nominal load for another 25% of the time, 75% of the nominal load for another 25% of the time, and with 100% of the nominal load for the rest of the time.

Fig. 9-1 Efficiency vs. output current at 24 V, typ.

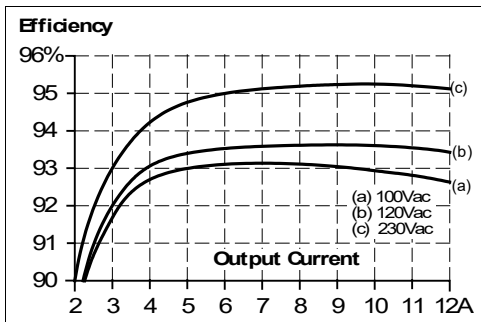

Fig. 9-2 Losses vs. output current at 24 V, typ.

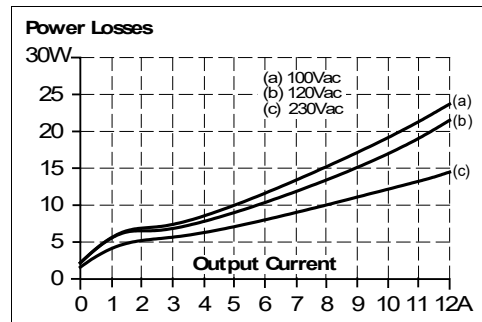

Fig. 9-3 Efficiency vs. input voltage at 24 V, 10 A, typ.

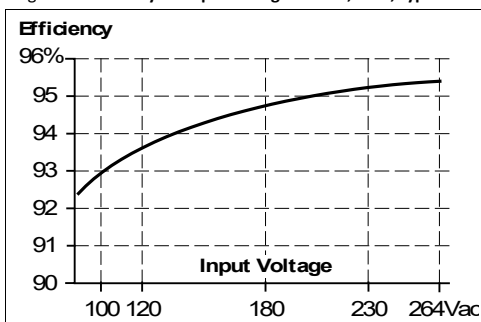
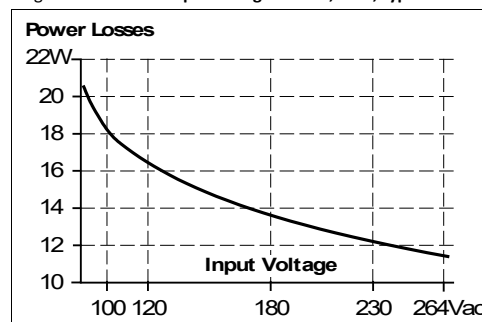

Fig. 9-4 Losses vs. input voltage at 24 V, 10 A, typ.



10. LIFETIME EXPECTANCY

The Lifetime expectancy shown in the table indicates the minimum operating hours (service life) and is determined by the lifetime expectancy of the built-in electrolytic capacitors. Lifetime expectancy is specified in operational hours and is calculated according to the capacitor's manufacturer specification. The manufacturer of the electrolytic capacitors only guarantees a maximum life of up to 15 years (131,400 h). Any number exceeding this value is a calculated theoretical lifetime which can be used to compare devices.



	AC 100 V	AC 120 V	AC 230 V	
Lifetime expectancy	128,000 h	141,000 h	176,000 h	At 24 V, 5 A and 40 °C
	61,000 h	75,000 h	120,000 h	At 24 V, 10 A and 40 °C
	47,000 h	59,000 h	101,000 h	At 24 V, 12 A and 40 °C
	363,000 h	399,000 h	499,000 h	At 24 V, 5 A and 25 °C
	173,000 h	211,000 h	338,000 h	At 24 V, 10 A and 25 °C
	132,000 h	166,000 h	286,000 h	At 24 V, 12 A and 25 °C

11. MTBF

MTBF stands for **Mean Time Between Failure**, which is calculated according to statistical device failures and indicates reliability of a device. It is the statistical representation of the likelihood of a unit to fail and does not necessarily represent the life of a product.

The MTBF figure is a statistical representation of the likelihood of a device to fail. A MTBF figure of, for example, 1,000,000 h means that statistically one unit will fail every 100 hours if 10,000 units are installed in the field. However, it cannot be determined if the failed unit has been running for 50,000 h or only for 100 h.

For these types of units the MTTF (**Mean Time To Failure**) value is the same value as the MTBF value.

	AC 100 V	AC 120 V	AC 230 V	
MTBF SN 29500, IEC 61709	550,000 h	560,000 h	661,000 h	At 24 V, 10 A and 40 °C
	1,003,000 h	1,017,000 h	1,176,000 h	At 24 V, 10 A and 25 °C
MTBF MIL HDBK 217F	188,000 h	188,000 h	213,000 h	At 24 V, 10 A and 40 °C; Ground Benign GB40
	252,000 h	252,000 h	290,000 h	At 24 V, 10 A and 25 °C; Ground Benign GB25
	40,000 h	40,000 h	47,000 h	At 24 V, 10 A and 40 °C; Ground Fixed GF40
	51,000 h	51,000 h	61,000 h	At 24 V, 10 A and 25 °C; Ground Fixed GF25

12. TERMINALS AND WIRING

The terminals are IP20 Finger safe constructed and suitable for field- and factory wiring.

NI PS-26	Input	Output	DC-OK-Signal
Type	Quick-connect spring-clamp terminal	Quick-connect spring-clamp terminal	Push-in terminal
Solid wire	Max. 6 mm ²	Max. 6 mm ²	Max. 1.5 mm ²
Stranded wire	Max. 4 mm ²	Max. 4 mm ²	Max. 1.5 mm ²
American Wire Gauge	AWG 20-10	AWG 20-10	AWG 24-16
Max. wire diameter (including ferrules)	2.8 mm	2.8 mm	1.6 mm
Wire stripping length	10 mm	10 mm	7 mm
Screwdriver	-	-	3 mm slotted to open the spring

Instructions for wiring:

- a) Use appropriate copper cables that are designed for minimum operating temperatures of:
 60 °C for ambient up to 45 °C and
 75 °C for ambient up to 60 °C and
 90 °C for ambient up to 70 °C minimum.
- b) Follow national installation codes and installation regulations!
- c) Ensure that all strands of a stranded wire enter the terminal connection!
- d) Unused terminal compartments should be securely tightened.
- e) Ferrules are allowed.

Daisy chaining:

Daisy chaining is allowed for the NI PS-26.

Daisy chaining (jumping from one power supply output to the next) is allowed as long as the average output current through one terminal pin does not exceed 25 A. If the current is higher, use a separate distribution terminal block as shown in Fig. 12-2.

Fig. 12-1 Daisy chaining of outputs

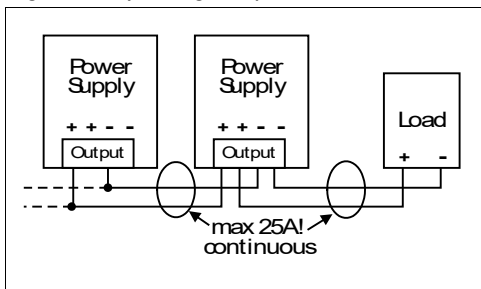
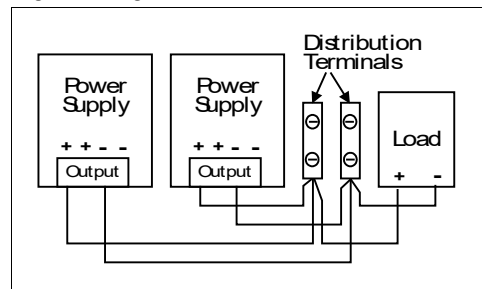
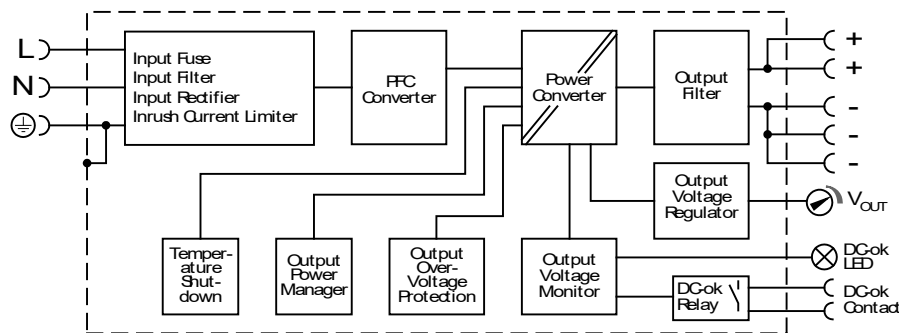

Fig. 12-2 Using distribution terminals



13. FUNCTIONAL DIAGRAM

Fig. 13-1 Functional diagram



14. FRONT SIDE AND USER ELEMENTS



A Output Terminals

(two identical + poles and three identical - poles)

Spring-clamp terminals

- + Positive output
- Negative (return) output

B Output voltage potentiometer

Open the flap to adjust the output voltage. Factory set: 24.1 V

C DC-OK LED (green)

On, when the output voltage is in range and the DC-OK contact is closed.

D DC-OK Relay Contact (push-in terminals)

Monitors the output voltage of the running power supply. See section 8 for details.

E Input Terminals

Spring-clamp terminals

- N, L Line input
- ⊕ PE (Protective Earth) input

15. EMC

The power supply is suitable for applications in industrial environment as well as in residential, commercial, and light industry environments.

EMC Immunity	According to generic standards: EN 61000-6-1 and EN 61000-6-2			
Electrostatic discharge	EN 61000-4-2	Contact discharge	8 kV	Criterion A
		Air discharge	15 kV	Criterion A
Electromagnetic RF field	EN 61000-4-3	80 MHz-2.7 GHz	20 V/m	Criterion A
Fast transients (Burst)	EN 61000-4-4	Input lines	4 kV	Criterion A
		Output lines	2 kV	Criterion A
		DC-OK signal (coupling clamp)	2 kV	Criterion A
Surge voltage on input	EN 61000-4-5	L → N	2 kV	Criterion A
		L → PE, N → PE	4 kV	Criterion A
Surge voltage on output	EN 61000-4-5	+ → -	1 kV	Criterion A
		+ / - → PE	2 kV	Criterion A
Surge voltage on Signals	EN 61000-4-5	DC-OK signal → PE	1 kV	Criterion A
Conducted disturbance	EN 61000-4-6	0.15-80 MHz	20 V	Criterion A
Mains voltage dips	EN 61000-4-11	0% of 100 Vac	0 Vac, 20 ms	Criterion A
		40% of 100 Vac	40 Vac, 200 ms	Criterion C
		70% of 100 Vac	70 Vac, 500 ms	Criterion C
		0% of 200 Vac	0 Vac, 20 ms	Criterion A
		40% of 200 Vac	80 Vac, 200 ms	Criterion A
		70% of 200 Vac	140 Vac, 500 ms	Criterion A
Voltage interruptions	EN 61000-4-11	0% of 200 Vac (= 0V)	5000 ms	Criterion C



Voltage sags	SEMI F47	Dips on the input voltage according to SEMI F47 standard		
		80% of 120 Vac (96 Vac)	1000 ms	Criterion A
		70% of 120 Vac (84 Vac)	500 ms	Criterion A
		50% of 120 Vac (60 Vac)	200 ms	Criterion A
Powerful transients	VDE 0160	Over entire load range	750 V, 0.3 ms	Criterion A

Criteria:
A: Power supply shows normal operation behavior within the defined limits.
C: Temporary loss of function is possible. Power supply may shut-down and restarts by itself. No damage or hazards for the power supply will occur.

EMC Emission	According to generic standards: EN 61000-6-3 and EN 61000-6-4		
Conducted emission input lines	EN 55011, EN 55015, EN 55032, FCC Part 15, CISPR 11, CISPR 32	Class B	
Conducted emission output lines ²⁾	IEC/CISPR 16-1-2, IEC/CISPR 16-2-1	Limits for DC power port according EN 61000-6-3 fulfilled	
Radiated emission	EN 55011, EN 55032	Class B	
Harmonic input current	EN 61000-3-2	Class A fulfilled between 0 A and 12 A load Class C fulfilled between 6 A and 12 A load	
Voltage fluctuations, flicker	EN 61000-3-3	Fulfilled ¹⁾	

This device complies with FCC Part 15 rules.
 Operation is subjected to following two conditions: (1) this device may not cause harmful interference, and (2) this device must accept any interference received, including interference that may cause undesired operation.

- 1) Tested with constant current loads, non pulsing
- 2) For information only, not mandatory for EN 61000-6-3

Switching Frequencies		
PFC converter	110 kHz	Fixed frequency
Main converter	84 kHz to 140 kHz	Output load dependent
Auxiliary converter	60 kHz	Fixed frequency

16. ENVIRONMENT

Operational temperature ¹⁾	-25 °C to +70 °C	Reduce output power according to Fig. 16-1
Storage temperature	-40 °C to +85 °C	For storage and transportation
Output derating	6 W/K	Between +60 °C and +70 °C
Humidity	5 to 95% r.h.	According to IEC 60068-2-30 Do not energize while condensation is present.
Vibration sinusoidal ²⁾	2-17.8 Hz: ±1.6 mm; 17.8-500 Hz: 2 g 2 hours/axis	According to IEC 60068-2-6
Shock ²⁾	30 g 6 ms, 20 g 11 ms 3 bumps/direction, 18 bumps in total	According to IEC 60068-2-27
Altitude	0 to 2000 m 2000 to 6000 m	Without any restrictions Reduce output power or ambient temperature, see Fig. 16-2.
Altitude derating	15 W/1000 m or 5 K/1000 m	For altitudes >2000 m, see Fig. 16-2
Over-voltage category	III II	According to IEC 62477-1 for altitudes up to 2000 m According to IEC 62477-1 for altitudes from 2000 m to 6000 m

Degree of pollution	2	According to IEC 62477-1, not conductive
Audible noise	Some audible noise may be emitted from the power supply during no load, overload, or short circuit.	
	1) Operational temperature is the same as the ambient or surrounding temperature and is defined as the air temperature 2 cm below the unit. 2) Tested in combination with DIN rails according to EN 60715 with a height of 15 mm and a thickness of 1.3 mm and standard orientation.	

Fig. 16-1 Output current vs. ambient temp.
(Inom 10 A; Iout with PowerBoost = 12 A)

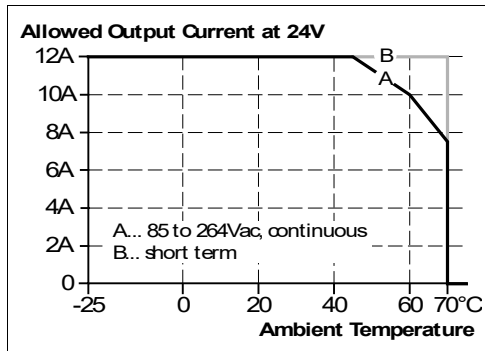
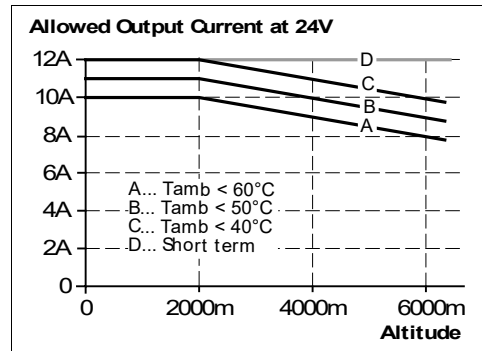

Fig. 16-2 Output current vs. altitude



17. PROTECTION FEATURES

Output protection	Electronically protected against overload, no-load and short-circuits. In case of a protection event, audible noise may occur.	
Output over-voltage protection	Typ. 30.5 Vdc Max. 32 Vdc	In case of an internal power supply defect, a redundant circuit limits the maximum output voltage. The output shuts down and automatically attempts to restart.
Degree of protection	IP 20	EN/IEC 60529
Penetration protection	> 4 mm	For example, screws, small parts
Over-temperature protection	Yes	Output shut-down with automatic restart. The temperature sensor is installed on critical components inside the unit and turns the unit off in safety critical situations, which can happen, for example, when derating requirements are not observed, ambient temperature is too high, ventilation is obstructed, or the derating requirements for different mounting orientation is not followed. There is no correlation between the operating temperature and turn-off temperature, because this is dependent on input voltage, load, and installation methods.
Input transient protection	MOV (Metal Oxide Varistor)	For protection values see section 15 (EMC).
Internal input fuse	Included	Not user replaceable slow-blow high-breaking capacity fuse

18. SAFETY FEATURES

Input / output separation	Double or reinforced galvanic isolation	
	SELV	IEC/EN 60950-1
	PELV	IEC/EN 60204-1, EN 62477-1, IEC 60364-4-41



Class of protection	I	PE (Protective Earth) connection required
Isolation resistance	> 500 MOhm	At delivered condition between input and output, measured with 500 Vdc
	> 500 MOhm	At delivered condition between input and PE, measured with 500 Vdc
	> 500 MOhm	At delivered condition between output and PE, measured with 500 Vdc
	> 500 MOhm	At delivered condition between output and DC-OK contacts, measured with 500 Vdc
PE resistance	< 0.1 Ohm	Resistance between PE terminal and the housing in the area of the DIN rail mounting bracket.
Touch current (leakage current)	Typ. 0.14 mA/0.36 mA	At 100 Vac, 50 Hz, TN-, TT-mains/IT-mains
	Typ. 0.20 mA/0.50 mA	At 120 Vac, 60 Hz, TN-, TT-mains/IT-mains
	Typ. 0.33 mA/0.86 mA	At 230 Vac, 50 Hz, TN-, TT-mains/IT-mains
	Max. 0.18 mA/0.43 mA	At 110 Vac, 50 Hz, TN-, TT-mains/IT-mains
	Max. 0.26 mA/0.61 mA	At 132 Vac, 60 Hz, TN-, TT-mains/IT-mains
	Max. 0.44 mA/1.05 mA	At 264 Vac, 50 Hz, TN-, TT-mains/IT-mains

19. DIELECTRIC STRENGTH

The output voltage is floating and has no ohmic connection to the ground. Type and factory tests are conducted by the manufacturer. Field tests may be conducted in the field using the appropriate test equipment which applies the voltage with a slow ramp (2 s up and 2 s down). Connect all input-terminals together as well as all output poles before conducting the test. When testing, set the cut-off current settings to the value in the table below.

Fig. 19-1 Dielectric strength

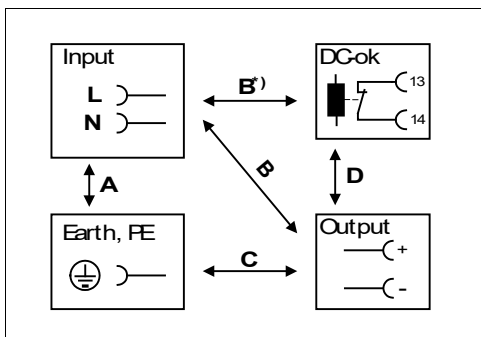

		A	B	C	D
Type test	60 s	2500 Vac	4000 Vac	1000 Vac	500 Vac
Factory test	5 s	2500 Vac	2500 Vac	500 Vac	500 Vac
Field test	5 s	2000 Vac	2000 Vac	500 Vac	500 Vac
Cut-off current setting		> 10 mA	> 10 mA	> 20 mA	> 1 mA

To fulfil the PELV requirements according to EN60204-1 § 6.4.1, we recommend that either the + pole, the – pole, or any other part of the output circuit shall be connected to the protective earth system. This helps to avoid situations in which a load starts unexpectedly or cannot be switched off when unnoticed earth faults occur.

B*) When testing input to DC-OK ensure that the max. voltage between DC-OK and the output is not exceeded (column D). We recommend connecting DC-OK pins and the output pins together when performing the test.

20. APPROVED, FULFILLED OR TESTED STANDARDS

UL 508		UL Certificate Listed equipment for category NMTR - Industrial Control Equipment Applicable for US and Canada E-File: E330187
Class 1 Div 2		UL Certificate Listed equipment for category NRAD - Listed equipment Industrial Control Equipment for Use in Hazardous Locations Applicable for US and Canada E-File: E536050 Temperature Code: T4 Groups: A, B, C and D



IEC 61558-2-16

Safety ✓

Test Certificate
IEC 61558-2-16 - Safety of transformers, reactors, power supply units and similar products for supply voltages up to 1100 V
Particular requirements and tests for switch mode power supply units and transformers for switch mode power supply units

SEMI 47

SEMI F47

Test Report
Voltage Sag Immunity for Semiconductor Processing Equipment
Tested for AC 208 V L-L or L-N mains voltages, nominal output voltage and nominal output load

IEC 60068-2-60

Corrosion
IEC 60068-2-60
Method 4 ✓

Manufacturer's Declaration (Online Document)
Environmental Tests, Flowing Mixed Gas Corrosion Test
IEC 60068-2-60 Method 4
Test Ke - Method 4
H2S: 10 ppb
NO2: 200 ppb
Cl2: 10 ppb
SO2: 200 ppb
Test Duration: 3 weeks, this simulates a service life of 10 years

ISA-71.04 G3

Corrosion
G3-ISA-71.04 ✓

Manufacturer's Declaration (Online Document)
Airborne Contaminants Corrosion Test
ISA-71.04 G3
Severity Level: G3 Harsh
H2S: 100 ppb
NOx: 1250 ppb
Cl2: 20ppb
SO2: 300 ppb
Test Duration: 3 weeks, this simulates a service life of 10 years

Labs

LABS
VDMA 24364-C1-L/W

Paint Wetting Impairment Substances Test (or LABS-Test)
Tested for Zone 2 and test class C1 according to VDMA 24364-C1-L/W for solvents and water-based paints

21. REGULATORY PRODUCT COMPLIANCE

EU Declaration of Conformity



The CE mark indicates conformance with the
- EMC directive
- Low voltage directive
- RoHS directive

REACH Regulation (EU)

REACH ✓

Manufacturer's Declaration
EU regulation regarding the Registration, Evaluation, Authorisation, and Restriction of Chemicals (REACH) fulfilled.
EU Regulation (EC) 1907/2006.

WEEE Regulation



Manufacturer's Declaration
EU Regulation on Waste Electrical and Electronic Equipment
Registered as business to business (B2B) products.
EU Regulation 2012/19/EU

UKCA



UKCA Declaration of Conformity
Trade conformity assessment for England, Scotland, and Wales
The UKCA mark indicates conformity with the UK Statutory Instruments
2016 No.1101,
2016 No.1091,
2012 No.3032

22. PHYSICAL DIMENSIONS AND WEIGHT

Width	39 mm
Height	124 mm
Depth	117 mm
	The DIN rail depth must be added to the unit depth to calculate the total required installation depth.
Weight	600 g
DIN rail	Use 35 mm DIN rails according to EN 60715 or EN 50022 with a height of 7.5 or 15 mm.
Housing material	Body: Aluminium alloy Cover: Zinc-plated steel
Installation clearances	See section 2

Fig. 22-1
Front view

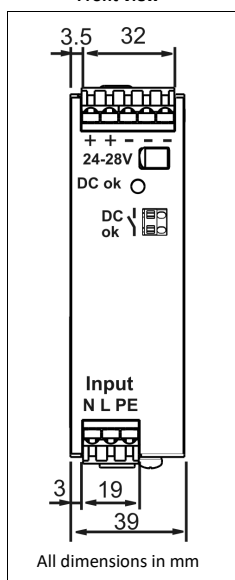
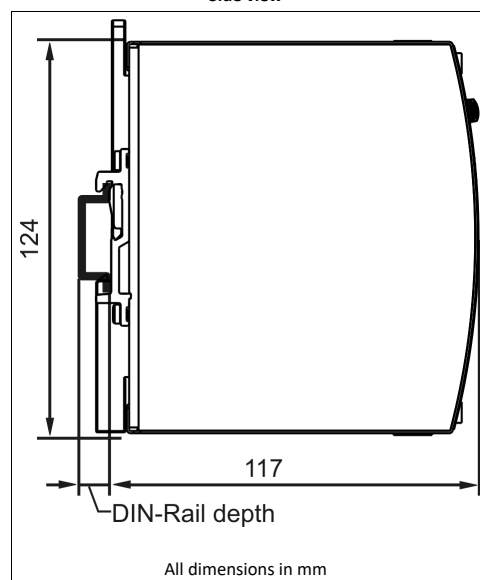
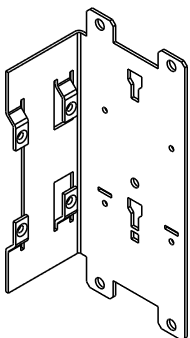

Fig. 22-3
Side view



23. ACCESSORIES

23.1. SIDE MOUNTING BRACKET—139683-01



This bracket is used to mount the power supply sideways with or without using a DIN rail.

The two aluminum brackets and the black plastic slider of the unit have to be detached, so that the steel brackets can be mounted.

For sideways DIN rail mounting, the removed aluminum brackets and the black plastic slider need to be mounted on the steel bracket.

Fig. 23-1
Side mounting without DIN rail brackets

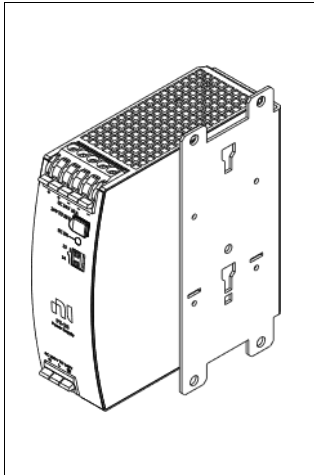

Fig. 23-2
Side mounting with DIN rail brackets

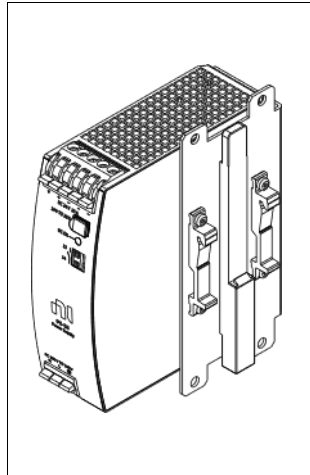
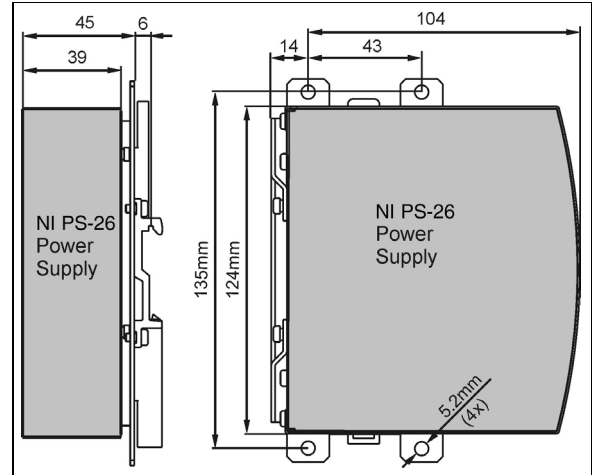

Fig. 23-3
Mounting Dimensions
Side mounting bracket



24. APPLICATION NOTES

24.1. PEAK CURRENT CAPABILITY

The unit can deliver peak currents (up to several milliseconds) which are higher than the specified short term currents.

This helps to start current demanding loads. Solenoids, contactors and pneumatic modules often have a steady state coil and a pick-up coil. The inrush current demand of the pick-up coil is several times higher than the steady-state current and usually exceeds the nominal output current (including the PowerBoost). The same situation applies when starting a capacitive load.

The peak current capability also ensures the safe operation of subsequent circuit breakers of load circuits. The load branches are often individually protected with circuit breakers or fuses. In case of a short or an overload in one branch circuit, the fuse or circuit breaker need a certain amount of over-current to open in a timely manner. This avoids voltage loss in adjacent circuits.

The extra current (peak current) is supplied by the power converter and the built-in large sized output capacitors of the power supply. The capacitors get discharged during such an event, which causes a voltage dip on the output. The following two examples show typical voltage dips for resistive loads:

Fig. 24-1 20 A peak current for 50 ms , typ.
(2x the nominal current)

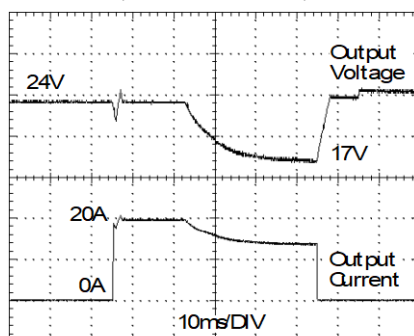

Fig. 24-2 50 A peak current for 5 ms , typ.
(5x the nominal current)

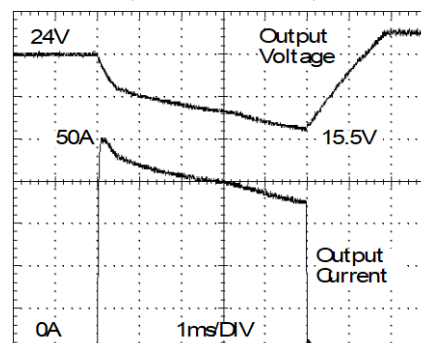
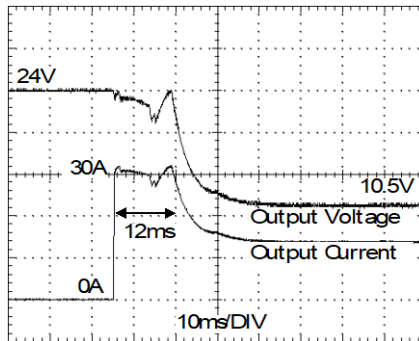

Fig. 24-3 30 A peak current for 12 ms , typ.
(3x the nominal current)



Please note: The DC-OK relay triggers when the voltage dips more than 10% for longer than 1 ms.

Peak current voltage dips	Typically from 24 V to 17 V	At 20 A for 50 ms, resistive load
	Typically from 24 V to 19 V	At 50 A for 2 ms, resistive load
	Typically from 24 V to 15.5 V	At 50 A for 5 ms, resistive load

24.2. BACK-FEEDING LOADS

Loads such as decelerating motors and inductors can feed voltage back to the power supply. This feature is also called return voltage immunity or resistance against Back- E.M.F. (Electro Magnetic Force).

This power supply is resistant and does not show malfunctioning when a load feeds back voltage to the power supply. It does not matter whether the power supply is on or off.

The maximum allowed feed-back-voltage is 35 Vdc. The maximum allowed feed-back peak current is 40 A. Higher currents can temporarily shut-down the output voltage. The absorbing energy can be calculated according to the built-in large sized output capacitor which is specified in section 6.

24.3. EXTERNAL INPUT PROTECTION

The unit is tested and approved for branch circuits up to 30 A (UL) and 32 A (IEC). An external protection is only required if the supplying branch has an ampacity greater than this. Check also local codes and local requirements. In some countries local regulations might apply.

If an external fuse is necessary or utilized, minimum requirements need to be considered to avoid nuisance tripping of the circuit breaker. A minimum value of 6A B- or C-Characteristic breaker should be used.

24.4. OUTPUT CIRCUIT BREAKERS

Standard miniature circuit breakers (MCB's or UL 1077 circuit breakers) are commonly used for AC-supply systems and may also be used on 24 V branches.

MCB's are designed to protect wires and circuits. If the ampere value and the characteristics of the MCB are adapted to the wire size that is used, the wiring is considered as thermally safe regardless of whether the MCB opens or not.

To avoid voltage dips and under-voltage situations in adjacent 24 V branches which are supplied by the same source, a fast (magnetic) tripping of the MCB is desired. A quick shutdown within 10 ms is necessary corresponding roughly to the ride-through time of PLCs. This requires power supplies with high current reserves and large output capacitors. Furthermore, the impedance of the faulty branch must be sufficiently small for the current to actually flow. The best current reserve in the power supply does not help if Ohm's law does not

permit current flow. The following table has typical test results showing which B- and C-Characteristic MCBs magnetically trip depending on the wire cross section and wire length.

Fig. 24-4 Test circuit

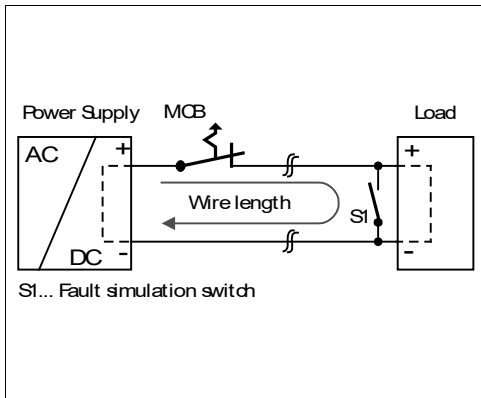

Maximal wire length* for a fast (magnetic) tripping:

	0.75 mm ²	1.0 mm ²	1.5 mm ²	2.5 mm ²
C-2A	30 m	37 m	54 m	84 m
C-3A	25 m	30 m	46 m	69 m
C-4A	9 m	15 m	25 m	34 m
C-6A	3 m	3 m	4 m	7 m
C-8A				
B-6A	12 m	15 m	21 m	34 m
B-10A	3 m	3 m	4 m	9 m
B-13A	2 m	2 m	3 m	6 m

* Don't forget to consider twice the distance to the load (or cable length) when calculating the total wire length (+ and - wire).

24.5. SERIES OPERATION

Power supplies of the same type can be connected in series for higher output voltages. It is possible to connect as many units in series as needed, providing the sum of the output voltage does not exceed 150 Vdc. Voltages with a potential above 60 Vdc are not SELV anymore and can be dangerous. Such voltages must be installed with a protection against touching.

Earthing of the output is required when the sum of the output voltage is above 60 Vdc.

Avoid return voltage (for example, from a decelerating motor or battery) which is applied to the output terminals.

Restrictions:

Keep an installation clearance of 15 mm (left/right) between two power supplies and avoid installing the power supplies on top of each other.

Do not use power supplies in series in mounting orientations other than the standard mounting orientation (terminals on bottom of the unit).

Pay attention that leakage current, EMI, inrush current, harmonics will increase when using multiple power supplies.

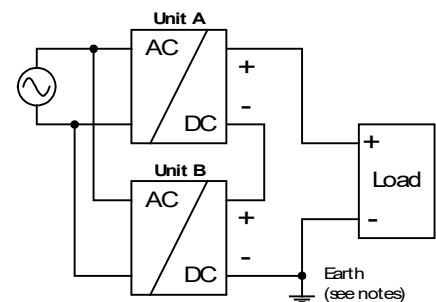

24.6. PARALLEL USE TO INCREASE OUTPUT POWER

NI PS-26 power supplies can be paralleled to increase the output power. The output voltage of all power supplies shall be adjusted to the same value (± 100 mV) with the same load conditions on all units, or the units can be left with the factory settings. There is no feature included which balances the load current between the power supplies. Usually the power supply with the higher adjusted output voltage draws current until it goes into current limitation. This means no harm to this power supply as long as the ambient temperature stays below 40 °C.

If more than three units are connected in parallel, a fuse or circuit breaker with a rating of 15 A or 16 A is required on each output. Alternatively, a diode or redundancy module can also be utilized.

Energize all units at the same time to avoid the overload Hiccup^{PLUS} mode. It also might be necessary to cycle the input power (turn-off for at least five seconds) if the output was in Hiccup^{PLUS} mode due to overload or short circuits and the required output current is higher than the current of one unit.

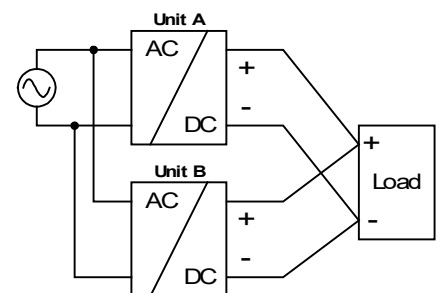



Restrictions:

Keep an installation clearance of 15 mm (left/right) between two power supplies and avoid installing the power supplies on top of each other.

Do not use power supplies in parallel in mounting orientations other than the standard mounting orientation (terminals on bottom of the unit) or in any other condition where a derating of the output current is required (for example, altitude).

Pay attention that leakage current, EMI, inrush current, and harmonics will increase when using multiple power supplies.

24.7. PARALLEL USE FOR REDUNDANCY

1+1 Redundancy:

Power supplies can be paralleled for redundancy to gain higher system availability. Redundant systems require a certain amount of extra power to support the load in case one power supply unit fails. The simplest way is to put two power supplies in parallel. This is called a 1+1 redundancy. In case one power supply unit fails, the other one is automatically able to support the load current without any interruption. It is possible that the defective unit will become a load of another power supply while configured in parallel usage.

Recommendations for building redundant power systems:

- Use separate input fuses for each power supply.
- Monitor the individual power supply units. Therefore, use the DC-OK relay contact of the power supply.
- It is desirable to set the output voltages of all units to the same value (± 100 mV) or leave it at the factory setting.

Pay attention that leakage current, EMI, inrush current, harmonics will increase when using multiple power supplies.

N+1 Redundancy:

Redundant systems for a higher power demand are usually built in a N+1 method. For example, four power supplies, each rated for 10 A are paralleled to build a 30 A redundant system.

Pay attention that leakage current, EMI, inrush current, harmonics will increase when using multiple power supplies.

Keep an installation clearance of 15 mm (left/right) between two power supplies and avoid installing the power supplies on top of each other.

Do not use power supplies in parallel in mounting orientations other than the standard mounting orientation or in any other condition, where a derating of the output current is required.

Inductive and Capacitive Loads

The unit is designed to supply any kind of loads, including capacitive and inductive loads. If extreme large capacitors, such as EDLCs (electric double layer capacitors or "UltraCaps") with a capacitance larger than 1.5 F are connected to the output, the unit might charge the capacitor in the Hiccup^{PLUS} mode (see section 6).

24.8. CHARGING OF BATTERIES

The power supply can be used to charge lead-acid or maintenance free batteries (SLA or VRLA batteries). Two 12 V batteries are needed in series.

Instructions for charging batteries:

- Ensure that the ambient temperature of the power supply stays below 40 °C for mains voltage of AC 120 V or higher and 35 °C for a mains voltage of AC 100 V.
- Set output voltage (measured at no load and at the battery end of the cable) very precisely to the end-of-charge voltage.

End-of-charge voltage	27.8 V	27.5 V	27.15 V	26.8 V
Battery temperature	10 °C	20 °C	30 °C	40 °C

- Use a 15 A or 16 A circuit breaker (or blocking diode) between the power supply and the battery.
- Ensure that the output current of the power supply is below the allowed charging current of the battery.

- e) Use only matched batteries when putting 12 V types in series.
- f) The return current to the power supply (battery discharge current is typ. 3.5 mA when the power supply is switched off (except in case a blocking diode is utilized)).

24.9. OPERATION ON TWO PHASES

The power supply can also be used on two-phases of a three-phase-system. Such a phase-to-phase connection is allowed as long as the supplying voltage is below 240 V^{+10%}.

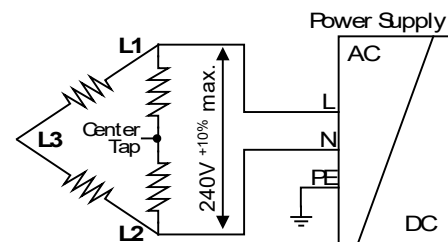

24.10. USE IN A TIGHTLY SEALED ENCLOSURE

When the power supply is installed in a tightly sealed enclosure, the temperature inside the enclosure will be higher than outside. In such situations, the inside temperature defines the ambient temperature for the power supply.

The following measurement results can be used as a reference to estimate the temperature rise inside the enclosure.

The power supply is placed in the middle of the box, no other heat producing items are inside the box.

The temperature sensor inside the box is placed in the middle of the right side of the power supply with a distance of 1 cm.

	Case A	Case B	Case C	Case D
Enclosure size	110 x 180 x 165 mm Rittal Typ IP66 Box PK 9516 100, plastic	110 x 180 x 165 mm Rittal Typ IP66 Box PK 9516 100, plastic	180 x 180 x 165 mm Rittal Typ IP66 Box PK 9519 100, plastic	180 x 180 x 165 mm Rittal Typ IP66 Box PK 9519 100, plastic
Input voltage	230 Vac	230 Vac	230 Vac	230 Vac
Load	24 V, 8 A; (= 80%)	24 V, 10 A; (= 100%)	24 V, 8 A; (= 80%)	24 V, 10 A; (= 100%)
Temperature inside the box	48.6 °C	53.8 °C	42.0 °C	48.1 °C
Temperature outside the box	26.3 °C	26.6 °C	25.8 °C	26.2 °C
Temperature rise	22.3 K	27.3 K	16.2 K	21.9 K

24.11. MOUNTING ORIENTATIONS

Mounting orientations other than all terminals on the bottom require a reduction in continuous output power or a limitation in the maximum allowed ambient temperature. The amount of reduction influences the lifetime expectancy of the power supply. Therefore, two different derating curves for continuous operation can be found below:

Curve A1 Recommended output current.

Curve A2 Max allowed output current (results in approximately half the lifetime expectancy of A1).

Fig. 24-5
Mounting
Orientation A
(Standard
orientation)

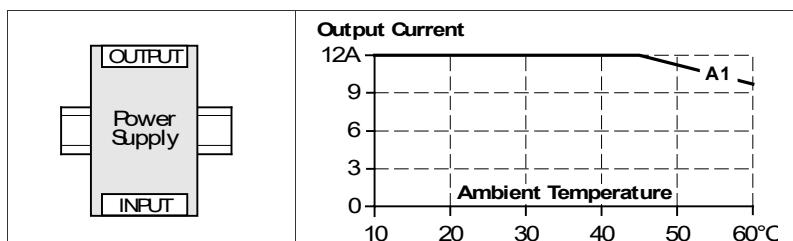

Fig. 24-6
Mounting
Orientation B
(Upside down)

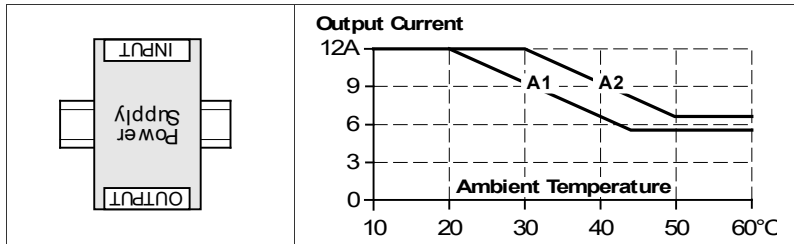

Fig. 24-7
Mounting
Orientation C
(Table-top mounting)

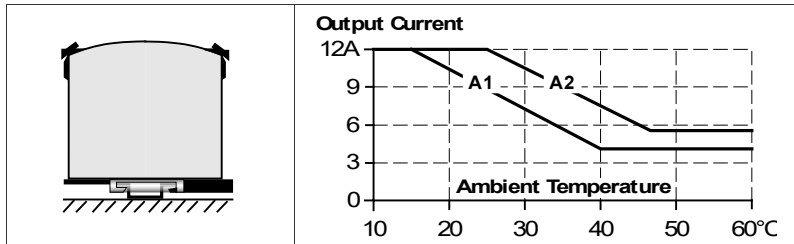

Fig. 24-8
Mounting
Orientation D
(Horizontal cw)

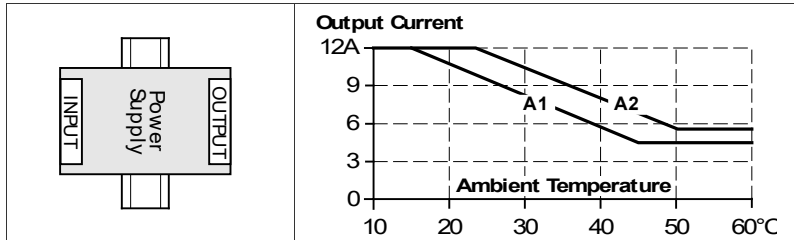

Fig. 24-9
Mounting
Orientation E
(Horizontal ccw)

