

M50 SERIES

POWER MODULES



Features

- Over 40 kW output capability
- 4 Different Circuits to Choose from
- 50 and 100 A outputs
- UL Recognized E72445

SPECIFICATIONS

Part Number	Symbol	M5050	M50100
Maximum DC Output Current (Tc= 85°C)	I_D	50 A	100 A
Maximum Voltage Drop @ Amps Peak	V_F	1.35V @ 50A	1.2V @ 100 A
Operating Junction Temperature Range	T_J	-40 - 125°C	-40 - 125°C
Repetitive Peak Reverse Voltage (AC Line Nominal) [Vpk]	V_{RMS}	600 (240 VAC)	
		800 (280 VAC)	
		1200 (480 VAC)	
Maximum Non-Repetitive Surge Current (1/2 Cycle, 60 Hz) [A]	I_{TSM}	800	1500
Maximum $I^2 t$ for Fusing (t=8.3ms)[A ² sec]	$I^2 t$	2650	9350
Maximum Thermal Resistance, Junction to Ceramic Base per Chip [°C/W]	R_{JC}	0.45°C/W	0.3°C/W
Isolation Voltage [Vrms]	V_{ISOL}	2500	
Weight (typical)		4.5 oz (158g)	

MECHANICAL SPECIFICATIONS

Tolerances: ±0.02 in / 0.5 mm
All dimensions are in: inches [millimeters]

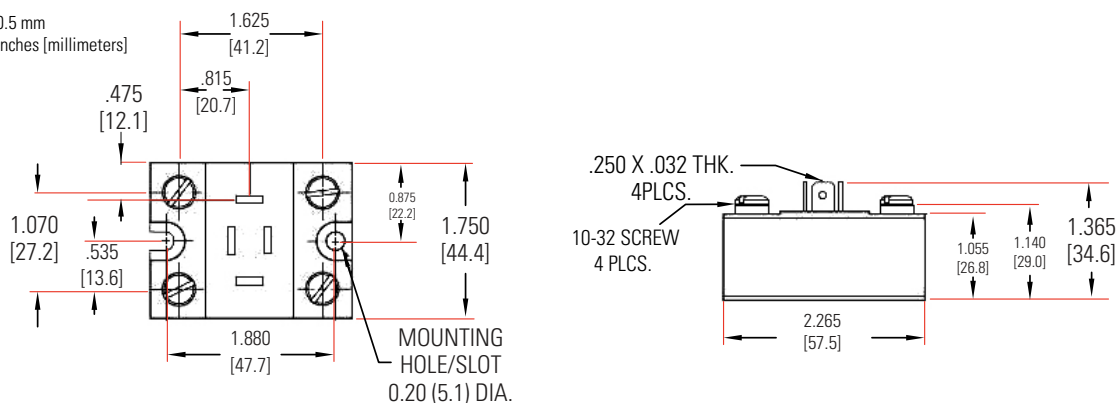

CIRCUIT DIAGRAMS

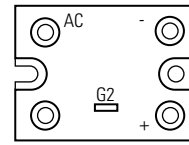
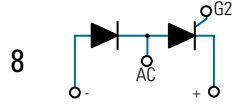
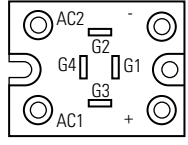
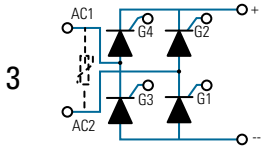
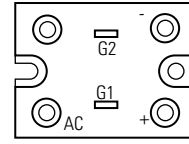
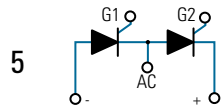
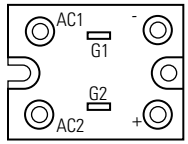
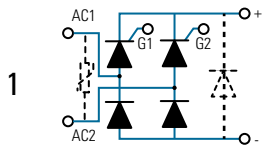

ORDERING OPTIONS

Example : M505012FV

	M50	50	1	2	F	V
Series	[Line connecting M50 to Series]					
M50	[Shaded bar]					
Load Current	[Line connecting 50 to Load Current]					
50: 50 Amps 100: 100 Amps	[Shaded bar]					
Circuit Type	[Line connecting 1 to Circuit Type]					
1 3 5 8 (See schematic diagrams)	[Shaded bar]					
AC Line Voltage	[Line connecting 2 to AC Line Voltage]					
2: 240 VAC 3: 280 VAC 5: 480 VAC	[Shaded bar]					
Free Wheeling Diode	[Line connecting F to Free Wheeling Diode]					
Blank: Not Included F: Included (Circuit 1 only)	[Shaded bar]					
External Suppressor	[Line connecting V to External Suppressor]					
Blank: Not included V: Include (Circuits 1 & 3 only)	[Shaded bar]					

— Required for valid part number
 For options only and not required for valid part number

NOTE: Not all combinations are available. Consult factory for information on the availability of a specific part number.

AGENCY APPROVALS & CERTIFICATIONS



WARNINGS



RISK OF MATERIAL DAMAGE AND HOT ENCLOSURE

- The product's side panels may be hot, allow the product to cool before touching
- Follow proper mounting instructions including torque values
- Do not allow liquids or foreign objects to enter this product

Failure to follow these instructions can result in serious injury, or equipment damage.



HAZARD OF ELECTRIC SHOCK, EXPLOSION OR ARC FLASH

- Disconnect all power before installing or working with this equipment
- Verify all connections and replace all covers before turning on power

Failure to follow these instructions will result in death or serious injury.

Datasheets provided by Sensata Technologies, Inc., its subsidiaries and/or affiliates ("Sensata") are solely intended to assist third parties ("Buyers") who are developing systems that incorporate Sensata products (also referred to herein as "components"). Buyer understands and agrees that Buyer remains responsible for using its independent analysis, valuation, and judgment in designing Buyer's systems and products. Sensata datasheets have been created using standard laboratory conditions and engineering practices. Sensata has not conducted any testing other than that specifically described in the published documentation for a particular datasheet. Sensata may make corrections, enhancements, improvements, and other changes to its datasheets or components without notice.

Buyers are authorized to use Sensata datasheets with the Sensata component(s) identified in each particular datasheet. HOWEVER, NO OTHER LICENSE, EXPRESS OR IMPLIED, BY ESTOPPEL OR OTHERWISE TO ANY OTHER SENSATA INTELLECTUAL PROPERTY RIGHT, AND NO LICENSE TO ANY THIRD PARTY TECHNOLOGY OR INTELLECTUAL PROPERTY RIGHT, IS GRANTED HEREIN. SENSATA DATASHEETS ARE PROVIDED "AS IS". SENSATA MAKES NO WARRANTIES OR REPRESENTATIONS WITH REGARD TO THE DATASHEETS OR USE OF THE DATASHEETS, EXPRESS, IMPLIED, OR STATUTORY, INCLUDING ACCURACY OR COMPLETENESS. SENSATA DISCLAIMS ANY WARRANTY OF TITLE AND ANY IMPLIED WARRANTIES OF MERCHANTABILITY, FITNESS FOR A PARTICULAR PURPOSE, QUIET ENJOYMENT, QUIET POSSESSION, AND NON-INFRINGEMENT OF ANY THIRD PARTY INTELLECTUAL PROPERTY RIGHTS WITH REGARD TO SENSATA DATASHEETS OR USE THEREOF.

All products are sold subject to Sensata's terms and conditions of sale supplied at www.sensata.com. SENSATA ASSUMES NO LIABILITY FOR APPLICATIONS ASSISTANCE OR THE DESIGN OF BUYERS' PRODUCTS. BUYER ACKNOWLEDGES AND AGREES THAT IT IS SOLELY RESPONSIBLE FOR COMPLIANCE WITH ALL LEGAL, REGULATORY, AND SAFETY-RELATED REQUIREMENTS CONCERNING ITS PRODUCTS, AND ANY USE OF SENSATA COMPONENTS IN ITS APPLICATIONS, NOTWITHSTANDING ANY APPLICATIONS-RELATED INFORMATION OR SUPPORT THAT MAY BE PROVIDED BY SENSATA.

Mailing Address: Sensata Technologies, Inc., 529 Pleasant Street, Attleboro, MA 02703, USA

CONTACT US

Americas

+1 (877) 502 5500 – Option 2
sales.crydom@sensata.com

Europe, Middle East & Africa

+44 (1202) 416170
ssr-info.eu@sensata.com

Asia Pacific

sales.isasia@list.sensata.com
China +86 (21) 2306 1500

Japan +81 (45) 277 7117

Korea +82 (31) 601 2004

India +91 (80) 67920890

Rest of Asia +886 (2) 27602006
ext 2808