

Features

- Support DALI-2+pushDIM+pushCCT control
- Support advanced functions such as corridor dim, EL, CLO
- Suitable for emergency lighting acc. to EN 50172
- 10-level current output can be realized through external DIP-switch, easier to adjust the luminaire power
- Soft dimming and flicker-free at any brightness, meets the new requirements of ErP certification
- Using HPC patented technology, at any dimming level, the current output between drivers is the same
- Dimming range 1%-100%, output current accuracy 1%
- Standby power input<0.5W, meets the requirements of ErP certification
- High PF, high efficiency, low THD
- Intelligent LED hot-plug protection function
- SELV and Class II design, suitable for use outside of the light
- IP20 protection grade, indoor use
- Nominal life-time up to 50,000 h

Interfaces

- DALI-2(DALI-2 DT8)
- PUSH(PUSH-DIM, corridorFUNCTION)
- PUSH(PUSH-CCT)

Functions

- PUSH-CCT with memory function(PUSH)
- Corridor function mode(CF)
- Suitable for emergency lighting(EL)
- Protective features (short-circuit, overload, no-load, hot plug-in protection)

Suitable for lights

- Suitable for linear lights, tri-proof lights, working lights and other linear or ultra-thin lights etc.

Typical applications

- LED indoor lighting
- LED office lighting
- LED commercial lighting

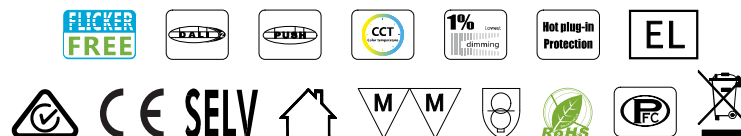

- Dimmable Constant current 2-Channel LED driver with DALI DT8
- Support DALI dimming and tunable white function
- Support PUSH dimming and tunable white function
- Dimming range 1 to 100%
- Tunable White
- Output Wattage : 63W Max
- Output voltage range of 12-42Vdc
- Output Current: 1050 - 1500mA
- Flicker-free at any brightness, meeting the standard of flicker-free(IEEE 1789-2015)
- Application
 - LED indoor lighting
 - LED office lighting
 - LED architectural lighting
 - LED panel lamp lighting

General Specifications

Rated Input Voltage	200-240Vac,50/60Hz
Operating Input Voltage Range	180-264Vac,50/60Hz
Input Current	<0.4 @ 230Vac
Input Power	72W
Power Factor	>0.95 @ 230Vac/Full Load
THD	<10% @ 230Vac/Full Load
Efficiency (Typical)	89%
Driver Type	Constant Current DALI-2
Output Current	1500mA ±3%, 1450mA ±3%, 1400mA ±3%, 1350mA ±3%, 1300mA ±3%, 1250mA ±3% 1200mA ±3%, 1150mA ±3%, 1100mA ±3%, 1050mA ±3% *Refer DIP switch Table for O/P current selection
Output Voltage Range	12-42Vdc
Output Power	63W
Number of Output Channels	2 Channel
Output Type	Class II
Dimming Controller Type	DALI-2
Ambient Operating Temperature Range	-20°C to 45°C
Max. Case Temperature	90°C
Input Surge Protection	2KV/2KV
Protections	Input Over Current : Non Resettable (Fuse) Output Short Circuit : Auto Recovery (HICCUP Mode) Output Open Circuit : Auto Recovery (HICCUP Mode) Output Overload : YES Over Temperature : Auto Recovery (HICCUP Mode)
Certification and Standards	EN61347-1, EN61347-2-13, GB19510.1/14, En62384 EN55015, EN61000-3-2, EN61000-3-3, EN61000-4-2,3,4,5,6,8,11, EN61547 EN62386-101(DALI-2), EN62386-102(DALI-2),, EN62386-207(DALI-2)
Withstand Voltage	I/P-O/P:3750Vac, I/P-FG:1750Vac, O/P-FG:1500Vac, I/P DALI:1500Vac
Leakage Current	<0.7mA @ 240Vac
Isolation resistance	I/P-O/P:100MΩ / 500Vdc / 25°C / 70% RH
Life	50,000 Hours @ 80°C
Approvals / Class	SELV Equivalent
Warranty	5 Years
Weight	0.255 Kg

Note : Suitable for Indoor application only

DIP Switch Chart :

Pin	Irated	Voltage	1	2	3	4
50.0W	1050mA	42VDC	--	ON	ON	ON
52.0W	1100mA	42VDC	ON	--	ON	ON
54.5W	1150mA	42VDC	--	--	ON	ON
57.0W	1200mA	42VDC	--	ON	--	ON
59.5W	1250mA	42VDC	--	--	--	ON
61.5W	1300mA	42VDC	ON	ON	ON	--
64.0W	1350mA	42VDC	--	--	ON	--
66.5W	1400mA	42VDC	--	ON	--	--
69.0W	1450mA	42VDC	ON	--	--	--
70.5W	1500mA ★	42VDC	--	--	--	--

Remark: ★ this current is factory default.
 -- this Switch is off.

Operating window

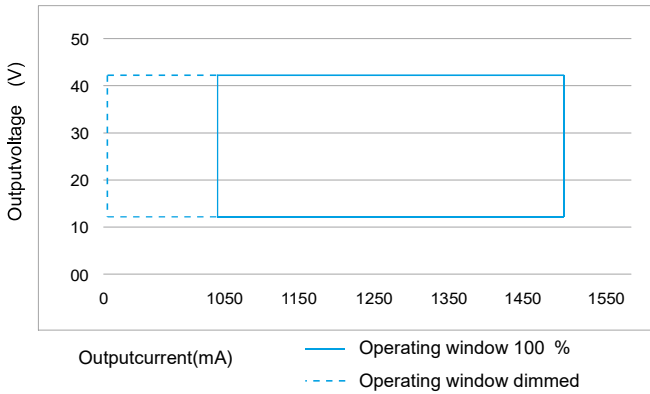

Operating window

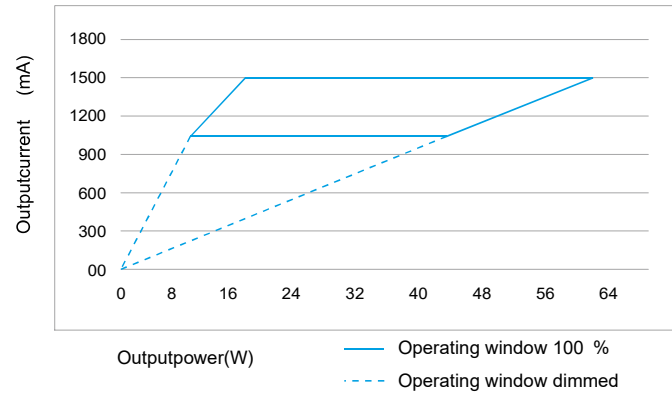

THD vs. Load

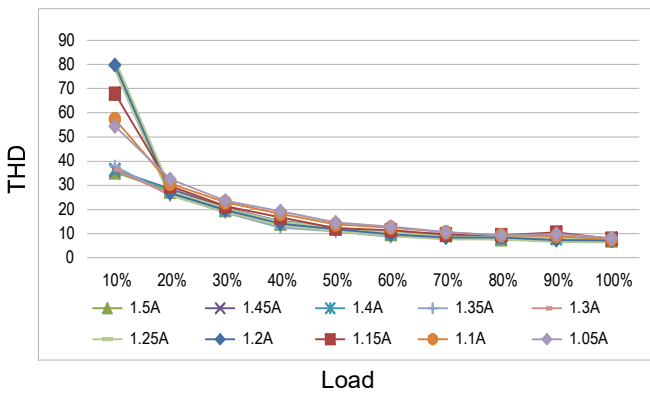

Power factor vs. Load

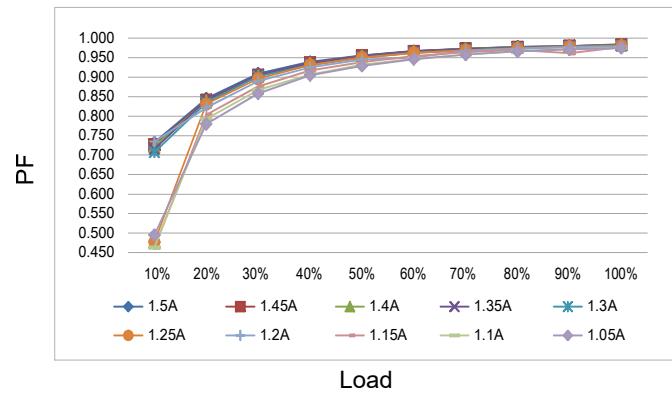

Efficiency vs. Load

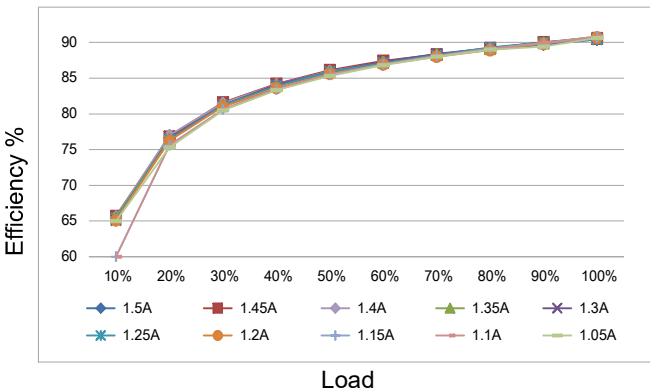

Lifetime vs. case temperature

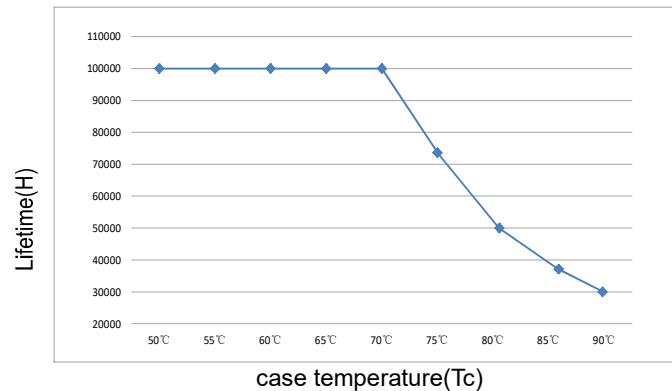

Fulham extends a limited warranty only to the original purchaser or to the first user for a period of **05 years @ Tc 80°C** from the date of manufacture when properly installed and operated under normal conditions of use. For complete terms and conditions, please reference the Fulham Product Catalog (www.fulham.com). Due to a program of continuous improvement, Fulham reserves the right to make modifications or variations in design or construction to the equipment described. © Fulham Company Limited, All Rights Reserved.

DALI dimming application

Wiring diagram

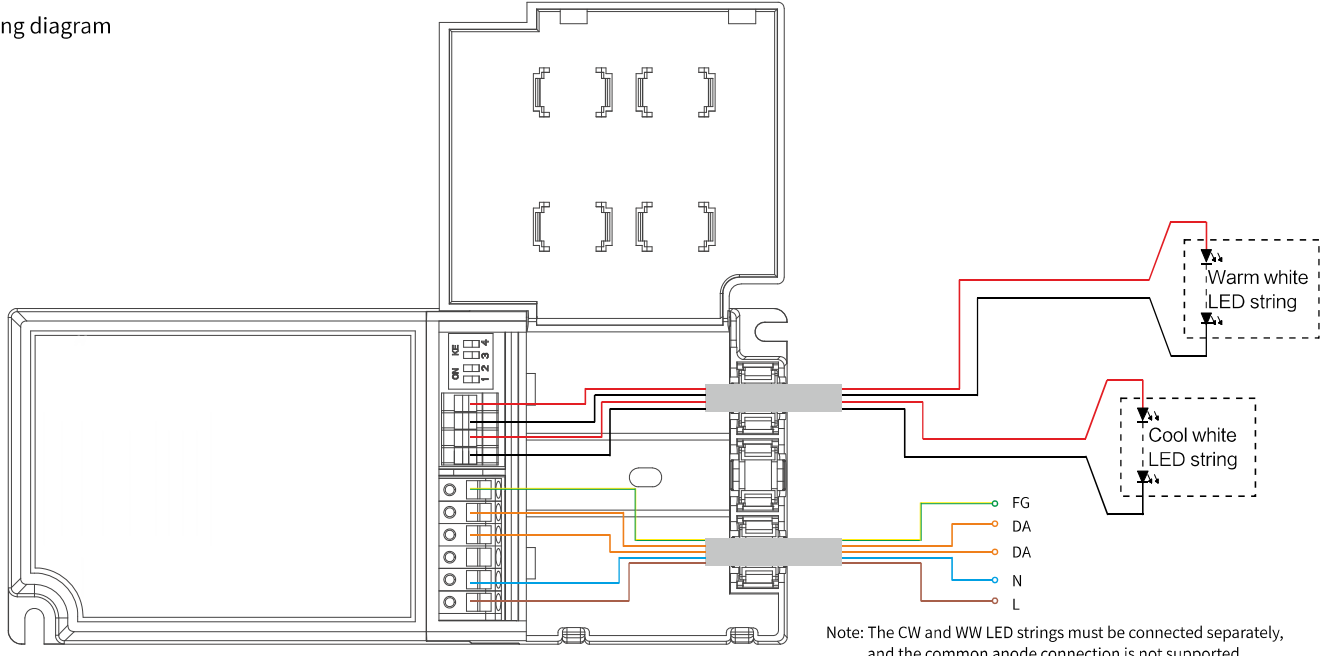

Activating DALI control mode

- After installation according to the wiring diagram of DALI control application, the driver will automatically switch to the DALI control mode after receiving any DALI command.

Remarks:

- Standard DALI control line voltage range: 9.5V to 22.5V, type 16V.
- The two DALI control lines polarity-reversible.
- Max. 64 DALI drivers per DALI control line.
- The maximum distance length of the DALI control line is 300m at $2 \times 1.5\text{mm}^2$.
- DALI bus can be wired together with any mains voltage cables, but separate wiring is recommended.

Wiring distance vs cable size

Cable size	Distance
$2 \times 0.50\text{mm}^2$	max.100m
$2 \times 0.75\text{mm}^2$	max.150m
$2 \times 1.00\text{mm}^2$	max.200m
$\geq 2 \times 1.50\text{mm}^2$	max.300m

Dimming curve

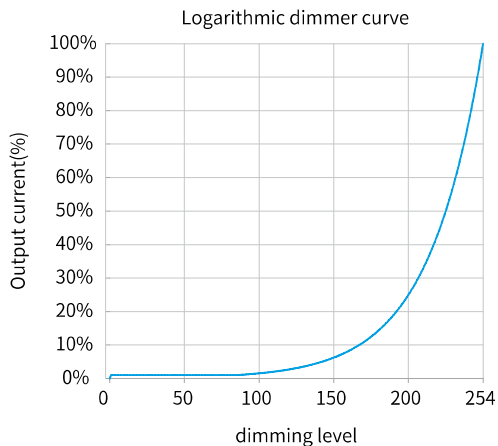

Remarks: The dimming curve can be selected by DALI configuration. The default is logarithmic dimming curve.

Fulham extends a limited warranty only to the original purchaser or to the first user for a period of **05 years @ Tc 80°C** from the date of manufacture when properly installed and operated under normal conditions of use. For complete terms and conditions, please reference the Fulham Product Catalog (www.fulham.com). Due to a program of continuous improvement, Fulham reserves the right to make modifications or variations in design or construction to the equipment described. © Fulham Company Limited, All Rights Reserved.

PUSH dimming application

Wiring diagram

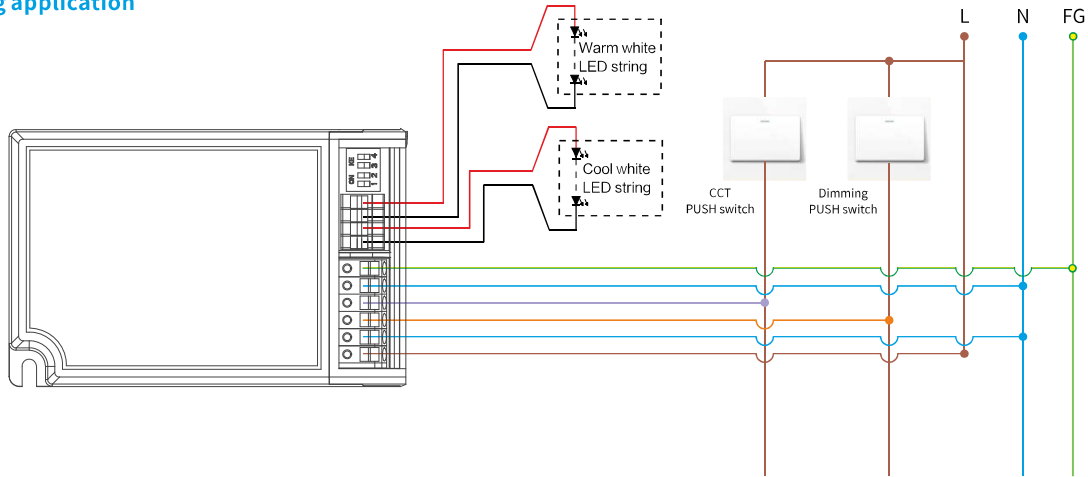

Activating PUSH control mode

- Method 1: After installation according to the wiring diagram of PUSH-DIM control application, short press the PUSH dimming switch(PUSH-DIM port) 5 times within 3 seconds, the driver will automatically switch to PUSH control mode.
- Method 2: Use the configuration tool to set the driver's PUSH control function parameters and turn on the PUSH control function.
- After activating the PUSH control mode, the corridorFUNCTION dimming mode will be automatically deactivate.

Number of mounted drivers

- Up to 50pcs drivers can be mounted.

PUSH dimming switch operating instructions

- Turn on or turn off: short press PUSH dimming switch for 0.2-1s.
- Stepless dimming : long press PUSH dimming switch for 1-6s, Press again to switch dimming directions.

PUSH CCT switch operating instructions

- Switch CCT level: short press PUSH CCT switch for 0.2-1s, 9 levels of preset CCT can be switched.
- Stepless CCT adjustment: long press CCT PUSH switch for 1-6s, Press again to switch CCT adjustment directions.

Power on status:

- After power on,the light state will be the same as the last dimming level and the last CCT level.
- If the light is on before the power is turned off, after turning the power back on, the brightness will be the same as the last time, and the color temperature will be the same as the last time.
- If the light is off before the power is turned off, the light will be turned off after the power is turned back on. You need to press the PUSH-DIM dimming switch for a short time to turn on the light. The brightness after lighting will be the same as the last time, and the color temperature will be the same as the last time.

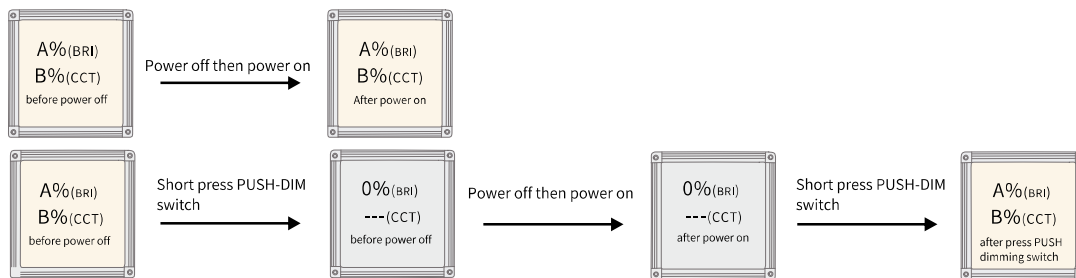

Multiple lights synchronize control operation

- method 1:
- Step 1:long press the PUSH-DIM switch,confirm each light is on.
 - Step 2:short press the PUSH-DIM switch,confirm each light is off.
 - Step 3:long press the PUSH-DIM switch,confirm each light is from darkest to brightest and all the lights are synchronous.
- method 2:
- Long press the PUSH-DIM dimming switch for more than 15s, all drivers will output 100% brightness and the color temperature is natural white (middle of color temperature range).

Fulham extends a limited warranty only to the original purchaser or to the first user for a period of **05 years @ Tc 80°C** from the date of manufacture when properly installed and operated under normal conditions of use. For complete terms and conditions, please reference the Fulham Product Catalog (www.fulham.com). Due to a program of continuous improvement, Fulham reserves the right to make modifications or variations in design or construction to the equipment described. © Fulham Company Limited, All Rights Reserved.

CorridorFUNCTION dimming

Wiring diagram

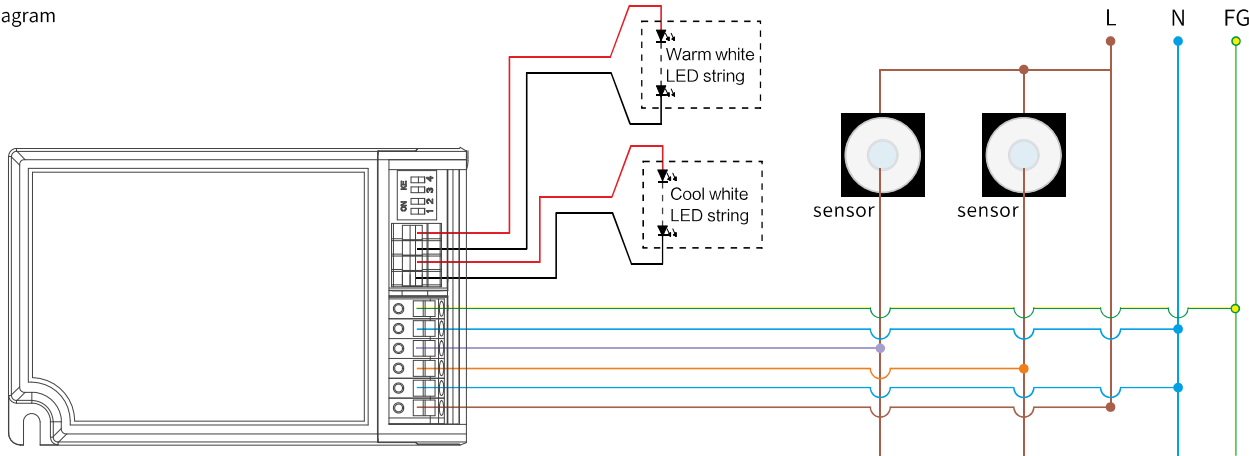

••• Max. x50

Note: The CW and WW LED strings must be connected separately, and the common anode connection is not supported

Activating the CorridorFUNCTION dimming mode

- Method 1: Activating by sensor.

After installation according to the wiring diagram of CorridorFUNCTION dimming application, you can use the following methods to activate.

Method 1: Keep the movement in the effective sensing area for 5 minutes, the CorridorFUNCTION dimming function of the drive will be activated and light up 100% (under the default setting).

Method 2: Activate by Hold-time

Set the hold-time of the sensor to more than 5 minutes. When the motion sensor detects a person and turns on the output for 5 minutes, the CorridorFUNCTION dimming function will be activated and the light will be on 100%(Default), finally restore the hold-time that the sensor actually needs.

-Method 2: Activate by normal switch

After installation according to the wiring diagram of the CorridorFUNCTION dimming application, first replace the sensor with a normal switch, and then turn on the normal switch for 5 minutes, and the driver will automatically switch to CorridorFUNCTION dimming mode, then remove the normal switch and replace it with the sensor.

- Method 3: Use the configuration tool to turn on the driver's CorridorFUNCTION dimming mode and set the parameters.

-After activating the CorridorFUNCTION dimming mode, the PUSH dimming mode will be automatically deactivate .

Remarks

- It is recommended to set the hold-time of the motion sensor to within 5s.

- Need to use a motion sensor with AC switch.

CorridorFUNCTION working process

Brightness level

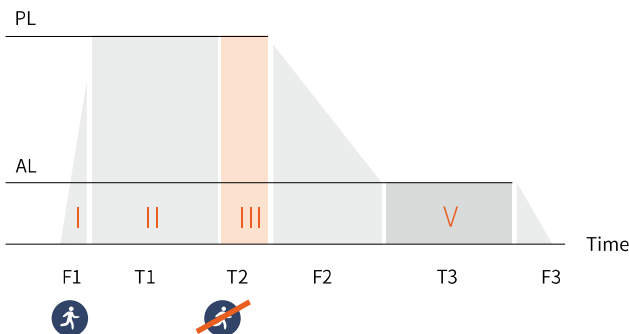

- The parameters of CorridorFUNCTION can be set through the configuration tool.

- CorridorFUNCTION is not activated by default.

Name	Symbol	Factory setting	Settable range
Fade-in time	F1	0s	0-9600s
Presence level	PL	100%	0-100%
Hold-on time	T1	By sensor setting	
Run-on time	T2	120s	0-2500s
Fade-out time	F2	32s	0-9600s
Absence level	AL	10%	0-100%
Stand-by Time	T2	unlimited	0-2540s, unlimited
Fade-off time	F3	0s	0-9600s

Fulham extends a limited warranty only to the original purchaser or to the first user for a period of **05 years @ Tc 80°C** from the date of manufacture when properly installed and operated under normal conditions of use. For complete terms and conditions, please reference the Fulham Product Catalog (www.fulham.com). Due to a program of continuous improvement, Fulham reserves the right to make modifications or variations in design or construction to the equipment described. © Fulham Company Limited, All Rights Reserved.

Mechanical Data :

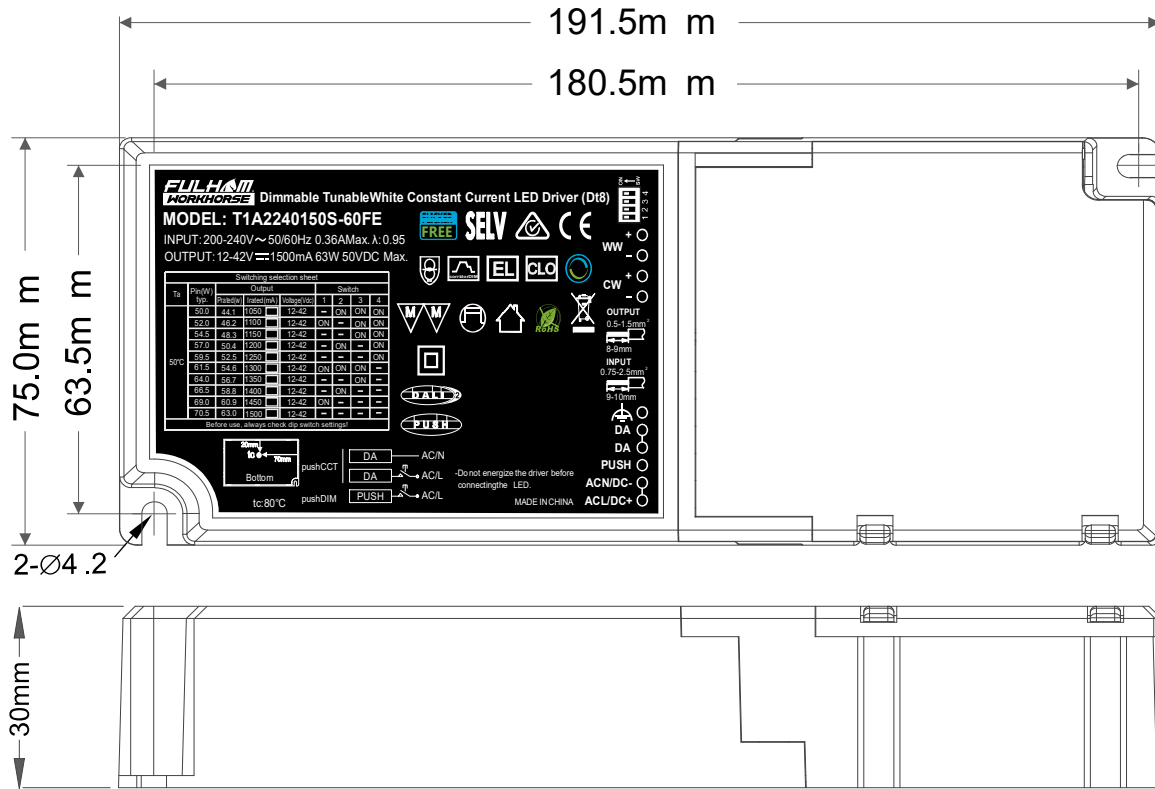

Note : All Dimensions are in mm.

Tolerance=±0.5mm

Packaging

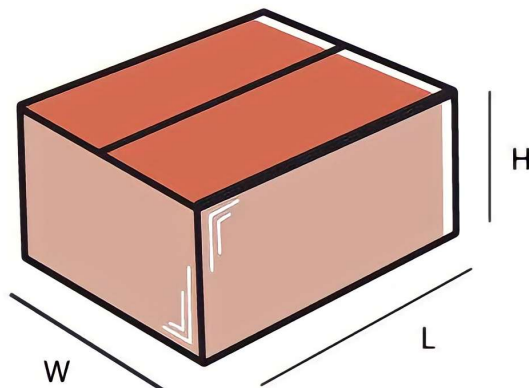

Master carton

OUTER DIMENSION		
L	W	H
465mm	325mm	185mm
Net Weight	Gross Weight	QUANTITY
8.2 kg	10.2 kg	32 pc.

Installation Instructions:

Connect Wires as per details given on the Driver Screen. Keep proper ventilation around the LED Driver and do not stack any object on it. Also a 10-15 cm clearance must be kept when the adjacent device is a heat source. Do not exceed the declared Hot spot temperature(Tc max) under any circumstances.

Fulham extends a limited warranty only to the original purchaser or to the first user for a period of **05 years @ Tc 80°C** from the date of manufacture when properly installed and operated under normal conditions of use. For complete terms and conditions, please reference the Fulham Product Catalog (www.fulham.com). Due to a program of continuous improvement, Fulham reserves the right to make modifications or variations in design or construction to the equipment described. © Fulham Company Limited, All Rights Reserved.