



DQ12 Series Sensor

Original Instructions

p/n: 213155 Rev. C

06-May-25

© Banner Engineering Corp. All rights reserved. www.bannerengineering.com

Contents

Chapter 1 Features	3
Models	3
Chapter 2 Indicator Features	5
Wiring	5
Chapter 3 Specifications	6
FCC Part 15 Class A for Unintentional Radiators	6
Industry Canada ICES-003(A)	7
Dimensions	7
Performance Curves	7
Chapter 4 Accessories	9
Cordsets	9
Brackets	10
Apertures	10
Chapter 5 Product Support and Maintenance	12
Clean with Mild Detergent and Warm Water	12
Repairs	12
Contact Us	12
Banner Engineering Corp Limited Warranty	12

Chapter 1 Features

Miniature self-contained photoelectric sensors in a universal housing

- Bright, visible red (645 nm) light source
- Standard models available with 4-wire, 2 m (6.5 ft) long cable; 150 mm (6 in) PVC-jacketed cable with a 3-pin M8 male quick-disconnect connector; or a 150 mm (6 in) PVC-jacketed cable with a 4-pin M8 male quick-disconnect connector
- Solid-state, bipolar outputs: one current sourcing (PNP) and one current sinking (NPN) standard on 4-wire models
- Single output solid-state PNP or NPN standard on Q3 models
- Light Operate (L.O.) or Dark Operate (D.O.), depending on the model
- Compact 8 mm (0.31 in) housing mounts almost anywhere
- Crosstalk avoidance circuitry for applications with multiple sensors
- LED status indicators for Power ON, Signal Received, and Marginal Signal
- Advanced ASIC technology makes the sensor resistant to optical and electrical noise sources



WARNING:



- **Do not use this device for personnel protection**
- Using this device for personnel protection could result in serious injury or death.
- This device does not include the self-checking redundant circuitry necessary to allow its use in personnel safety applications. A device failure or malfunction can cause either an energized (on) or de-energized (off) output condition.

Models

Sensing Mode	Model	Range ⁽¹⁾	Connection	Output
<p>OPPOSED Effective Beam: 5.7 mm (0.22 in)</p>	DQ126E (emitter)	3 m	2 m (6.5 ft) cable	N/A
	DQ12AB6R		2 m (6.5 ft) cable	Bipolar LO
	DQ12RB6R			Bipolar DO
	DQ12AP6RQ3		150 mm (6 in) cable with a 3-pin M8 QD	1 PNP LO
	DQ12RP6RQ3			1 PNP DO
	DQ12AN6RQ3			1 NPN LO
	DQ12RN6RQ3			1 NPN DO
<p>POLAR RETRO Visible red, 645 nm</p>	DQ12AB6LP	2 m	2 m (6.5 ft) cable	Bipolar LO
	DQ12RB6LP			Bipolar DO
	DQ12AP6LPQ3	150 mm (6 in) cable with a 3-pin M8 QD	1 PNP LO	
	DQ12RP6LPQ3		1 PNP DO	
	DQ12AN6LPQ3		1 NPN LO	
	DQ12RN6LPQ3		1 NPN DO	

Continued on page 4

⁽¹⁾ Retroreflective range is specified using one model **BRT-60X40C** retroreflector. Actual sensing range may be more or less than specified, depending upon efficiency and reflective area of the retroreflector(s) used.

Continued from page 3

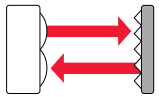
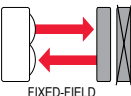
Sensing Mode	Model	Range	Connection	Output
 <p>RETRO Visible red, 645 nm</p>	DQ12AB6LV	3 m	2 m (6.5 ft) cable	Bipolar LO
	DQ12RB6LV			Bipolar DO
	DQ12AP6LVQ3		150 mm (6 in) cable with a 3-pin M8 QD	1 PNP LO
	DQ12RP6LVQ3			1 PNP DO
	DQ12AN6LVQ3			1 NPN LO
	DQ12RN6LVQ3			1 NPN DO
Performance based on the use of a 90% reflectance white test card.				
 <p>FIXED-FIELD VISIBLE RED Visible red, 645 nm</p>	DQ12AB6FF15	15 mm (0.6 in) cutoff; 10 mm (0.4 in) focus	2 m (6.5 ft) cable	Bipolar LO
	DQ12RB6FF15			Bipolar DO
	DQ12AP6FF15Q3		150 mm (6 in) cable with a 3-pin M8 QD	1 PNP LO
	DQ12RP6FF15Q3			1 PNP DO
	DQ12AN6FF15Q3			1 NPN LO
	DQ12RN6FF15Q3			1 NPN DO
	DQ12AB6FF30	30 mm (1.2 in) cutoff; 16 mm (0.63 in) focus	2 m (6.5 ft) cable	Bipolar LO
	DQ12RB6FF30			Bipolar DO
	DQ12AP6FF30Q3		150 mm (6 in) cable with a 3-pin M8 QD	1 PNP LO
	DQ12RP6FF30Q3			1 PNP DO
	DQ12AN6FF30Q3			1 NPN LO
	DQ12RN6FF30Q3			1 NPN DO
	DQ12AB6FF50	50 mm (2 in) cutoff; 16 mm (0.63 in) focus	2 m (6.5 ft) cable	Bipolar LO
	DQ12RB6FF50			Bipolar DO
	DQ12AP6FF50Q3		150 mm (6 in) cable with a 3-pin M8 QD	1 PNP LO
	DQ12RP6FF50Q3			1 PNP DO
	DQ12AN6FF50Q3			1 NPN LO
	DQ12RN6FF50Q3			1 NPN DO

- To order the 9 m (30 ft) cable model, add the suffix **W/30** to the model number. For example, **DQ126E W/30**.
- To order the 150 mm (6 in) cable with a 4-pin M8 QD model, add the suffix **Q** to the model number. For example, **DQ126EQ**.
- To order the 150 mm (6 in) cable with a 4-pin M12 QD model, add the suffix **Q5** to the model number. For example **DQ126EQ5**.

Chapter 2 Indicator Features



1 - Amber and green LEDs

- Green on: power to sensor is on
- Amber on: received signal
- Amber flashing: marginal signal

Wiring

Emitters have no connection to black and white.

 **CAUTION:** Observe proper ESD precautions (grounding) when connecting QD models.

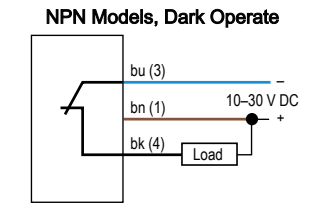
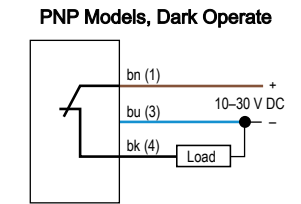
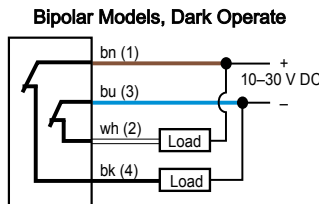
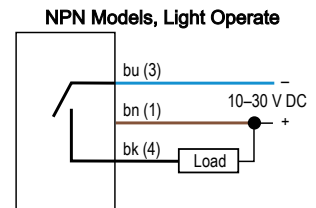
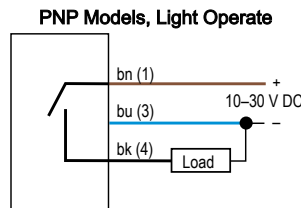
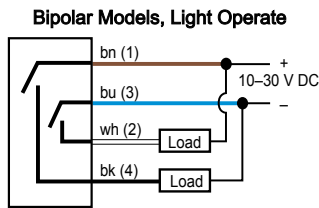
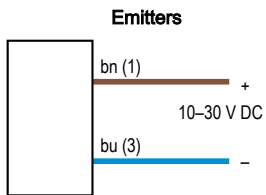

- Key**
- 1 = Brown
 - 2 = White
 - 3 = Blue
 - 4 = Black

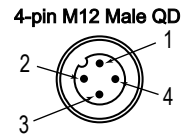
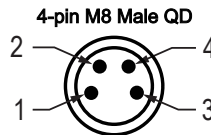
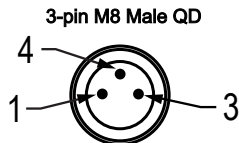

Chapter Contents

FCC Part 15 Class A for Unintentional Radiators..... 6
 Industry Canada ICES-003(A)..... 7
 Dimensions..... 7
 Performance Curves 7

Chapter 3 Specifications

Supply Voltage and Current

10 to 30 V DC (10% maximum ripple) at 20 mA maximum current

Sensing Beam

Visible red, 645 nm

Supply Protection Circuitry

Protected against reverse polarity and transient voltages

Output Configuration

Bipolar (1 NPN and 1 PNP) solid-state output or single output (PNP or NPN), light operate (LO) or dark operate (DO), depending on model

Repeatability

125 microseconds

Switching Frequency

Opposed Mode: 385 Hz
 LP/LV Mode: 715 Hz
 FF Mode: 590 Hz

Output Protection Circuitry

Protected against false pulse on power-up, short-circuit protected

Output Response Time

Opposed Mode: 1.3 ms ON; 900 µs OFF
 LP/LV Mode: 700 µs ON/OFF
 FF Mode: 850 µs ON/OFF
 120 ms delay on power-up; outputs do not conduct during this time

Construction

Polarized Retro Models: Polyamide housing with glass lens
 All Other Models: Polyamide housing with polycarbonate lens

Output Ratings

OFF-state leakage current:
 NPN: 10 µA
 PNP: 10 µA
 ON-state saturation voltage:
 NPN: 2 V at 50 mA
 PNP: 2 V at 50 mA

Vibration and Mechanical Shock

Connections

Standard Models: 2 m (6.5 ft) or 9 m (30 ft) attached PVC cable, or 150 mm (6 in) cable with M8 or M12 threaded connection, depending on the model ordered

Environmental Rating

Standard Models: IEC IP67

Conditions

Operating Temperature: -20 °C to +55 °C (-4 °F to +131°F)
 Storage Temperature: -30 °C to +75 °C (-22 °F to +167 °F)
 95% at +50 °C maximum relative humidity (non-condensing)

Certifications



Banner Engineering BV
 Park Lane, Culliganlaan 2F bus 3
 1831 Diegem, BELGIUM



Turck Banner LTD Blenheim House
 Blenheim Court
 Wickford, Essex SS11 8YT
 GREAT BRITAIN



Required Overcurrent Protection



WARNING: Electrical connections must be made by qualified personnel in accordance with local and national electrical codes and regulations.

Overcurrent protection is required to be provided by end product application per the supplied table.

Overcurrent protection may be provided with external fusing or via Current Limiting, Class 2 Power Supply.

Supply wiring leads < 24 AWG shall not be spliced.

For additional product support, go to www.bannerengineering.com.

Supply Wiring (AWG)	Required Overcurrent Protection (A)	Supply Wiring (AWG)	Required Overcurrent Protection (A)
20	5.0	26	1.0
22	3.0	28	0.8
24	1.0	30	0.5

FCC Part 15 Class A for Unintentional Radiators

This equipment has been tested and found to comply with the limits for a Class A digital device, pursuant to Part 15 of the FCC Rules. These limits are designed to provide reasonable protection against harmful interference when the equipment is operated in a commercial environment. This equipment generates, uses, and can radiate radio frequency energy and, if not installed and used in accordance with the instruction manual, may cause harmful interference to radio communications. Operation of this equipment in a residential area is likely to cause harmful interference in which case the user will be required to correct the interference at his own expense.

(Part 15.21) Any changes or modifications not expressly approved by the party responsible for compliance could void the user's authority to operate this equipment.

Industry Canada ICES-003(A)

This device complies with CAN ICES-3 (A)/NMB-3(A). Operation is subject to the following two conditions: 1) This device may not cause harmful interference; and 2) This device must accept any interference received, including interference that may cause undesired operation.

Cet appareil est conforme à la norme NMB-3(A). Le fonctionnement est soumis aux deux conditions suivantes : (1) ce dispositif ne peut pas occasionner d'interférences, et (2) il doit tolérer toute interférence, y compris celles susceptibles de provoquer un fonctionnement non souhaité du dispositif.

Dimensions

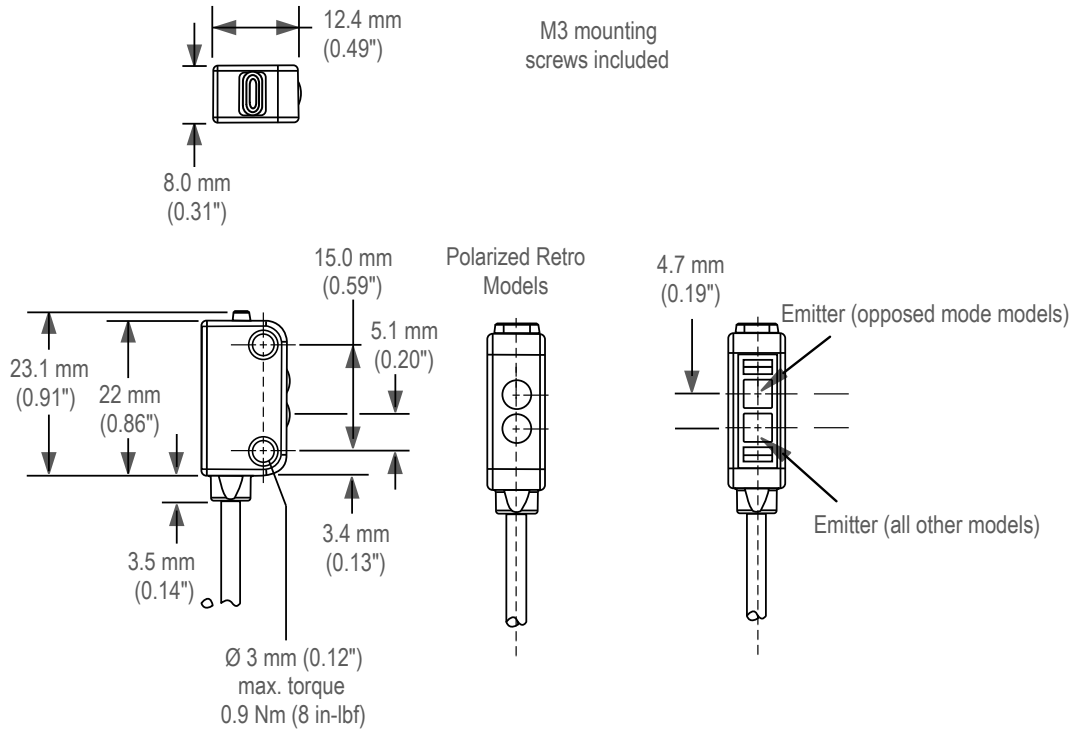

Performance Curves

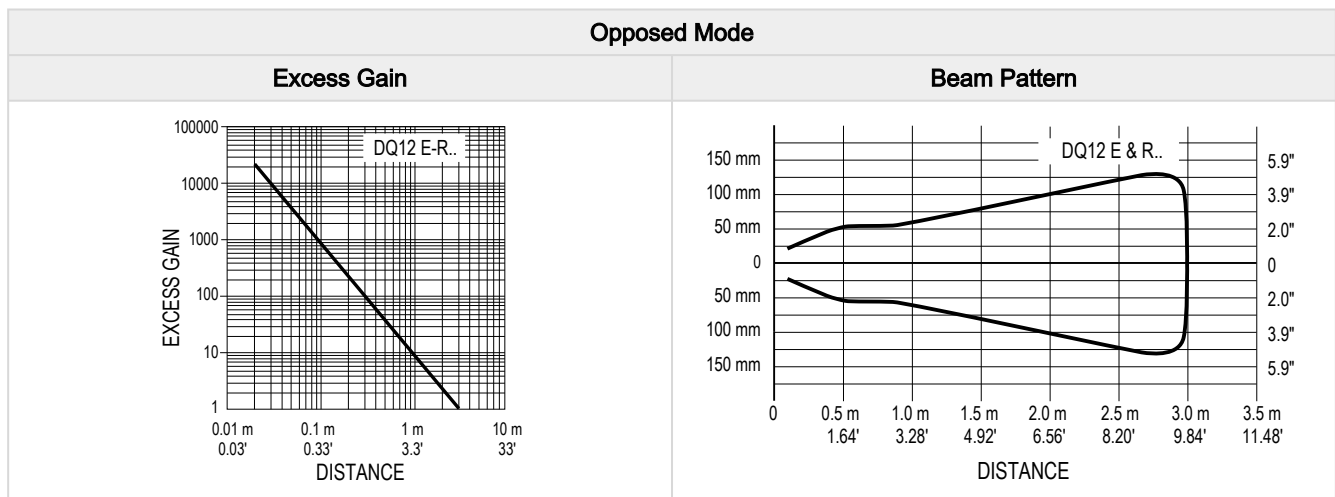

Retroreflective and polarized retroreflective performance is based on the use of a model **BRT-60X40C** retroreflector.

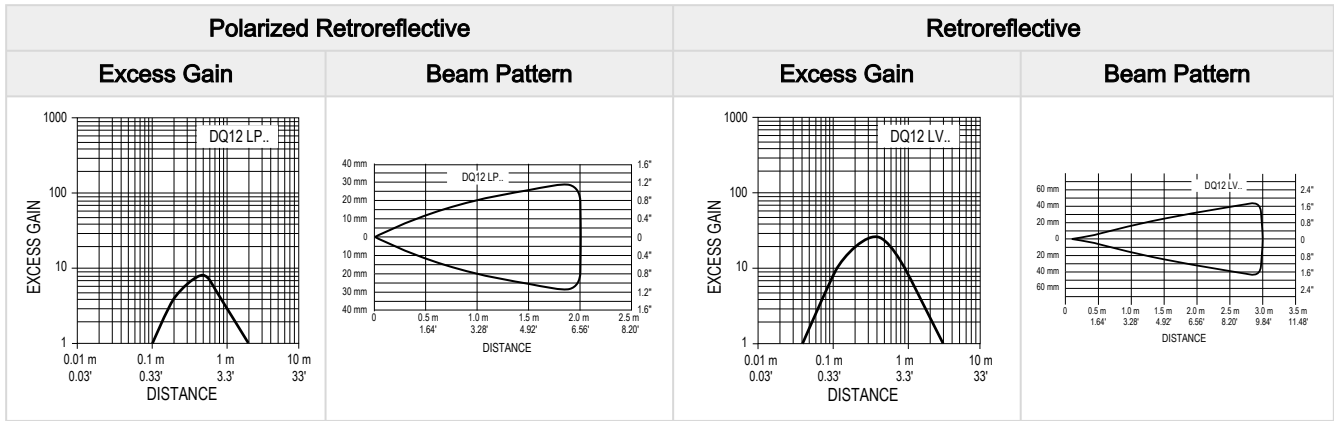

Fixed-field focus and spot sizes are typical. Performances are based on the use of a 90% reflectance white test card.*

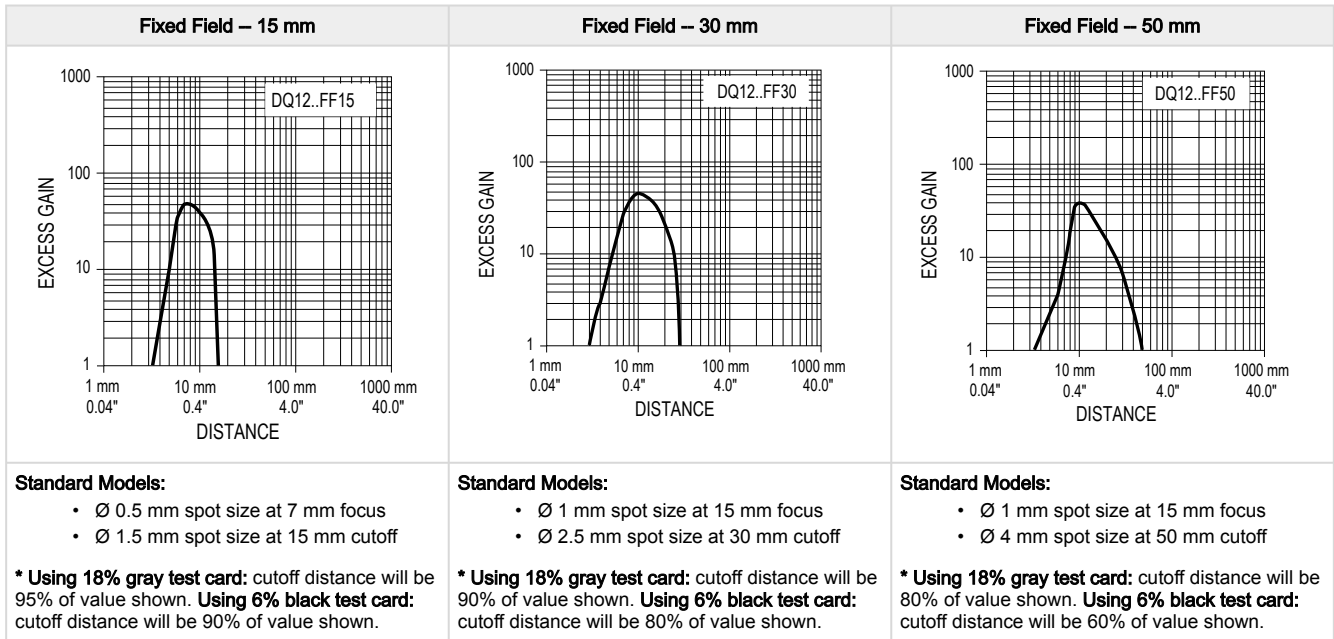

Chapter Contents

Cordsets 9
 Brackets 10
 Apertures 10

Chapter 4 Accessories

Cordsets

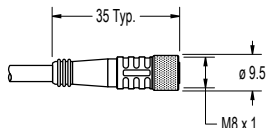
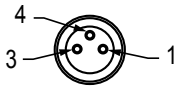
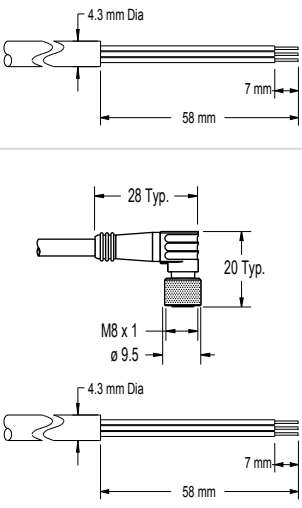
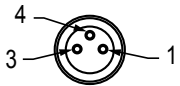
3-pin Single-Ended Threaded M8 Female Cordsets				
Model	Length	Style	Dimensions	Pinout (Female)
PKG3M-2	2 m (6.56 ft)	Straight		 <p>1 = Brown 3 = Blue 4 = Black</p>
PKG3M-4	4 m (13.12 ft)			
PKG3M-5	5 m (16.4 ft)			
PKG3M-7	7 m (22.96 ft)			
PKG3M-9	9 m (29.52 ft)			
PKG3M-10	10 m (32.81 ft)	Right-Angle		 <p>1 = Brown 3 = Blue 4 = Black</p>
PKW3M-2	2 m (6.56 ft)			
PKW3M-5	5 m (16.40 ft)			
PKW3M-9	9 m (29.53 ft)			

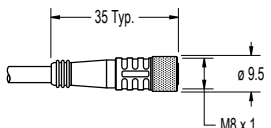
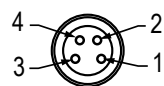
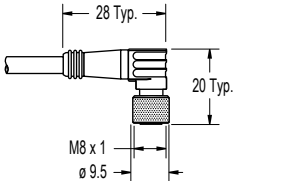
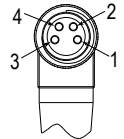
4-Pin Threaded M8 Cordsets—Single Ended				
Model	Length	Style	Dimensions	Pinout (Female)
PKG4M-2	2.04 m (6.68 ft)	Straight		
PKG4M-5	5 m (16.4 ft)			
PKG4M-9	9.04 m (29.6 ft)			
PKW4M-2	2 m (6.56 ft)	Right Angle		 <p>1 = Brown 2 = White 3 = Blue 4 = Black</p>
PKW4M-5	5 m (16.4 ft)			
PKW4M-9	9 m (29.5 ft)			

4-Pin Threaded M12 Cordsets—Single Ended				
Model	Length	Style	Dimensions	Pinout (Female)
MQDC-406	2 m (6.56 ft)	Straight		
MQDC-415	5 m (16.4 ft)			
MQDC-430	9 m (29.5 ft)			
MQDC-450	15 m (49.2 ft)			
MQDC-406RA	2 m (6.56 ft)	Right-Angle		
MQDC-415RA	5 m (16.4 ft)			
MQDC-430RA	9 m (29.5 ft)			
MQDC-450RA	15 m (49.2 ft)			

Brackets

<p>SMBQ12T</p> <ul style="list-style-type: none"> Right-angle bracket 20-ga. 300 series stainless steel <p>Hole center spacing: A to B = 7.6 Hole size: A = 3.5 x 8.1, B = ø 3.2</p>	
----------------------------------------------------------------------------------------------------------------------------------------------------------------------------------------------------------------------------------------	--

<p>SMBQ12A</p> <ul style="list-style-type: none"> Adjustable right-angle bracket 20-ga. 300 series stainless steel <p>Hole center spacing: A to B = 7.6 Hole size: A = 3.5 x 8.1, B = ø 3.2</p>	
---------------------------------------------------------------------------------------------------------------------------------------------------------------------------------------------------------------------------------------------------	--

Apertures

Opposed-mode sensors (standard models only) may be fitted with apertures to narrow or shape the sensor’s effective beam to more closely match the size or profile of the objects being sensed. A common example is using “line” (or “slot”) type apertures to sense thread.

NOTE: The use of apertures will reduce the sensing range (see table below).

Model	Description	Pieces	Reduced Sensor Range (Two Apertures Used)	
Circular				
APQ12-5	0.5 mm (0.02 in) diameter	10	60 mm (2.4 in)	
APQ12-1	1 mm (0.04 in) diameter	10	190 mm (7.5 in)	
APQ12-1.5	1.5 mm (0.06 in) diameter	10	400 mm (15.7 in)	
APQ12-2	2 mm (0.08 in) diameter	10	725 mm (28.5 in)	
Horizontal Slot				
APQ12-5H	0.5 mm (0.02 in)	10	350 mm (13.8 in)	
APQ12-1H	1 mm (0.04 in)	10	725 mm (28.5 in)	
Vertical Slot				
APQ12-5V	0.5 mm (0.02 in)	10	450 mm (17.7 in)	
APQ12-1V	1 mm (0.04 in)	10	900 mm (35.4 in)	
Protective Jacket				
APQ12-4S	4 mm (0.16 in) square	10	2000 mm (78.7 in)	
APKQ12	Kit containing two of each aperture above	18	—	

Chapter Contents

Clean with Mild Detergent and Warm Water 12
Repairs 12
Contact Us 12
Banner Engineering Corp Limited Warranty 12

Chapter 5 Product Support and Maintenance

Clean with Mild Detergent and Warm Water

Handle the sensor with care during installation and operation. Sensor windows soiled by fingerprints, dust, water, oil, etc. create stray light that may degrade the peak performance of the sensor.

Wipe down the device with a soft cloth dampened with a mild detergent and warm water solution. Do not use any other chemicals for cleaning.

Repairs

Contact Banner Engineering for troubleshooting of this device. **Do not attempt any repairs to this Banner device; it contains no field-replaceable parts or components.** If the device, device part, or device component is determined to be defective by a Banner Applications Engineer, they will advise you of Banner's RMA (Return Merchandise Authorization) procedure.

IMPORTANT: If instructed to return the device, pack it with care. Damage that occurs in return shipping is not covered by warranty.

Contact Us

Banner Engineering Corp. headquarters is located at: 9714 Tenth Avenue North | Plymouth, MN 55441, USA | Phone: + 1 888 373 6767

For worldwide locations and local representatives, visit www.bannerengineering.com.

Banner Engineering Corp Limited Warranty

Banner Engineering Corp. warrants its products to be free from defects in material and workmanship for one year following the date of shipment. Banner Engineering Corp. will repair or replace, free of charge, any product of its manufacture which, at the time it is returned to the factory, is found to have been defective during the warranty period. This warranty does not cover damage or liability for misuse, abuse, or the improper application or installation of the Banner product.

THIS LIMITED WARRANTY IS EXCLUSIVE AND IN LIEU OF ALL OTHER WARRANTIES WHETHER EXPRESS OR IMPLIED (INCLUDING, WITHOUT LIMITATION, ANY WARRANTY OF MERCHANTABILITY OR FITNESS FOR A PARTICULAR PURPOSE), AND WHETHER ARISING UNDER COURSE OF PERFORMANCE, COURSE OF DEALING OR TRADE USAGE.

This Warranty is exclusive and limited to repair or, at the discretion of Banner Engineering Corp., replacement. **IN NO EVENT SHALL BANNER ENGINEERING CORP. BE LIABLE TO BUYER OR ANY OTHER PERSON OR ENTITY FOR ANY EXTRA COSTS, EXPENSES, LOSSES, LOSS OF PROFITS, OR ANY INCIDENTAL, CONSEQUENTIAL OR SPECIAL DAMAGES RESULTING FROM ANY PRODUCT DEFECT OR FROM THE USE OR INABILITY TO USE THE PRODUCT, WHETHER ARISING IN CONTRACT OR WARRANTY, STATUTE, TORT, STRICT LIABILITY, NEGLIGENCE, OR OTHERWISE.**

Banner Engineering Corp. reserves the right to change, modify or improve the design of the product without assuming any obligations or liabilities relating to any product previously manufactured by Banner Engineering Corp. Any misuse, abuse, or improper application or installation of this product or use of the product for personal protection applications when the product is identified as not intended for such purposes will void the product warranty. Any modifications to this product without prior express approval by Banner Engineering Corp will void the product warranties. All specifications published in this document are subject to change; Banner reserves the right to modify product specifications or update documentation at any time. Specifications and product information in English supersede that which is provided in any other language. For the most recent version of any documentation, refer to: www.bannerengineering.com.

For patent information, see www.bannerengineering.com/patents.

 [LinkedIn](#)

 [X \(formerly Twitter\)](#)

 [Facebook](#)

