

# MULTI-BEAM Sensors Family



Original Instructions  
p/n: 32887 Rev. A  
August 28, 2023

© Banner Engineering Corp. All rights reserved.

# Contents

---

<b>Contents</b> .....	<b>2</b>
<b>Chapter 1 MULTI-BEAM® Overview</b>	
Select the MULTI-BEAM Components .....	3
Dimensions .....	4
Documents for the MULTI-BEAM Series .....	5
<b>Chapter 2 3- and 4-Wire Sensors</b>	
Scanner Block Models .....	7
Opposed Mode Scanner Block Models .....	7
Retroreflective Scanner Block Models .....	8
Diffuse Scanner Block Models .....	10
Convergent Scanner Block Models .....	12
Fiber Optic Scanner Block Models .....	13
Ambient Light Scanner Block .....	17
MULTI-BEAM 3- and 4-Wire Scanner Block Modifications .....	18
Power Block Models .....	19
Power Block (DC) Models .....	19
Power Block (AC) Models .....	24
Logic Modules .....	31
Logic Modules (3- and 4-Wire) Models .....	31
Logic Module Modifications .....	33
<b>Chapter 3 2-Wire Sensors</b>	
Scanner Blocks .....	35
Scanner Block (2-Wire) Models .....	35
Scanner Block (2-Wire) Performance Curves .....	37
Scanner Block (2-Wire) Wiring .....	40
Power Block (2-wire) Models .....	41
Power Block (2-Wire) Wiring Diagrams .....	41
Power Block (2-Wire) General Wiring .....	43
Logic Modules (2-Wire) .....	45
Logic Module (2-Wire) Models .....	45
<b>Chapter 4 Product Support</b>	
Accessories and Replacement Parts for the MULTI-BEAM Family .....	47
Banner Engineering Corp Limited Warranty .....	49
Contact Us .....	49

Chapter Contents

Select the MULTI-BEAM Components ..... 3  
 Dimensions ..... 4  
 Documents for the MULTI-BEAM Series ..... 5

# Chapter 1 MULTI-BEAM® Overview

A Banner MULTI-BEAM® Sensor is a compact modular self-contained photoelectric switch consisting of three components: a scanner block, a power block, and a logic module.

The **scanner** block comprises the housing for the sensor and contains a complete modulated photoelectric amplifier, the emitter and receiver opto-elements and lenses, and space for the other modules.

The **power** block module provides the interface between the scanner block and the external circuit. It contains a power supply for the MULTI-BEAM plus a switching device (except in emitter-only power blocks) to interface the sensor to the circuit to be controlled.

The **logic** module interconnects the power block and scanner block both electrically and mechanically. It provides the desired timing logic function (if any) plus the ability to program the output for either light- or dark-operate.

The emitters of MULTI-BEAM opposed mode emitter/receiver pairs do not require a logic module. Emitter scanner blocks are supplied with a blade-pin to interconnect the scanner block and power block. Power block and logic modules are purchased separately. This modular design, with field-replaceable power block and logic modules, permits a large variety of sensor configurations, resulting in exactly the right sensor for any photoelectric application.

There are two families of MULTI-BEAM sensors: 3- and 4-wire, and 2-wire.

- Three- and four-wire MULTI-BEAMs offer the greatest selection of sensor configurations. They permit either AC or DC operation and offer the fastest response times and the greatest sensing ranges.
- Two-wire MULTI-BEAMs are used in AC-powered applications where simplicity and convenience of wiring are important. They are physically and electrically interchangeable with heavy-duty limit switches.

The circuitry of all MULTI-BEAM components is encapsulated within rugged, corrosion-resistant PBT housings, which meet or exceed NEMA 1, 3, 12, and 13 ratings.

Most MULTI-BEAM scanner blocks include Banner's patented Alignment Indicating Device (AID™), which lights a top-mounted LED when the sensor sees its own modulated light source and pulses the LED at a rate proportional to the received light signal. Most MULTI-BEAM sensor assemblies are UL listed and certified by CSA (see power block listings). All MULTI-BEAM components (except power block models 2PBR and 2PBR2) are solid-state for unlimited life.

## Select the MULTI-BEAM Components

MULTI-BEAM sensors are made up of three components: scanner block, power block, and logic module. This is true for all MULTI-BEAMs with the exception of opposed mode emitter units which require only a power block (no logic module).

**WARNING:**



- **Do not use this device for personnel protection**
- Using this device for personnel protection could result in serious injury or death.
- This device does not include the self-checking redundant circuitry necessary to allow its use in personnel safety applications. A device failure or malfunction can cause either an energized (on) or de-energized (off) output condition.

If you have any questions about selecting MULTI-BEAM components, please contact your Banner sales engineer or Banner's applications department.

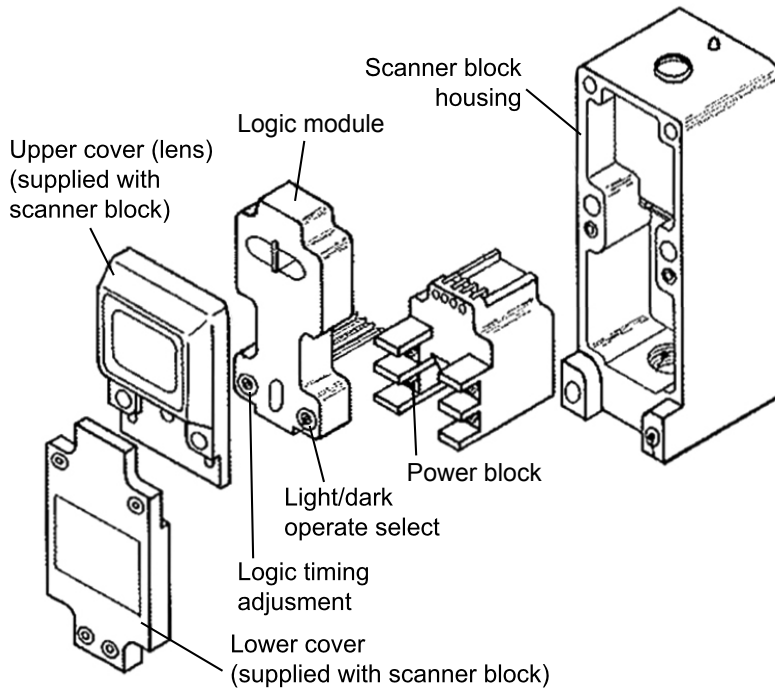

1. Determine which family of MULTI-BEAM sensors is appropriate for your application: 3- and 4-wire or 2-wire.
2. Decide which scanner block (within the selected family) is best for the application. The guidelines in the catalog introduction will help you to determine the best sensing mode. Then narrow the choice by comparing the specifications listed in the following charts and on the pages referenced in the charts.
3. Choose a power block and logic module to complete the MULTI-BEAM assembly.  
Components snap together without interwiring to form a complete photoelectric sensing system that meets your exact requirements while maintaining the simplicity of a self-contained sensor.

Other MULTI-BEAM products include the Edgeguide System (datasheet p/n 03506) and the Optical Data Transmitter (datasheet p/n 03321).

## Dimensions

All measurements are listed in millimeters [inches], unless noted otherwise.

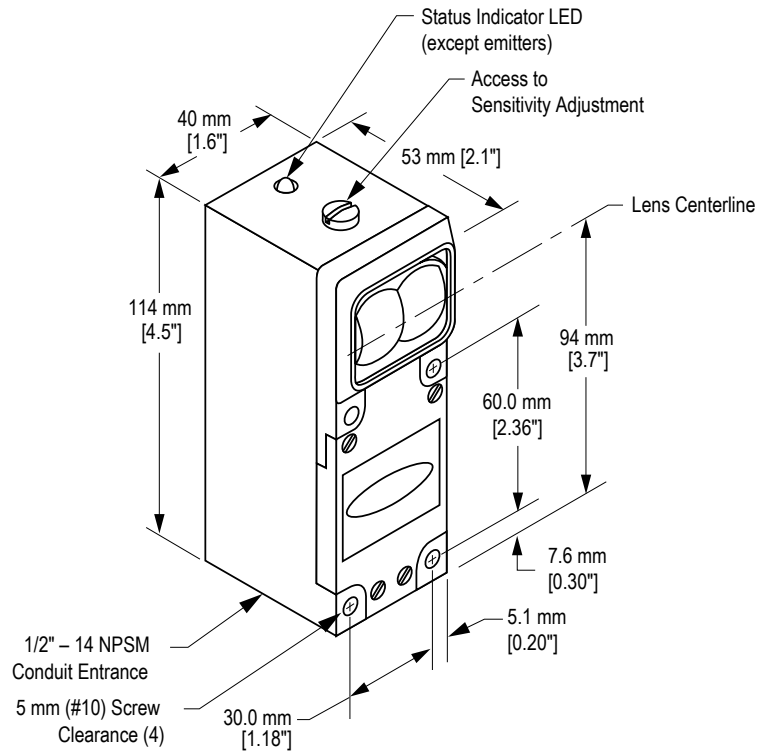

## Documents for the MULTI-BEAM Series

### Scanner Blocks

- MULTI-BEAM Series 3-Wire and 4-Wire Scanner Blocks (Opposed), p/n [03492](#)
- MULTI-BEAM Series 3-Wire and 4-Wire Scanner Blocks (Diffuse), p/n [03495](#)
- MULTI-BEAM Series 3-Wire and 4-Wire Scanner Blocks (Convergent), p/n [03494](#)
- MULTI-BEAM Series 3-Wire and 4-Wire Scanner Blocks (Retroreflective), p/n [03493](#)
- MULTI-BEAM Series 3-Wire and 4-Wire Scanner Blocks (Glass Fiber Optic), p/n [03496](#)
- MULTI-BEAM Series 2-Wire Scanner Blocks, p/n [03498](#)
- MULTI-BEAM Series Ambient Light Scanner Blocks, p/n [03497](#)

### Power Blocks

- MULTI-BEAM Series 3-Wire and 4-Wire AC Power Blocks, p/n [03501](#)
- MULTI-BEAM Series 3-Wire and 4-Wire DC Power Blocks, p/n [03499](#)
- MULTI-BEAM Series 2-Wire AC Power Blocks, p/n [03508](#)

### Logic Modules

- MULTI-BEAM Series 3-Wire and 4-Wire Logic Modules, p/n [03304](#)
- MULTI-BEAM Series 2-Wire Logic Modules, p/n [03507](#)

### Other

- MULTI-BEAM Series Optical Edgeguide System, p/n [03506](#)
- MULTI-BEAM Series Optical Data Transmitter System, p/n [03321](#)

*Blank page*

Chapter Contents

Scanner Block Models..... 7  
 Power Block Models..... 19  
 Logic Modules ..... 31

## Chapter 2 3- and 4-Wire Sensors

Three- and four-wire MULTI-BEAMS offer the greatest selection of sensor configurations. They permit either AC or DC operation and offer the fastest response times and the greatest sensing ranges.

### Scanner Block Models

#### Opposed Mode Scanner Block Models

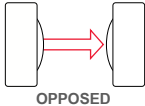

Opposed mode MULTI-BEAMS consist of an emitter and receiver, which are sold separately. They provide the highest excess gain and the longest sensing range of all sensing models, and are recommended for use whenever possible.

Sensing takes place when an object breaks the light beam. Both infrared and visible red types are available. All models have Banner's exclusive AID™ alignment system.

**SBE/SBR1.** This opposed pair has the highest gain available at 1-millisecond response.

Models	Range	Performance	Beam
<b>SBE</b> Emitter	45 m (150 ft)	Response Time: 1 ms Repeatability: 0.03 ms	Infrared, 940 nm (Beam diameter of 1 inch)
<b>SBR1</b> Receiver			

**SBED/SBRD1.** With a fast response and small effective beam, this pair will detect objects as small as 1/4-inch in cross-section and moving at up to 10 feet per second. This is the best choice for repeatability of position sensing.

Models	Range	Performance	Beam
<b>SBED</b> Emitter	3 m (10 ft)	Response Time: 1 ms Repeatability: 0.03 ms	Infrared, 880 nm (Beam diameter of 0.12 inch)
<b>SBRD1</b> Receiver			

**SBEX/SBRX1.** This pair is the best choice for opposed sensing in extremely dirty environments. Use these models for outdoor applications and all applications requiring an opposed range of 100 feet or more. You may also use these models side-by-side for long-distance mechanical convergence sensing. Alignment is difficult beyond 400 feet.

Models	Range	Performance	Beam
<b>SBEX</b> Emitter	200 m (700 ft)	Response Time: 10 ms Repeatability: 0.7 ms	Infrared, 940 nm (Beam diameter of 1 inch)
<b>SBRX1</b> Receiver			

**SBEV/SBRX1.** SBEV has a visible red beam for easiest alignment and system monitoring.

Models	Range	Performance	Beam
<b>SBEV</b> Emitter	30 m (100 ft)	Response Time: 10 ms Repeatability: 0.1 ms	Visible Red, 650 nm (Beam diameter of 1 inch)
<b>SBRX1</b> Receiver			

**SBEXD/SBRXD1.** A wide beam angle and high gain for the most forgiving emitter-receiver alignment.

Models	Range	Performance	Beam
SBEXD Emitter SBRXD1 Receiver	9 m (30 ft)	Response Time: 10 ms Repeatability: 0.7 ms	Infrared, 880 nm (Beam diameter of 0.12 inch)

Scanner Block Performance Curves (Opposed Mode)

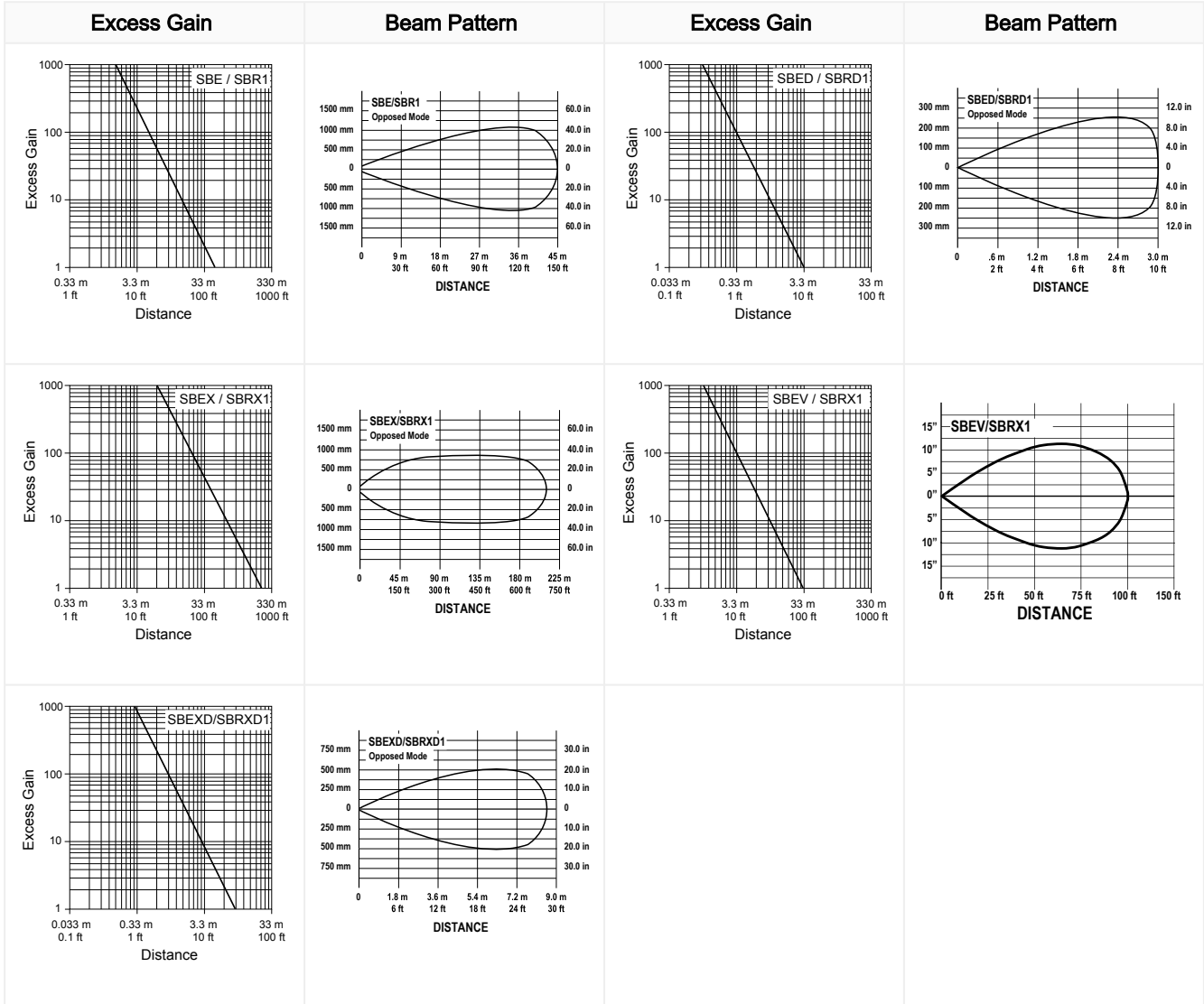

Retroreflective Scanner Block Models

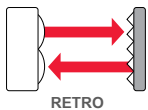

Retroreflective mode MULTI-BEAMS combine the emitter and receiver into one unit. A retroreflective target is used to return the emitted light to the receiver along the same optical axis.

Sensing occurs when an object passes between the sensor and the reflector, interrupting the beam. A variety of retroreflective materials are available, see ["Accessories and Replacement Parts for the MULTI-BEAM Family"](#) on page 47.

Models	Performance	Beam	Application Notes
SBLV1	<b>Range:</b> 0.15 m to 9 m (6 in to 30 ft) <b>Response Time:</b> 1 ms on/off <b>Repeatability:</b> 0.3 ms	Visible Red, 650 nm	A visible red beam makes alignment very easy. SBLV1 is the first choice for most retroreflective applications. Not for use in dirty environments. Instead, use opposed mode, or models SBL1 and SBLX1. Do not locate retroreflector closer than 152 mm (6 in) from sensor.
SBLVAG1	<b>Range:</b> 0.3 m to 4.5 m (12 in to 15 ft) <b>Response Time:</b> 1 ms on/off <b>Repeatability:</b> 0.3 ms	Visible Red, 650 nm	Uses anti-glare filter for immunity to direct reflections from shiny objects. Use only with models BRT-3 or BRT-1.5 retroreflective targets. Use only in clean environments. Do not locate retroreflector closer than 305 mm (12 in) from sensor.
SBL1	<b>Range:</b> 0.025 m to 9 m (1 in to 30 ft) <b>Response Time:</b> 1 ms on/off <b>Repeatability:</b> 0.3 ms	Infrared, 940 nm	Use where invisible beam is advantageous (for example, security applications or film processing). First choice for retroreflective sensing in slightly or moderately dirty environments. Do not use when object to break the beam has a shiny surface, unless the angle of light to the surface can be predicted.
SBLX1	<b>Range:</b> 3 m to 22 m (10 ft to 75 ft) with one BRT-3; 3 m to 30 m (10 ft to 100 ft) with three BRT-3 targets <b>Response Time:</b> 10 ms on/off <b>Repeatability:</b> 1.5 ms	Infrared, 880 nm	Highest gain available in a retroreflective sensor. Use for all applications requiring more than 9 m (30 ft) range where opposed mode sensors cannot be used. Objects must pass at a distance of at least 3 m (10 ft) from the sensor to be reliably sensed.

Scanner Block Performance Curves (Retroreflective)

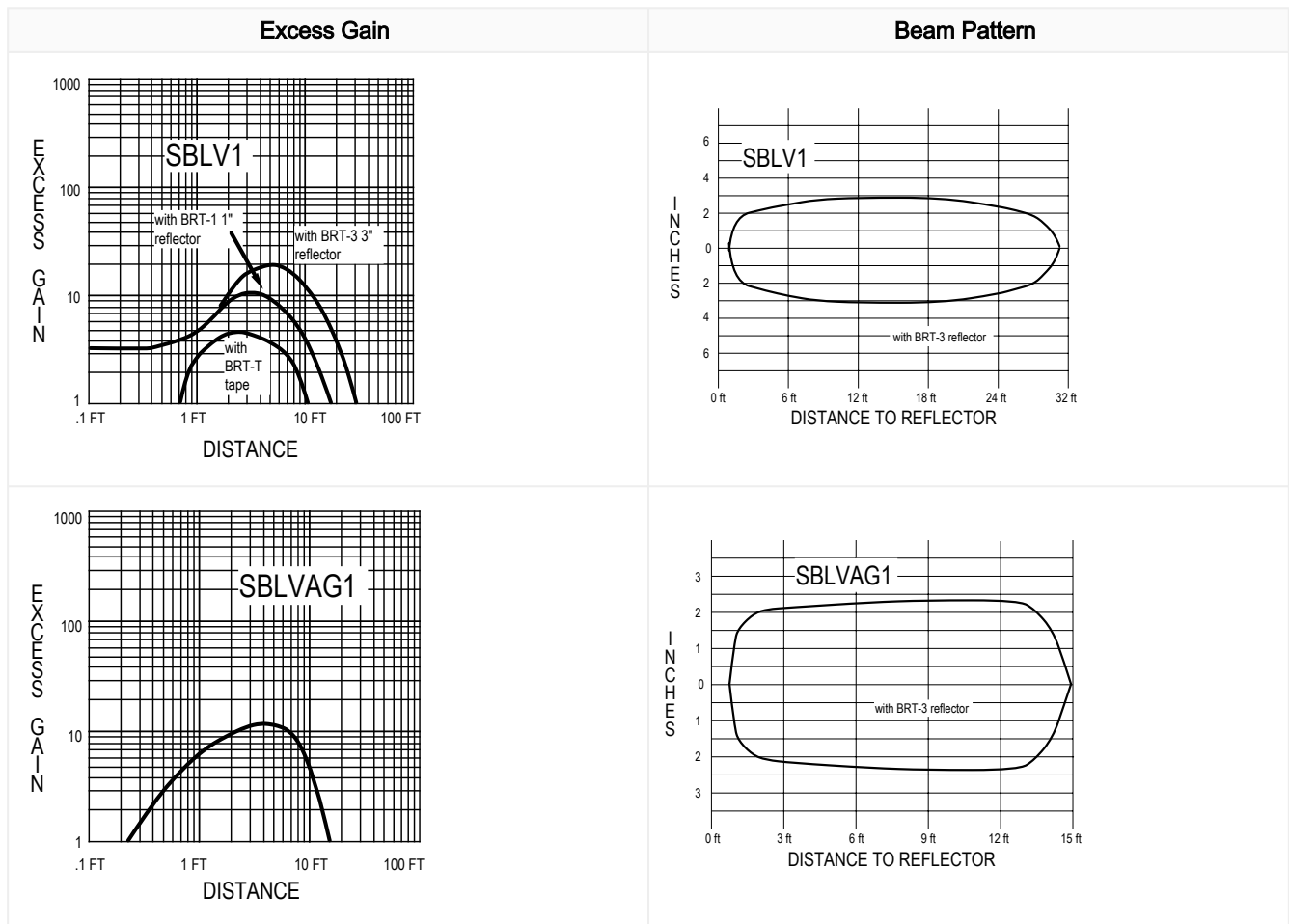

Continued on page 10

Continued from page 9

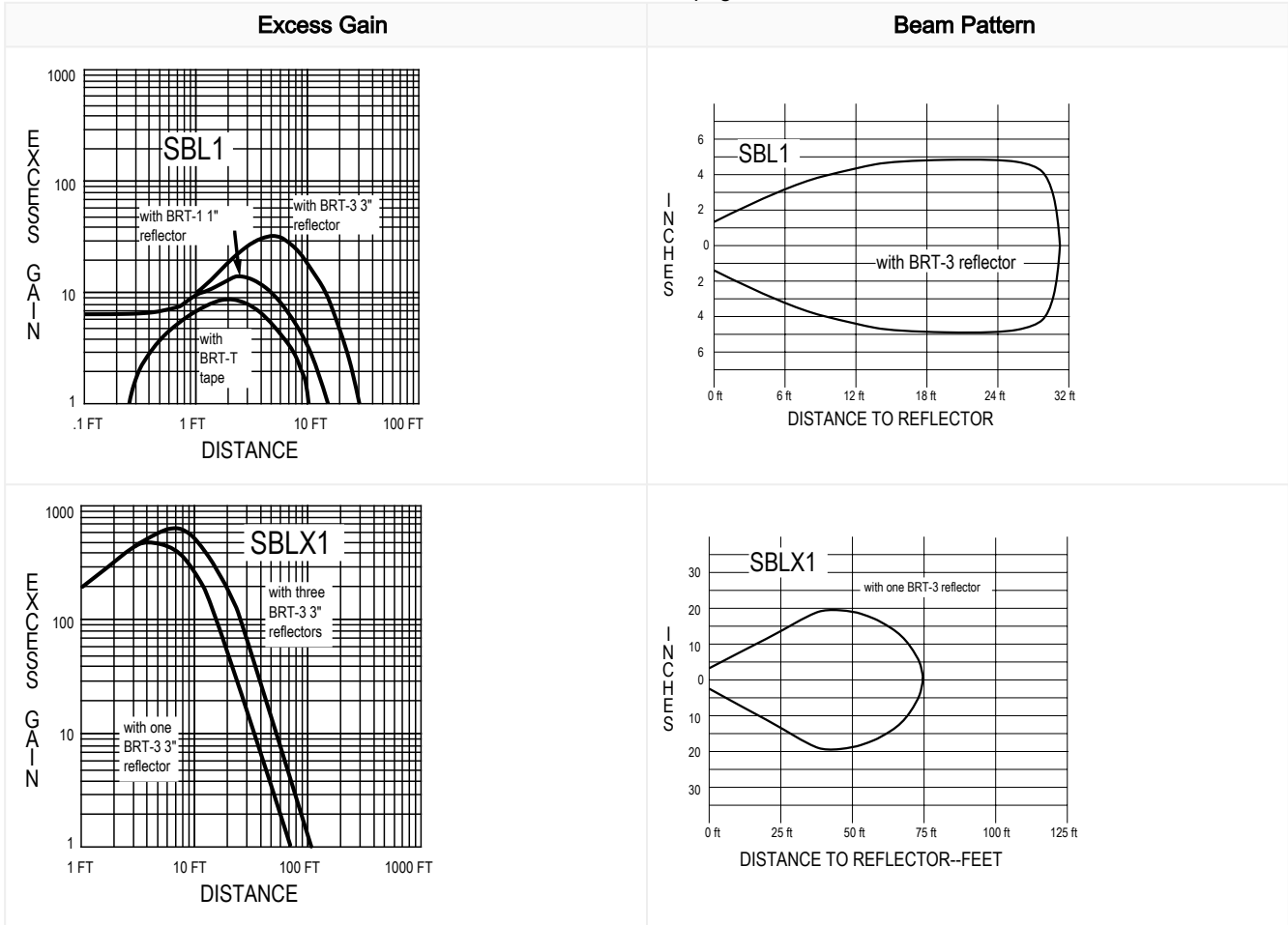

### Diffuse Scanner Block Models

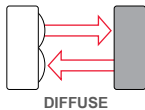

As a general rule regarding background objects in diffuse sensing, verify that the distance to the nearest background object is at least three times the distance from the sensor to the object to be sensed.

For example, if a product passes one inch from an SBD1 sensor, the nearest background object should be at least three inches further away.

Models	Specifications	Application	Description
SBD1	<p><b>Range:</b> 30 cm (12 in)</p> <p><b>Response:</b> 1 ms on/off</p> <p><b>Repeatability:</b> 0.3 ms</p> <p><b>Beam:</b> infrared, 940 nm</p>	Short Range, Fast Response	The SBD1 model is a short-range diffuse mode sensor with a relatively wide field of view. It loses gain rapidly near the end of its range. As a result, its response to background objects is suppressed. Use caution when applying any diffuse mode sensor if background reflectivity exceeds the reflectivity of the object to be sensed.
SBDL1	<p><b>Range:</b> 60 cm (24 in)</p> <p><b>Response:</b> 1 ms on/off</p> <p><b>Repeatability:</b> 0.3 ms</p> <p><b>Beam:</b> infrared, 940 nm</p>	Intermediate Range, Fast Response	The SBDL1 model has a longer range than SBD1, but with less response to objects passing the sensor at close range, and greater sensitivity to background objects. Models SBD1 and SBDL1 are identical except for their upper cover (lens) assembly (SBD1 uses UC-D; SBDL1 uses UC-L).

Continued on page 11

Continued from page 10

Models	Specifications	Application	Description
SBDX1	<p><b>Range:</b> 2 m (6 ft)</p> <p><b>Response:</b> 10 ms on/off</p> <p><b>Repeatability:</b> 1.5 ms</p> <p><b>Beam:</b> infrared, 880 nm</p>	Long Range, for Low-Reflectivity Objects	The SBDX1 model is used for diffuse (proximity) mode applications when there is no requirement for less than 10 ms response and where there are no background objects to falsely return light. The SBX1 has a high excess gain for reliable detection of most materials with low reflectivity which pass within 10 in (25 cm) of the sensor.
SBDX1MD	<p><b>Range:</b> 60 cm (24 in)</p> <p><b>Response:</b> 10 ms on/off</p> <p><b>Repeatability:</b> 1.5 ms</p> <p><b>Beam:</b> infrared, 880 nm</p>	Wide Beam Angle for Clear Objects	The SBDX1MD model has a wide beam angle for forgiving alignment to shiny objects and provides detection of clear or translucent glass or plastics. It has high excess gain at close range, with fast fall-off of gain near the maximum sensing distance for optical suppression of reflective background. This model may be created from model SBDX1 by substituting upper cover (lens) model UC-DMB.

### Scanner Block Performance Curves (Diffuse)

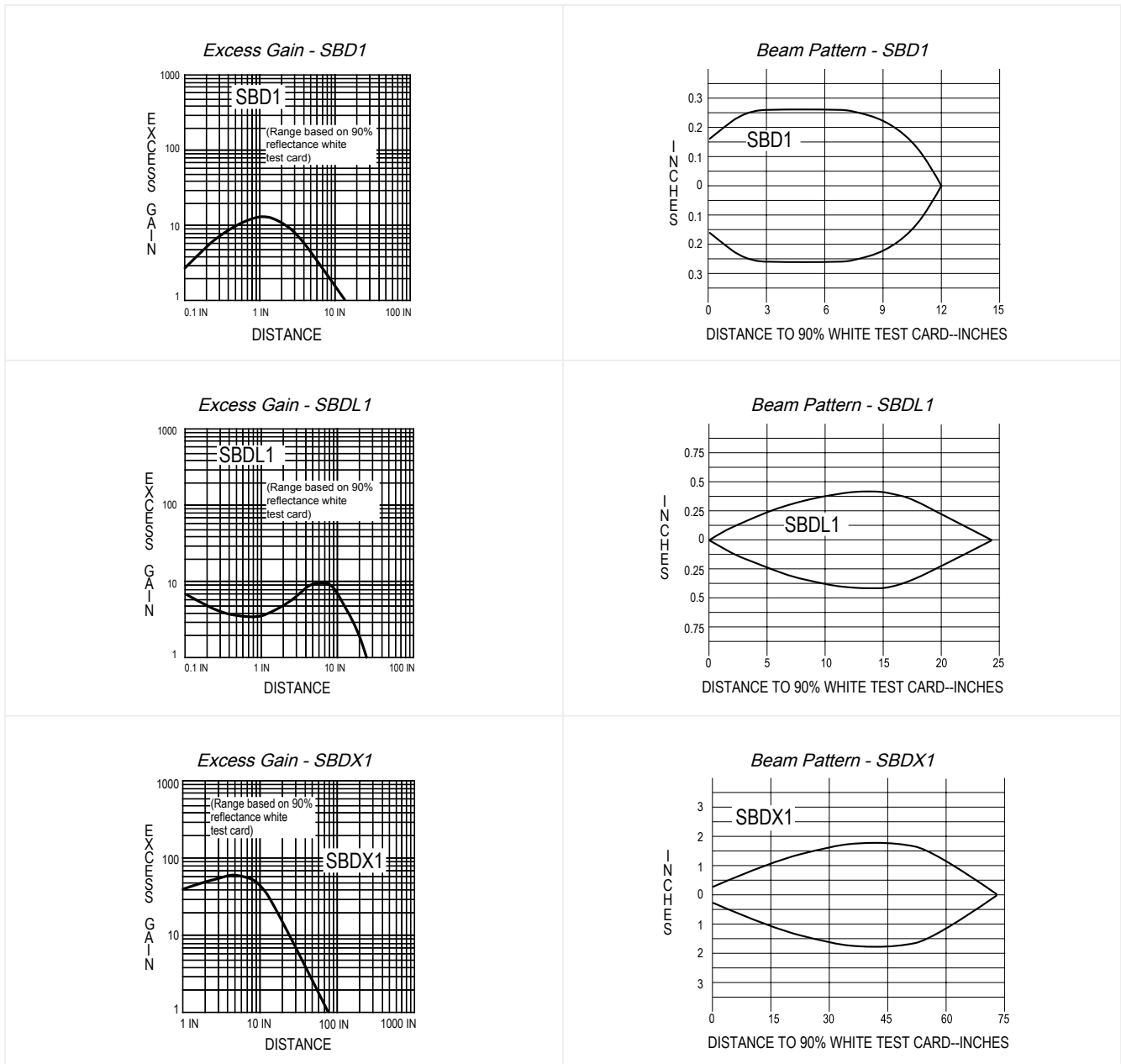

Continued on page 12

Continued from page 11

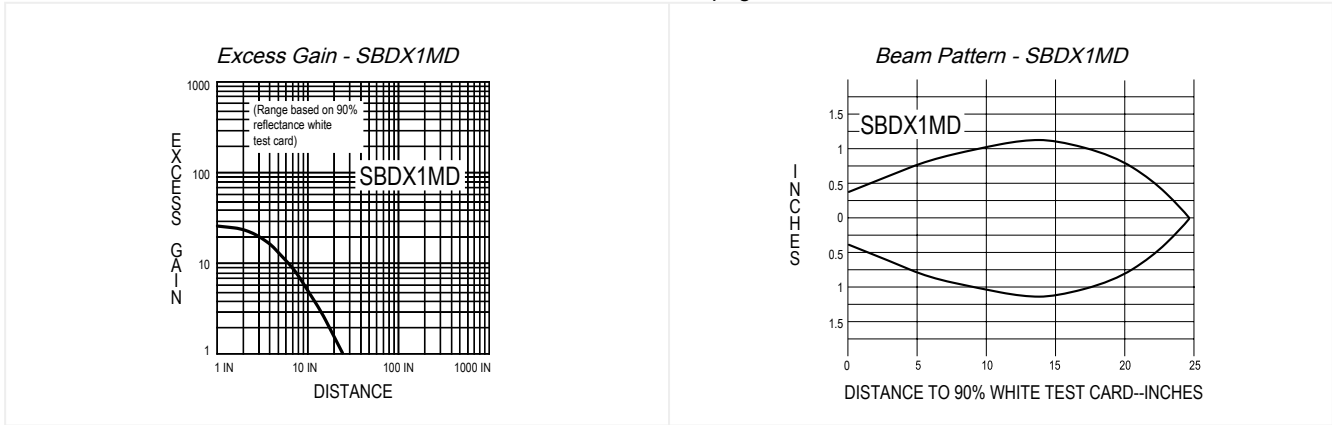

### Convergent Scanner Block Models

Convergent mode MULTI-BEAM sensors combine the emitter and receiver into one unit. Optics produce a sensing "spot" at a fixed distance (focus point) in front of the lens.

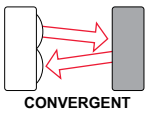

CONVERGENT

Convergent mode sensing is an ideal choice for position control of transparent products and for detecting products that are only a fraction of an inch away from another reflective surface. Convergent sensing is also a good second choice (after opposed mode sensing) for precise position control of opaque materials. All models have Banner's exclusive AID™ alignment system.

Models	Focus	Beam	Application Notes
SBCV1	<b>Focus:</b> 38 mm (1.5 in) <b>Repeatability:</b> 0.3 ms <b>Response Time:</b> 1 ms	650 nm visible red	1.5 mm (0.06 in) dia, visible red spot, for precise positioning, edge-guiding, and small parts detection. Some products larger than 1 inch tall may be sensed against an immediate background, like parts on a conveyor. Excellent for high-contrast, registration-sensing applications (except red on white). Use with LM6-1 logic module for speed detection sensing of gear teeth, pulley hubs, or chain links.
SBCVG1		560 nm visible green	3 mm (0.12 in) dia, visible green spot. Use to detect color differences (for example, color registration marks), including red-on-white combinations.
SBC1	<b>Focus:</b> 38 mm (1.5 in) <b>Repeatability:</b> 0.3 ms <b>Response Time:</b> 1 ms		Infrared LED light source provides higher gain for reliable sensing of products of low reflectivity, while controlling sensing depth of field. Does not offer the same precision possible with visible light models. Good for sensing clear materials within the sensor's depth of field, and for reliably counting the flow of radiused products that are kept at a fixed distance from the sensor (for example, bottles against a conveyor guide rail).
SBC1-4	<b>Focus:</b> 100 mm (4 in) <b>Repeatability:</b> 0.3 ms <b>Response Time:</b> 1 ms	940 nm infrared	
SBC1-6	<b>Focus:</b> 150 mm (6 in) <b>Repeatability:</b> 0.3 ms <b>Response Time:</b> 1 ms		
SBCX1	<b>Focus:</b> 38 mm (1.5 in) <b>Repeatability:</b> 1.5 ms <b>Response Time:</b> 10 ms	880 nm infrared	These models offer the greatest optical gain available in any reflective mode sensor. They can reliably detect most non-reflective black materials in applications where opposed mode sensing is not possible (for example, inked web break monitoring). The high power of these models gives them a wide depth of field and a large sensing spot. As a result, they cannot easily ignore objects in the background or foreground, and cannot be used for precise position control (use model SBCV1).
SBCX1-4	<b>Focus:</b> 100 mm (4 in) <b>Repeatability:</b> 1.5 ms <b>Response Time:</b> 10 ms		

Continued on page 13

Continued from page 12

Models	Focus	Beam	Application Notes
SBCX1-6	<p><b>Focus:</b> 150 mm (6 in)</p> <p><b>Repeatability:</b> 1.5 ms</p> <p><b>Response Time:</b> 10 ms</p>		

### Scanner Block Performance Curves (Convergent)

Distances are measured using a 90% white test card.

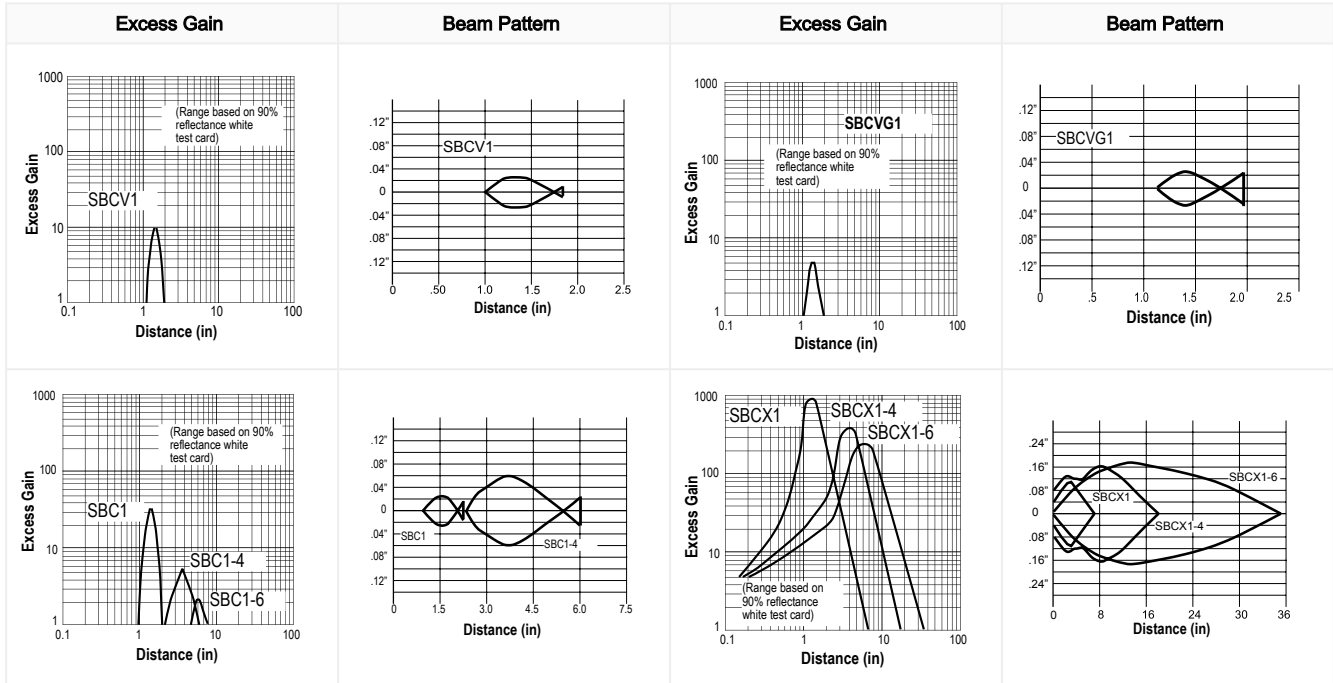

### Fiber Optic Scanner Block Models

**SBEF and SBRF1:** Use with individual glass fiber optic assemblies in lieu of model SBF1 where it is inconvenient to run fibers from a single scanner block.

**SBEXF and SBRXF1:** Use in place of model SBFX1 for long-range opposed fiber optic sensing. Or use where high excess gain is required and it is difficult to run the fibers to both sides of the process from a single scanner block.

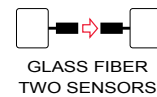

Models	Performance	Beam
SBEF Emitter	Response Time: 1 ms	Opposed Mode Pairs, Infrared, 880 nm
SBRF1 Receiver	Repeatability: 0.03 ms	
SBEXF Emitter	Response Time: 10 ms	
SBRXF1 Receiver	Repeatability: 0.7 ms	

**SBFX1** is the first choice for glass fiber optic applications, except in fiber optic retroreflective applications or where faster response speed or visible light area a requirement. Model SBFX1 contains both emitter and receiver and thus accepts either one bifurcated fiber optic assembly or two individual fiber optic cables.

The excess gain of model SBFX1 is the high available in the photoelectric industry. As a result, opposed individual fibers operate reliably in many very hostile environments. Also, special miniature bifurcated fiber optic assemblies with bundle sizes as small as 0.020 inches (0.5 mm) in diameter may be used successfully with model SBFX1 for diffuse mode sensing. The excess gain curves and beam patterns illustrate response with standard 0.060 inch (1.5 mm) diameter and 0.12 inch (3 mm) diameter bundles.

Response for smaller or larger bundle sizes may be interpolated.

Note: Opposed range shown are meant to illustrate excess gain only and are limited by fiber length. Use scanner block models SBEXF and SBRXF1 for long-range opposed fiber optic sensing.

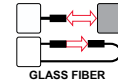

Models	Performance	Beam
<b>SBFX1</b>	Response Time: 10 ms Repeatability: 1.5 ms	Opposed or Diffuse Mode, Infrared, 880 nm

**SBFV1 Visible Red Light Source** supplies visible red light to the emitter half of a glass fiber optic photoelectric system. Visible light sensors have less optical energy compared to infrared systems. There are, however, some sensing situations that require visible light wavelengths to realize adequate optical contrast.

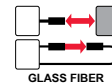

Opposed fibers using visible red light are used to reliably sense translucent materials (plastic bottles) that appear transparent to infrared opposed sensors. Fiber assembly model BT13S used with a model L9 or L16F lens makes an excellent visible light sensing system for retroreflective code reading as well as for many short-range retroreflective applications, such as retro sensing across a narrow conveyor.

When combined with a bifurcated fiber, model SBFV1 may be used for color registration sensing for applications where there is a large difference between the two colors, for example, black on white. For combinations of red on white, however, the visible green light source of model SBFVG1 is needed. Visible light emitters are also helpful for visual system alignment and maintenance.

Models	Performance	Beam
<b>SBFV1</b>	Response Time: 1 ms Repeatability: 0.3 ms	Opposed, Retroreflective, or Diffuse Mode, Visible Red, 650 nm

**SBFVG1 Visible Green Light Source for Color Sensing (Registration Control).** Convergent beam sensors like model SBCVG1 are often used for color registration sensing. However, there are some registration applications where the use of bifurcated fiber optics is beneficial. Fiber optics are able to fit into tight locations that are too small for a convergent sensor.

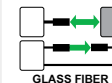

Fibers also allow a choice of image size. It is important to create an image size that is smaller than the registration mark to maximize optical contrast and to ease sensor response requirements. Fibers allow a match of the light image to the geometry of the registration mark. Scanner block model **SBFVG1** will sense most bold color differences, including red on white. Use only power blocks that switch dc (for example, PBT, PBP, PBO, and PBAT) for fast response.

Models	Performance	Beam
<b>SBFVG1</b>	Response Time: 1 ms Repeatability: 0.3 ms	Diffuse Mode, Visible Green, 560 nm

**SBF1 High-Speed Scanner Block.** Fiber optics are often used to sense small parts. Small parts or narrow profiles that move at a high rate of speed can require sensors with fast response times for reliable detection. High-speed fiber optics sensors are ideal for sensing gear or sprocket teeth or other targets in applications involving counters or shift registers for position control.

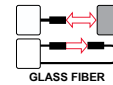

Selection of the fiber optic sensing tip should involve matching the effective beam of the fiber to the profile of the part to be sensed to maximize the time that the part is sensed and/or the time between adjacent parts. Combining the best selection of fiber tip geometry with a high speed sensor will result in a highly repeatable position sensing system.

The model BT13S fiber optic assembly used with a model L9 or L16F lens and a high speed scanner block is an excellent system for retroreflective code reading or for almost any short range retroreflective sensing application. Response time of a MULTI-BEAM sensor is also a function of the power block. For this reason, use only power blocks that switch DC (PBT, PBP, PBO, PBAT, etc) to take advantage of the scanner block's fast response time.

Models	Performance	Beam
<b>SBF1</b>	Response Time: 1 ms Repeatability: 0.3 ms	Opposed, Retroreflective, or Diffuse Mode, Infrared, 940 nm

**SBF1MHS Very High-Speed Scanner Block** is the model SBF1 modified for high-speed (300  $\mu$ s) response. It may be used in either fiber optic opposed or fiber optic diffuse mode. Note that the faster response comes at the expense of lower gain (see excess gain curves for both models and MHS modification note).

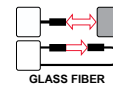

Models	Performance	Beam
<b>SBF1MHS</b>	Response Time: 300 $\mu$ s Repeatability: 100 $\mu$ s	Opposed or Diffuse Mode, Infrared, 940 nm

### Scanner Block Performance Curves (Fiber Optic)

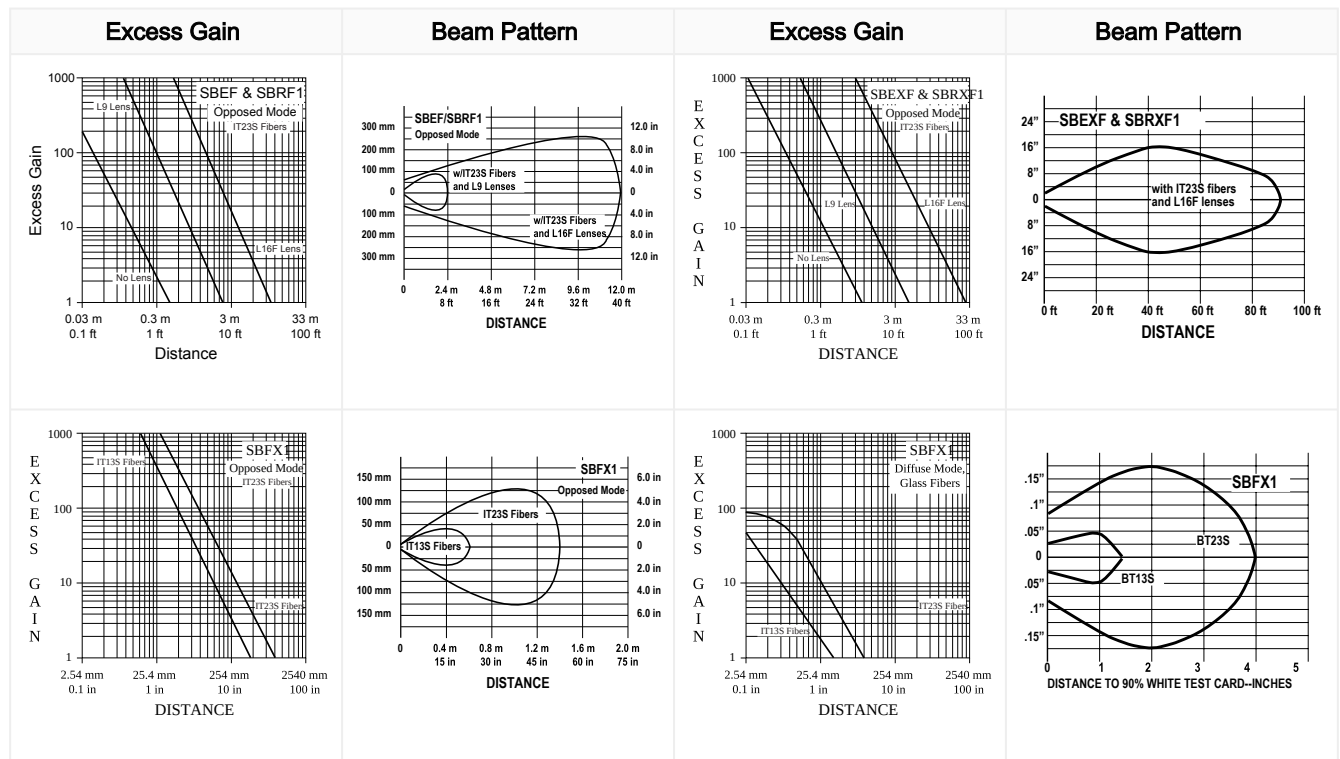

Continued on page 16

Continued from page 15

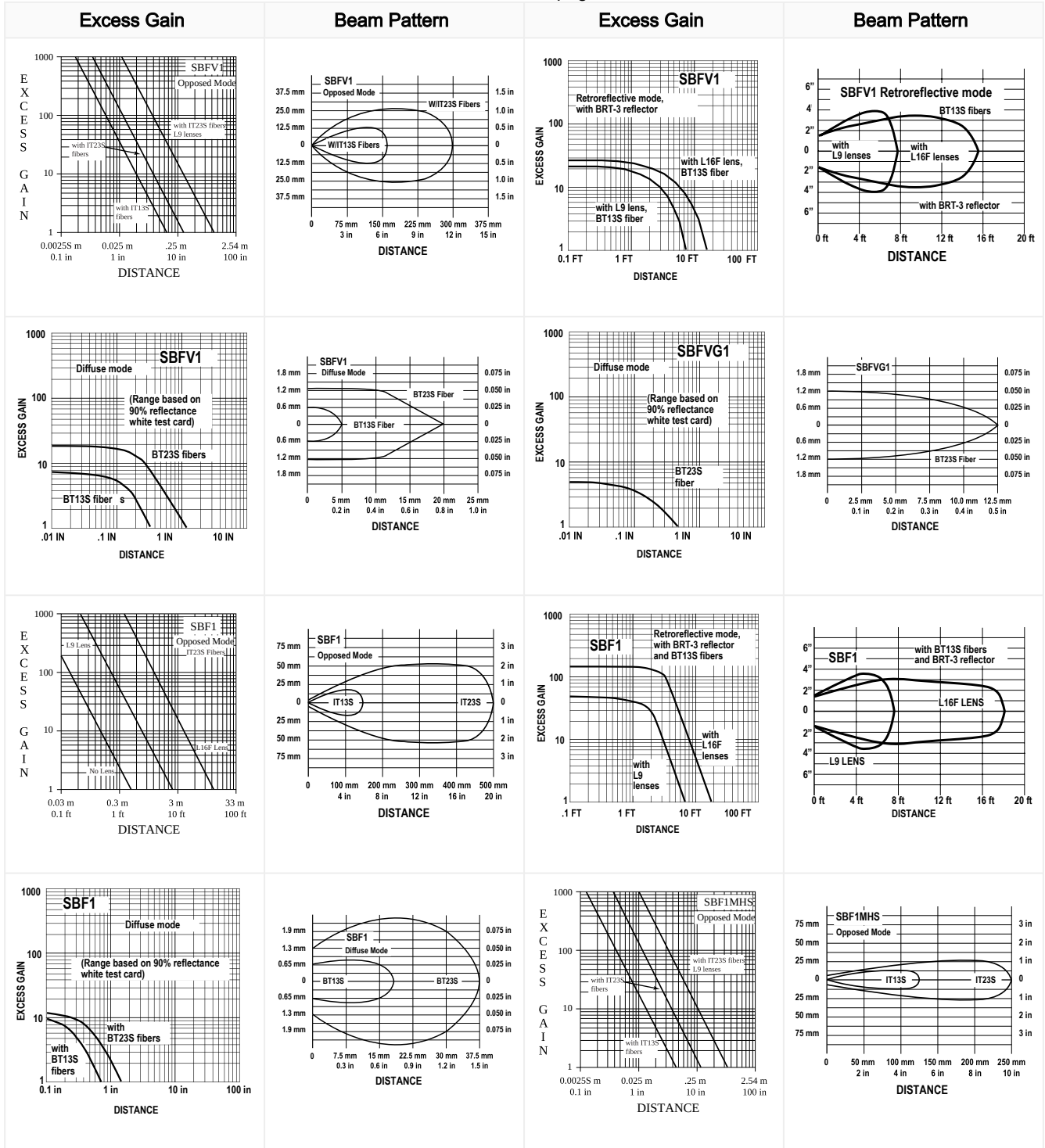

Continued on page 17

Continued from page 16

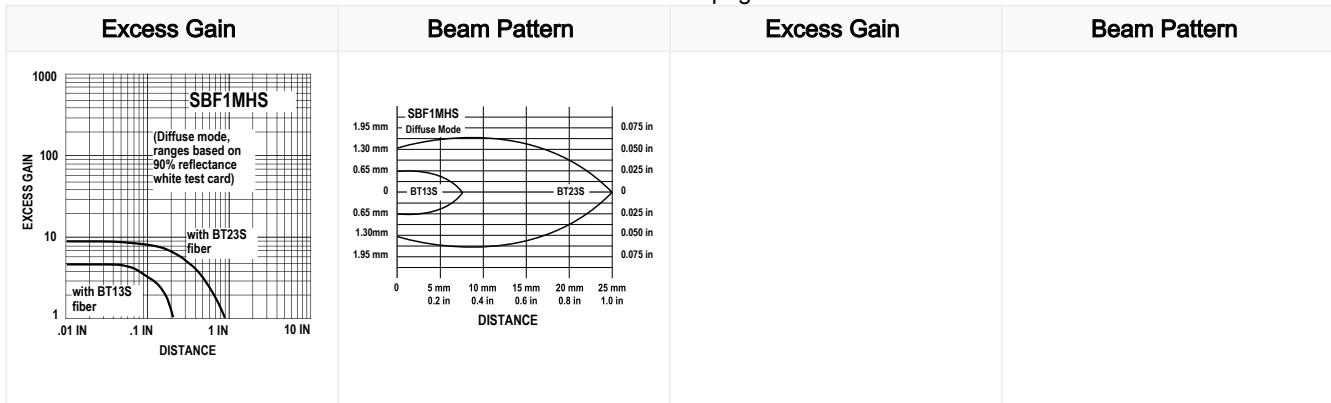

## Ambient Light Scanner Block

A Banner MULTI-BEAM Ambient Light Receiver is a compact modular self-contained photoelectric switch that is operated by sunlight or an incandescent, fluorescent, infrared, or laser light source.

A common application involves mounting the scanner block underneath a roller conveyor, with the sensor pointing upwards between the rollers at the overhead factory lighting. Any objects passing over the sensor would then cast a shadow, resulting in an output (dark operate). Ambient receivers are used with LM5-14 delay logic to sense daylight for outdoor lighting control. These sensors can also sense the large amounts of infrared light (heat energy) which is emitted by hot or molten glass, metal, or plastic during processing of these materials.

**NOTE:** Ambient light receiver scanner blocks also work with 2-wire AC power blocks and logic modules. However, the light/dark operate functions are reversed when using 2-wire operation.

The circuitry of all MULTI-BEAM components is encapsulated within rugged, corrosion-resistant PBT polyester housings that meet or exceed NEMA 1, NEMA 3, NEMA 12, and NEMA 13 ratings. MULTI-BEAM ambient light receiver scanner blocks have a top-mounted red indicator LED that lights whenever a light level sufficient to cause a change in the output is being sensed. All MULTI-BEAM scanner blocks are totally solid-state for unlimited life.

## Ambient Light Receiver Scanner Block Models

Model Number	Amplifier	Response	Optical Response	Diagram
<b>SBAR1</b>	Normal Gain	10 ms on/off	Ultraviolet through near infrared (includes all visible wavelengths)	
<b>SBAR1GH</b>	High Gain			

Model SBAR1 is for general applications, while model SBAR1GH is a high-gain version and is about twenty times more sensitive to light as compared to the SBAR1. The range at which either model senses a light source depends on both the intensity of the light source and the contrast in intensity between the source and the rest of the ambient light in the viewing area.

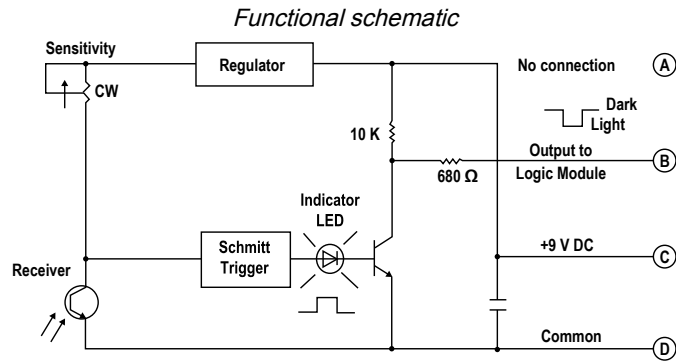

### Ambient Light Receiver Scanner Block (Glass Fiber Optic) Model

Model Number	Amplifier	Response	Optical Response	Diagram
<b>SBAR1GHF</b>	High Gain	10 ms on/off	Wavelengths from visible blue through near infrared	

Model SBAR1GHF is identical to model SBAR1GH except that it is equipped with an upper cover assembly (model UC-RF) which allows an individual glass fiber optic assembly to be attached to the receiver optoelement. This model is used for ambient light detection in locations which are either too confined or too hot for the mounting of a complete scanner block. A typical application involves sensing product presence or counting during processing of red-hot or molten glass or metal. The addition of an L9, L16F, L16FAL, or L16FSS lens to a threaded fiber assembly (for example, IT23S) can narrow the angle of light acceptance to less than the angle of the SBAR1 lens. The high gain amplifier of model SBAR1GHF helps to offset light losses which are experienced with fiberoptic light pipes.

**NOTE:** Glass fibers do not efficiently pass ultraviolet wavelengths.

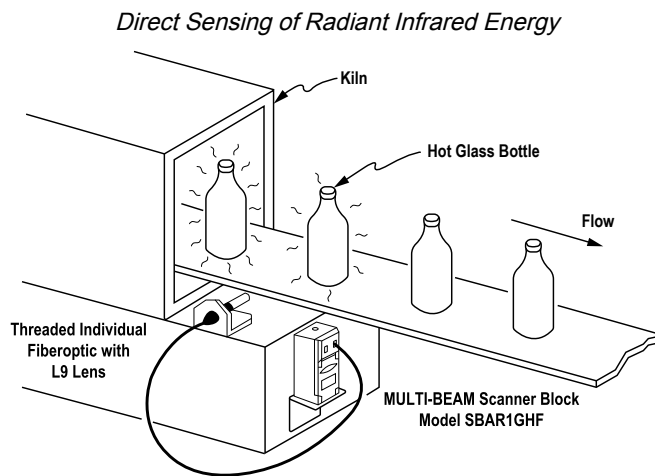

### MULTI-BEAM 3- and 4-Wire Scanner Block Modifications

The following are common modifications to MULTI-BEAM 3- and 4-wire scanner blocks. They are not stocked but are available via special order.







**Zero Hysteresis Modification "MZ".** Amplifier hysteresis may be removed from 3- and 4-wire scanner blocks when attempting to sense very small signal changes (contrasts less than 3). This modification is designated by adding the suffix

"MZ" (modified zero hysteresis). Verify all variables affecting the sensor's optical response remain constant before ordering the zero hysteresis modification.

**High-Speed Modification "MHS"**. Scanner blocks with a 1-millisecond response may be modified for a 300-microsecond (0.3 ms) response. This modification is designated by adding the suffix "MHS" to the scanner block model number (for example, SBF1MHS). The MHS modification reduces the available excess gain by about 50% and also decreases the sensor's immunity to some forms of electrical noise.

## Power Block Models

### Power Block (DC) Models

Models	Input	Output	Specifications	Certifications
PBT	10 V DC to 30 V DC at less than 60 mA (current draw depends on scanner block used). 10% max. ripple.	One open-collector NPN transistor. Current flows from the transistor to the negative side of the power supply. 250 mA max.		 
PBT48 (inactive)	44 V DC to 52 V DC at less than 60 mA (current draw depends on scanner block used). 10% max. ripple.			
PBT2	10 V DC to 30 V DC at less than 60 mA (current draw depends on scanner block used). 10% max. ripple.	Two open-collector NPN transistors: one normally open, one normally closed. 250 mA max. for each output.	On-state voltage drop of less than 1 V DC. Off-state leakage current less than 10 microamps.	
PBP	10 V DC to 30 V DC at less than 60 mA (current draw depends on scanner block used). 10% max. ripple.	One open-collector PNP transistor. Current flows from the positive side of the power supply to the transistor. 250 mA max.		 
PBP48 (inactive)	44 V DC to 52 V DC at less than 60 mA (current draw depends on scanner block used). 10% max. ripple.			
PBT-1	10 V DC to 30 V DC at less than 60 mA (current draw depends on scanner block used). 10% max. ripple.	N/A	N/A	
PBT48-1 (inactive)	44 V DC to 52 V DC at less than 60 mA (current draw depends on scanner block used). 10% max. ripple.	N/A	N/A	

### PBT and PBT48 Wiring

PBT is the most commonly used DC power block. Its output is an NPN transistor, which sends current to the negative side of the power supply. The load is connected between the output and the positive side of the power supply. The switching capacity is 250 mA. There is no connection to terminal #4.

PBT48 has exactly the same configuration as the PBT, but for 48 V DC systems.

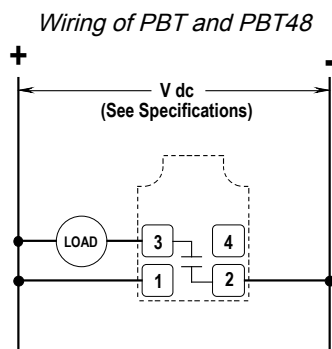

### PBT2 Wiring

PBT2 provides two NPN outputs: one normally open, and one normally closed (equivalent to SPDT relay). The normally closed output may be used when a load must de-energize when the MULTI-BEAM operates (for example, normally closed one-shot).

**NOTE:** Both outputs are open when DC power is removed.

*Wiring of PBT2*

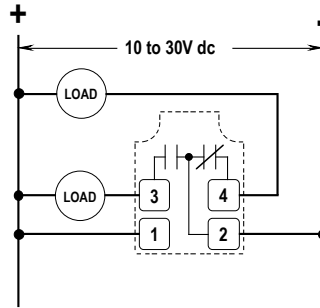

### PBP and PBP48 Wiring

PBP is similar to model PBT, except that it provides a PNP type output transistor. PNP outputs are frequently required when interfacing to logic systems and programmable logic controllers (PLCs) which require a positive source of DC voltage to generate an input condition. This type of interface may also be accomplished by using PBT with a pull-up resistor installed between transistors #1 and #3.

PBP48 has exactly the same configuration as the PBP, but for 48 V DC systems.

*Wiring of PBP and PBP48*

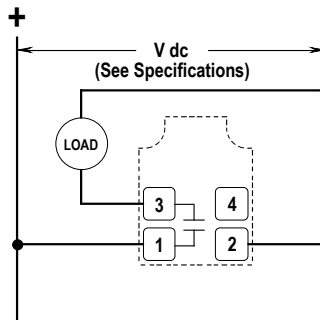

### PBT-1 and PBT48-1 Wiring

These are power blocks for emitter scanner blocks only (models SBE, SBED, SBEX, SBEV, SBEXD, SBEF, SBEXF). Emitter assemblies do not require logic modules.

*Wiring of PBT-1 and PBT48-1*

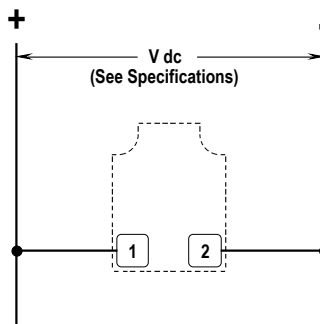

## Power Block (DC) General Wiring

Wiring to a Programmable Controller (requiring an NPN current)

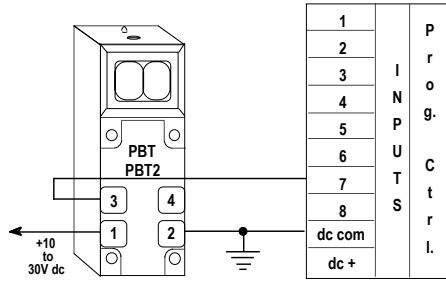

Use power blocks with NPN outputs to interface to PLCs and other logic devices requiring a current sink at the inputs. Connect the output of the power block (terminal #3) to any input of the PLC. Also, connect the negative of the MULTI-BEAM power supply (terminal #2) to the negative of the PLC power supply.

Wiring to a Programmable Controller (requiring a PNP current)

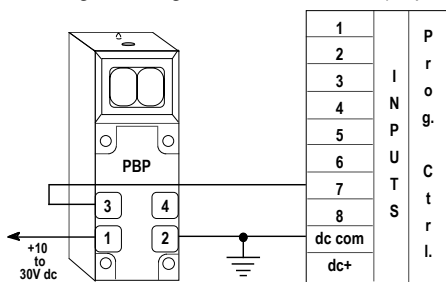

Use power blocks with PNP outputs to interface to PLCs and other logic devices requiring a current source at the inputs. Connect the output of the power block (terminal #3) to any input of the PLC. Also, connect the negative of the MULTI-BEAM power supply (terminal #2) to the negative of the PLC power supply.

Wiring to DC Relay or Solenoid (using NPN output)

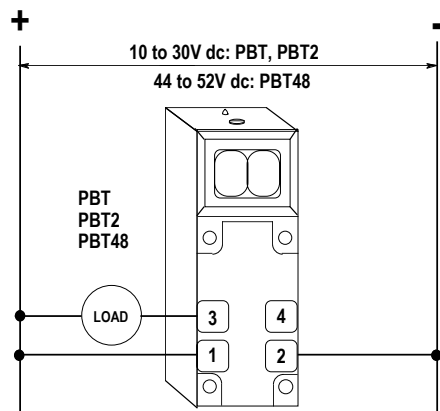

When using power blocks with current NPN outputs, simple loads connect between the power block output (terminal #3) and the positive supply (terminal #1).

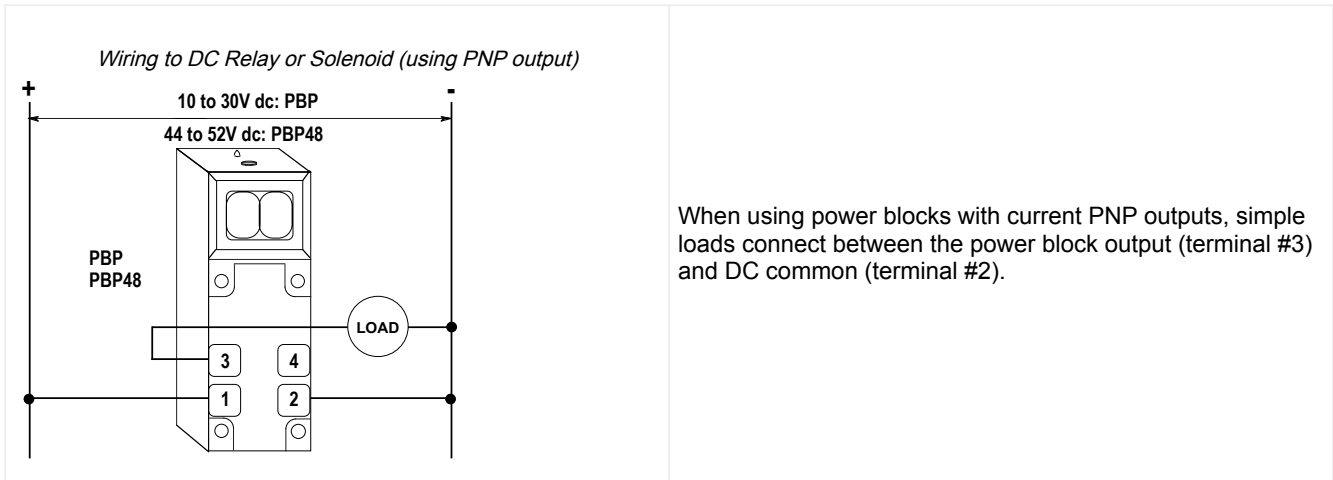

Any number of MULTI-BEAMS may be connected in parallel to one load to create LIGHT-OR (light operate mode) or DARK-OR (dark operate mode) multiple sensor logic. In most situations, MULTI-BEAM DC power blocks cannot wire in series. However, addition of an interposing relay with a normally closed contact or a Banner logic module will permit AND logic with a parallel sensor array.

**NOTE:** MULTI-BEAM DC power blocks cannot be wired in series.

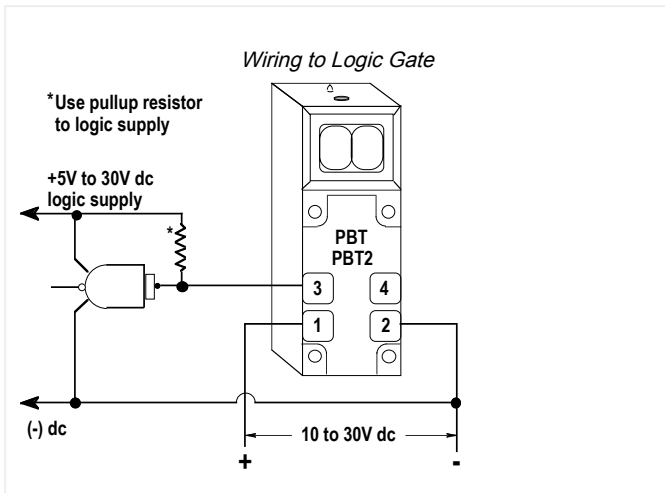
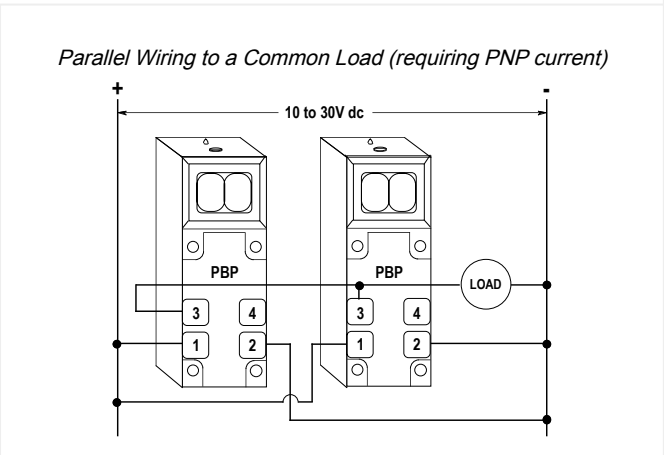
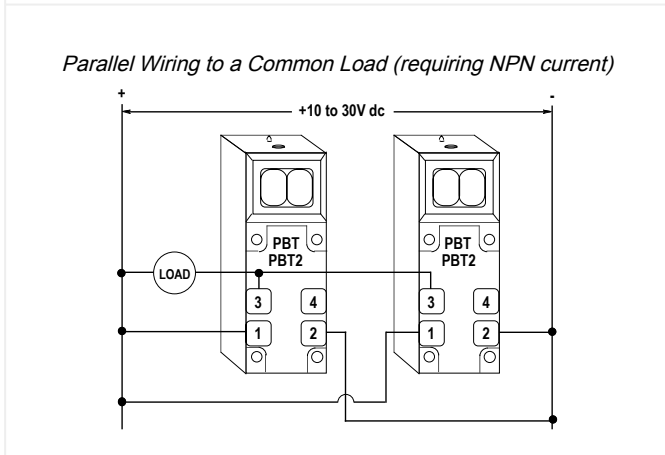

A logic zero (0 V DC) is applied to the gate input when the MULTI-BEAM output is energized. When de-energized, a logic one is applied. The logic supply must be common to the MULTI-BEAM supply negative.

*Wiring of DC Emitter*

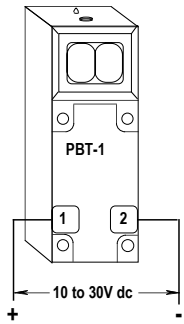

MULTI-BEAM emitter-only scanner blocks use DC power block models PBT-1 or PBT48-1. These power blocks connect directly across the DC supply, as shown. Emitter models: SBE, SBED, SBEX, SBEV, SBEXD, SBEF.

*Wiring to MAXI-AMP Logic Module*

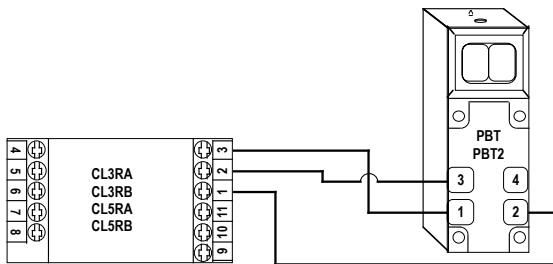

The NPN output(s) of MULTI-BEAM power block models PBT and PBT2 may be connected directly to the input of CL-series MAXI-AMP modules. A MAXI-AMP which is powered by AC voltage offers a DC supply with enough capacity to power one MULTI-BEAM sensor, as shown in this wiring diagram. When emitter/receiver pairs are used, the emitter should be powered from a separate power source (for example, using PBA-1, etc.).

*Wiring to B-Series Logic (MRB chassis)*

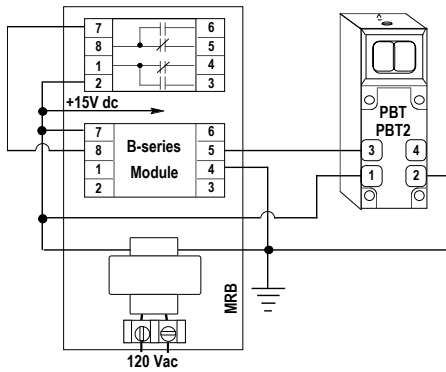

The NPN output(s) of MULTI-BEAM power block models PBT and PBT2 may be connected directly to the input (terminal #5) or to the auxiliary input (terminal #3) of any Banner B-series logic model. The MULTI-BEAM is powered by the MRB chassis as shown. Additional logic may be added on a longer chassis. Banner PLUG-LOGIC modules may also be used.

*Wiring to MICRO-AMP Logic (model MPS-15 chassis)*

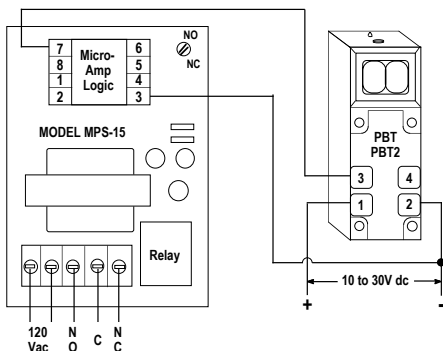

The NPN output(s) of MULTI-BEAM power block models PBT and PBT2 may be connected directly to the primary input (terminal #7) or the other inputs of MICRO-AMP logic modules. The following logic modules may be used:

- MA4-2 (one shot)
- MA5 (on/off delay)
- MA4G (4-input AND)
- MA4L (latch)

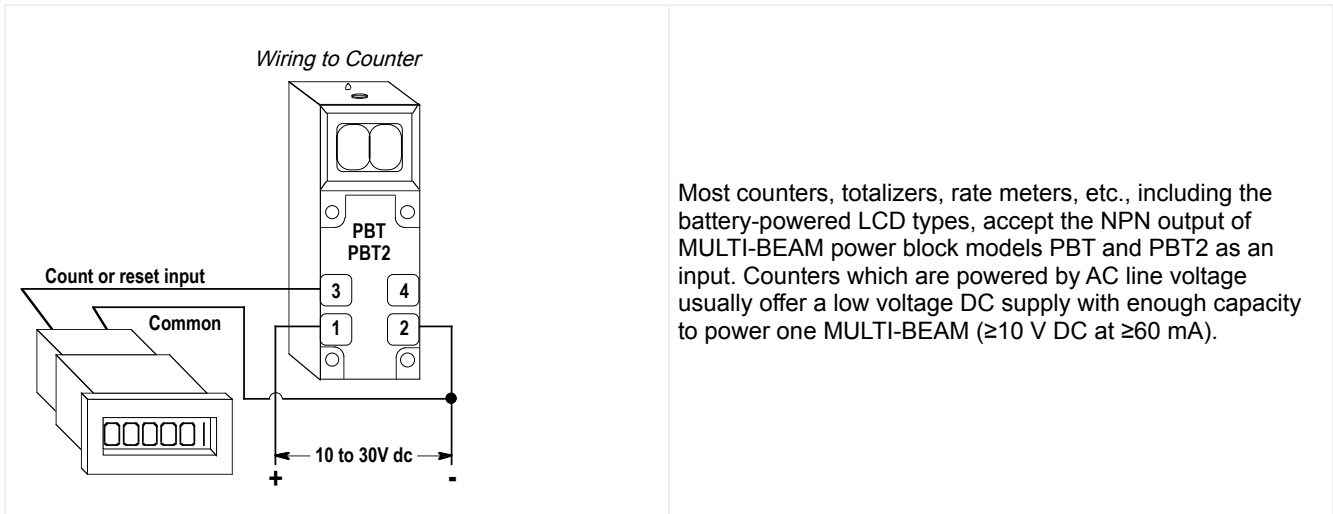





### Power Block (AC) Models

Models	Input	Certifications	Output	Specifications
PBA	105–130 V AC, 50/60 Hz	CE	SPST solid-state switch for AC, ¼ A maximum (derated to ½ at 70 °C). 10 A maximum inrush for one second or 30 A for one AC cycle (non-repeating).	On-state voltage drop of less than 2.5 V AC at full load.  Off-state leakage current less than 100 µA.  Response Time: Add 8.3 ms to the off-time response of the scanner block
PBB	210–250 V AC, 50/60 Hz			
PBD (inactive)	22–28 V AC, 50/60 Hz	UL LISTED IND. CONT. EQ. 447Y SP®		
PBD-2	11–13 V AC, 50/60 Hz	N/A		
PBAT	105–130 V AC, 50/60 Hz	CE UL LISTED IND. CONT. EQ. 447Y SP®	SPST isolated solid-state switch; 100 mA maximum (no inrush capacity), 200 V DC maximum, 140 V AC maximum.	On-state voltage drop of less than 3 V at full load. Off-state leakage current less than 100 µA.
PBBT (inactive)	210–250 V AC, 50/60 Hz		SPST isolated solid-state switch; 100 mA maximum (no inrush capacity), 350 V DC maximum, 250 V AC maximum.	
PBA-1	105–130 V AC, 50/60 Hz	CE SP®	N/A	N/A
PBB-1	210–250 V AC, 50/60 Hz			
PBD-1 (inactive)	22–28 V AC, 50/60 Hz			
PBO (inactive)	105–130 V AC, 50/60 Hz	CE UL LISTED IND. CONT. EQ. 447Y SP®	SPST isolated optically coupled transistor switch (will switch DC only); 50 mA maximum, 30 V DC maximum.	On-state saturation voltage less than 1 V at 2 mA, less than 1.3 mA at 50 mA. Off-state leakage current less than 10 µA.
PBOB (inactive)	210–250 V AC, 50/60 Hz			

Continued on page 25

Continued from page 24

Models	Input	Certifications	Output	Specifications
PBAM (inactive)	105–130 V AC, 50/60 Hz	  	8 V DC at 8 mA maximum (short circuit proof).	N/A
PBAQ	105–130 V AC, 50/60 Hz	 	SPST isolated solid-state switch; normally closed, ¼ A maximum (derated to ½ A at 70 °C). 10 A maximum inrush for one second or 30 A for one AC cycle (non repeating).  <div style="border: 1px solid gray; padding: 5px; background-color: #f0f0f0;"> <b>NOTE:</b> The output of the PBAQ will not conduct when power is removed from terminal #1 or #2.                     </div>	On-state voltage drop of less than 2.5 V AC at full load. Off-state leakage current less than 100 µA.

### PBA, PBB, PBD, and PBD-2 Power Blocks

The PBA, PBB, PBD, and PBD-2 power blocks are the most commonly used for AC operation. They are intended to switch the same AC voltage as is used to power the MULTI-BEAM sensor. However, the output of all four blocks is rated for 250 V AC maximum, and is able to switch a voltage which is different than the supply as long as both AC circuits share a common neutral. For example, a PBA could switch a 24 V AC door chime, etc. Observe local codes when mixing AC voltages in a wiring chamber.

The blocks are designed to handle the inrush current of AC inductive loads like motor starters and solenoids. The holding current specification of any inductive load should not exceed the 750 mA output rating. There is no minimum load requirement. The power blocks will interface directly to all AC programmable controller inputs. All contain built-in transient suppression to prevent false turn-on or damage from inductive loads and line spikes. Outputs of multiple power blocks may be wired in series or parallel for the AND logic function and the OR logic function.

Wiring of PBA, PBB, PBD, and PBD-2

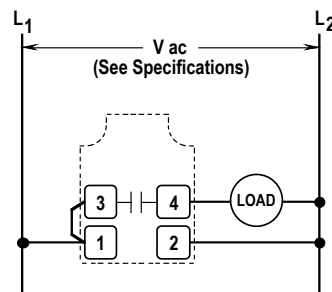

#### Wiring to Simple AC Load

The AC voltage is connected to terminals #1 and #2 to provide power to the MULTI-BEAM. The solid-state output switch behaves as if there were a contact between terminals #3 and #4. L1 is most conveniently applied to terminal #3 by jumpering terminals #1 and #3 inside the MULTI-BEAM.

The outputs of all five power block models are rated for 250 V AC maximum and can switch an AC voltage that is different from the supply as long as both AC circuits share a common neutral. Observe local wiring codes when mixing AC voltages in a common wiring chamber.

Because the output switch is a solid-state device, contact continuity cannot be checked by means of an ohmmeter, continuity tester, etc. To check the functioning of the output switch, a load must be installed and tested along with the MULTI-BEAM.



**CAUTION:** The output switch could be destroyed if the load becomes a short circuit (that is, if L1 and L2 are connected directly across terminals #3 and #4).

**NOTE:** Output switching capacity is ¼ A maximum.

See also "[Power Block \(AC\) General Wiring](#)" on page 28 for additional wiring setups.

### PBAT and PBBT Power Blocks

Power block models PBAT and PBBT have an isolated solid-state output switch which may be used to switch either AC or DC. The switch is rated at 100 mA maximum, and there is no capacity for inrush. As a result, these power blocks should not be used to switch AC inductive loads. However, 100 mA is enough capacity to switch many inductive DC loads like small relays and solenoids.

Models PBAT and PBBT interface directly to all AC programmable controller inputs.

**NOTE:** Because the saturation voltage of these power blocks is typically greater than 1 volt, they should not be used to interface 5 V DC logic circuits such as TTL. Instead, use special-order power block model PBOL or PBOBL.

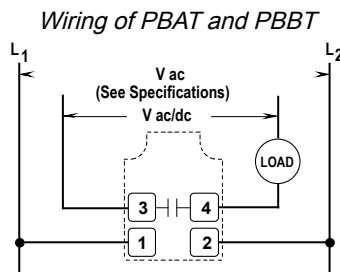

### PBA-1, PBB-1, and PBD-1 Power Blocks

The PBA-1, PBB-1, and PBD-1 power blocks are used to power emitter-only scanner blocks (models SBE, SBED, SBEX, SBEV, SBEXD, SBEF, SBEXF).

Models PBA-1, PBB-1, and PBD-1 save the cost of the output circuitry that must be included in other power block models (these other power blocks may, however, be used to power emitter-only scanner blocks, with the output switching circuitry going unused).

Emitter assemblies do not require logic modules.

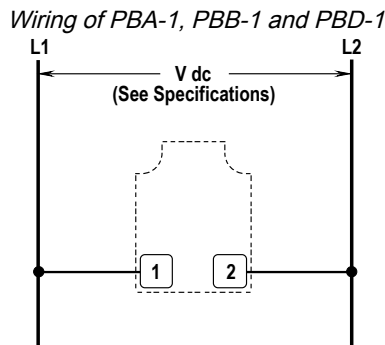

Wiring to AC Emitter--MULTI-BEAM emitter-only AC power blocks connect directly across the AC line. Emitter models: SBE, SBED, SBEX, SBEV, SBEXD, SBEF, and SBEXF.

## PBO and PBOB Power Blocks

The PBO and PBOB power blocks are designed to interface an electronic circuit (or control) at a low DC voltage level, but where there is no DC supply voltage available to power the MULTI-BEAM. Because the output is isolated it may be wired to either source or sink current, and multiple units may be wired in either series or parallel. The output of model PBO or PBOB will directly interface Banner component system logic modules.

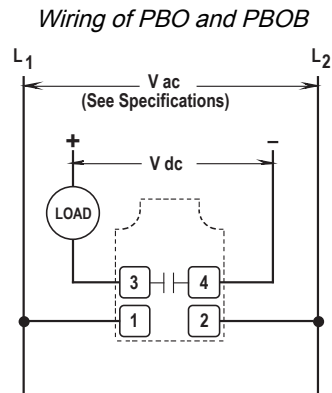

**NOTE:** The 1-volt saturation prevents direct interfacing to 5-volt logic systems such as TTL. For these low-voltage interfaces, use instead special order model PBOL or PBOBL.

*Wiring to Counter--*Power block models PBO and PBOB are designed to power the MULTI-BEAM with AC voltage and to permit the sensor output to interface with low-voltage DC circuits and devices. A common situation involves inputting to battery-powered LCD totalizers, rate meters, etc. The output switch is the transistor of an optical coupler, which may be connected to switch DC common to the count input. Polarity must be observed.

## PBAM Power Blocks

Model PBAM is a special-purpose power block that is powered by 120 V AC, and provides a low-level source of DC output voltage when the sensor's output is energized. It is used primarily to power low-voltage audio tone annunciators such as SONALERTS. The PBAM may also provide a signal to many types of logic devices.

The output is approximately 8 V DC when energized, and the output impedance is 1 K ohm (short circuit proof). The output is totally isolated from the AC supply voltage, and may be used to provide an input signal to many line-powered or battery-powered electronic totalizers.

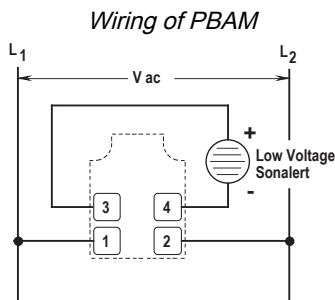

## PBAQ Power Blocks

Model PBAQ is identical to model PBA except that the solid-state output contact is normally closed instead of normally open. It is used where it is necessary to have the load de-energize when something is sensed (for example, one shot pulse to de-energize load). When no timing logic is involved, model LM3 can program any power block for normally open or normally closed operation via the light/dark operate jumper.

**NOTE:** Model PBAQ is not compatible with logic module models LM5 and LM5-14. For normally closed on-delay logic, use PBA with LM5R and reverse the light/dark function.

**NOTE:** The output of the PBAQ will not conduct when power is removed from terminal #1 or #2.

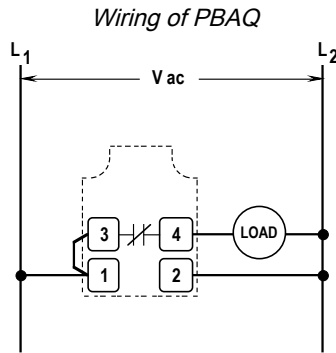

*Wiring to Simple AC Load*

The AC voltage is connected to terminals #1 and #2 to provide power to the MULTI-BEAM. The solid-state output switch behaves as if there were a contact between terminals #3 and #4. L1 is most conveniently applied to terminal #3 by jumpering terminals #1 and #3 inside the MULTI-BEAM.

The outputs of all five power block models are rated for 250 V AC maximum, and can switch an AC voltage which is different from the supply as long as both AC circuits share a common neutral. Observe local wiring codes when mixing AC voltages in a common wiring chamber.

Because the output switch is a solid-state device, contact continuity cannot be checked by means of an ohmmeter, continuity tester, etc. To check the functioning of the output switch, a load must be installed and tested along with the MULTI-BEAM.

 **CAUTION:** The output switch could be destroyed if the load becomes a short circuit (that is, if L1 and L2 are connected directly across terminals #3 and #4).

**NOTE:** Output switching capacity is 3/4 A maximum.

See also "Power Block (AC) General Wiring" on page 28 for additional wiring setups.

Power Block (AC) General Wiring

The diagram, titled "Wiring to a Simple AC Load", shows a power block with four terminals labeled 1, 2, 3, and 4. Terminals 1 and 2 are connected to a common neutral line. Terminals 3 and 4 are connected to a line labeled L1. A dashed line indicates a normally open contact between terminals 3 and 4. A load is connected between terminals 3 and 4. The AC voltage source is labeled V<sub>AC</sub> between lines L1 and L2. The power block models listed are PBA, PBB, PBD, PBD2, and PBAQ.

AC voltage is connected to terminals #1 and #2 to provide power to the MULTI-BEAM. The solid-state output switch behaves as if there were a contact between terminals #3 and #4. L1 is most conveniently applied to terminal #3 by jumpering terminals #1 and #3 inside the MULTI-BEAM.

The outputs of all five power block models are rated for 250 V AC maximum, and can switch an AC voltage which is different from the supply as long as both AC circuits share a common neutral. Observe local wiring codes when mixing AC voltages in a common wiring chamber.

Since the output switch is a solid-state device, contact continuity cannot be checked by means of an ohmmeter, continuity tester, etc. To check the functioning of the output switch, a load must be installed and tested along with the MULTI-BEAM.

**CAUTION:** The output switch could be destroyed if the load becomes a short circuit (i.e., if L1 and L2 are connected directly across terminals #3 and #4).

**NOTE:** This connection diagram depicts the output switch as a normally open contact. Model PBAQ actually has a normally closed output switch.

Continued on page 29

Continued from page 28

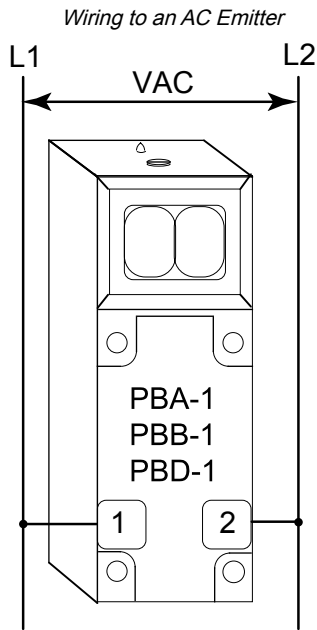

MULTI-BEAM emitter-only AC power blocks connect directly across the AC line, as shown.

Emitter models: SBE, SBED, SBEX, SBEV, SBEXD, SBEF, and SBEXF.

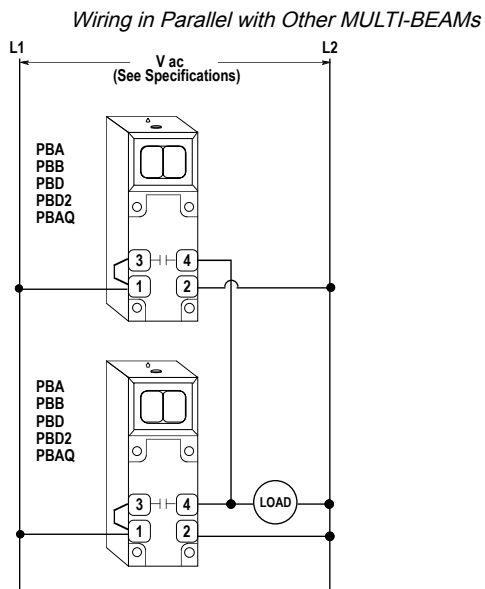

Any number of 3- and 4-wire MULTI-BEAM power block outputs may be connected in parallel to a load.

Parallel sensor connection is usually used to yield OR logic (that is, if an event occurs at any sensor, the load is energized). The total off-state leakage current through the load is the sum of the leakage current of the individual power blocks. However, the maximum leakage current of MULTI-BEAM 3- and 4-wire AC power blocks is only 100  $\mu$ A.

As a result, the installation of an artificial load resistor in parallel with the load is necessary only for a large number of sensors wired in parallel to a light load.

Continued on page 30

*Wiring in Series with Other MULTI-BEAMs*

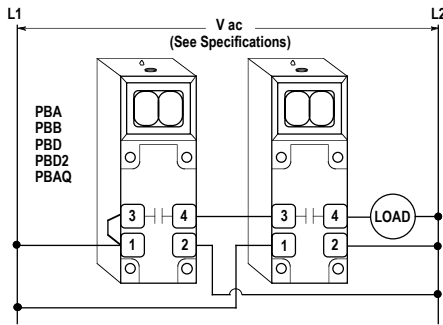

MULTI-BEAM 3- and 4-wire AC power blocks may be wired in series with each other for the AND logic function. The total voltage drop across the series will be the sum of the individual voltage drops across each power block (approximately 3 V per block).

With most loads, 10 or more power blocks may be wired in series.

*Wiring in Parallel with Contacts or Switches*

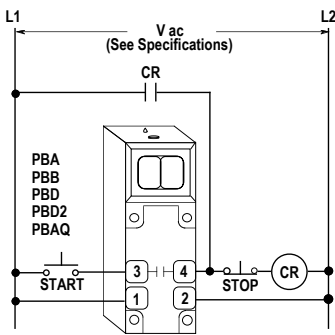

Any number of hard contacts may be wired in parallel with one or more MULTI-BEAM 3- and 4-wire power blocks.

All models have less than 100  $\mu$ A (0.1 mA) of off-state leakage current. The load operates when either the contacts close or the MULTI-BEAM output is energized.

*Wiring in Series with Contacts or Switches*

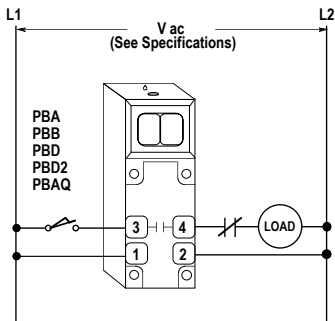

Terminals #3 and #4 of MULTI-BEAM 3- and 4-wire power blocks may be connected in series with one or more hard contacts.

The load operates only when all contacts are closed and the MULTI-BEAM output is energized.

*Wiring to a Programmable Logic Controller (PLC)*

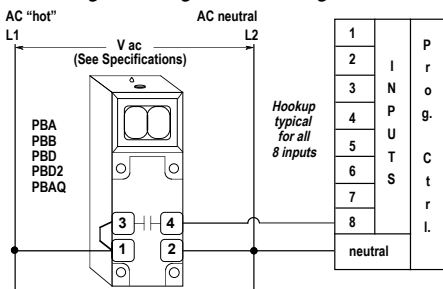

Interfacing to a PLC I/O is direct with MULTI-BEAM 3- and 4-wire AC power blocks. All models have less than 100  $\mu$ A (0.1 mA) of off-state leakage current.

If you have a question on wiring to a particular brand of PLC, contact Banner Engineering.

Continued from page 30

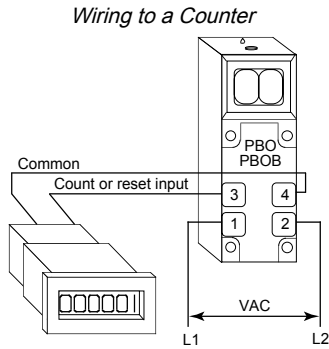

Power block models PBO and PBOB are designed to power the MULTI-BEAM with AC voltage and to permit the sensor output to interface with low-voltage DC circuits and devices.

A common situation involves inputting to battery-powered LCD totalizers, rate meters, etc.

The output switch is the transistor of an optical coupler, which may be connected to switch DC common to the count input. Polarity must be observed.

## Logic Modules

### Logic Modules (3- and 4-Wire) Models

In the table below, the signal represents the light condition (in LIGHT operate) or the dark condition (in DARK operate), and the output represents the energized condition of the solid-state output switch (power block). Delay refers to the time delay before the output operates, and hold refers to the time that the output remains on after the event has occurred.

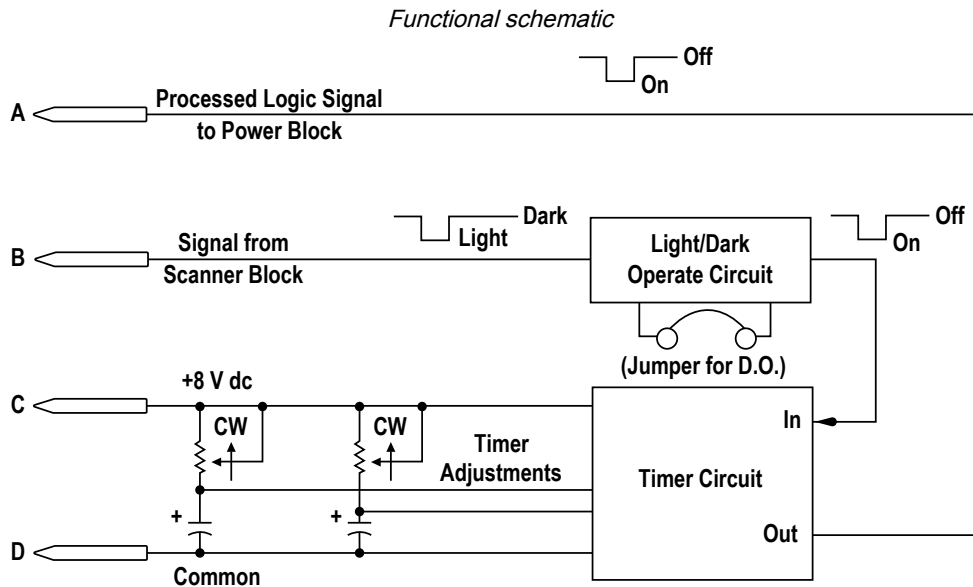

Model	Function	Description of Logic
LM1	<p><b>on-off</b></p>	<p>LM1 is an on-off logic modules that causes the power block output to follow the action of the scanner block: when the scanner block sees a LIGHT signal, the output is energized; when the scanner block sees a DARK signal, the output is de-energized. This is LIGHT operate mode. If the application calls for DARK operate mode, the LM1 may be used with normally-closed power blocks, such as PBAQ or PBT2.</p>
LM2	<p><b>alternate action</b></p>	<p>The LM2 provides flip-flop or toggling action of the power block output, such that each time the scanner block changes from a DARK state to a LIGHT state, the output changes state. The output remains in the last state until another change occurs. Some example applications for the LM2 are:</p> <ul style="list-style-type: none"> <li>• Operating a diverter gate that splits a production line into two lines</li> <li>• Operating room lighting by breaking a photoelectric beam                         <ul style="list-style-type: none"> <li>◦ If the lights are OFF, breaking the beam turns them ON</li> <li>◦ If the lights are ON, breaking the beam turns them OFF</li> </ul> </li> </ul>

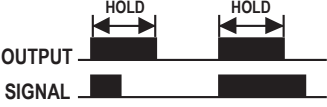
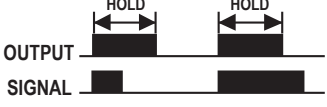
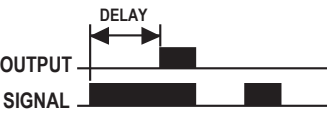
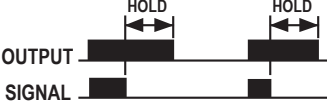
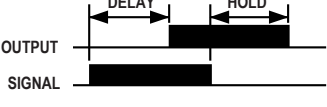
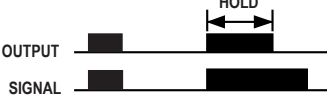

Continued on page 32

Continued from page 31

Model	Function	Description of Logic
LM3	<p style="text-align: center;"><b>on-off</b></p> 	<p>The LM3 is an on-off logic module that has the ability to be programmed for either LIGHT operate or DARK operate. It comes with a jumper wire installed: with the jumper in place, the output is DARK operated; with the jumper removed, the output is LIGHT operated. The LM3 is the most commonly used logic module when no timing function is desired, particularly if it is not known at the time of ordering which operate mode (LIGHT or DARK) will be needed.</p>
LM4-2	<p style="text-align: center;"><b>one-shot (retriggerable)</b></p>  <p style="text-align: center;">Setable time range: 0.1 to 1 second.</p>	<p>The LM4-2 provides a one-shot (or single-shot) output pulse each time there is a transition from LIGHT to DARK (jumper installed) or from DARK to LIGHT (jumper removed). The output pulse time range is from 0.01 seconds to 1 second. The duration of the pulse is independent of the duration of the input signal. The timing of the LM4-2 restarts each time that the input signal is removed and then reapplied. This is a retriggerable one shot. This feature may be applied to some rate sensing applications (use LM6-1 for true rate sensing).</p>
LM4-2NR	<p style="text-align: center;"><b>one-shot (non-retriggerable)</b></p>  <p style="text-align: center;">Setable time range: 0.1 to 1 second.</p>	<p>The LM4-2NR provides a one-shot (or single shot) output pulse each time there is a transition from LIGHT to DARK (jumper installed) or from DARK to LIGHT (jumper removed). The output pulse time range is from 0.01 seconds to 1 second. The duration of the pulse is independent of the duration of the input signal. The output pulse of the LM4-2NR must complete before it recognizes another input transition. This is called a non-retriggerable one shot, which sometimes offers an advantage in indexing or registration control applications where multiple input signals are possible during advance of the product.</p>
LM5	<p style="text-align: center;"><b>on-delay</b></p>  <p style="text-align: center;">Setable time range: 1.5 to 15 seconds.</p>	<p>The LM5 is a true on-delay logic module. The input signal must be present for a predetermined length of time before the output is energized. The output then remains energized until the input signal is removed. If the input signal is not present for the predetermined time period, no output occurs. If the input signal is removed momentarily, and then reestablished, the timing function starts over again from the beginning. A LIGHT/DARK operate selection jumper wire is included. The standard time range is 0.15 seconds to 15 seconds (field adjustable), and other ranges are available. The LM5 is often used to detect jams on a conveyor line, where a beam broken for longer than a preset period of time implies a product jammed in the light beam.</p>
LM5R	<p style="text-align: center;"><b>off-delay</b></p>  <p style="text-align: center;">Setable time range: 1.5 to 15 seconds.</p>	<p>The LM5R is an off-delay logic module, similar to the LM5, except that timing begins on the trailing edge of the input signal. When the input occurs, the output is immediately energized; if the input is then removed, the output remains energized for the adjustable predetermined time period, then de-energizes. If the input is removed but then re-established while the timing is holding the output energized, a new output cycle is begun. The LM5R can be used to tell when no products have broken a beam for a predetermined length of time, therefore indicating a jam or an empty reservoir upstream. A LIGHT/DARK operate selection jumper wire is included. Timing range is 0.15 seconds to 15 seconds, and optional ranges are available.</p>
LM5-14	<p style="text-align: center;"><b>on- &amp; off-delay</b></p>  <p style="text-align: center;">Setable time range: 1.5 to 15 seconds.</p>	<p>The LM5-14 combines the function of an on-delay and an off-delay into one logic module. When the signal is present for more than the on-delay time, the output energizes. The off-delay circuit is now active, and holds the output on even if the input signal disappears for short periods of time. If the input signal is gone for longer than the off-delay time, the output finally drops out. The most common use for the LM5-14 is to control fill level, for example in a bin: when the bin is full, a beam is broken, and a predetermined time later, the flow is stopped. After the level has fallen below the beam for a time, the flow is restarted. The time delays control the high and low levels. Each delay is independently adjustable for 0.15 seconds to 15 seconds.</p>
LM5T	<p style="text-align: center;"><b>limit timer</b></p>  <p style="text-align: center;">Setable time range: 1.5 to 15 seconds.</p>	<p>The LM5T limit timer combines the function of on-off logic and on-delay logic. As long as the signal is present for only short periods of time, the output follows the action of the input signal. If the input signal is present for longer than the predetermined time, the output de-energizes. The output only re-energizes when the input signal is removed and then reestablished. Interval timers are used to operate loads which must not run continuously for long periods of time, such as intermittent duty solenoids and conveyor motors. The LM5T may be used to run a supermarket checkout conveyor, always bringing the product up to the scanner beam and then stopping the motor. When the last item is removed, the motor times out and stops. Timing range is 0.15 seconds to 15 seconds.</p>

Continued on page 33

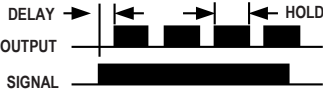
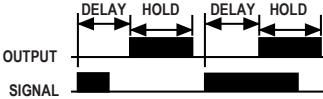
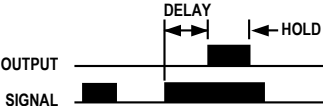
Continued from page 32

Model	Function	Description of Logic
LM6-1	<p style="text-align: center;"><b>rate sensor</b></p>  <p style="text-align: center;">Setable rate: 60 to 1200 pulses per minute.</p>	<p>The LM6-1 is a true overspeed or underspeed sensing logic module that monitors signals from a scanner block and continuously calculates the time between input signals, and compares that time with the reference set by the HOLD potentiometer. A jumper allows the mode to be changed from overspeed (jumper installed) to underspeed (jumper removed). In the overspeed mode, the output will drop if the preset rate is exceeded.</p> <p>In the underspeed mode, the output remains energized until the input rate drops below the preset. The output will not pulse at low speeds, as retriggerable one-shots do. A DELAY adjustment allows the LM6-1 to ignore data for the first several seconds after power is applied, to permit the rate to accelerate to operating speed without false underspeed outputs. The sensing rate may be adjusted from 60 pulses to 1200 pulses per minute (0.05 seconds to 1 second per pulse), and the power-up inhibit from 1 second to 15 seconds.</p>
LM8	<p style="text-align: center;"><b>repeat cycler</b></p>  <p style="text-align: center;">Setable time range: 1.5 to 15 seconds.</p>	<p>The LM8 is a repeat cycle timing module with independently adjustable delay and hold times. When an input signal is received from the scanner block, a delay period begins during which there is no output. If the signal remains, the delay period is followed by a hold period, during which the output is energized. If the signal still remains, the hold period times out, releasing the output and starting a new delay period. This sequence continues indefinitely until the input signal is removed. The LM8 is used in edgeguide and other registration control schemes where it is desired to pulse the correction motor to avoid overcorrection that might occur with a continuous output. Both time ranges are independently adjustable from 0.15 seconds to 15 seconds.</p> <div style="border: 1px solid gray; padding: 5px; text-align: center;"> <p><b>NOTE:</b> Use of the LIGHT/DARK operate jumper is reversed: remove for DARK, leave in place for LIGHT.</p> </div>
LM8-1	<p style="text-align: center;"><b>delayed one-shot</b></p>  <p style="text-align: center;">Setable time range: 1.5 to 15 seconds.</p>	<p>The LM8-1 is a delayed one-shot that functions like two individual one-shots, with the end of the first initiating the second. When an input signal occurs, a delay period is initiated, during which time the output is not energized. After the delay, the output is energized for the hold period, then de-energized. No further action takes place unless the signal is removed and then reestablished. This sequence is independent of the duration of the input signal. The LM8-1 is frequently used to sense a product, and then act on that product a short time later when it is clear of the inspection station. An example might be to inspect cartons for open flaps, and to eject the faulty cartons when they have completely passed the inspection point. Both time ranges are adjustable from 0.15 seconds to 15 seconds.</p>
LM8A	<p style="text-align: center;"><b>on-delay one-shot</b></p>  <p style="text-align: center;">Setable time range: 1.5 to 15 seconds.</p>	<p>The LM8A incorporates both a delay and a hold time, except that the delay is a true on-delay (this differs slightly from the LM8-1). If the input signal does not last for the total duration of the delay time, no output action occurs. If the delay time passes, the one-shot output occurs, regardless of what happens to the input signal. Removing the input signal and reapplying it begins a new cycle. The LM8A is used to eject a part that has remained in the sensor beam longer than the delay time (for instance, a jammed part). Both time ranges are independently adjustable from 0.15 seconds to 15 seconds.</p> <div style="border: 1px solid gray; padding: 5px; text-align: center;"> <p><b>NOTE:</b> Use of the LIGHT/DARK operate jumper is reversed: remove for DARK, leave in place for LIGHT.</p> </div>
LM10	<p style="text-align: center;"><b>÷10 counter</b></p> 	<p>The LM10 is a fixed-count divide-by-ten logic module, with neither timing nor LIGHT/DARK operate functions. When power is first applied, the output is OFF. With each dark-to-light transition, the LM10 enters one count in its memory. After five counts, the output is energized, and it remains energized until the tenth count. It then de-energizes, and the sequence continues. The LM10 is intended for product counting applications using programmable logic controllers (PLC) or computers, where the scan time of the input section of the controller is too slow to permit catching high speed count rates. It may also be used with electromechanical totalizers, which suffer from this same slow response. In operation, the registered count must be multiplied by ten to get the true count (ambiguity of five).</p>
LMT Test Logic		<p>LMT is a plug-in test logic module for use when troubleshooting MULTI-BEAM sensors. It contains LED indicator lights in place of the timing potentiometers and a miniature switch in place of the LIGHT/DARK operate jumper. The indicator lights display the operation of the scanner block and power block to verify proper functioning. The switch permits manual operation of the load to verify the output switching circuit. The step-by-step testing procedure included with the LMT allows a MULTI-BEAM to be completely tested without removing it from the installation, and, if there is a faulty scanner block, power block, or logic module, the LMT will identify it.</p>

## Logic Module Modifications

The time ranges of any MULTI-BEAM logic module may be factory modified. Time range modification is often necessary to improve the setability of the timing function. Some time range modifications are carried in stock. Other time range

modifications may be quoted. When ordering modified logic modules, add the letter M after the model number, followed by the maximum time desired (in seconds). The table below lists possible modifications.

Model Number Suffix	Setable Time Range
M.01	0.001 seconds to 0.01 seconds
M.1	0.01 seconds to 0.1 seconds
M.5	0.05 seconds to 0.5 seconds
M1	0.1 seconds to 1 second
M5	0.5 seconds to 5 seconds
M15	1.5 seconds to 15 seconds

- **For logic modules with a single timing function**, specify the maximum desired time in seconds (for example, LM5M5 indicates an LM5 on-delay with the delay time adjustable up to 5 seconds).
- **For logic modules with dual timing functions**, specify the maximum desired delay and hold time in seconds (for example, LM5-14M1M5 indicates an LM5-14 on-off delay with an on-delay adjustable up to 1 second and an off-delay adjustable up to 5 seconds). Always specify both timing ranges, even if only one is to be modified.
- **For fixed timing**, the letter F should always be followed by the desired time, in seconds (for example, LM5MF1 would be an LM5 on-delay with a fixed 1 second delay time). For fractions of seconds, use decimal equivalents, such as LM5MF.5, LM5MF.01, etc.

Chapter Contents

Scanner Blocks ..... 35  
 Power Block (2-wire) Models..... 41  
 Logic Modules (2-Wire) ..... 45

# Chapter 3 2-Wire Sensors

The components of the MULTI-BEAM 2-wire family of modular self-contained sensors are physically identical to the 3- & 4-wire components. However, the 2-wire components are designed to wire directly in series with an AC load, exactly like a limit switch. This design makes the 2-wire MULTI-BEAM impossible to wire backward.

MULTI-BEAM 2-wire scanner blocks with their 10-millisecond response time have approximately the same optical performance as the 1-millisecond 3- & 4-wire scanner block models.

The off-state leakage current of 2-wire MULTI-BEAM sensors is less than 1 milliamp, the lowest value of any 2-wire photoelectric sensor. This makes the MULTI-BEAM 2-wire photoelectric device the most probable device to interface directly with AC inputs of programmable logic controllers (PLCs).

## Scanner Blocks

MULTI-BEAM 2-wire sensors connect in series with an AC load, exactly like a heavy-duty limit switch. Models are offered in all sensing modes, including glass fiber optic. All have 10 ms on-off response time and built-in protection against false pulse on power-up.

The circuitry of all MULTI-BEAM components is encapsulated within rugged, corrosion-resistant PBT polyester housings that meet or exceed NEMA 1, 3, 12, and 13 ratings. MULTI-BEAM 2-wire scanner blocks include Banner's exclusive, patented Alignment Indicating Device (AID™) system, which lights a top-mounted LED when the sensor sees its modulated light source and pulses at a rate proportional to the strength of the received light signal.

## Scanner Block (2-Wire) Models

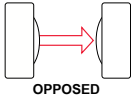
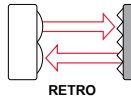
Models	Performance	Sensing Mode	Description
<b>SBE</b>			
<b>2SBR1</b>	<p><b>Range:</b> 45 m (150 ft)</p> <p><b>Response:</b> 10 ms on/off</p> <p><b>Repeatability:</b> 0.03 ms</p> <p><b>Beam:</b> infrared, 940 nm</p> <p><b>Effective Beam:</b> 25 mm (1 in) diameter</p>	 <p>OPPOSED</p>	<p>The 2SBR1 receiver model is used with the SBE emitter, the same emitter used with the 1 ms 3- &amp; 4-wire receiver model SBR1. The response time, however, is determined by the receiver, and is 10 ms. This pair will work reliably in slightly dirty (average manufacturing plant) conditions up to 18 m (60 ft) opposed, and outdoors up to 6.1 m (20 ft). When more distance (or excess gain) is required, use 3- &amp; 4-wire receiver model SBRX1 with the SBEX emitter. The 2SBR1 will not work with the visible emitter SBEV. Use opposed mode sensors as a first choice in any application, except where the material to be sensed is translucent to light or so small that it will not break the effective beam diameter. The SBE emitter uses a 3- &amp; 4-wire power block. Power blocks for use with SBE include models PBA-1, PBB-1, PBD-1, PBT-1, and PBT48-1 (see datasheet 03508).</p> <p><b>NOTE:</b> Users must purchase one emitter and one receiver for opposed mode sensors .</p>
<b>2SBL1</b>	<p><b>Range:</b> 2.5 cm to 9 m ( 1 in to 30 ft)</p> <p><b>Response:</b> 10 ms on/off</p> <p><b>Repeatability:</b> 2.5 ms</p> <p><b>Beam:</b> infrared, 940 nm</p>	 <p>RETRO</p>	<p>Model 2SBL1 is the retroreflective mode scanner block in the 2-wire MULTI-BEAM family. It has the same excellent optical performance as model SBL1 in the 3-&amp; 4-wire family. If the application calls for breaking a retroreflective beam with shiny objects such as metal cans or cellophane-wrapped packages, mount the 2SBL1 and its retroreflector at an angle of 10 degrees or more to the shiny surface to eliminate an direct reflections from the object itself, or consider using 3- &amp; 4-wire scanner block model SBLVAG1. Alternatively, the MAXI-BEAM, VALU-BEAM, and MINI-BEAM families offer 2-wire AC visible and polarized retroreflective models. The gain falls off at very close sensing ranges, so much so that retroreflectors cannot be used reliably closer than one inch from the sensor.</p>

Continued on page 36

Continued from page 35

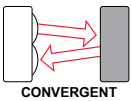
Models	Performance	Sensing Mode	Description
2SBC1	<b>Focus at:</b> 38 mm (1.5 in) <b>Response:</b> 10 ms on/off <b>Repeatability:</b> 2.5 ms <b>Beam:</b> infrared, 940 nm	 <p>CONVERGENT</p>	<p>These convergent mode 2-wire scanner blocks are identical in performance to their 3- &amp; 4-wire equivalents, except for the 10 ms response time. They are designed for 2-wire applications where background objects might be seen by proximity mode sensors, or where the precision of a small focused image is important (for example, edge-guiding or position control).</p> <p>Model 2SBC1 provides much more excess gain at its focus point as compared to the diffuse mode sensors. Convergent mode sensors are preferable to diffuse mode sensors if the distance from the sensor to the object to be detected can be kept constant. Models 2SBC1 and 2SBC1-4 may be derived from retro model 2SBL1 by exchange of the upper cover assembly. Model 2SBC1 uses upper cover UC-C, and model 2SBC1-4 uses upper cover model UC-C4.</p> <p>These may be interchanged. A 152 mm (6 in) convergent model may be created from either model by substituting upper cover UC-C6.</p>
	<b>Focus at:</b> 10 cm (4 in) <b>Response:</b> 10 ms on/off <b>Repeatability:</b> 2.5 ms <b>Beam:</b> infrared, 940 nm		
2SBD1	<b>Range:</b> 30 cm (12 in) <b>Response:</b> 10 ms on/off <b>Repeatability:</b> 2.5 ms <b>Beam:</b> infrared, 880 nm	 <p>DIFFUSE</p>	<p>Models 2SBD1 and 2SBDX1 diffuse (proximity) mode scanner blocks are identical except for their lenses. Model 2SBD1 uses upper cover model UC-D, and the 2SBDX1 uses UC-L. While the UC-L lens extends the range to over 762 mm (30 in), it creates a dip in the excess gain at closer ranges. As a result, the 2SBDX1 may sense a dark colored object at 254 mm (10 in), but it may not see it at all at 51 mm (2 in).</p> <p>If the application is not completely defined, either scanner block may be ordered, along with the complementary upper cover as an accessory.</p>
2SBDX1	<b>Range:</b> 76 cm (30 in) <b>Response:</b> 10 ms on/off <b>Repeatability:</b> 2.5 ms <b>Beam:</b> infrared, 880 nm		

Continued on page 37

Continued from page 36

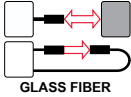
Models	Performance	Sensing Mode	Description
2SBF1	<p><b>Range:</b> see Performance Curves</p> <p><b>Response:</b> 10 ms on/off</p> <p><b>Repeatability:</b> 2.5 ms</p> <p><b>Beam:</b> infrared, 880 nm</p>		<p>Scanner block 2SBF1 combines the simplicity of 2-wire configuration with the sophistication and versatility of optical fibers. The infrared source of this model will work with any Banner glass fiber optic assembly, except bifurcated assemblies with bundle diameters less than 1.59 mm (1/16 in). Since fibers are frequently used for sensing small parts, fast response time is often a consideration.</p> <p>If the application requires response near the 10 ms specification of the 2SBF1, consider the faster 3- &amp; 4-wire model SBF1. <i>For complete information on glass fiber optic assemblies, see <a href="http://www.bannerengineering.com">www.bannerengineering.com</a>.</i></p> <p>The following fiber optic cables and lenses are commonly used with the model 2SBF1 scanner block:</p> <p><b>IT13S:</b> Individual assembly 1.5 mm (0.06 in) diameter fiber bundle</p> <p><b>IT23S:</b> Individual assembly 3 mm (0.12 in) diameter fiber bundle</p> <p><b>L9:</b> 12 mm (0.5 in) diameter lens</p> <p><b>L16F:</b> 25 mm (1.0 in) diameter lens</p> <p><b>BT13S:</b> Bifurcated assembly 1.5 mm (0.06 in) diameter fiber bundles</p> <p><b>BT23S:</b> Bifurcated assembly 3 mm (0.12 in) diameter fiber bundles</p>

### Scanner Block (2-Wire) Performance Curves

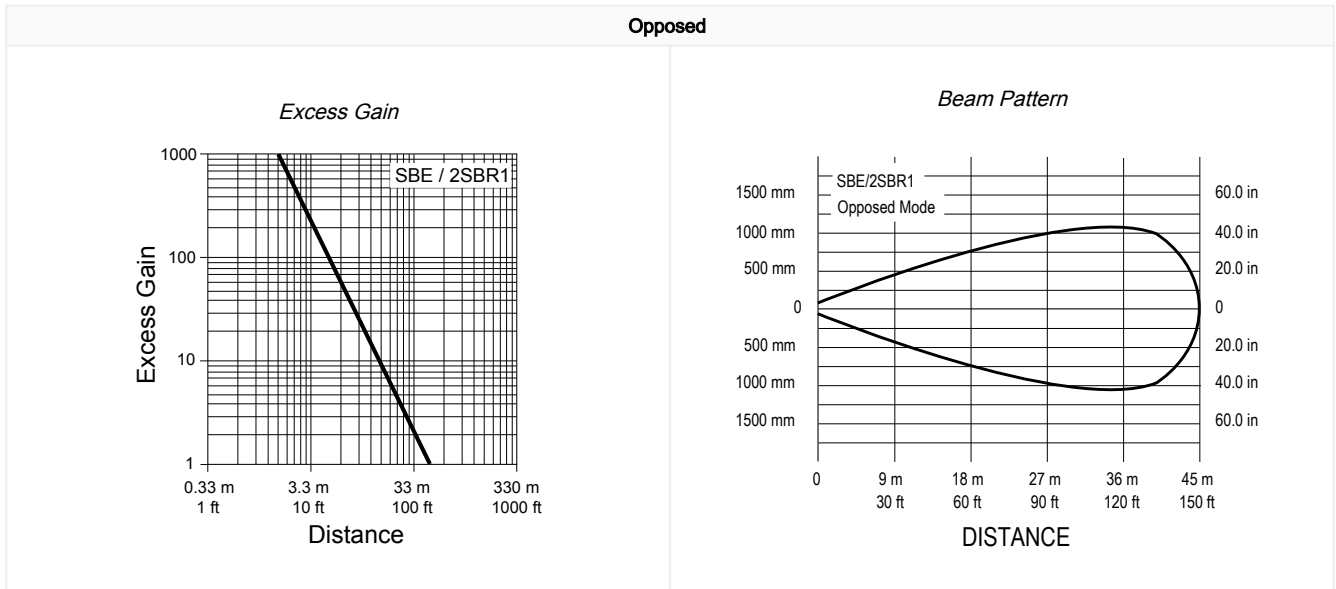

**Retroreflective**

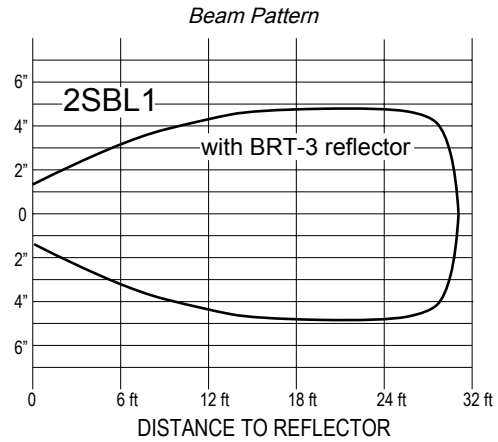
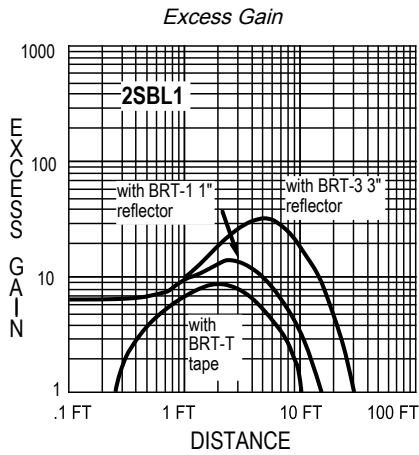

**Convergent**

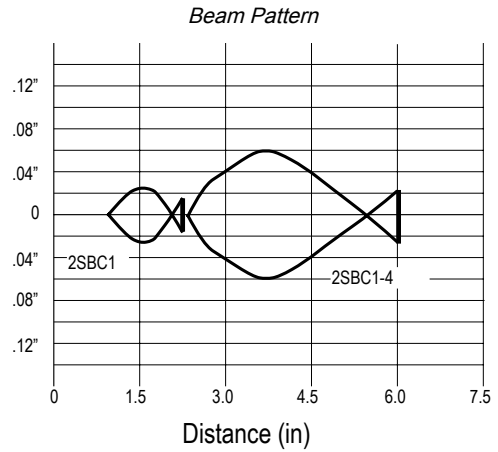
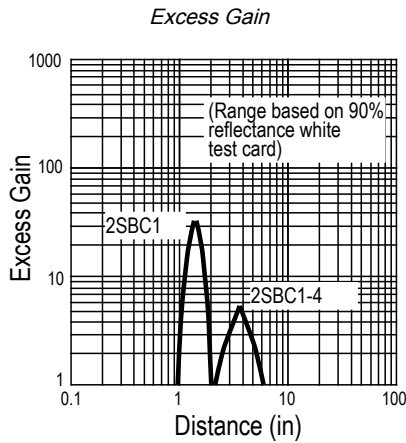

**Diffuse**

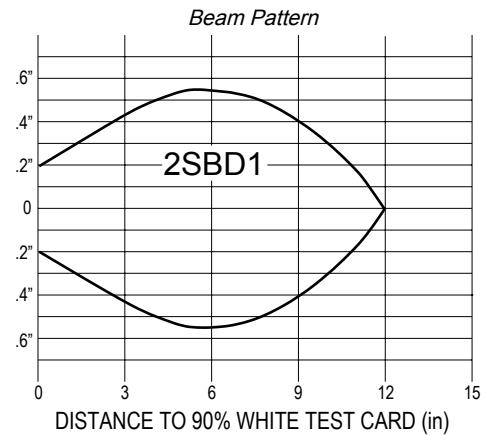
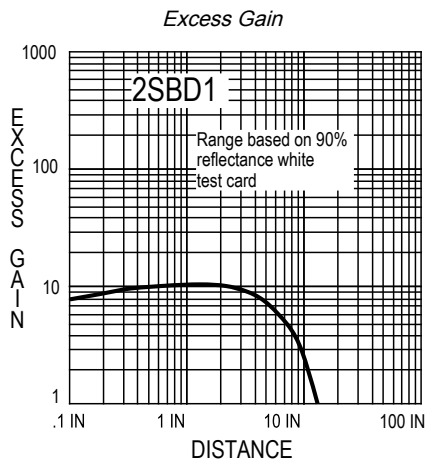

Continued on page 39

Continued from page 38

**Diffuse**

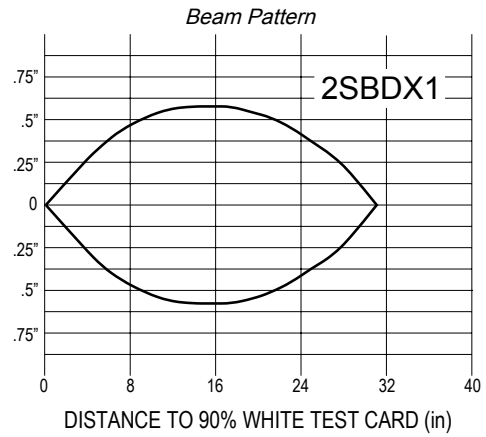
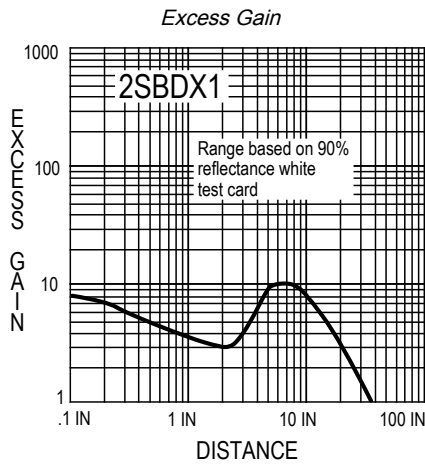

**Fiber Optic (glass fibers)**

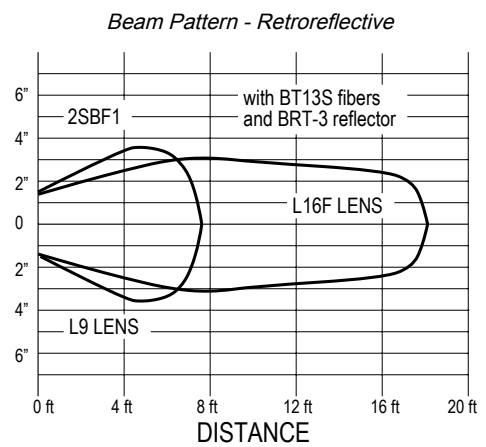
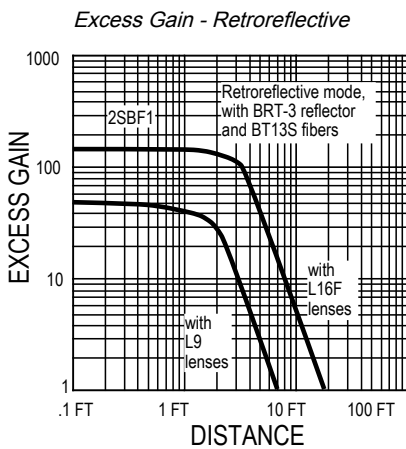
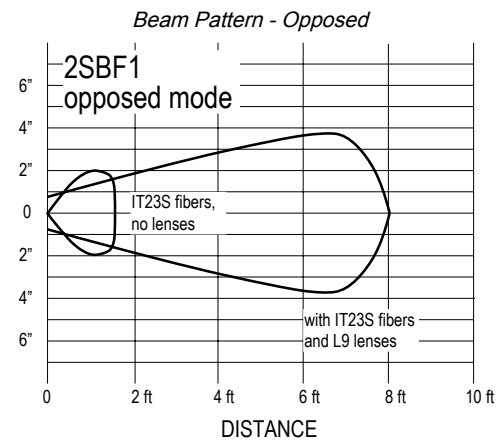
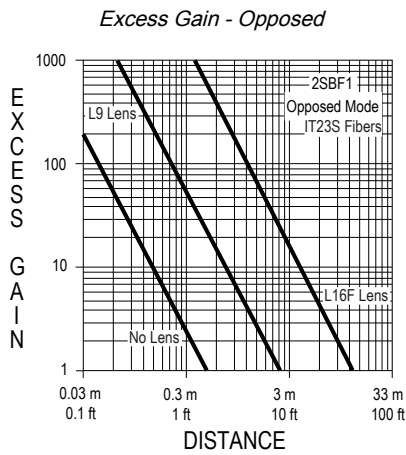

Continued on page 40

Continued from page 39

Fiber Optic (glass fibers)

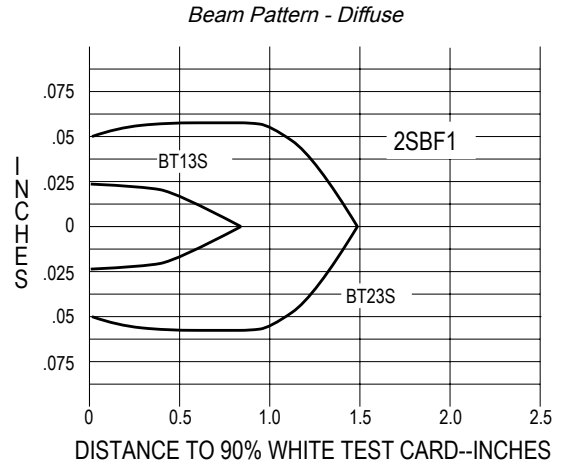
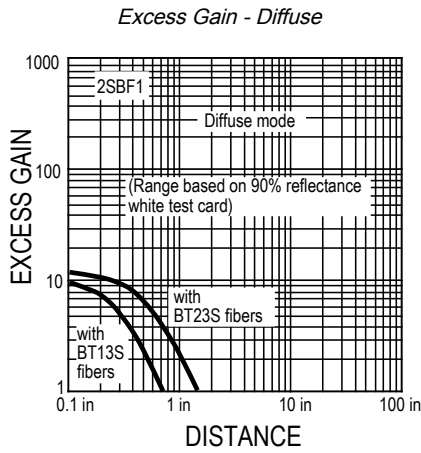

### Scanner Block (2-Wire) Wiring

Basic Wiring of 2-Wire MULTI-BEAM

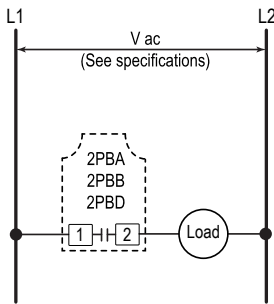

MULTI-BEAM 2-wire sensors wire in series with an appropriate load. This combination, in turn, wires directly across the AC line. A 2-wire sensor may be connected exactly like a mechanical limit switch.

The MULTI-BEAM remains powered when the load is off by a residual current that flows through the load. This off-state leakage current is always less than 1 mA. The effect of this leakage current depends upon the characteristics of the load. The voltage that appears across the load in the off-state is equal to the leakage current of the sensor multiplied by the resistance of the load:  $V_{off} = 1 \text{ mA} \times R_{load}$ .

If this resultant off-state voltage is less than the guaranteed turn-off voltage of the load, the interface is direct. If the off-state voltage causes the load to stay on, connect an artificial load resistor in parallel with the load to lower its effective resistance. Most loads, including most programmable logic controller (PLC) inputs, will interface to 2-wire sensors with 1 mA leakage current without needing an artificial load resistor. There is no polarity requirement. Either wire may connect to terminal #1 and the other to terminal #2.



**CAUTION:** All three components of a MULTI-BEAM 2-wire sensor will be destroyed if the load becomes a short circuit.

Functional Schematic

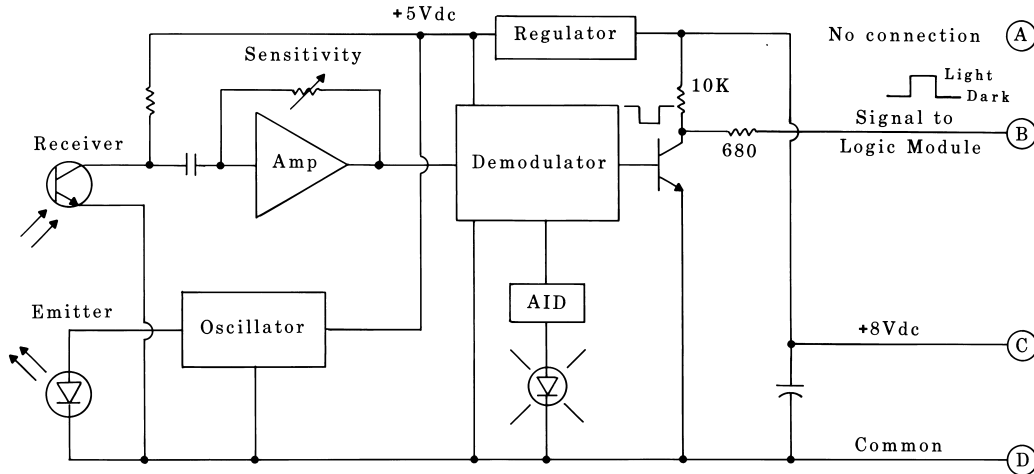

## Power Block (2-wire) Models

MULTI-BEAM 2-wire power block models 2PBA, 2PBB, and 2PBD contain a low-voltage power supply that uses a unique circuit to take a very small leakage current through the load and convert it to the dc power required to run the scanner block and logic module. They also contain the solid-state switch that operates the load, and a transient suppression circuit to prevent false operation from high voltage spikes on the incoming line. They are completely solid-state for unlimited operating life.

Model 2PBR is a 4-wire power block that works with 2-wire scanner blocks and logic modules and offers an SPST "hard" contact for switching heavy AC or DC loads. Model 2PBR2, also for use with 2-wire scanner blocks and logic modules, uses a 3- or 4-wire connection with SPDT "hard" contacts for switching heavy AC loads. NOTE: MULTI-BEAM 2-wire AC power blocks are color-coded black.

Models	Operating Voltage	Outputs	Specifications	Certifications
2PBA	105 to 130 V AC; 50/60 Hz	SPST solid-state switch, 3/4 amp maximum (derated to 1/2 amp at 70 °C). 10 amps maximum inrush for 1 second (non-repeating).	On-State Voltage Drop: Less than 10 V Leakage Current: Less than 1 mA (resistive or inductive loads)	
2PBB (inactive)	210 to 250 V AC; 50/60 Hz			
2PBD (inactive)	22 to 28 V AC; 50/60 Hz			N/A
2PBR	105 to 130 V AC; 50/60 Hz	SPST electromechanical relay contact.	Contact Rating: 250 V AC max, 30 V DC max, 5 amps max (resistive load); install MOV across contact if switching an ac inductive load. Closure time: 20 ms Release time: 20 ms Maximum Switching Speed: 20 operations/second Mechanical Life: 10,000,000 operations	N/A

## Power Block (2-Wire) Wiring Diagrams

### 2PBA, 2PBB, and 2PBD Power Blocks

MULTI-BEAM 2-wire power blocks wire directly in series with an AC load, exactly like a limit switch. The response time of 2-wire power blocks is determined by the scanner block, whose response time is 10 ms on/off. A built-in false pulse protection circuit holds the output OFF for 10 ms after power is initially applied to the power block. MULTI-BEAM 2-wire power blocks

will operate from  $-40$  to  $70$  °C ( $-40$  to  $158$  °F). Resistive loads must be less than 15,000 ohms and inductive loads must be greater than 1.2 watts (10 mA).

**NOTE:** Output has a maximum load capacity of 3/4 A, a maximum resistive load of 15 kOhms, and a minimum inductive load of 1.2 watts (10 mA).

*Functional Schematics*

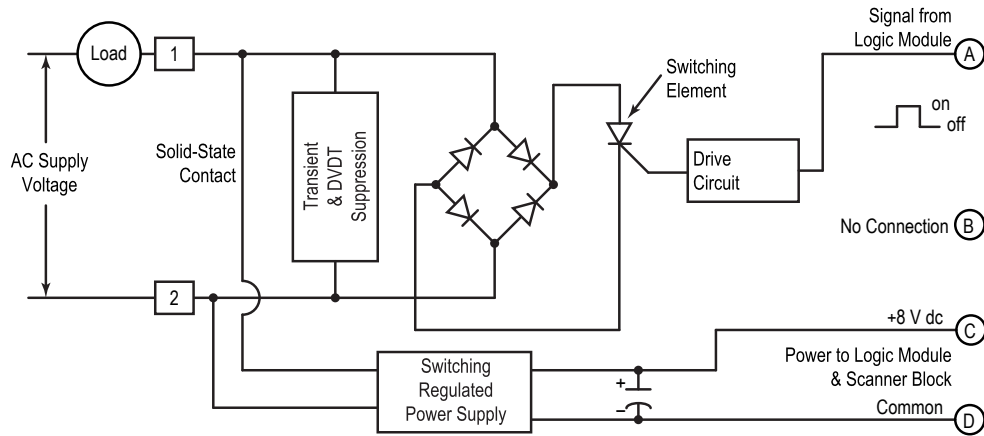

**2PBR and 2PBR2 Power Blocks**

Model 2PBR actually requires a 4-wire connection and model 2PBR2 requires a 3- or 4-wire connection, even though they only work with 2-wire scanner blocks and logic modules. Both are powered by 120 V AC across terminals #1 and 2. The 2PBR offers an SPST "hard" relay contact between terminals #3 and 4.

Model 2PBR2 is an SPDT version, with both contacts common to terminal #1: terminal #3 is a normally open output, and terminal #4 is normally closed. These configurations allow MULTI-BEAM sensors to directly interface large loads which draw more than 3/4 amp like clutches, brakes, large contactors, and small motors.

Model 2PBR can switch both AC and DC loads; model 2PBR2 switches the AC line voltage to an AC load (see connection diagrams). The 2PBR and 2PBR2 also eliminate the problem of voltage drop from series strings of sensors operating low-voltage AC loads.

Install an appropriate value MOV (metal oxide varistor) transient suppressor across the power block relay contacts when switching an AC inductive device.

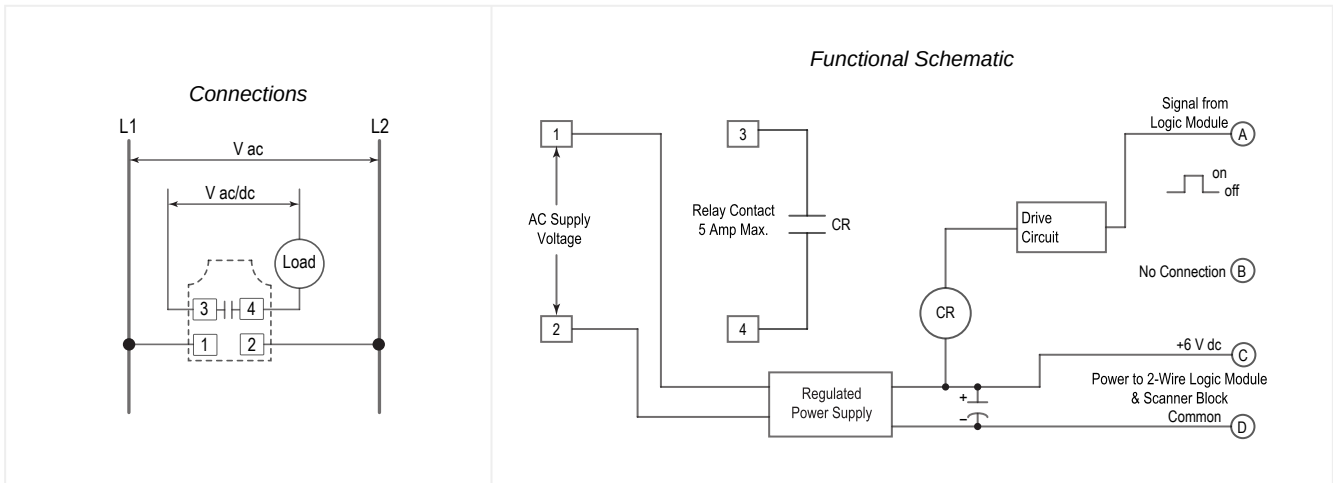

Continued on page 43

Continued from page 42

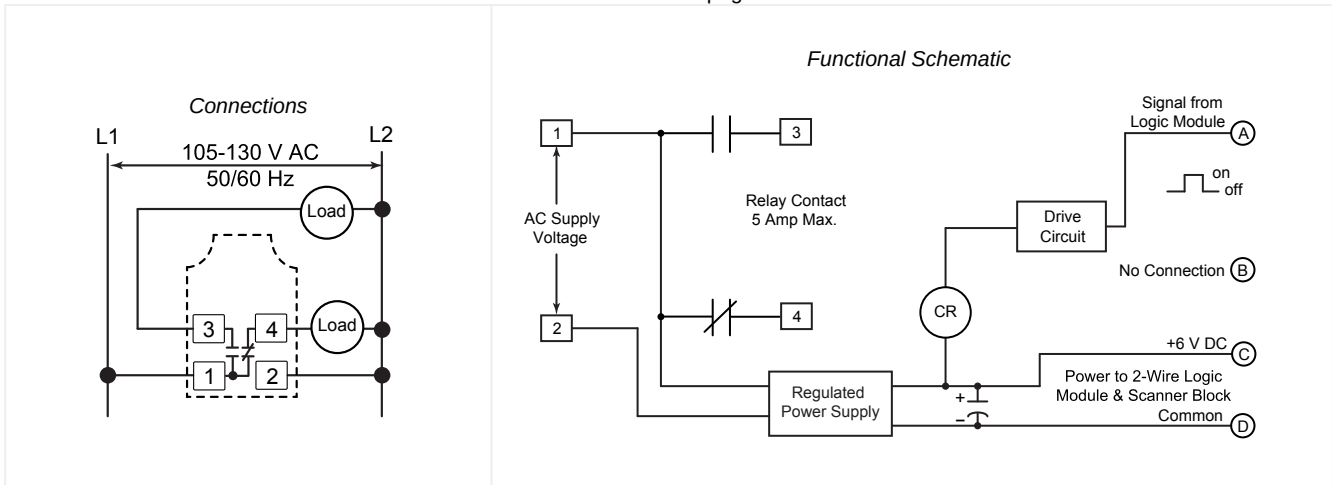

### Power Block (2-Wire) General Wiring

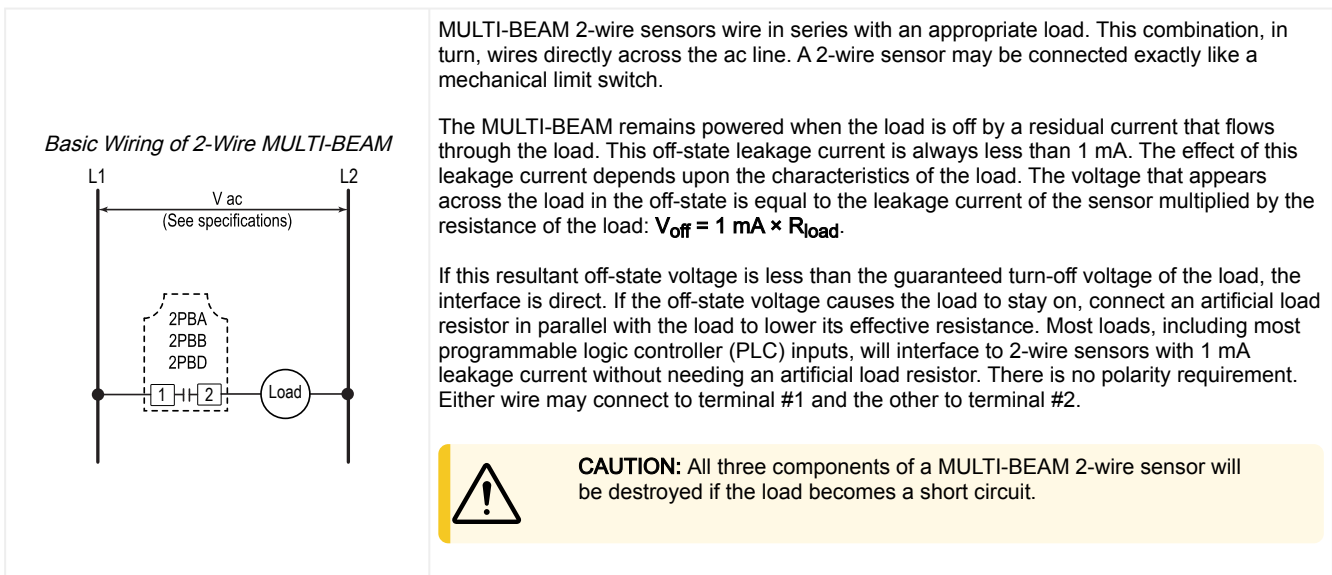
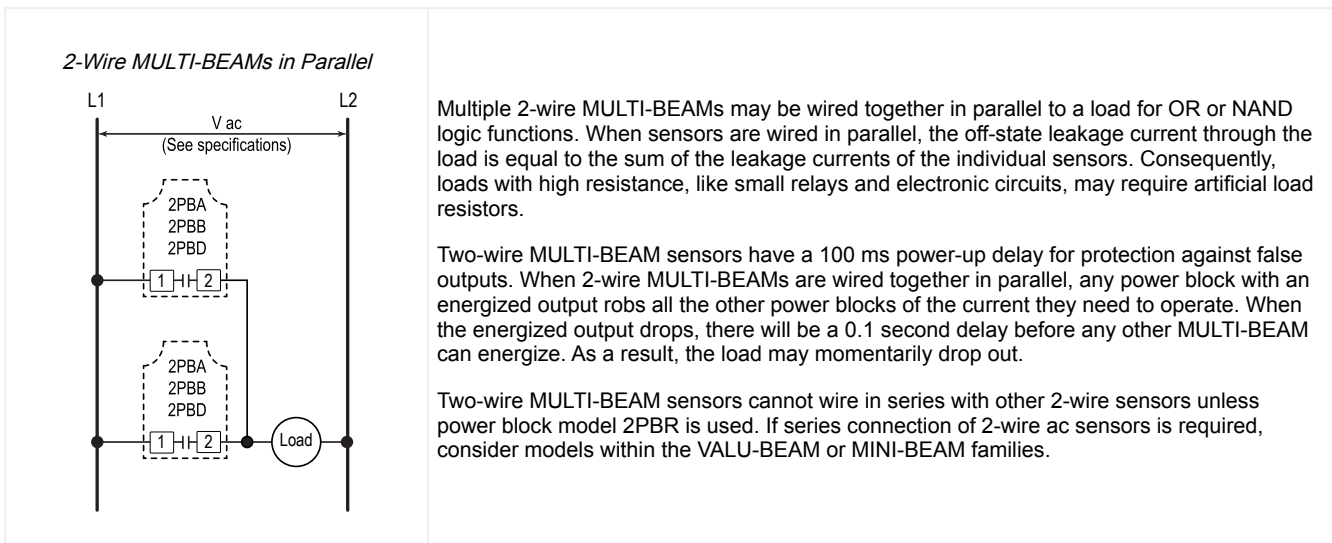

**2-Wire MULTI-BEAM with Series Contacts**

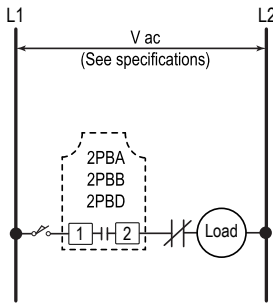

When 2-wire MULTI-BEAM sensors are connector in series with mechanical switch or relay contacts, the sensor receives power to operate only when all the contacts are closed.

The false-pulse protection circuit of the MULTI-BEAM causes a 0.1 second delay between the time that the last contact closes and the time that the load energizes.

**2-Wire MULTI-BEAM with Parallel Contacts**

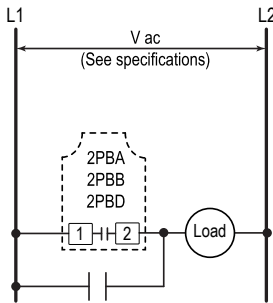

Two-wire MULTI-BEAM sensors may be wired in parallel with mechanical switch or relay contacts. The load energizes when any of the contacts close or the sensor output is energized.

When a contact is closed, it shunts the operating current away from the MULTI-BEAM.

As a result, when all the contacts are open, the MULTI-BEAM's 0.1 second power-up delay may cause a momentary drop-out of the load.

**Photoelectric Latch with Manual Reset**

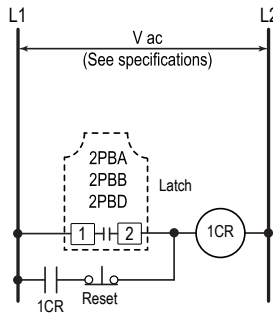

The 1CR relay will latch on whenever the 2-wire MULTI-BEAM output is energized.

The 1CR is reset when the normally-closed button switch is pressed.

**2-Wire MULTI-BEAM to Programmable Logic Controller (PLC)**

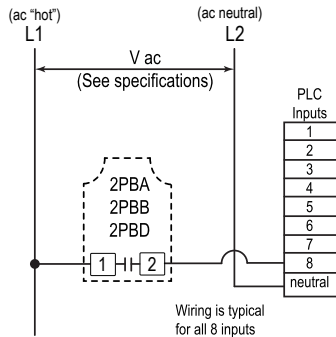

MULTI-BEAM 2-wire sensors operate with very low (1 mA) off-state leakage current. As a result, they will interface directly to most PLCs without needing an artificial load resistor.

If the off-state voltage (1 mA × the input resistance of the PLC) is higher than the PLC sensing threshold, install a 10 kOhm to 15 kOhm, 5-watt resistor for each 2-wire sensor. The resistor connects between the input terminal and ac neutral.

If you have a question about wiring a specific brand of PLC, contact the Banner Applications Department during normal business hours.

# Logic Modules (2-Wire)

The logic module interconnects the power block and scanner block both electrically and mechanically using a unique blade-and-socket connector concept. It also provides the LIGHT/DARK operate function (except in the LM1) and the timing functions, all of which are fully adjustable.

All MULTI-BEAM 2-wire logic modules are color-coded black, and are for use only in MULTI-BEAM 2-wire sensors. The time ranges specified for the logic modules are standard time ranges. For additional time ranges, see ["MULTI-BEAM 3- and 4-Wire Scanner Block Modifications"](#) on page 18.

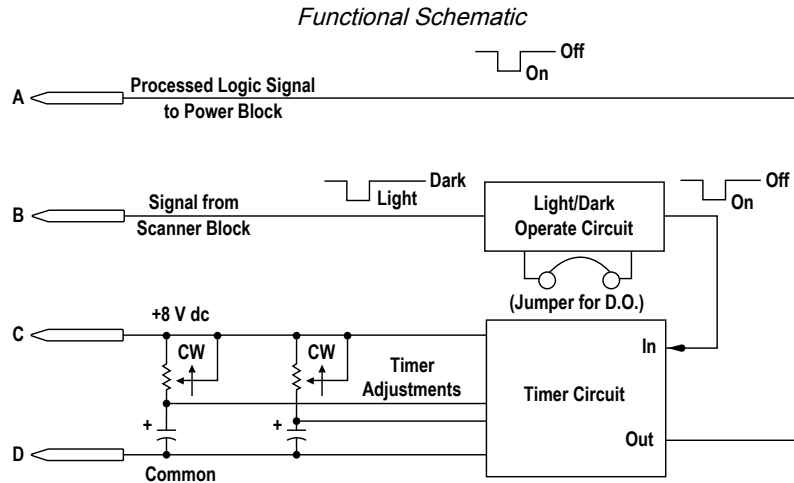



## Logic Module (2-Wire) Models

In the table below, the signal represents the light condition (in LIGHT operate) or the dark condition (in DARK operate), and the output represents the energized condition of the solid-state output switch (power block). Delay refers to the time delay before the output operates, and hold refers to the time that the output remains on after the event has occurred.

Model	Function	Description
2LM3	<p style="text-align: center;"><b>on-off</b></p>	The 2LM3 is an on/off logic module that has the ability to be programmed for either LIGHT or DARK operate. It comes with a jumper wire installed. With the jumper in place, the output is DARK operate; with the jumper removed, the output is LIGHT operate. Use the 2LM3 when no timing function is desired.
2LM4-2 (inactive)	<p style="text-align: center;"><b>one-shot (retriggerable)</b></p> <p style="text-align: center;">Setable time range: 0.1 to 1 second.</p>	The 2LM4-2 provides a one-shot (single shot) pulse each time there is a transition from LIGHT to DARK (jumper installed) or from DARK to LIGHT (jumper removed). The output pulse time range is from 0.01 seconds to 1 second. The duration of the output pulse is independent of the duration of the input signal. The timing of the 2LM4-2 restarts each time the input signal is removed and then reapplied. This is referred to as a retriggerable one-shot, and this feature may be applied to some rate sensing applications.
2LM5	<p style="text-align: center;"><b>on-delay</b></p> <p style="text-align: center;">Setable time range: 1.5 to 15 seconds.</p>	The 2LM5 is a true on-delay logic module. The input signal must be present for a predetermined length of time before the output is energized. The output then remains energized until the input signal is removed. If the input signal is not present for the predetermined time period, no output occurs. If the input signal is removed momentarily and then reestablished, the timing function starts over again from the beginning. The standard time range is 0.15 seconds to 15 seconds (field adjustable), and other ranges are available.

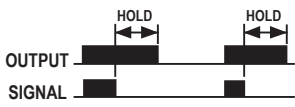
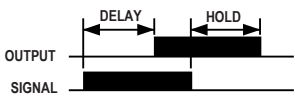
Continued on page 46

Model	Function	Description
2LM5R	<p style="text-align: center;"><b>off-delay</b></p>  <p style="text-align: center;">Setable time range: 1.5 to 15 seconds.</p>	<p>The 2LM5R is an off-delay logic module, similar to the 2LM5, except that timing begins on the trailing edge of the input signal. When the input occurs, the output is immediately energized; if the input is then removed, the output remains energized for the adjustable predetermined time period, then de-energizes. If the input is removed but then reestablished while the timing is holding the output energized, a new output cycle is begun. The LIGHT/DARK operate jumper wire option is included. Timing range is 0.15 seconds to 15 seconds, and optional ranges are available.</p>
2LM5-14	<p style="text-align: center;"><b>on- &amp; off-delay</b></p>  <p style="text-align: center;">Setable time range: 1.5 to 15 seconds.</p>	<p>The 2LM5-14 combines the function of an on-delay and an off-delay into one logic module. When the signal is present for more than the output on-delay time, the output energizes. The off-delay circuit is now active, and holds the output on even if the input signal disappears for short periods of time. If the input signal is gone for longer than the off-delay time, the output finally drops out. The time delays can control high and low levels in flow control applications. Each delay is independently adjustable for 0.15 seconds to 15 seconds.</p>
2LM5T (inactive)	<p style="text-align: center;"><b>limit timer</b></p>  <p style="text-align: center;">Setable time range: 1.5 to 15 seconds.</p>	<p>The 2LM5T limit timer combines the function of on/off logic and on-delay logic. As long as the signal is present for only short periods of time, the output follows the action of the input signal. If the input signal is present for longer than the predetermined time, the output de-energizes. The output re-energizes only when the input signal is removed and then reestablished. Interval timers are used to operate loads which must not run continuously for long periods of time, such as intermittent duty solenoids and conveyor motors. Timing range is 0.15 seconds to 15 seconds.</p>
LMT Test Logic		<p>Model LMT is a plug-in test logic module for use in troubleshooting MULTI-BEAM sensors. It contains LED indicator lights in place of the timing potentiometers and a miniature switch in place of the LIGHT/DARK operate jumper. The indicator lights display the operation of the scanner block and power block to verify proper functioning, and the switch permits manual operation of the load to verify the output switching circuit. The step-by-step testing procedure included with the LMT allows a MULTI-BEAM to be completely tested without removing it from the installation, and if there is a faulty scanner block, power block, or logic module, the LMT identifies it.</p>

Chapter Contents

Accessories and Replacement Parts for the MULTI-BEAM Family..... 47  
 Banner Engineering Corp Limited Warranty..... 49  
 Contact Us..... 49

# Chapter 4 Product Support

## Accessories and Replacement Parts for the MULTI-BEAM Family

An **upper cover** consists of the optical element for the MULTI-BEAM that is built into a gasketed cover for the upper portion of the scanner block. Upper covers may be ordered as replacement parts or for modifying the optical response of a particular model scanner block. The following upper cover assemblies are standard and stocked. Other special variations may be quoted. Stainless steel hardware is included with each cover.

*Upper covers*

Model	Description
UC-C	1.5 inch (38 mm) focus, glass lenses
UC-C4	4 inch (10 cm) focus, glass lenses
UC-C6	6 inch (15 cm) focus, glass lenses
UC-D	Flat vinyl lens for short range and/or wide beam angle. Used on: SBD1 SBED SBRD1 SBEXD SBRXD1 2SBD1
UC-DMB	MB = Modified with Baffle; for short-range proximity mode with SBDX1. Used on SBDX1MD
UC-F	Fits all Banner fiberoptic assemblies. Used on: SBF1, SBF1MHS, SBFX1, SBFV1, 2SBF1.
UC-EF	For fiberoptic emitter-only scanner blocks. Used on: SBEF SBEXF
UC-RF	For fiberoptic receiver-only scanner blocks. Used on: SBRF1 SBRXF1 SBAR1GHF
UC-L	Used on: SBE SBEV SBEX SBR1 SBRX1 SBL1 SBLV1, SBLX1, SBDL1, SBDX1, SBAR1, SBAR1GH, 2SBR1, 2SBL1, 2SBDX1, 3GA5-14, EM3T-1M, R1T3
UC-LAG	Anti-glare (polarizing) filter for retroreflective sensing of shiny objects. Used on SBLVAG1

*Special upper covers used in special sensing environments*





Model	Description
UC-DJ	Identical to UC-D, but with addition of plastic dust cover to prevent accumulation of dust/dirt in lens area.
UC-LJ	Adds plastic dust cover to UC-L. Used when sensor is mounted facing up (used to prevent dust/dirt buildup on lens).
UC-LG	Replaces UC-L in sensing locations where highly caustic materials are present (e.g. acid vapor or splash). Glass lens.

*Lower covers for all MULTI-BEAM scanner blocks*

Model	Description
LCMB	Standard replacement cover for all scanner blocks. Includes gaskets and four stainless steel mounting screws.
LCMBMTA	"MTA" = Modified Timing Access. Gasketed nylon screw covers for logic module timing adjustments. Includes gaskets and four stainless steel mounting screws.

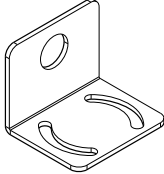
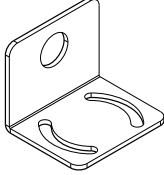
Mounting brackets

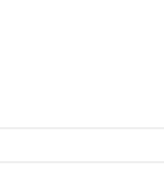
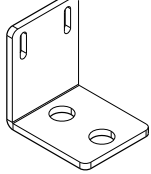
## MULTI-BEAM Sensors Family

<p><b>SMB700</b></p> <ul style="list-style-type: none"> <li>• Right-angle mounting bracket</li> <li>• 11 gauge zinc-plated steel</li> <li>• 70 mm wide by 60 mm deep x 60 mm high</li> <li>• Includes a cable gland assembly and lock washer</li> </ul>	
<p><b>SMB700SS</b></p> <ul style="list-style-type: none"> <li>• Right-angle mounting bracket</li> <li>• 11 gauge stainless steel</li> <li>• 70 mm wide by 60 mm deep x 60 mm high</li> </ul>	
<p><b>SMB700F</b></p> <ul style="list-style-type: none"> <li>• Flat mounting bracket</li> <li>• 11 gauge stainless steel</li> <li>• 70 mm x 110 mm</li> </ul>	
<p><b>SMBLS</b></p> <ul style="list-style-type: none"> <li>• Two-part bracket assembly that allows adjustment in three directions</li> <li>• Two 11-gauge zinc-plated steel right-angle brackets that fasten together so that they rotate relative to each other</li> <li>• The MULTI-BEAM wiring base attaches to the upper bracket and slots are provided for vertical adjustment</li> <li>• The bottom bracket is a modified version of the SMB700. Assembly hardware and a cable gland are included</li> </ul>	
<p><b>SMB700M</b></p> <ul style="list-style-type: none"> <li>• Heavy-duty 1/4-inch (6mm) zinc-plated steel bracket</li> <li>• Allows the MULTI-BEAM to retrofit to installations of MLS8 or MLS9 sensors</li> <li>• Includes cable gland and lock washer</li> </ul>	
<p><b>SMB700P</b></p> <ul style="list-style-type: none"> <li>• Heavy duty 1/4-inch (6mm) zinc-plated steel bracket</li> <li>• Allows the MULTI-BEAM to retrofit to installations of 42RLU and 42RLP sensors</li> <li>• Includes cable gland and lock washer</li> </ul>	
<p><b>RF1-2NPS</b></p> <ul style="list-style-type: none"> <li>• Cable gland assembly for MULTI-BEAMS</li> <li>• Includes cord grips for 0.1 to 0.4-inch diameter cable</li> <li>• Bracket lock washer is also included</li> </ul>	
<p><b>MBC-4 and MBCC-412</b></p> <ul style="list-style-type: none"> <li>• <b>MBC-4</b> is a 4-pin male industrial-duty connector that threads into the base of all MULTI-BEAMS</li> <li>• <b>MBCC-412</b> is a 12-foot long (3.6 m) "SJT" type cable that is interchangeable with standard industry types of several different manufacturers</li> </ul>	

## Banner Engineering Corp Limited Warranty

Banner Engineering Corp. warrants its products to be free from defects in material and workmanship for one year following the date of shipment. Banner Engineering Corp. will repair or replace, free of charge, any product of its manufacture which, at the time it is returned to the factory, is found to have been defective during the warranty period. This warranty does not cover damage or liability for misuse, abuse, or the improper application or installation of the Banner product.

**THIS LIMITED WARRANTY IS EXCLUSIVE AND IN LIEU OF ALL OTHER WARRANTIES WHETHER EXPRESS OR IMPLIED (INCLUDING, WITHOUT LIMITATION, ANY WARRANTY OF MERCHANTABILITY OR FITNESS FOR A PARTICULAR PURPOSE), AND WHETHER ARISING UNDER COURSE OF PERFORMANCE, COURSE OF DEALING OR TRADE USAGE.**

This Warranty is exclusive and limited to repair or, at the discretion of Banner Engineering Corp., replacement. **IN NO EVENT SHALL BANNER ENGINEERING CORP. BE LIABLE TO BUYER OR ANY OTHER PERSON OR ENTITY FOR ANY EXTRA COSTS, EXPENSES, LOSSES, LOSS OF PROFITS, OR ANY INCIDENTAL, CONSEQUENTIAL OR SPECIAL DAMAGES RESULTING FROM ANY PRODUCT DEFECT OR FROM THE USE OR INABILITY TO USE THE PRODUCT, WHETHER ARISING IN CONTRACT OR WARRANTY, STATUTE, TORT, STRICT LIABILITY, NEGLIGENCE, OR OTHERWISE.**

Banner Engineering Corp. reserves the right to change, modify or improve the design of the product without assuming any obligations or liabilities relating to any product previously manufactured by Banner Engineering Corp. Any misuse, abuse, or improper application or installation of this product or use of the product for personal protection applications when the product is identified as not intended for such purposes will void the product warranty. Any modifications to this product without prior express approval by Banner Engineering Corp will void the product warranties. All specifications published in this document are subject to change; Banner reserves the right to modify product specifications or update documentation at any time. Specifications and product information in English supersede that which is provided in any other language. For the most recent version of any documentation, refer to: [www.bannerengineering.com](http://www.bannerengineering.com).

For patent information, see [www.bannerengineering.com/patents](http://www.bannerengineering.com/patents).

## Contact Us

Banner Engineering Corp. headquarters is located at: 9714 Tenth Avenue North | Minneapolis, MN 55441, USA | Phone: + 1 888 373 6767

For worldwide locations and local representatives, visit [www.bannerengineering.com](http://www.bannerengineering.com).

 [LinkedIn](#)

 [Twitter](#)

 [Facebook](#)

