

RF1A, RF1B



RF 1-phase solid state relay with LED and built-in transil



Benefits

- **Panel space savings.** 70% space savings with the RF compared to standard hockey puck SSRs.
- **Fast installation.** Quick connect terminals for fast and easy wiring.
- **User friendly.** LED for visual indication of control status.
- **Ready for use.** Pre-attached thermal interface to backplate.
- **Low equipment downtime.** Integrated protection against over-voltages across the RF output.
- **Long lifetime.** Wire bonding technology reduces thermal and mechanical stresses of the output chips.
- **Food & Beverage certification conformance.** 100,000 cycle endurance test according to UL508. Conformance to EN 60335-1 requirements.

Description

The **RF1** series provides a compact solid state switching solution suited for confined spaces. Long life time is ensured by the use of assembly technology that reduces stresses on the power semiconductors.

The **RF1** series is suitable for resistive loads. The zero switching type (**RF1A**), switches ON when the voltage crosses zero. The instant-ON type (**RF1B**), switches on when the control voltage is applied. Switch OFF occurs when current crosses zero.

Integrated transils provide protection against overvoltages. A green LED indicates presence of the control voltage. FASTON terminals enable fast installation. The **RF1** is provided with pre-attached thermal interface ready for mounting on chassis or heatsink.

Specifications are stated at 25°C unless otherwise noted.

Applications

Coffee machines, vending machines, food warmers, griddles, fryers, thermoforming machines, temperature control units, plastic dryers, plastic sealing machines, laboratory oven chambers, etc.

Main features

- Ratings up to 280 VAC, 25 AAC with typical DC control voltage of 5 VDC, 12 VDC, 24 VDC
- Integrated overvoltage protection on output
- Pre-attached thermal interface

Order code



RF1 23 25

Enter the code entering the corresponding option instead of

Code	Option	Description	Comments
R	-	Solid State Relay (RF) with LED and built-in transil	
F	-		
1	-	Number of poles	
<input type="checkbox"/>	A	Switching mode: zero cross (ZC)	
	B	Switching mode: instant on (IO)	
23	-	Rated voltage: 230 VAC (24-280 VAC) 50/60 Hz	
<input type="checkbox"/>	L	Control voltage: 5 VDC	
	M	Control voltage: 12 VDC	
	D	Control voltage: 24 VDC	
25	-	Rated current*	
<input type="checkbox"/>	X100	Bulk packaging of 100 pcs.	Optional

Selection guide

Rated voltage, Blocking voltage, Switching mode	Control voltage range	Maximum rated operational current*
		25 AAC
230 VAC, 600 Vp, ZC	4.25 - 9.0 VDC	RF1A23L25
	9.0 - 18.0 VDC	RF1A23M25
	18.0 - 28.8 VDC	RF1A23D25
230 VAC, 600 Vp, IO	4.5 - 9.0 VDC	RF1B23L25
	11.0 - 18.0 VDC	RF1B23M25
	18.0 - 28.8 VDC	RF1B23D25

Selection guide - Bulk packaging

Rated voltage, Blocking voltage, Switching mode	Control voltage range	Maximum rated operational current*
		25 AAC
230 VAC, 600 Vp, ZC	4.25 - 9.0 VDC	RF1A23L25X100
	9.0 - 18.0 VDC	RF1A23M25X100
	18.0 - 28.8 VDC	RF1A23D25X100

* Max. 25 AAC with suitable heatsink. Refer to Heatsink Selection tables.

Carlo Gavazzi compatible components

Description	Component code	Notes
Phase Change Thermal Pad	RFHT	Phase change thermal pad for RF1 packed x10 pcs. Dimensions: 19 mm x 17 mm
Heatsinks	RHS5050RFD	Heatsink with 3.5°C/W thermal resistance. Panel Mounting. Dimensions: 80 x 50 x 51 mm (Max. rating with mounted RF1 @ 40°C is 15 AAC)
	RHS38ARFD	Heatsink with 2.85°C/W thermal resistance. Thru wall or Panel Mounting. Dimensions: 46 x 76 x 33 mm (Max. rating with mounted RF1 @ 40°C is 16 AAC)

Further reading

Information	Where to find it
Online heatsink selector tool	https://gavazziautomation.com/nsc/HQ/EN/solid_state_relays

Structure

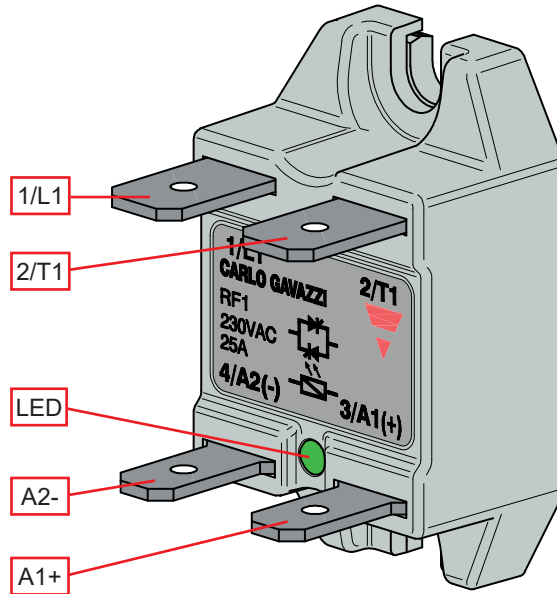

Element	Component	Function
1/L1	Power connection	Mains connection: Faston 6.35 x 0.8 mm
2/T1	Power connection	Load connection: Faston 6.35 x 0.8 mm
A1+	Control connection	Control signal
A2-	Control connection	Ground
LED	LED indicator	Green LED ON when control signal is applied

Features

General data

Material	PA66 (UL94 V0), RAL7035 850°C, 750°C/2s according to GWIT and GWFI requirements of EN 60335-1
Mounting	Panel
Touch Protection	IP20
Overvoltage Category	III, 4 kV (1.2/50 µs) rated impulse withstand voltage
Isolation	Input to Output: 3750 Vrms Input and Output to Case: 2500 Vrms
Weight	approx. 15 g approx. 210 g (box of 10 pcs.)

Dimensions

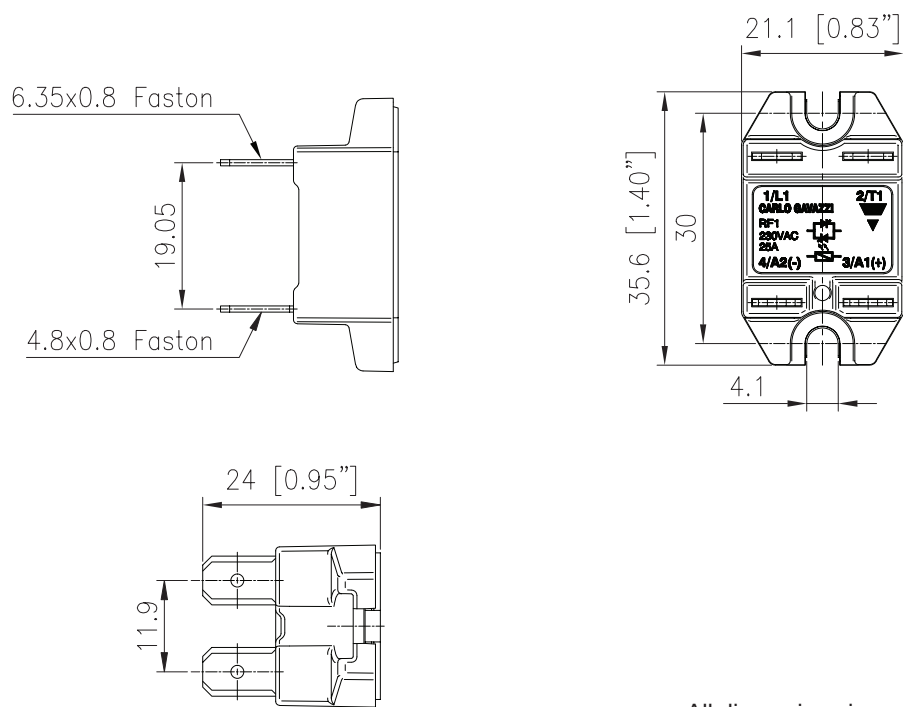

All dimensions in mm

Performance

▶ Outputs

	RF1A	RF1B
Operational voltage range, U _e	24-280 VAC	
Blocking voltage	600 V _p	
Switching mode	Zero cross	Instant on
Max. operational current: AC-51 rating*	25 AAC	
Operational frequency range	45 to 65 Hz	
Power factor	> 0.9 @ rated voltage	
Output protection	Integrated transil	
Leakage current @ rated voltage	< 3 mAAC	
Minimum operational current	150 mA	
Rep. overload current - UL508: T=40°C, t _{ON} =1s, t _{OFF} =9s, 50 cycles	40 AAC	
Non-repetitive surge current (t=10ms)	325 A _p	
I ² t for fusing (t=10ms), minimum	525 A ² s	
LED indication - CONTROL	Continuously ON Green LED, when control input is applied	
Critical dV/dt (@T _j init = 40°C)	1000 V/μs	
Endurance testing acc. to UL508	100,000 cycles	

* Max. 25 AAC with suitable heatsink. Refer to Heatsink Selection tables.

Inputs

	RF1..L	RF1..M	RF1..D
Control voltage range (Uc)			
RF1A	4.25 - 9.0 VDC	9.0 - 18.0 VDC	18.0 - 28.8 VDC
RF1B	4.5 - 9.0 VDC	11.0 - 18.0 VDC	18.0 - 28.8 VDC
Pick-up voltage			
RF1A	4.25 VDC	9.0 VDC	18.0 VDC
RF1B	4.5 VDC	11.0 VDC	18.0 VDC
Drop-out voltage		1.0 VDC	
Maximum reverse voltage	9.0 VDC	18.0 VDC	28.8 VDC
Maximum response time pick-up		1/2 cycle	
RF1A		350 µs	
RF1B			
Response time drop-out		1/2 cycle	
RF1A		1/2 cycle	
RF1B		1/2 cycle	
Input current @ 40°C	See diagrams below		

Input current vs. input voltage

RF1..L

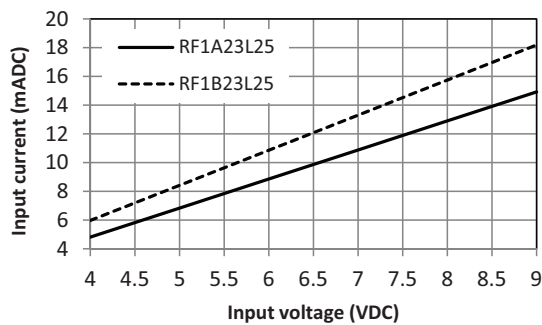

RF1..M

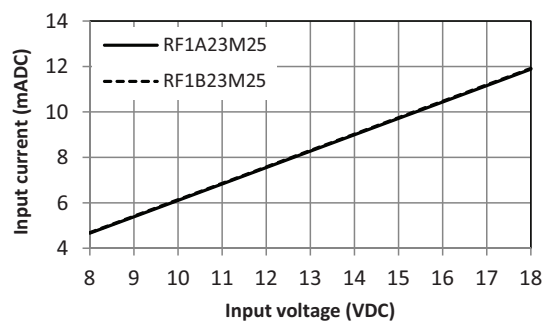

RF1..D

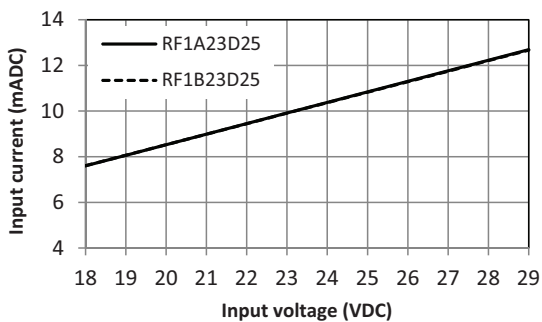

Output power dissipation (P_D)

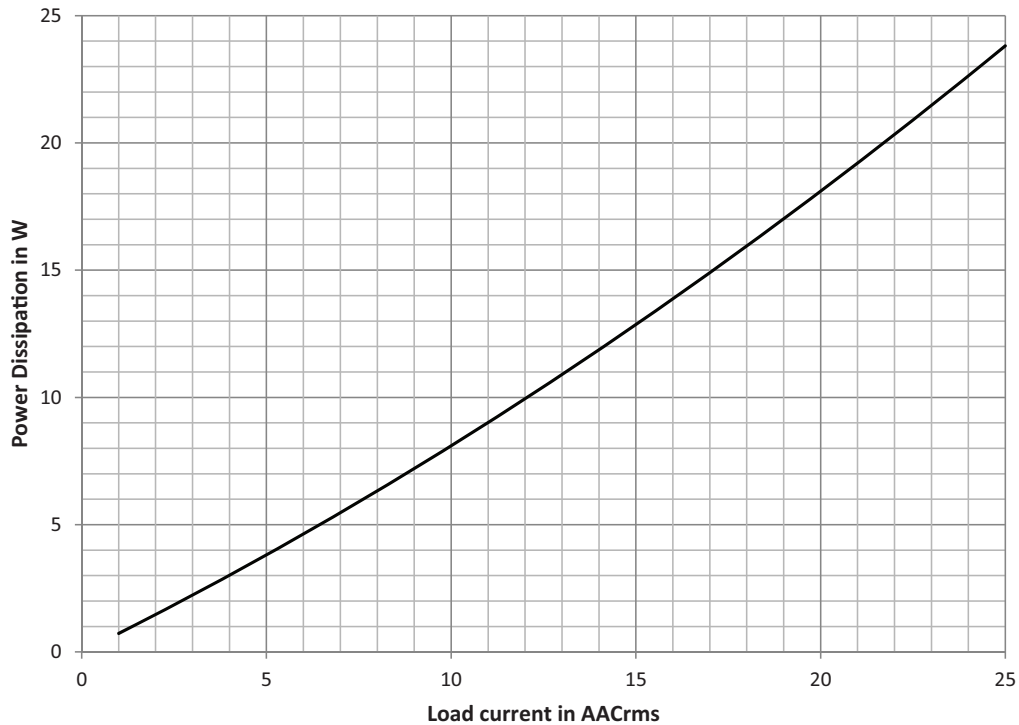

Heatsink selection

Thermal resistance [$^{\circ}\text{C}/\text{W}$]

Load current AC-51 [A]	Surrounding ambient temperature [$^{\circ}\text{C}$]						
	20	30	40	50	60	70	80
25	2.5	1.9	1.3	0.8	0.3	---	---
22.5	3.2	2.5	1.8	1.1	0.5	---	---
20	4.1	3.2	2.4	1.6	0.9	0.2	---
17.5	5.5	4.3	3.2	2.3	1.4	0.6	---
15	7.5	5.9	4.4	3.2	2.1	1.0	0.1
12.5	10	8.4	6.4	4.6	3.1	1.7	0.5
10	16	12	9.3	6.8	4.7	2.8	1.2
7.5	---	---	15	10	7.1	4.3	2.0
5	---	---	---	---	13	7.5	3.4
2.5	---	---	---	---	---	---	8.5

Note: These thermal resistance values are only applicable to the RF1 using the pre-attached thermal interface.





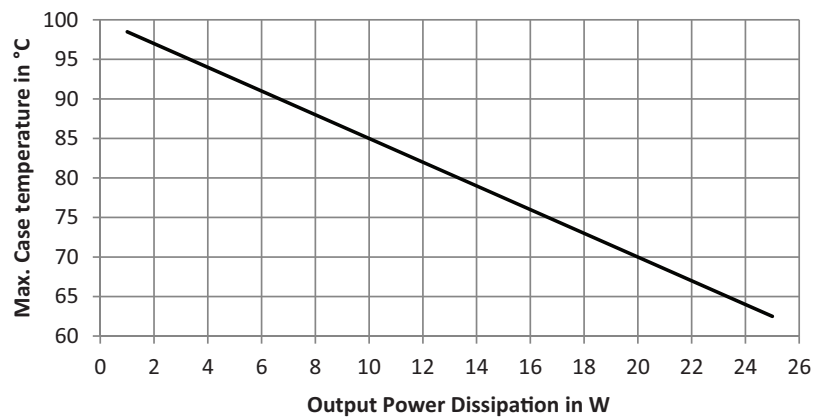

Thermal data

Max. junction temperature, T_j	100 °C (212 °F)
Junction to case thermal resistance (including the pre-attached thermal interface), R_{thjc}	1.5 °C/W
Max. case temperature, T_c	$T_j - (P_D \times R_{thjc})$ See chart below



Duty cycle is considered to be 100%

Compatibility and conformance

Approvals	      
Standards compliance	<p>LVD: EN 60947-4-3 EMCD: EN 60947-4-3 UR: UL508, E80573, NRNT2 cUR: CSA 22.2 No.14-13, E80573, NRNT8 CSA: CSA 22.2 No.14-13, 204075 VDE: DIN EN 60947-4-3 (VDE 0660-109), DIN EN 60335-1 (VDE 0700-1)</p>

Electromagnetic compatibility (EMC) - Immunity	
Electrostatic discharge (ESD)	EN/IEC 61000-4-2 8 kV air discharge, 4 kV contact (PC2)
Radiated radio frequency	EN/IEC 61000-4-3 10 V/m, from 80 MHz to 1 GHz (PC1) 10 V/m, from 1.4 to 2 GHz (PC1) 3 V/m, from 2 to 2.7 GHz (PC1)
Electrical fast transient (burst)	EN/IEC 61000-4-4 Output: 2 kV, 5 kHz (PC2) Input: 1 kV, 5 kHz (PC2)
Conducted radio frequency	EN/IEC 61000-4-6 10V/m, from 0.15 to 80 MHz (PC1)
Electrical surge	EN/IEC 61000-4-5 Output, line to line: 1 kV (PC1) Output, line to earth: 2 kV (PC1) Input, line to line: 500 V (PC1) Input, line to earth: 500 V (PC1)
Voltage dips	EN/IEC 61000-4-11 0% for 0.5, 1 cycle (PC2) 40% for 10 cycles (PC2) 70% for 250 cycles (PC2)
Voltage interruptions	EN/IEC 61000-4-11 0% for 5000 ms (PC2)

Electromagnetic compatibility (EMC) - Emissions	
Radio interference field emission (radiated)	EN/IEC 55011 Class B: from 30 to 1000 MHz
Radio interference voltage emissions (conducted)	EN/IEC 55011 Class A: from 0.15 to 30 MHz (for currents >15 AAC a filter 100 nF / 275 VAC / X1 is needed for compliance)

Filter connection diagram

1 Phase

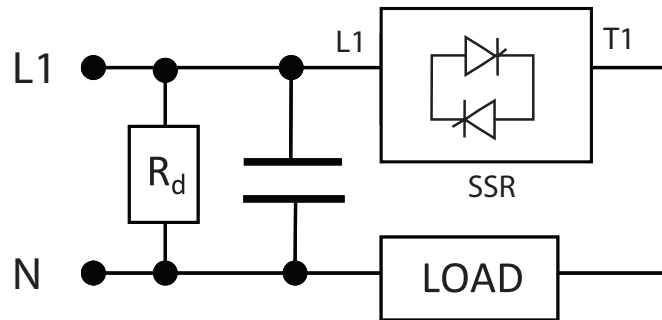

$$R_d = 1M\Omega, 0.5W$$

Note:

- Control input lines must be installed together to maintain products' susceptibility to Radio Frequency interference.
- Use of AC solid state relays may, according to the application and the load current, cause conducted radio interferences. Use of mains filters may be necessary for cases where the user must meet E.M.C requirements. The capacitor values given inside the filtering specification tables should be taken only as indications, the filter attenuation will depend on the final application.
- Performance Criteria 1 (PC1): No degradation of performance or loss of function is allowed when the product is operated as intended.
- Performance Criteria 2 (PC2): During the test, degradation of performance or partial loss of function is allowed. However when the test is complete the product should return operating as intended by itself.
- Performance Criteria 3 (PC3): Temporary loss of function is allowed, provided the function can be restored by manual operation of the controls.

Environmental specifications

Operating temperature	-30°C to 80°C (-22 to 176°F)
Storage temperature	-40°C to 100°C (-40 to 212°F)
Relative humidity	95% non-condensing @ 40°C
Pollution degree	2
Installation altitude	0-1000 m. Above 1000 m derate linearly by 1% of FLC per 100 m up to a maximum of 2000 m
Vibration resistance	2g / axis (2-100Hz, IEC60068-2-6, EN50155, EN61373)
Impact resistance	15/11 g/ms (EN50155, EN61373)
EU RoHS compliant	Yes
China RoHS	

The declaration in this section is prepared in compliance with People's Republic of China Electronic Industry Standard SJ/T11364-2014: Marking for the Restricted Use of Hazardous Substances in Electronic and Electrical Products.

Part Name	Toxic or Harardous Substances and Elements					
	Lead (Pb)	Mercury (Hg)	Cadmium (Cd)	Hexavalent Chromium (Cr(VI))	Polybrominated biphenyls (PBB)	Polybrominated diphenyl ethers (PBDE)
Power Unit Assembly	x	o	o	o	o	o

O: Indicates that said hazardous substance contained in homogeneous materials for this part are below the limit requirement of GB/T 26572.

X: Indicates that said hazardous substance contained in one of the homogeneous materials used for this part is above the limit requirement of GB/T 26572.

这份申明根据中华人民共和国电子工业标准 SJ/T11364-2014：标注在电子电气产品中限定使用的有害物质

零件名称	有毒或有害物质与元素					
	铅 (Pb)	汞 (Hg)	镉 (Cd)	六价铬 (Cr(VI))	多溴化联苯 (PBB)	多溴联苯醚 (PBDE)
功率单元	x	o	o	o	o	o

O:此零件所有材料中含有的该有害物低于GB/T 26572的限定。

X: 此零件某种材料中含有的该有害物高于GB/T 26572的限定。

Short circuit protection

Protection Co-ordination Type 2

Part No.	Prospective short circuit current [kArms]	Mersen*	Siba
RF1..25	10	690 VAC, 25A gR 10x38 mm, FR10GR69V25	600 VAC, 25A gRL 10x38 mm, 60 034 34.25

* Formerly Ferraz Shawmut

Connection diagram

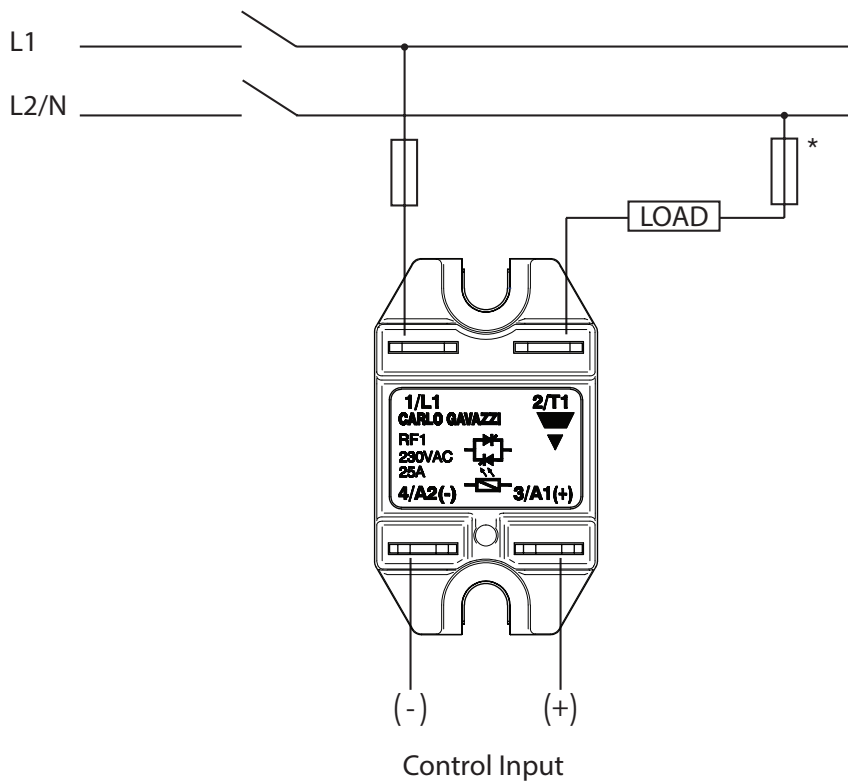

*depends on system requirements

Functional diagram

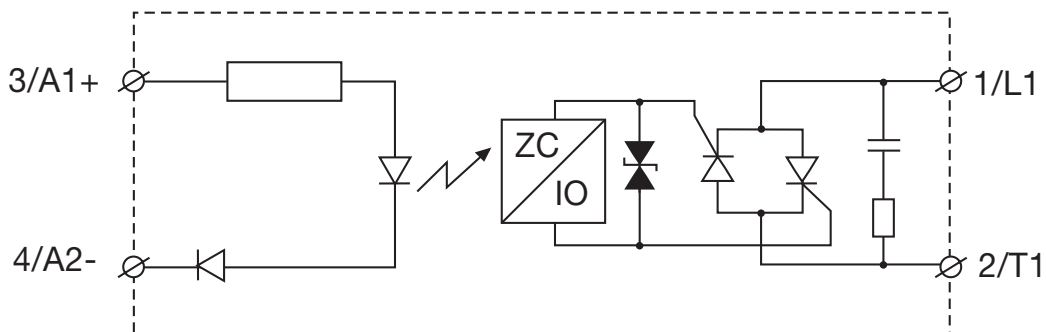

Installation

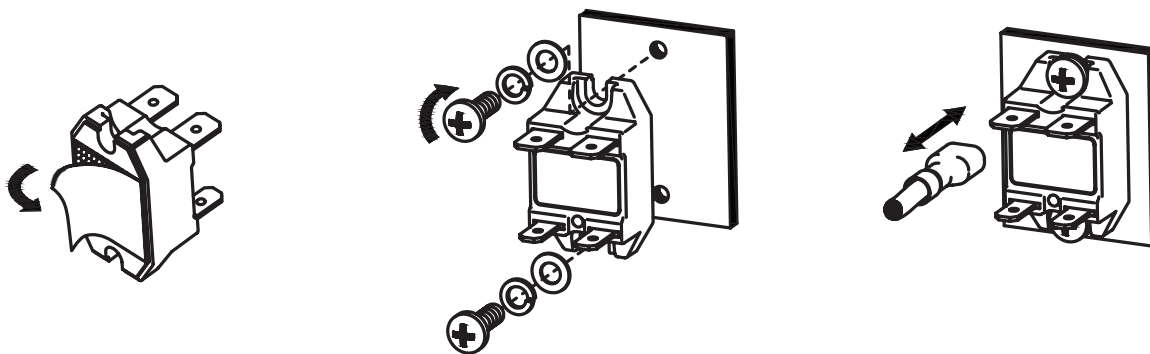

1. Peel off liner before mounting on heatsink.

2. Tighten screws alternately to max. 1.0Nm.

3. Insert / remove FASTON receptacle only with RF1 tightened to a surface.

Connection specifications

Power connection	
Terminal	1/L1, 2/T1
Connection type	Faston 6.35 x 0.8 mm
Conductors	Use 75°C copper (Cu) conductors
Fastons pull-out force*	130 N

Control connection	
Terminal	3/A1+, 4/A2-
Connection type	Faston 4.8 x 0.8 mm
Fastons pull-out force*	130 N

SSR mounting	
Connection type	M4 screws
Mounting torque	1.0 Nm (8.85 lb-in)

*refer to Installation section

Packaging

RF1...



- 10 pcs. per box
- Weight per box, approx. 210 g

RF1...X100



- 100 pcs. per box (2 layers of 50 pcs.)
- Weight per box, approx. 1681 g



COPYRIGHT ©2020
Content subject to change. Download the PDF: <https://gavazziautomation.com>