

Resistive Touch Display 7" Parallel

Datasheet





LOGIC
TECHNOLOGIES

PRODUCT SPECIFICATION

DESCRIPTION

TFT Module – 7.0” WVGA
800 x (RGB) x 480
High brightness
with Resistive Touch

PART NUMBER

LT161010-2NHR

VERSION

1.7

ROHS COMPLIANT

Table of Contents

- GENERAL INFORMATION
- MECHANICAL DIMENSIONS
- ABSOLUTE MAXIMUM RATINGS
- ELECTRICAL CHARACTERISTICS
- BACKLIGHT CHARACTERISTICS
- ELECTRO-OPTICAL CHARACTERISTICS
- INTERFACE DESCRIPTION
- BLOCK DIAGRAM
- TIMING CHARACTERISTICS
- TIMING CHART & DATA
- RESISTIVE TOUCH CHARACTER
- PACKAGE DRAWING
- RELIABILITY TESTING
- INSPECTION CRITERIA
- INSPECTION STANDARD
- PRECAUTIONS FOR USING LCD MODULES

- GENERAL INFORMATION

Item	Contents	Unit
LCD Type	TFT Transmissive, anti-glare	/
Technology	a-Si TFT	-
Viewing Direction	12:00	O'clock
Viewing Angle (Gray Scale Inversion Direction)	6:00	O'clock
Module dimensions (W x H x T)	164.9 x 100.0 x 13.0(Max)	mm
Active area (W x H)	154.08 x 85.92	mm
Number of pixels	800 x 3 (RGB) x 480	/
Pixel pitch (W x H)	0.1926 x 0.179	mm ²
Colours	16.7M	/
Contrast ratio	500 (typical)	/
Backlight	LED (27; 3x serial, 9 x parallel)	/
Backlight Brightness	450	cd/m ²
Interface	RGB 18bit + TCON	/
Touch solution	With Resistive Touch	/
Touch driver	N/A	/
Touch Interface	N/A	/
Operating temperature	-20 to +70	°C
Storage temperature	-30 to +80	°C

MECHANICAL DIMENSIONS

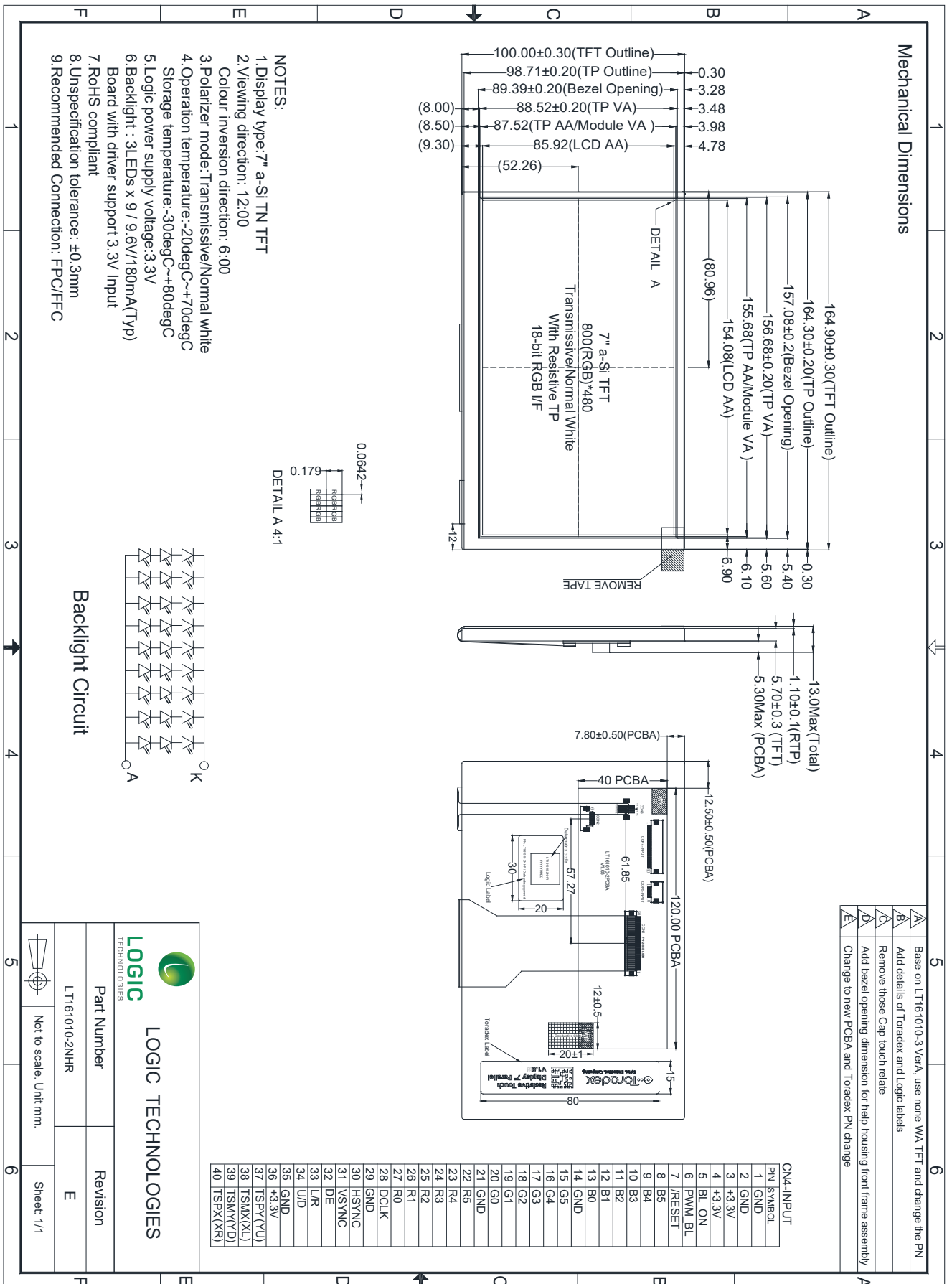

- ABSOLUTE MAXIMUM RATING

Parameter	Symbol	Min.	Max.	Unit	Note
Power Voltage	VDD	- 0.5	5.0	V	---
Backlight LED Forward Current	I _F	---	25	mA	One LED
Operating Temperature	T _{OPR}	- 20	70	°C	---
Storage temperature	T _{ST}	- 30	80	°C	---

- ELECTRICAL CHARACTERISTICS (Ta = 25°C)

Parameter	Symbol	Min	Typ.	Max	Unit	Remark
Digital Supply Voltage	VDD	3.0	3.3	3.6	V	---
Input Signal Voltage	V _{IL}	0	---	0.3xDVDD	V	R0-R7, G0-G7, B0-B7, DE, DCLK, HSD, VSD, RESET
	V _{IH}	0.7xDVDD D	---	DVDD	V	
Current of supply voltage	IVDD		850	1200	mA	
Power Consumption	P		2.75	3.87	W	All pixels on and black

- BACKLIGHT UNIT CHARACTERISTICS

Item	Symbol	Min.	Typ.	Max.	Unit	Condition
Driver Input Voltage	VDD	---	3.3	3.6	V	
Current of driver IC	I _{vdd}	---	700	1000		
PWM Frequency	PWM	100	150	200	Hz	
Forward Current	I _F	---	180	200	mA	Notes
Forward Current Voltage	V _F	---	9.9	10.8	V	Notes
LED Lifetime	---	30k	---	---	Hrs	Notes
Power Consumption	P _{BL}	---	2.31	3.6	W	Notes

NOTES:

Backlight drive conditions : constant current driving method.

- The LED driving condition is defined for each LED module (3 LED Serial, 9 LED Parallel).
- The LED driving condition is defined for total backlight consumption.
- Forward Voltage adjustment depends on the Forward Current setting.
- One LED : max I_F = 25mA, V_F = 3.3V
- The LED lifetime is estimated data at 25degC operating.

- I_F defined for whole backlight without driver.
- If the LEDs are driven by high current, high ambient temperature & humidity condition the lifetime of the LEDs will be reduced.
- Operating life means brightness reduces to 50% of initial brightness.
- Backlight diagram.

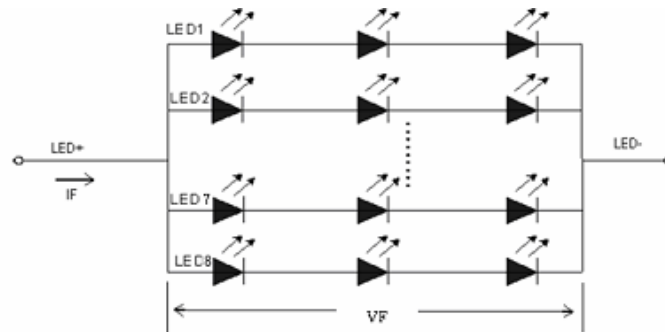

ELECTRO-OPTICAL CHARACTERISTICS

Item	Symbol	Condition	Min.	Typ.	Max.	Unit	Refer	Note	
Response Time	T_{ON}	25°C	---	10	15	Ms	Fig 1	1	
	T_{OFF}		---	15	20				
Contrast ratio	Cr	$\theta = 0^\circ$	400	500	---	---	Fig 2	1	
Uniformity	U	---	---	75	---	%	Fig 2	3	
Surface Luminance	L_v	---	400	450	---	cd/m ²	Fig 2	2	
Viewing Angle ratio	θ	$\varnothing = 90^\circ$	45	55	---	---	Fig 3	6	
		$\varnothing = 270^\circ$	50	60	---				
		$\varnothing = 0^\circ$	50	60	---				
		$\varnothing = 180^\circ$	50	60	---				
CIE (x,y) chromaticity	Red	x	Backlight On	0.559	0.609	0.659	---	Fig 2.	5
		y		0.305	0.355	0.405			
	Green	x		0.277	0.315	0.364			
		y		0.505	0.555	0.605			
	Blue	x		0.089	0.136	0.189			
		y		0.089	0.139	0.189			
	White	x		0.254	0.304	0.354			
		y		0.294	0.344	0.394			

Optical performance should be evaluated at $T_a=25^\circ\text{C}$.

Note

1. Contrast ratio (CR) is defined mathematically in Figure 2.

$$\text{Contrast Ratio} = \frac{\text{Average Surface Luminance with all white pixels (P1, P2, P3, P4, P5)}}{\text{Average Surface Luminance with all black pixels (P1, P2, P3, P4, P5)}}$$

Note 2. Surface luminance is the LCD surface from the surface with all pixels displaying white. For more information see figure 2.

$$L_v = \text{Average Surface Luminance with all white pixels (P1, P2, P3, P4, P5...)}$$

Note 3. Uniformity of surface luminance, White, is defined mathematically in figure 2.

$$\text{White} = \frac{\text{Minimum Surface Luminance with all white pixels (P1, P2, P3, P4, P5)}}{\text{Maximum Surface Luminance with all white pixels (P1, P2, P3, P4, P5)}}$$

Note 4. Response time is the time required for the display to transition from white to black (rise time T_r) and from black to white (decay or fall time, T_f). The industry standard test equipment used is the Autronic-Melcher's Conoscope.

Note 5. CIE (x,y) chromaticity. The x,y value is determined by measuring luminance at each test position 1 through 5, then calculating the average value.

Note 6. The Viewing angle is the angle at which the contrast ratio is greater than 2. For a TFT module, the contrast ratio is greater than 10. The angles are determined for the horizontal or 'x' axis and the vertical or 'y' axis with respect to the 'z' axis, being the LCD surface reference. Also see figure 3.

Note 7. For viewing angle and response time testing, the testing data is based on Autronic-Melcher's BM-7A. For the contrast ratio, surface luminance, luminance uniformity and chromaticity (CIE), the test data is based on the industry's standard SR-3A photo detector.

Note 8. For TFT modules, grey scale reversing occurs in the direction of the panel viewing angle.

Figure 1. Definition of response time

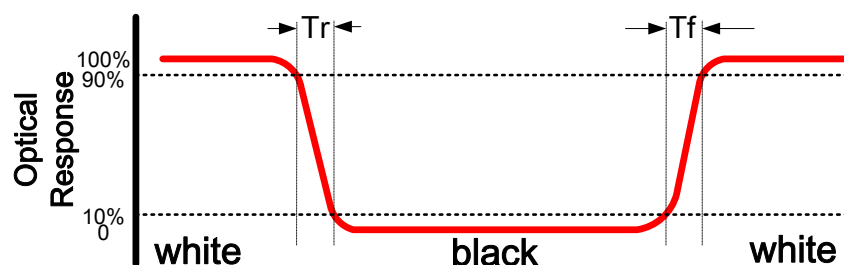

Figure 2. Measuring contrast ratio, surface luminance, luminance uniformity and CIE (chromaticity.)

A : 5mm, B : 5mm, H, V : Active area, Light spot size $q = 7\text{mm}$, 500mm distance from the LCD surface to the detector lens.

Measurement instrument is Topcon's luminance meter BM-5.

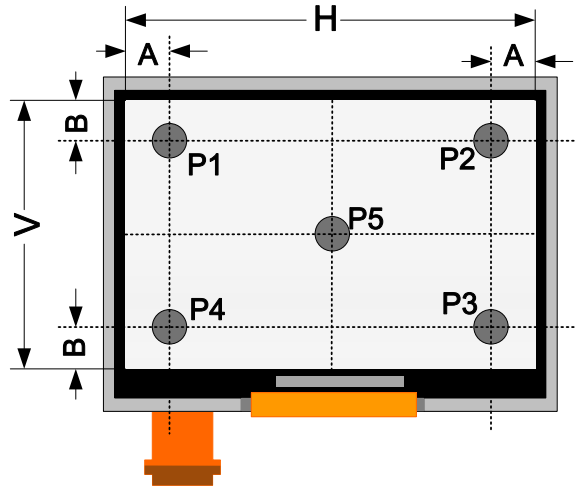
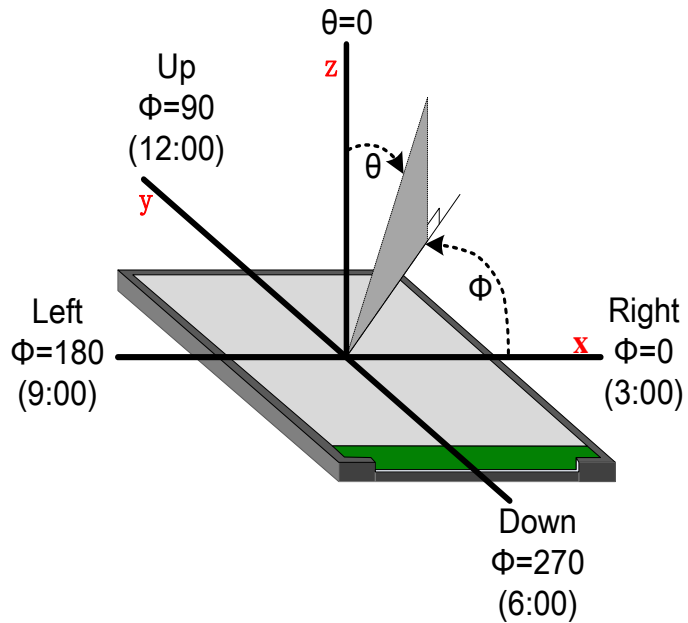

Figure 3. Definition of viewing angle



- INTERFACE DESCRIPTION

CN4 (40pins connector for display and backlight)

Pin	Symbol	I/O	Description	Note
1	GND	P	Ground	
2	GND	P	Ground	
3	+3.3V	P	3.3V supply power input	
4	+3.3V	P	3.3V supply power input	
5	BL_ON	I	Backlight on/off control pin. H: On ; L: Off	
6	PWM_BL	I	PWM signal to control backlight diming. 100~200Hz; 0% duty-cycle: max brightness, 100% duty-cycle: min brightness	
7	/RESET	I	TFT display system reset	
8	B5	I	Blue data signal (MSB)	
9	B4	I	Blue data signal	
10	B3	I	Blue data signal	
11	B2	I	Blue data signal	
12	B1	I	Blue data signal	
13	B0	I	Blue data signal (LSB)	
14	GND	P	Ground	
15	G5	I	Green data signal (MSB)	
16	G4	I	Green data signal	
17	G3	I	Green data signal	
18	G2	I	Green data signal	
19	G1	I	Green data signal	
20	G0	I	Green data signal (LSB)	
21	GND	P	Ground	
22	R5	I	Red data signal (MSB)	
23	R4	I	Red data signal	
24	R3	I	Red data signal	
25	R2	I	Red data signal	
26	R1	I	Red data signal	
27	R0	I	Red data signal (LSB)	
28	DCLK	I	Display clock signal	
29	GND	P	Ground	

30	HSYNC	I	Horizontal synchronizing signal	
31	VSYNC	I	Vertical synchronizing signal	
32	DE	I	Input data enable control	
33	NC_L/R	I	Not connection, as with L/R jumper on board	
34	NC_U/D	I	Not connection, as with U/D jumper on board	
35	GND	P	Ground	
36	3.3V	P	3.3V supply power input	
37	TSPY(YU)	--	Resistive touch terminal	
38	TSMX(XL)	--	Resistive touch terminal	
39	TSMY(YD)	--	Resistive touch terminal	
40	TSPX(XR)	--	Resistive touch terminal	

I -Input only; O -Output only; I/O -Input /output; P -Power or Ground.

Suggested connector for this connector is 0.5pitch 40pins FFC or FPC

Note 1: Data shall be latched at the falling edge of DCLK.

Note 2: Global reset pin, low active. Suggest it connect with an RC reset circuit for stability. Normally pull high.

Block Diagram

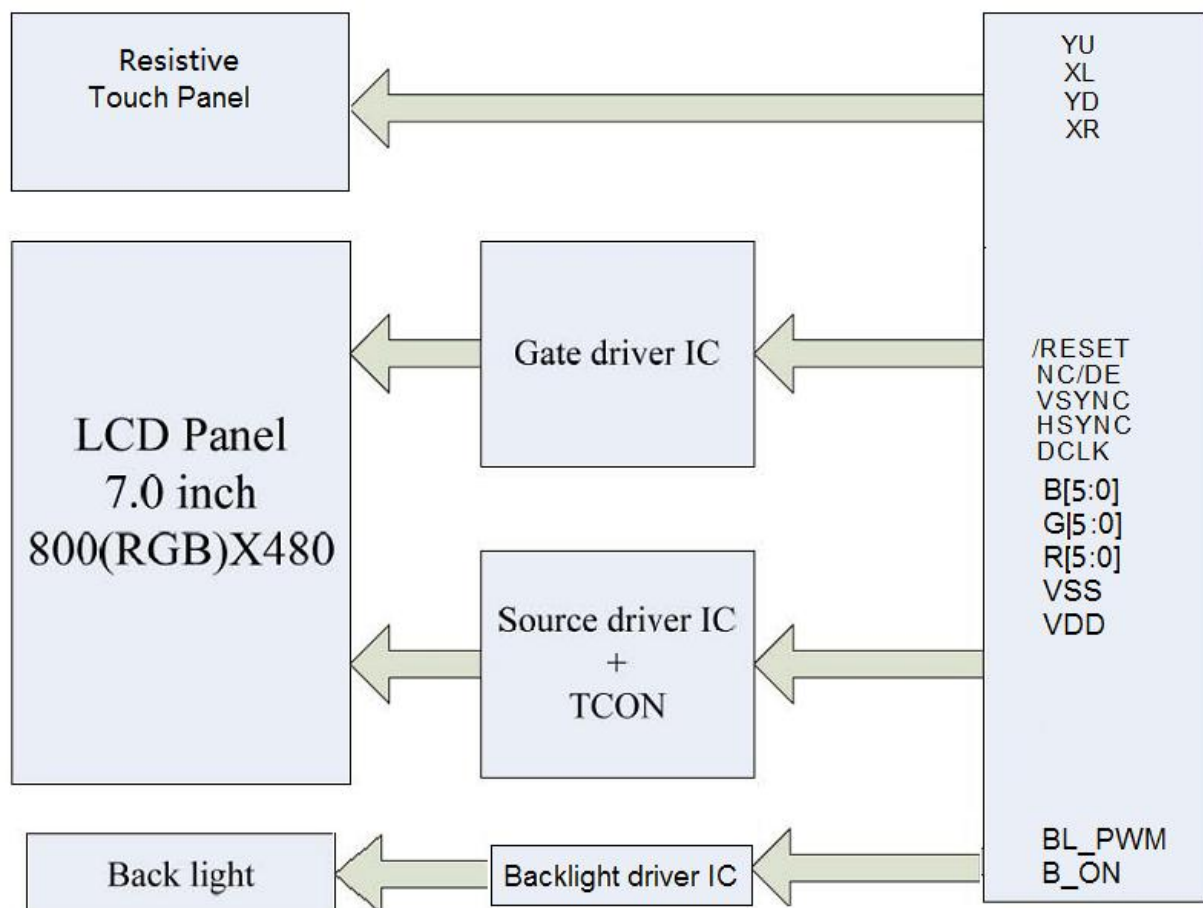

• RESET TIMING CHARACTERISTICS

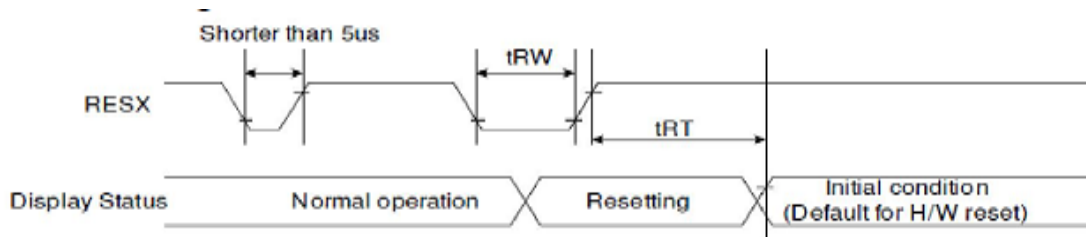

Signal	Symbol	Parameter	Min	Max	Unit
RESX	tRW	Reset pulse duration	10	5	uS
	tRT	Reset cancel		(note 1,5) 120	mS
				(note 1,8,7)	mS

• RGB TIMING CHARACTERISTICS

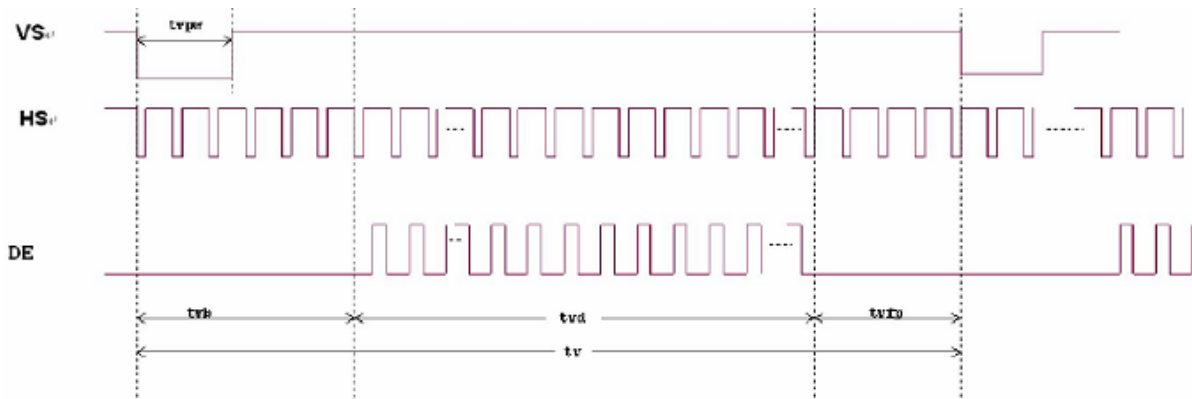

TCON (Embedded In Source IC) Input Timing (DCLK, HS, VS, DE)

VCC=3.3V, GND=0V, Ta=25°C

Parameter	Symbol	Min	Typ	Max	Unit	Remark
DCLK	F _{clk}	26.4	33.3	46.8	MHZ	
	t _{clk}	21.4	30	37.8	ns	
HS	t _h	862	1056	1200	t _{clk}	
	t _{hd}		800		t _{clk}	
	t _{hpb}	1		40	t _{clk}	
	t _{hb}	46	46	46	t _{clk}	
	t _{hfp}	16	210	354	t _{clk}	
VS	t _v	510	525	650	t _h	
	t _{vd}		480		t _h	
	t _{vpw}	1		20	t _h	
	t _{vb}	23	23	23	t _h	
	t _{vfp}	7	22	147	t _h	

Note 1: DE timing refer to HS, VS input timing.

• AC TIMING CHARACTERISTICS

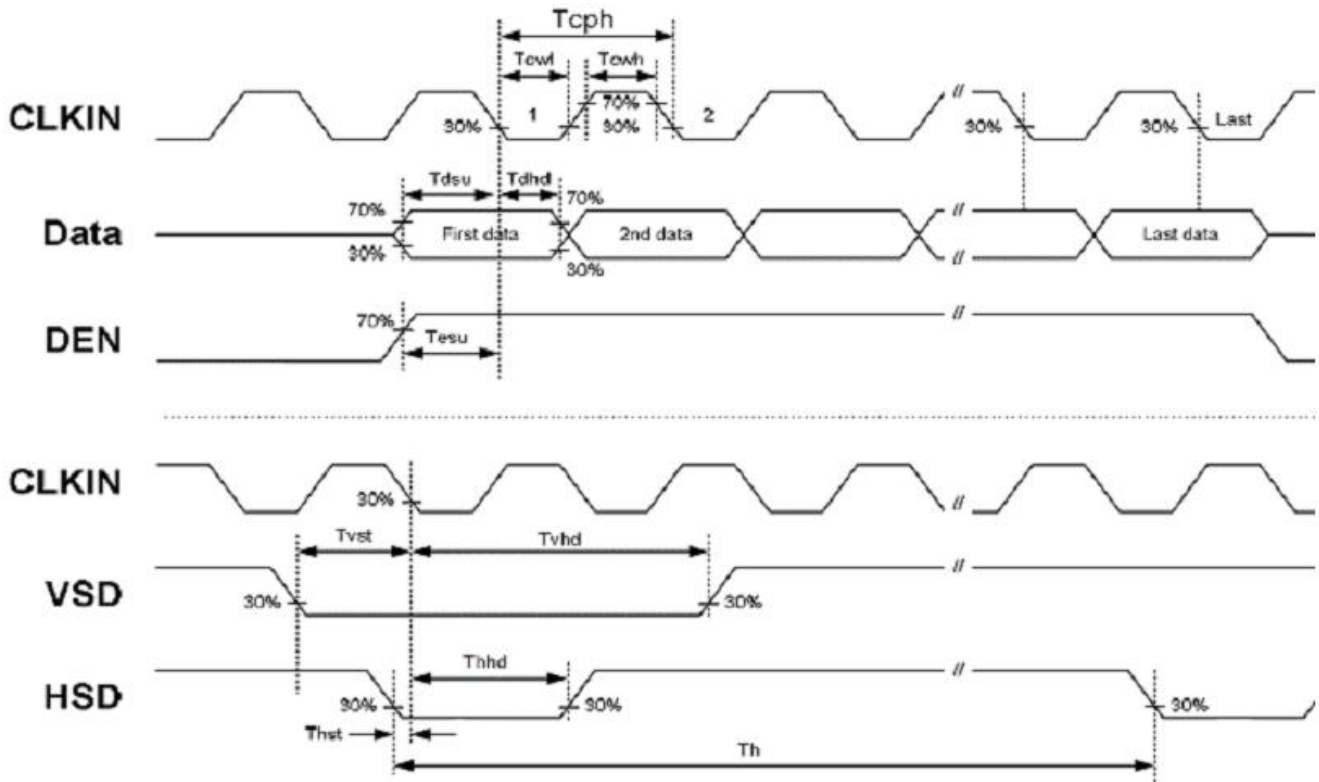

Parameter	Symbol	Min	Typ	Max	Unit	Note
DCLK Frequency	Fclk	---	33.3	46.8	MHz	
DCLK Cycle Time	Tcph	20			ns	
DCLK Pulse Width	Tcw	40	50	60	Tcph	
VSD Setup Time	Tvst	8	---	---	ns	
VSD Hold Time	Tvhd	8	---	---	ns	
HSD Setup Time	Thst	8	---	---	ns	
HSD Hold Time	Thhd	8	---	---	ns	
Data Setup Time	Tdsu	8	---	---	ns	Data to DCLK
Data Hold Time	Tdhd	8	---	---	ns	Data to DCLK
DE Setup Time	Tesu	8	---	---	ns	
DE Hold Time	Tehd	8	---	---	ns	

• **TOUCH PANEL CHARACTERISTICS**

Electrical Characteristic

Item	Min.	Typ.	Max.	Unit	Remark	
Linearity	-1.5%	---	1.5%	---	Each axis: X and Y	
Operating Voltage	---	5.0	10.0	V	DC	
Resistance	X axis:	480	---	1100	Ω	Film
	Y axis:	120	---	450	Ω	Glass
Chattering Time	---	---	10.0	ms		
Insulation Resistance	20	---	---	MΩ	@DC ≤10V	

Notes:

(a) Touch Panel Test Condition:

Typical is 23°C, 65%RH and 1013hPa. General can test the touch panel under 23°C±5°C, 45%-85%RH and 860hPa-1060hPa.

(b) Linearity Definition

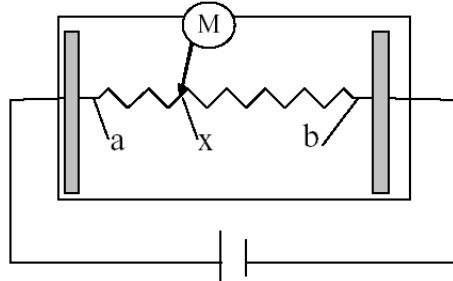

Va: maximum voltage in the active area of touch panel

Vb: minimum voltage in the active area of touch panel

X: random measuring point

Vxm: actual voltage of Lx point

Vxi: theoretical voltage of Lx point

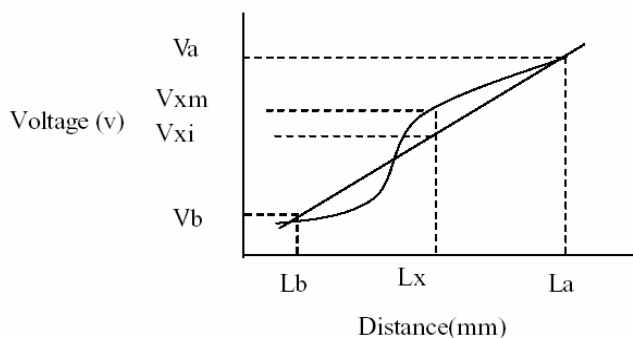

$$\text{Linearity} = \left[\frac{|Vxi - Vxm|}{(Va - Vb)} \right] * 100\%$$

(c) Test area:

As follows and operation force is 180gf (single layer ITO Film), placental stylus is R0.8mm.

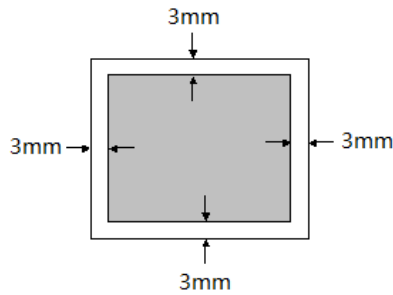

(d) Chattering measure definition (Condition: @ 3.0V, Frequency: 5HZ).

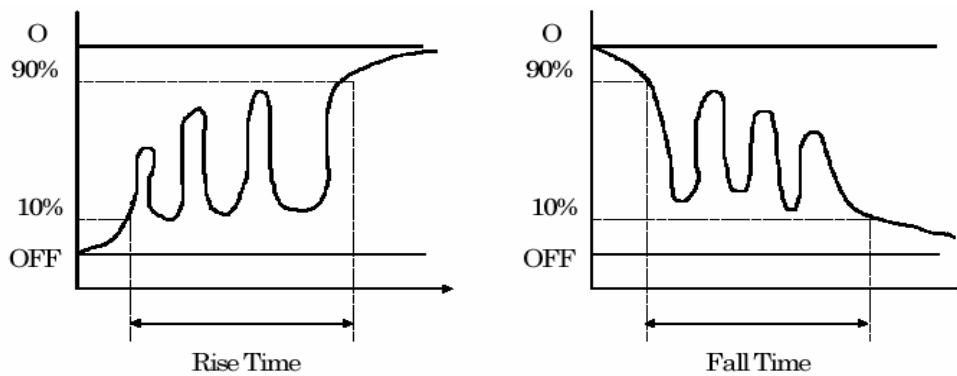

Mechanical Characteristic

Description	Specification	Remark
Activation force	100gf Max.	Test with Silicon pen. Hardness: SHORE A 30° Neb dirmeterϕ 12mm. Surface radian R12.5 mm
	100gf Max.	Test with Polyacetal pen. Neb dirmeterϕ 3.0 mm. Surface radian R0.8 mm
FPC Peeling Force	Min. : 600gf	Peeling upward by 90° , 3minutes
	Min. : 500gf	Peeling upward by 180° , 10minutes
Flexible pattern bending resistance	10 times at least.	Bending radius: R1.0 mm Bending times: 10 times

Notes:

(a) Activation force test condition:

1. Input DC 5V on X direction , Drop off Polyacetal Stylus(R0.8),until output voltage stabilize ,then get the activation force ;

2. R8 Silicon rubber for finger Activation force test ;

3. Test point : 9 points.

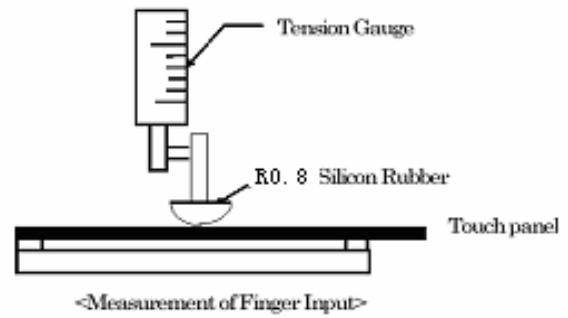
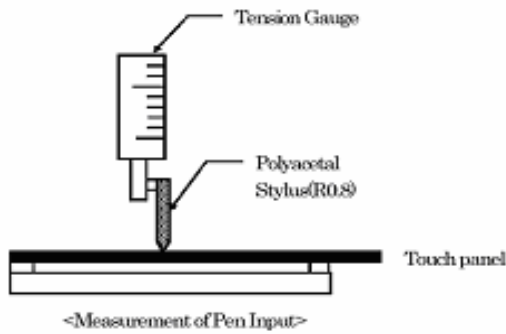

(b) Peeling upward by 90°, 500gf 3minutes

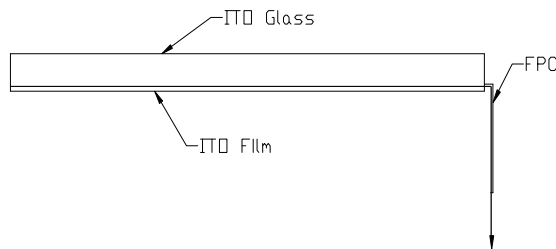

Peeling upward by 180°, 500gf 10minutes

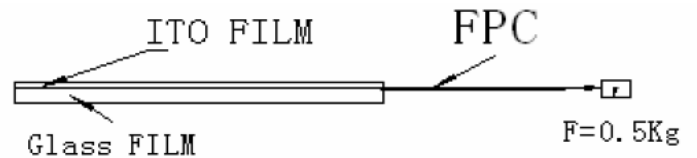

Optical Characteristic

Description	Specification	Remark
Transparency	75% (Min.)	JIS K-7105
Haze	7 % (Max)	JIS K-7105
Newton's Ring	N/A	40W natural color , 30cm distance at least,

Notes:

(a) Newton's Ring test condition:

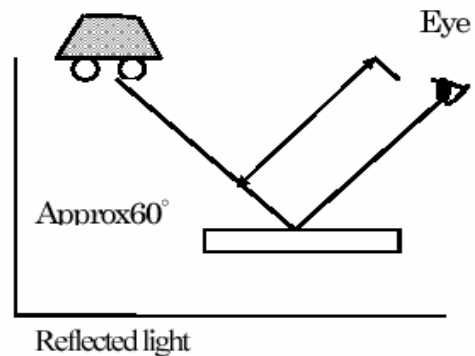
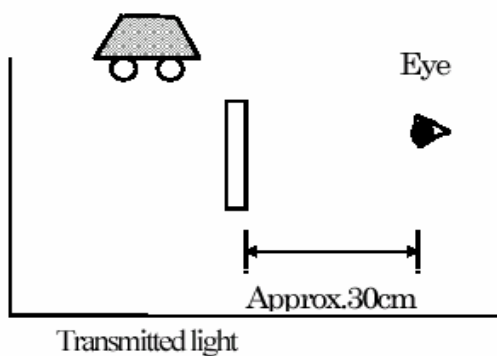

Durability Test

Under defined terms and condition test, product must be still satisfactory to electrical and mechanical characteristic.

Description	Specification	Remark
Pen sliding Durability	$\geq 50,000$ cycles	End shape: R0.8mm (Stylus) Load force: 250 gf Writing speed: 60 mm/sec Material of Pen: Polyacetal resin Sliding length: 30 mm Sliding location: Screen center Considered a one-way, return will be counted twice.
Hitting Durability	≥ 1 Million times	End shape: R0.8mm Hardness: 60° Load force: 250 gf Frequency: 2 Hz Material of Pen: Silicon rubber

Structure and Area Definition, RTP housing design guide

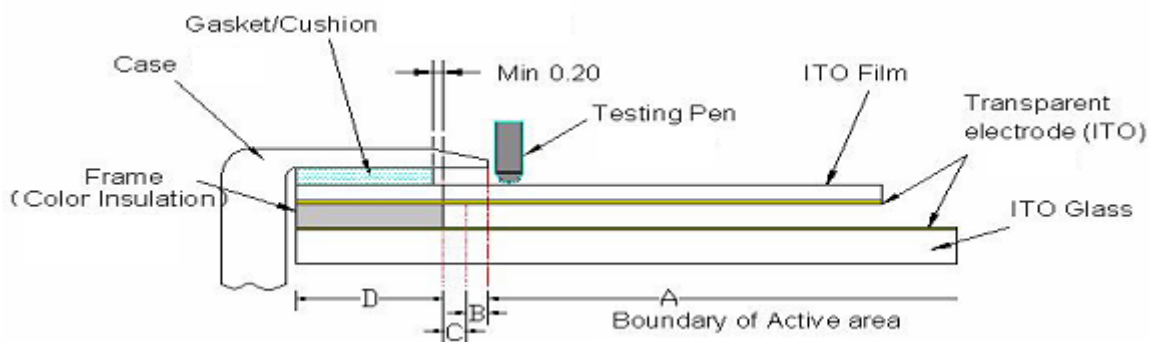

Area-(A): Active area. The area guarantees a touch panel operation with the following characteristics when pressed.

(I) Operation Force (II) Electrical (III) Pen Hitting Durability (IV) Pen Sliding Durability

Area-(B): Operation Non-Guaranteed Area. The area does not guarantee the operation of touch panel and its function. When this area is pressed, touch panel shows degradation of its performance and durability such as a pen sliding durability becomes about one-tenth compared with the active area (Area- (A) as guaranteed area) and its operation force requires about double. This area is defined about 0.5 mm outside the boundary of active area.

Area-(C): Pressing Prohibited Area. The area is prohibited pressing because the excessive load will damage transparent electrode and touch panel function. This area is about 0.5mm outside from the boundary of Area-(B) the operation non-guaranteed area”

Area-(D) : Non-Active area (Frame). The area does not activate even if pressed.

Note: In order to prevent unusual performance degradation and malfunction of touch panel, please check the design of bezel and touch panel installation methods after surely confirming the Installing and Assembling as below:

- 1) Do not give excessive strain to the product
- 2) Tail cable is connected to the body by heat-seal (thermal pressure) method. So, do not apply excessive forces to the cable.

【Inhibition】

Do not add an excessive force to a FPC (Flex tail) that makes peeling off of the FPC from the product as the manner shown in the following figures:

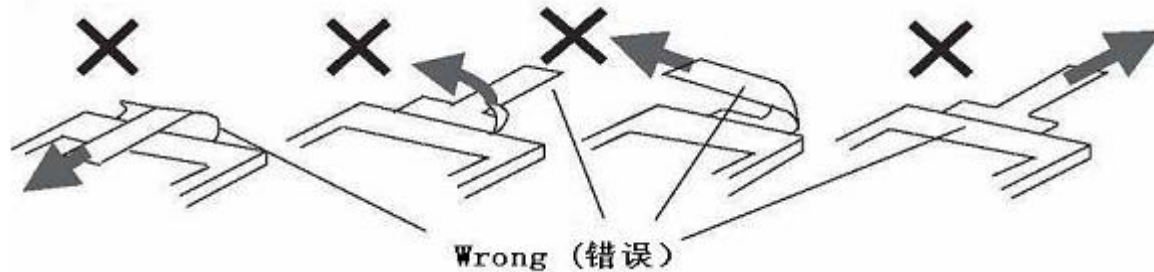

Do not adhere or mount any additional film or plate on the FPC as shown in below, because such additional goods apply a stress on the tip of FPC and it may tear off the root of FPC from touch panel.

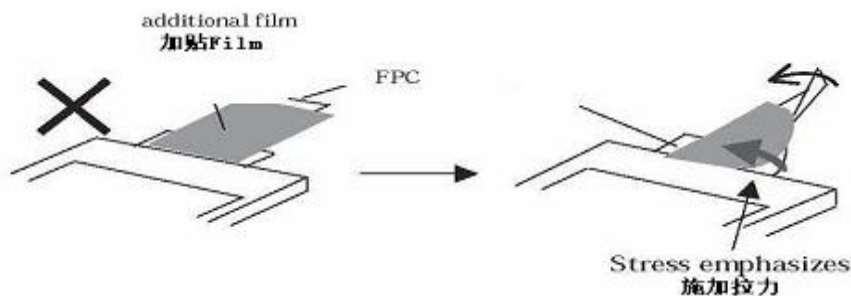

- 3) The transparent touch panel has air groove. Therefore please design the bezel structure to prevent any liquid or any fine particles.
- 4) Please provide 0.2mm-0.5mm gap between touch panel and bezel when design the case in order to prevent the any force on the surface of the touch panel.

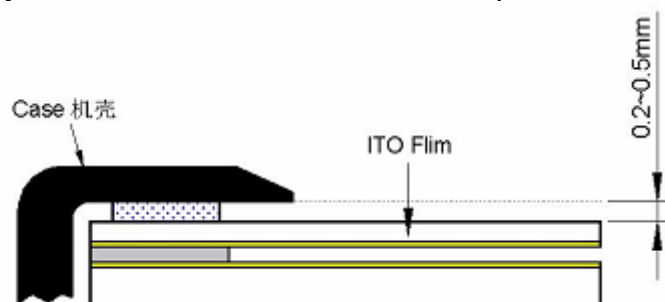

- 5) We recommend that bezel's opening edge covers the boundary of the active area when design the case in order to prevent an operation at outside of the active area and may cause serious damage to the transparent electrode.

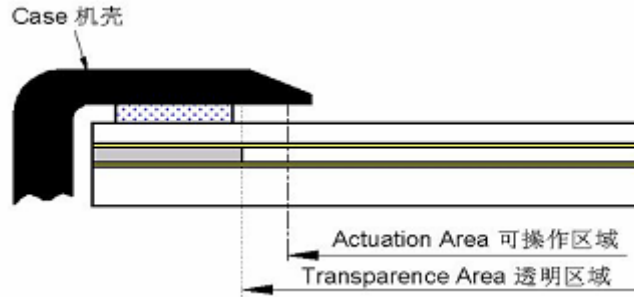

- 6) a. When design assembly unit, please add the gasket/cushion (C) outside area of portion (A) as shown in below to avoid any pressing on the portion (A). The area (B) shall be free from burr. The gasket/cushion material at the part (C) should not be exceeded to inside of the boundary of portion (A).

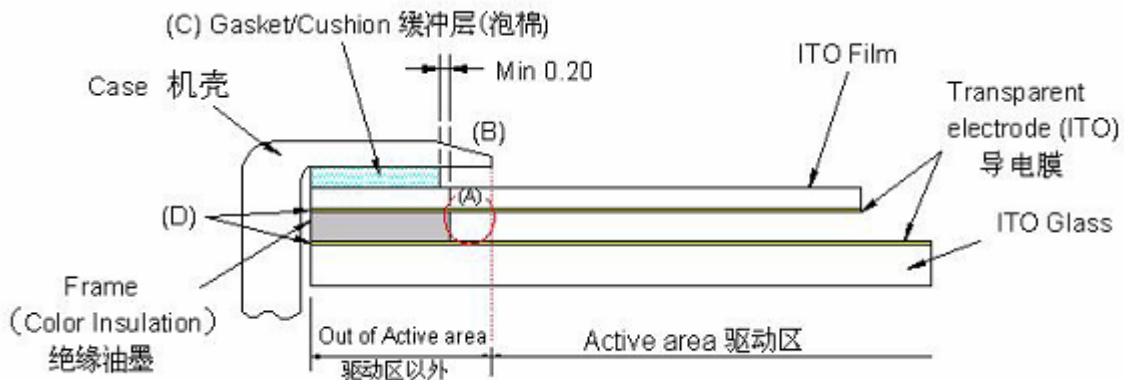

Please do not make the following mistake:

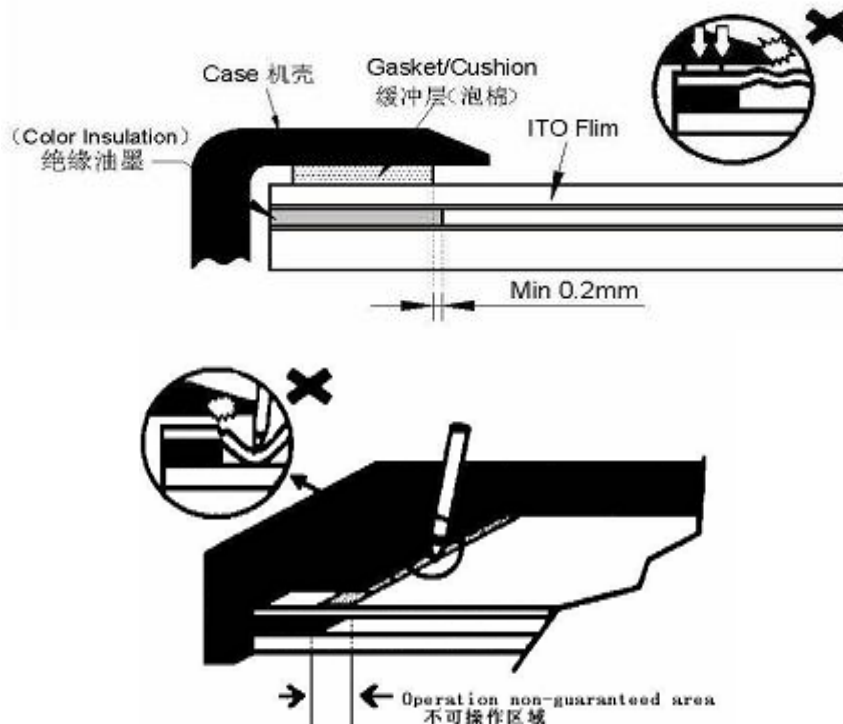

b. Since ITO film and glass are not eliminated at the edge, therefore please don't design any conductive material touching the edge of touch panel.

【Inhibition】

To prevent giving distortion to the ITO film of the product and peeling off of the film from the product, do not put any adhesive on the film adhered to the case.

- 7) When designing the case to mount touch panel, a clearance of 0.2-0.3mm between touch panel and inside boundary of case should be considered.

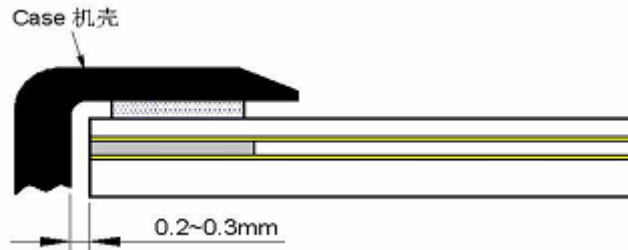

Meanwhile, in order to avoid touch panel any failure for extra wrap tail, please take care of keeping clearance of 2.0min.between tail portion and inside boundary of case when the touch panel is built into case.

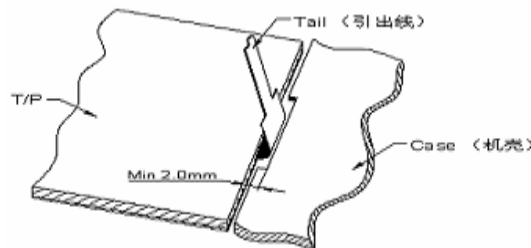

- 8) Please keep your case flat in order to prevent touching with T/P directly, which may seriously damage the transparent electrode.

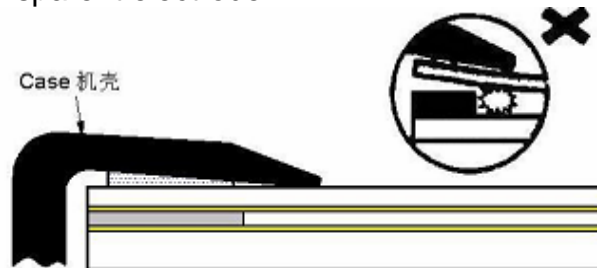

- 9) Wipe off the stains on the product by using soft cloth moistened with ethanol. Be careful do not to allow ethanol soaking into the joint of upper film and bottom glass. It may otherwise cause peeling off and defective operation.

【Inhibition】

Do not use any organic solvent or detergent other than ethanol.

- 10) The corners of the product are not chamfered. When positioning or fixing the product on the case, we suggest that you would provide an R part on the corner of the case so that no load will apply to the corners of the touch panel.

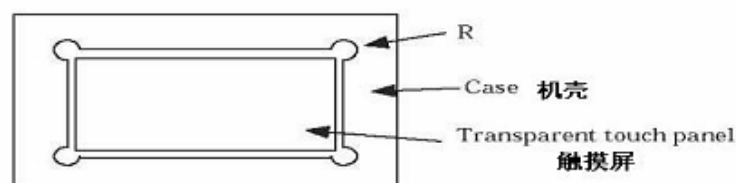

【Inhibition】

Do not press the film of the product when this product is built into a set.

11) When customer asks to put protection film on the touch panel, please confirm it will not affect the performance of touch panel. Some changes may arise in the characteristics of this product by adding such protection film such as operation, cosmetic, etc.. However, those changes are out of our guarantee.

Even when adding a protection film with adhesion material by company based on the request from customer, it may affect the performance of touch panel such as operation, cosmetic, etc. However, those changes are out of our guarantee.

12) When this product is mounted on the LCD or other display by using a double-sided tape etc., put an enough pressure onto the non-active area (Frame) of a touch panel so that neither exfoliation nor gap may take place between a touch panel and LCD or other target. When assembling, please apply pressure equally onto the corner part and four sides of a touch panel.

Area-(B) + Area-(C) : Sensitive area. Area-(B) and area-(C) are both sensitive areas. There is a clearance between top and bottom contact side in these areas. Hard pressing will cause transparent electrode crack and malfunction of touch panel. Please take fully consideration about this sensitive area when designing the case to prevent user touch this area.

Note: Please apply a layer of gasket cushion around bezel before assembling touch panel. The gasket cushion should be out side of viewable area at least 0.2mm from the boundary of viewable area:

① If bezel's opening is bigger than active area's size, the user could touch sensitive area and may damage the touch panel;

② If bezel's opening is smaller than active area's size, ITO transparent electrode will not be damaged when sliding on the edge of bezel's opening because sensitive area is covered by bezel around. But gasket's thickness will be applied when bezel's edge enters the active area. The gasket's thickness should keep 0.2~0.3mm gap between bezel and panel.

● PACKAGE DRAWING

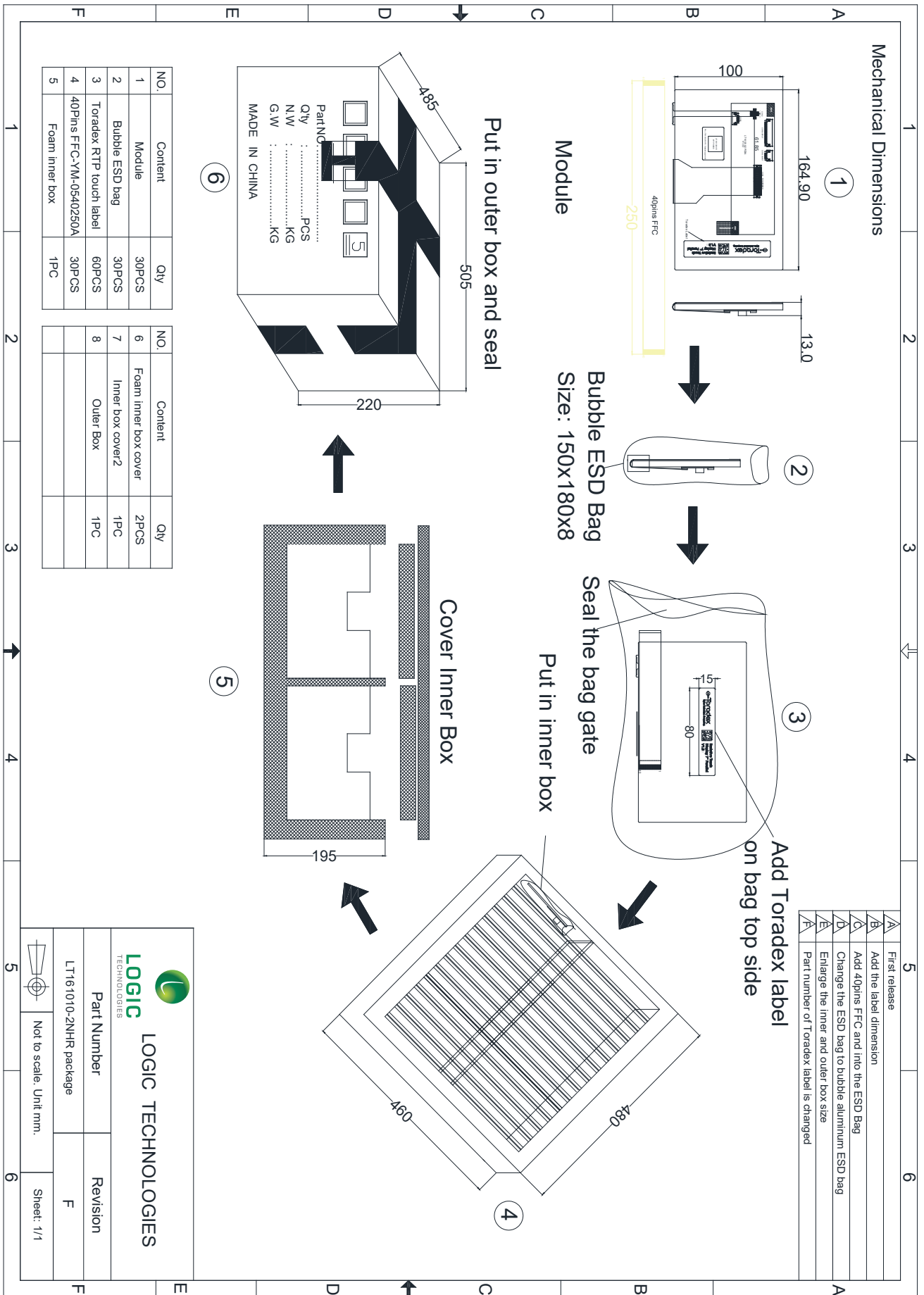

Note: Bubble ESD bag and packaging steps.

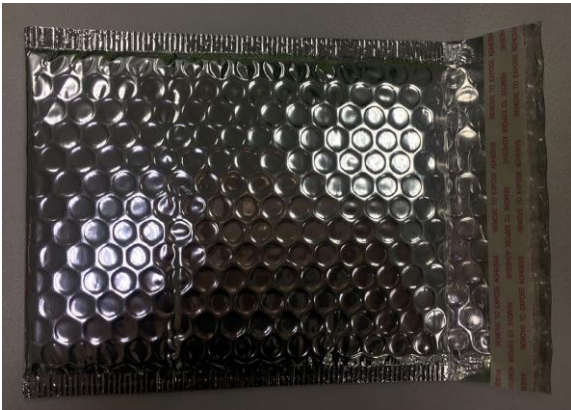

1). Bubble ESD Bag



2). Insert Display and FFCs



3). Seal the gate with tape



4). Add the label on top



5). Put the modules into inner foam box

- RELIABILITY TESTING

NO.	Item	Condition	Criteria
1	High Temperature Operating	70°C +/-2°C, 240Hrs	IEC60068-2-1, GB2423.2
2	Low Temperature Operating	-20°C +/-2°C, 240Hrs	IEC60068-2-1 GB2423.1
3	High Temperature Storage	80°C +/-2°C, 240Hrs	IEC60068-2-1 GB2423.2
4	Low Temperature Storage	-30°C +/-2°C, 240Hrs	IEC60068-2-1 GB2423.2
5	Hi Temperature & High Humidity Operation	50°C, 90%RH max, 240Hrs	IEC60068-2-78 GB/T2423.3
6	Vibration (non operating)	Frequency range:10 ~ 55Hz, Stroke:1.5mm Sweep:10Hz ~ 55Hz ~ 10Hz2hours for each direction of x.y.z (6 hours for total)	IEC60068-2-6 GB/T2423.10
7	Package Vibration Test	Random Vibration: 0.015GxG/Hz for 5-200Hz, -6dB/Octave from 200-500Hz 2 hours for each direction of X,Y,Z (6 hours for total)	IEC60068-2-34 GB/T2423.11
8	Thermal Shock (non operating)	-30°C to 30min to 80°C, 30min Change time: 5min, 100 cycles	Start with cold temperature, End with high temperature, IEC60068-2- 14:1984,GB2423.22
9	Drop Test (packaged)	Height:80 cm, 1 corner, 3 edges, 6 surfaces	IEC60068-2-32 GB/T2423.8
10	Shock (non-operation)	80G 6ms, ±X,±Y,±Z 3 times for each direction	IEC60068-2-27 GB/T2423.5
11	ESD (operation)	C=150pF,R=330Ω, Air:±15Kv, Contact:±8Kv, 10times/terminal	IEC61000-4-2 GB/T17626.2

Notes:

1. Test samples are applied to one test item.
2. Sample size for each test item is 2-10pcs.
3. For humidity testing, a pure water resistance of >10MW should be used.

4. (a) In the case of a malfunction caused by ESD damage, if the LCM returns to it's normal state after resetting, the item is considered to have passed the ESD test.
- (b) It is recommended to use an anti-static blower (ioniser) to reduce the electro-static voltage in the working area.
- (c) When removing the protection film from the LCM panel, peel off the film slowly (more than 1sec) while blowing the ioniser towards the peeling area to minimize ESD. This will reduce the risk of damaging the electrical circuitry.
5. EL backlights are exempt from the reliability testing with respect to temperature and humidity. Some defects many occur such as black spots or blemishes due to the inherent chemical reaction of humidity with fluorescent EL.
6. If it is installed, please use the automatic test mode on the LCM &/or demonstration box when testing.

• INSPECTION CRITERIA

This specification is designed to be used as the standard acceptance/rejection criteria for normal LCM products.

1. Sampling plan.

The sampling plan according to GB/T 2828.1-2003 / ISO2859-16 1999 and ANSI/ASQC Z1.4 1993, normal level 2 and based on:

- Major defect: AQL 0.65
- Minor defect: AQL 1.5

2. Inspection condition

- The viewing distance for cosmetic inspection is approximately 30cm with the naked eye, and under an environment of 20-40W light intensity, in all directions, within 45° against a perpendicular line. (Normal temperature 20-25°C and normal humidity 60+/-15 RH.)
- Driving voltage - The Vop value from which the most optimal contrast can be obtained near the specified Vop in the specification (within +/-0.5V of the typical value at 25°C.)

3. Definition of inspection zone in LCD.

Zone A : active pixel area

Zone B : viewing area except Zone A (Zone A + Zone B = Minimum viewing area)

Zone C : Outside viewing area (invisible area after assembling customer's product.

Figure 4 inspection zones in an LCD

Figure 4

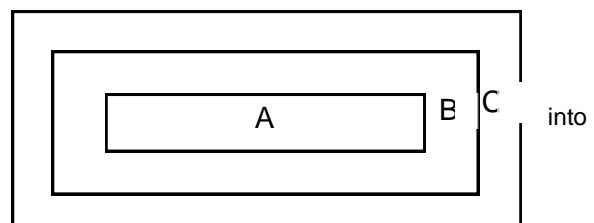

Note: As a general rule visual defects in Zone C are permissible when there is no visual effect once assembled into the customer's product.

● INSPECTION STANDARD

MAJOR CRITERIA

Item No	Item to be inspected	Inspection standard	Classification
1	All functional defects	1) No display 2) Display abnormal 3) Missing vertical or horizontal segment 4) Short circuit 5) Backlight not working, flickering and abnormal light	Major
2	Missing	Missing component	
3	Outline dimension	Overall outline dimension beyond the drawing dimension is not allowed	

COSMETIC CRITERIA

No.	Item	Judgment Criteria	Partition
1	Difference in Spec.	None allowed	Major
2	Pattern peeling	No substrate pattern peeling and floating	Major
3	Soldering defects	No soldering missing No soldering bridge No cold soldering	Major Major Minor
4	Resist flaw on substrate	Invisible copper foil (Ø0.5mm or more) on substrate pattern	Minor
5	Accretion of metallic Foreign matter	No soldering dust No accretion of metallic foreign matters (Not exceed Ø0.2mm)	Minor Minor
6	Stain	No stain to spoil cosmetic badly	Minor
7	Plate discoloring	No plate fading, rusting and discoloring	Minor
8	Solder amount 1. Lead parts	a. Soldering side of PCB Solder to form a 'Filet' all around the lead. Solder should not hide the lead form perfectly. (too much) b. Components side (In case of 'Through Hole PCB') Solder to reach the Components side of PCB.	Minor
	2. Flat packages	Either 'toe' (A) or 'heel' (B) of the lead to be covered by 'Filet'. Lead form to be assume over solder.	
	3. Chips	$(3/2) H \geq h \geq (1/2) H$	Minor
9	Solder ball/solder splash	a) The spacing between solder ball and the conductor or solder pad $h \geq 0.13\text{mm}$. The diameter of the solder ball $d \leq 0.15\text{mm}$. b) The quantity of solder balls or solder splashes isn't more than 5 in 600mm ² . c) Solder balls / splashes do not violate minimum electrical clearance d) Solder balls/splashes must be not be able to be dislodged with normal product usage	Minor Minor Major Minor

COSMETIC CRITERIA (non-operating)

No.	Defect	Judgment Criteria	Classification										
1	Spots	In accordance with Screen Cosmetic Criteria (Operating) No.1.	Minor										
2	Lines	In accordance with Screen Cosmetic Criteria (Operating) No.2.	Minor										
3	Bubbles in polarizer	<table border="1"> <thead> <tr> <th>Size : d mm</th> <th>Acceptable Qty in active area</th> </tr> </thead> <tbody> <tr> <td>$d \leq 0.3$</td> <td>Disregard</td> </tr> <tr> <td>$0.3 < d \leq 1.0$</td> <td>3</td> </tr> <tr> <td>$1.0 < d \leq 1.5$</td> <td>1</td> </tr> <tr> <td>$1.5 < d$</td> <td>0</td> </tr> </tbody> </table>	Size : d mm	Acceptable Qty in active area	$d \leq 0.3$	Disregard	$0.3 < d \leq 1.0$	3	$1.0 < d \leq 1.5$	1	$1.5 < d$	0	Minor
Size : d mm	Acceptable Qty in active area												
$d \leq 0.3$	Disregard												
$0.3 < d \leq 1.0$	3												
$1.0 < d \leq 1.5$	1												
$1.5 < d$	0												
4	Scratch	In accordance with spots and lines operating cosmetic criteria. When the light reflects on the panel surface, the scratches are not to be remarkable.	Minor										
5	Allowable density	Above defects should be separated more than 30mm each other.	Minor										
6	Coloration	Not to be noticeable coloration in the viewing area of the LCD panels. Back-lit type should be judged with back-lit on state only.	Minor										
7	Contamination	Not to be noticeable.	Minor										

COSMETIC CRITERIA (operating)

No.	Defect	Judgment Criteria	Classification																				
1	Spots	<p>A) Clear</p> <table border="1"> <thead> <tr> <th>Size : d mm</th> <th>Acceptable Qty in active area</th> </tr> </thead> <tbody> <tr> <td>$d \leq 0.1$</td> <td>Disregard</td> </tr> <tr> <td>$0.1 < d \leq 0.2$</td> <td>6</td> </tr> <tr> <td>$0.2 < d \leq 0.3$</td> <td>2</td> </tr> <tr> <td>$0.3 < d$</td> <td>0</td> </tr> </tbody> </table> <p>Note : Including pin holes and defective dots which must be within one pixel size.</p> <p>B) Unclear</p> <table border="1"> <thead> <tr> <th>Size : d mm</th> <th>Acceptable Qty in active area</th> </tr> </thead> <tbody> <tr> <td>$d \leq 0.2$</td> <td>Disregard</td> </tr> <tr> <td>$0.2 < d \leq 0.5$</td> <td>6</td> </tr> <tr> <td>$0.5 < d \leq 0.7$</td> <td>2</td> </tr> <tr> <td>$0.7 < d$</td> <td>0</td> </tr> </tbody> </table>	Size : d mm	Acceptable Qty in active area	$d \leq 0.1$	Disregard	$0.1 < d \leq 0.2$	6	$0.2 < d \leq 0.3$	2	$0.3 < d$	0	Size : d mm	Acceptable Qty in active area	$d \leq 0.2$	Disregard	$0.2 < d \leq 0.5$	6	$0.5 < d \leq 0.7$	2	$0.7 < d$	0	Minor
Size : d mm	Acceptable Qty in active area																						
$d \leq 0.1$	Disregard																						
$0.1 < d \leq 0.2$	6																						
$0.2 < d \leq 0.3$	2																						
$0.3 < d$	0																						
Size : d mm	Acceptable Qty in active area																						
$d \leq 0.2$	Disregard																						
$0.2 < d \leq 0.5$	6																						
$0.5 < d \leq 0.7$	2																						
$0.7 < d$	0																						

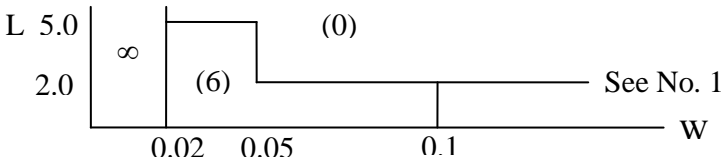
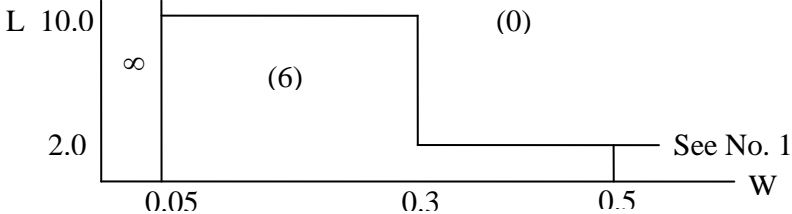
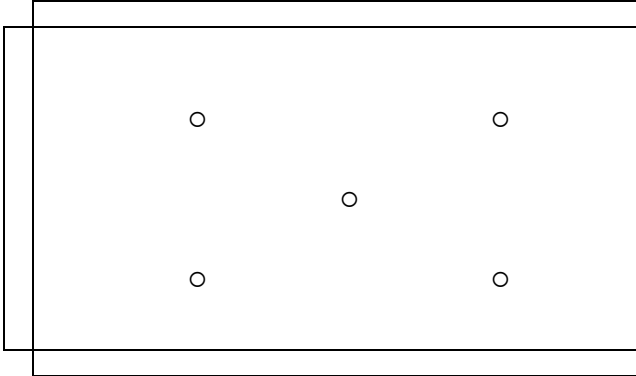
2	Lines	<p>A) Clear</p>  <p>Note : () - Acceptable Qty in active area L - Length (mm) W - Width (mm) ∞ - Disregard</p> <p>B) Unclear</p> 	Minor
3	Rubbing line	Not to be noticeable.	
4	Allowable density	Above defects should be separated more than 10mm each other.	Minor
5	Rainbow	Not to be noticeable.	Minor
6	Dot size	To be 95% ~ 105% of the dot size (Typ.) in drawing. Partial defects of each dot (ex. pin-hole) should be treated as 'spot'. (see Screen Cosmetic Criteria (Operating) No.1)	Minor
7	Uneven brightness (only back-lit type module)	<p>Uneven brightness must be $B_{MAX} / B_{MIN} \leq 2$</p> <ul style="list-style-type: none"> - BMAX : Max. value by measure in 5 points - BMIN : Min. value by measure in 5 points <p>Divide active area into 4 vertically and horizontally. Measure 5 points shown in the following figure.</p>  <p>○ : Measuring points</p>	Minor

Note :

- (1) Size : $d = (\text{long length} + \text{short length}) / 2$
- (2) The limit samples for each item have priority.
- (3) Complex defects are defined item by item, but if the number of defects are defined in above table, the total number should not exceed 10.
- (4) In case of 'concentration', even the spots or the lines of 'disregarded' size should not allowed.

Following three situations should be treated as 'concentration'.

- 7 or over defects in circle of $\varnothing 5\text{mm}$.
- 10 or over defects in circle of $\varnothing 10\text{mm}$.
- 20 or over defects in circle of $\varnothing 20\text{mm}$.

PRECAUTIONS FOR USING LCD MODULES

Handling Precautions

- (1) The display panel is made of glass. Do not subject it to a mechanical shock by dropping it or impact.
- (2) If the display panel is damaged and the liquid crystal substance leaks out, be sure not to get any in your mouth. If the substance contacts your skin or clothes, wash it off using soap and water.
- (3) Do not apply excessive force to the display surface or the adjoining areas since this may cause the color tone to vary.
- (4) The polarizer covering the display surface of the LCD module is soft and easily scratched. Handle this polarizer carefully.
- (5) If the display surface becomes contaminated, breathe on the surface and gently wipe it with a soft dry cloth. If it is heavily contaminated, moisten cloth with one of the following solvents :
 - Isopropyl alcohol
 - Ethyl alcohol
- (6) Solvents other than those above-mentioned may damage the polarizer. Especially, do not use the following.
 - Water
 - Ketone
 - Aromatic solvents
- (7) Exercise care to minimize corrosion of the electrode. Water droplets, moisture condensation or a current flow in a high-humidity environment, accelerate corrosion of the electrodes.
- (8) Install the LCD Module by using the mounting holes. When mounting the LCD module ensure it is free of twisting, warping or distortion. In particular, do not forcibly pull or bend the I/O cable or the backlight cable.
- (9) Do not attempt to disassemble or process the LCD module.
- (10) NC terminal should be open. Do not connect anything.
- (11) If the logic circuit power is off, do not apply the input signals.
- (12) To prevent destruction of the elements by static electricity, be careful to maintain an optimum work environment.
 - Be sure to ground the body when handling the LCD modules.
 - Tools required for assembling, such as soldering irons, must be properly grounded.
 - To reduce the amount of static electricity generated, do not conduct assembling and other work under dry conditions.
 - The LCD module is coated with a film to protect the display surface. Exercise care when peeling off this protective film since static electricity may be generated.

Storage Precautions

When storing the LCD modules, avoid exposure to direct sunlight or to the light of fluorescent lamps. Keep the modules in bags (avoid high temperature / high humidity and low temperatures below the stated storage temperature of the LCM specification).

Others

Liquid crystals solidify under low temperature (below the storage temperature range) leading to defective orientation or the generation of air bubbles (black or white). Air bubbles may also be generated if the module is subject to a low temperature.

If the LCD modules have been operating for a long time showing the same display patterns, the display patterns may remain on the screen as ghost images and a slight contrast irregularity may also appear. A normal operating status can be regained by suspending use for some time. It should be noted that this phenomenon does not adversely affect performance reliability.

To minimize the performance degradation of the LCD modules resulting from destruction caused by static electricity etc., exercise care to avoid holding the following sections when handling the modules.

- Exposed area of the printed circuit board.
- Terminal electrode sections.

USING LCD MODULES

Liquid Crystal Display Modules

LCD is composed of glass and polarizer. Pay attention to the following items when handling.

(1) Please keep the temperature within specified range for use and storage. Polarization degradation, bubble generation or polarizer peel-off may occur with high temperature and high humidity.

(2) Do not touch, push or rub the exposed polarizers with anything harder than an HB pencil lead (glass, tweezers, etc.).

(3) N-hexane is recommended for cleaning the adhesives used to attach front/rear polarizers and reflectors made of organic substances that may be damaged by chemicals such as acetone, toluene, ethanol and isopropyl alcohol.

(4) When the display surface becomes dusty, wipe gently with absorbent cotton or other soft material like chamois soaked in petroleum benzene. Do not scrub hard to avoid damaging the display surface.

(5) Wipe off saliva or water drops immediately, contact with water over a long period of time may cause deformation or color fading.

(6) Avoid contacting oil and fats.

(7) Condensation on the surface and contact with terminals due to cold will damage, stain or dirty the polarizers. After products are tested at low temperature they must be warmed up in a container before coming in contact with room temperature air.

(8) Do not put or attach anything on the display area to avoid leaving marks on.

(9) Do not touch the display with bare hands. This will stain the display area and degrade the insulation between the terminals.

(10) As glass is fragile. It tends to become chipped during handling especially on the edges.

(11) Mounting Method

The panel of the LCD Module consists of two thin glass plates with polarizers, which easily get damaged. Since the Module is fixed by utilizing fitting holes in the printed circuit board.

Extreme care should be taken when handling the LCD Modules.

(12) Caution against static charge

The LCD Module use C-MOS LSI drivers, so we recommend that you connect any unused input terminal to VDD or VSS, do not input any signals before power is turned on. And ground your body, Work/assembly table. And assembly equipment to protect against static electricity.

Precaution for Soldering the LCM

	Manual Soldering	Machine Drag Soldering	Machine Pre-soldering
Non ROHS Product	290°C ~ 350°C Speed : 3 ~ 5 mm/s	330°C ~ 350°C Speed : 4 ~ 8mm/s	300°C ~ 330°C Time : 3 ~ 6S Pressure : 0.8 to 1.2Mpa
RoHS Product	340°C ~ 370°C Time : 3 ~ 5S.	350°C ~ 370°C Time : 4 ~ 8 mm/S.	330°C ~ 360°C Time : 3 ~ 6S. Pressure : 0.8 ~ 1.2Mpa.

(1) If solder flux is used, be sure to remove any remaining flux after finishing the soldering process. (This does not apply in the case of a non-halogen type of flux.) It is recommended that you protect the LCD surface with a cover during the soldering process to prevent any damage due to the flux sparks.

(2) When soldering a backlight panel and PCB, the panel and PCB should not be detached more than 3 times. The temperature determines this number and time conditions as mentioned in the

above table, although there may be some variance depending on the actual temperature of the soldering iron.

- (3) When removing a backlight panel from the PCB, ensure the solder has completely melted, otherwise the solder pads on the backlight panel and/or PCB may be damaged.

Caution for operation

(1) It is recommended to drive LCDs within their specified voltage limit since the higher voltage than the upper limit shortens the LCD life. An electrochemical reaction due to direct current causes the LCD to deteriorate. Therefore, avoid the use of direct current drive.

(2) Response time will be extremely delayed at lower temperatures than the operating temperature range. At higher temperatures LCD's will experience a dark color. However those phenomena do not mean a malfunction or the LCD's. Once the LCDs are returned to the specified operating temperature range, the response time and colouration should return to the normal state.

(3) If the display area is physically pressed hard during it's operation, some pixels may be abnormally displayed, but should return to their normal condition after resetting the LCM.

(4) Moisture sitting on the LCM terminals is a cause for an electro-chemical reaction resulting in a terminal open circuit. Usage under the relative condition of 40°C, 50%RH or less is therefore required.

Safety

- (1) It is recommended to crush any damaged or unnecessary LCDs into pieces and wash off the liquid crystal by using solvents such as acetone and ethanol, which should then be burned up later.
- (2) When any liquid crystal has leaked out of a damaged glass cell and comes in contact with skin, please wash it off well with soap and water.

Warranty

Unless otherwise agreed between Logic Technologies Ltd and the customer, Logic Technologies will replace or repair any of its products that are found to be functionally defective when inspected in accordance with Logic Technologies' acceptance criteria (copies available upon request) for a period of one year from date of shipment. Cosmetic/visual defects must be returned to Logic Technologies within 90 days of shipment. Confirmation of such date shall be based on freight documents. The warranty liability of Logic Technologies is limited to the repair and/or replacement on the terms set forth above. Logic Technologies will not be responsible for any subsequent or consequential losses and/or events.

Returning products under warranty

No warranty can be granted if the precautions stated above have been disregarded. The typical examples of violations are:

- Broken LCD glass.
- PCB eyelet's damaged or modified.
- PCB conductors damaged.
- Circuit modified in any way, including addition of components.
- PCB tampered with by grinding, engraving or painting varnish.
- Soldering to or modifying the bezel in any manner.

Product repairs will be invoiced to the customer upon mutual agreement. Products must be returned with sufficient description of the failures and/or defects. Any connectors or cable installed by the customer must be removed completely without damaging the PCB eyelet's, conductors and terminals.

DISCLAIMER

Copyright © Toradex AG. All rights are reserved. The information and content in this document are provided "as-is" with no warranties of any kind and are for informational purposes only. Data and information have been carefully checked and are believed to be accurate; however, no liability or responsibility for any errors, omissions or inaccuracies is assumed.

Brand and product names are trademarks or registered trademarks of their respective owners. Specifications are subject to change without notice.