

Circuit Breaker for Equipment thermal, 3 pole, Push button actuation



Basic type



With auxiliary contact



With undervoltage protection

See below:

Approvals and Compliances

Description

- Thermal circuit breaker
- 2 pole thermal overload protection
- Positively trip-free release
- High configurability
- Snap-in or flange mounted
- Quick connect terminal 6.3 x 0.8 mm or screw clamp terminal M3.5 x 6 mm (lineside P1, P2)

Applications

- Power tools
- Industrial appliances
- Power supplies
- Equipment for construction
- Cleaning equipment

Weblinks

[pdf data sheet](#), [html datasheet](#), [General Product Information](#), [Distributor-Stock-Check](#), [Detailed request for product](#), [Product News](#)

Technical Data

Rated Voltage AC	AC 400 VAC
Rated current range AC	0.05 - 12 A
Conditional short circuit capacity Icn	IEC 60934: PC1, AC 400 V: 1kA
Short circuit capacity Icn	IEC 60934: 400 VAC: 10x In (max. 3 Zykl.)
Degree of Protection	front side IP40 acc. to IEC 60529
Dielectric Strength	4 kVAC
Insulation Resistance	500VDC > 100 MΩ
Lifetime	mechanical: 50'000 switching cycles AC: 1.0 x Ir: 50'000 switching cycles

Overload	AC: min. 40trips @ 6 x Ir
Allowable Operation Temp.	-10°C to 55°C
Storage Temperature	-10°C to 55°C
Vibration Resistance	± 0.75 mm @ 10 - 60 Hzacc. to IEC 60068-2-6, test Tc10 G @ 60 - 500 Hzacc. to IEC 60068-2-6, test Tc
Shock Resistance	30 G / 18msacc. to IEC 60068-2-27, test Ea
Tripping Type	Thermal
Actuation Type	Pushbutton
Weight	50 g - 55 g

Approvals and Compliances

Detailed information on product approvals, code requirements, usage instructions and detailed test conditions can be looked up in [Details about Approvals](#)

SCHURTER products are designed for use in industrial environments. They have approvals from independent testing bodies according to national and international standards. Products with specific characteristics and requirements such as required in the automotive sector according to IATF 16949, medical technology according to ISO 13485 or in the aerospace industry can be offered exclusively with customer-specific, individual agreements by SCHURTER.

Approvals





The approval mark is used by the testing authorities to certify compliance with the safety requirements placed on electronic products.

Approval Reference Type: TA45

Approval Logo	Certificates	Certification Body	Description
	VDE Approvals	VDE	VDE Certificate Number: 40019880
	UL Approvals	UL	UR File Number: E71572
	CCC Approvals	CCC	CCC Certificate Number: 2024010307710411

Product standards

Product standards that are referenced

Organization	Design	Standard	Description
	Designed according to	IEC 60934	Circuit-breakers for equipment (CBE)
	Designed according to	UL 1077	Standard for Supplementary Protectors for Use in Electrical Equipment
	Designed according to	CSA C22.2 No. 235	Supplementary Protectors
	Designed according to	GB 17701	Circuit-breaker for equipment





Application standards

Application standards where the product can be used

Organization	Design	Standard	Description
	Suitable for applications acc.	IEC/UL 62368-1	Audio/video, information and communication technology equipment - Part 1: Safety requirements

Compliances

The product complies with following Guide Lines

Identification	Details	Initiator	Description
	CE declaration of conformity	SCHURTER AG	The CE marking declares that the product complies with the applicable requirements laid down in the harmonisation of Community legislation on its affixing in accordance with EU Regulation 765/2008.
	UKCA declaration of conformity	SCHURTER AG	The UKCA marking declares that the product complies with the applicable requirements laid down in the British Amendment of Regulation (EC) 765/2008.
	RoHS	SCHURTER AG	Directive RoHS 2011/65/EU, Amendment (EU) 2015/863
	China RoHS	SCHURTER AG	The law SJ / T 11363-2006 (China RoHS) has been in force since 1 March 2007. It is similar to the EU directive RoHS.
	REACH	SCHURTER AG	On 1 June 2007, Regulation (EC) No 1907/2006 on the Registration, Evaluation, Authorization and Restriction of Chemicals 1 (abbreviated as "REACH") entered into force.

Dimension [mm]

Snap-in type and quick connect terminal

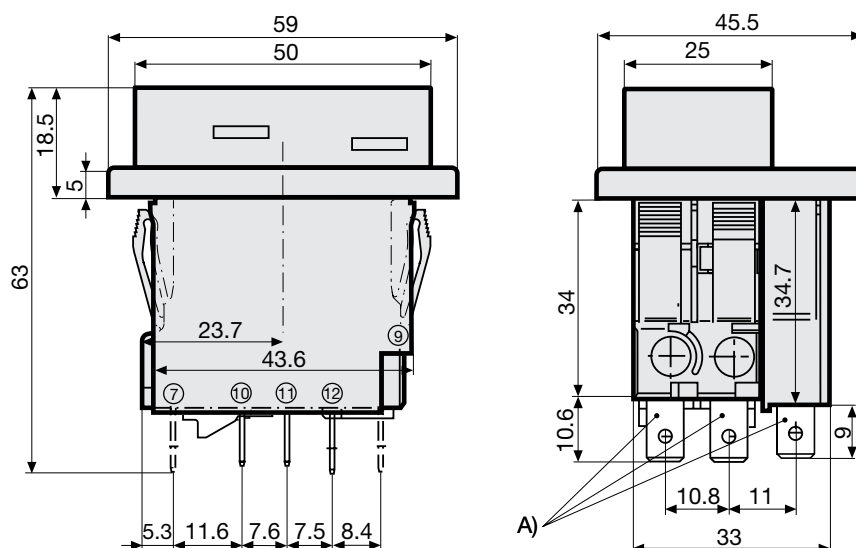

A) Quick connect terminal, IEC 61210, A6.3-0.8 mm

Snap-in type and screw clamp terminal

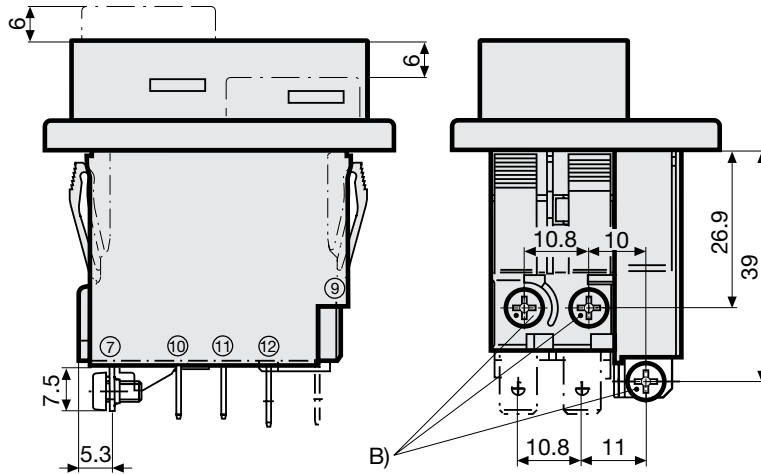

B) Screw type M3, 5x6 (Philips Form H), maximum torque 1 Nm

Snap-in type and quick connect terminal
 Undervoltage release, remote trip release

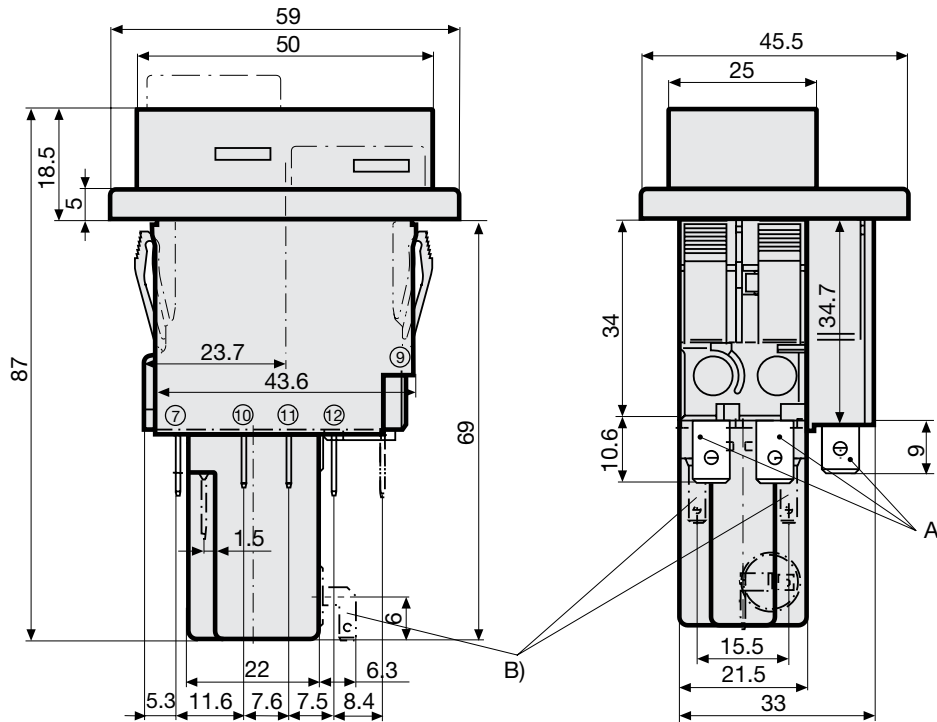

A) Quick connect terminal, IEC 61210, A6.3-0.8 mm

B) Quick connect terminal, IEC 61210, A2.8-0.8 mm

Snap-in type and quick connect terminal with auxiliary contact

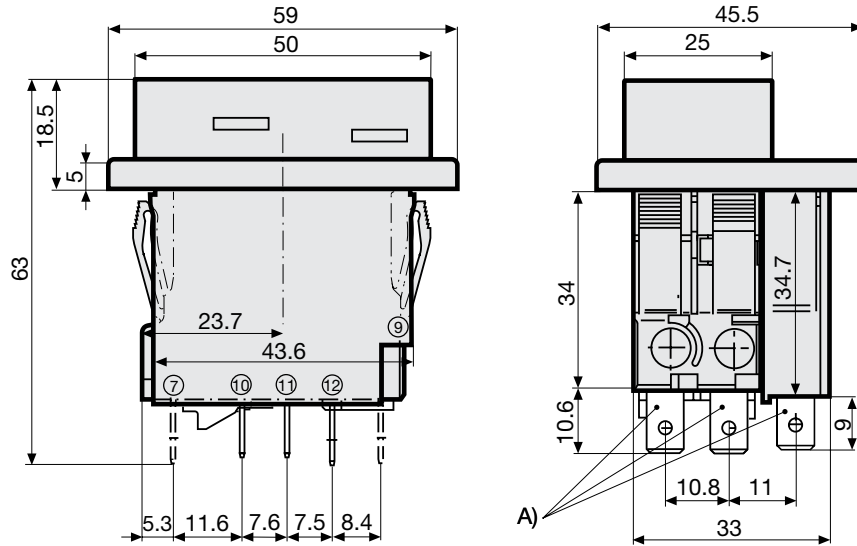

A) Quick connect terminal, IEC 61210, A6.3-0.8 mm

Snap-in type and screw clamp terminal with auxiliary contact

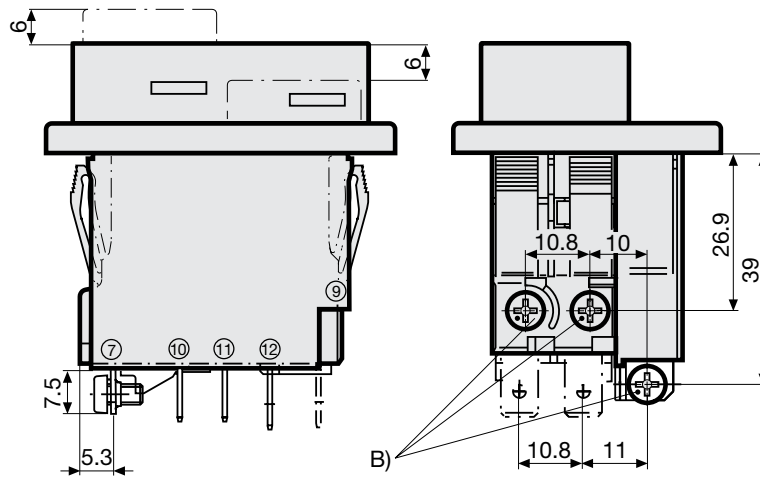

B) Screw type M3, 5x6 (Philips Form H), maximum torque 1 Nm

Snap-in type and quick connect terminal with auxiliary contact
 Undervoltage release, remote trip release

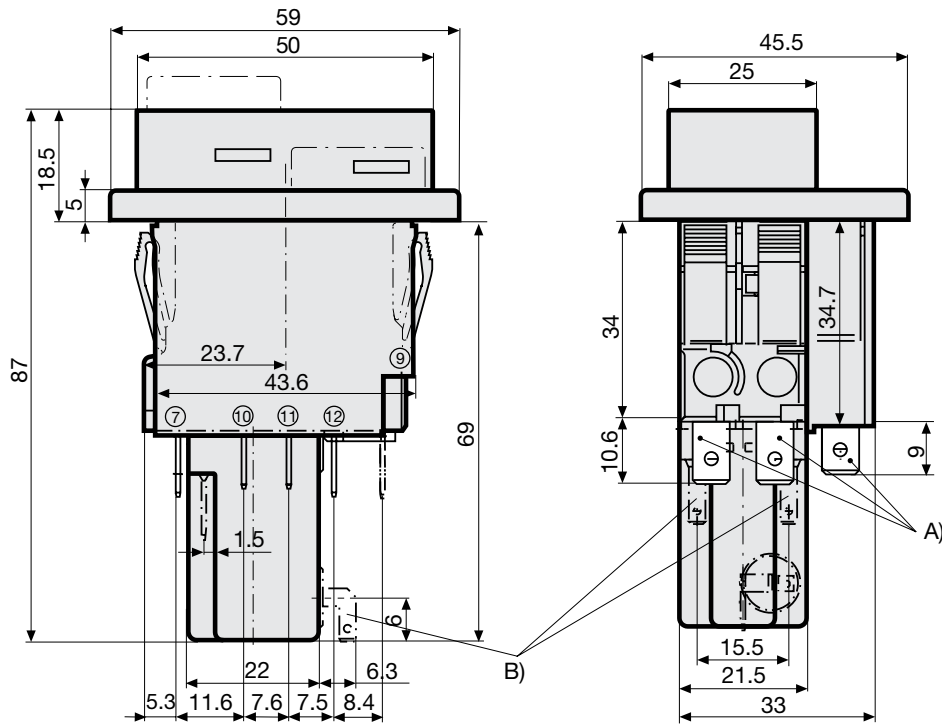

A) Quick connect terminal, IEC 61210, A6.3-0.8 mm
 B) Quick connect terminal, IEC 61210, A2.8-0.8 mm

Flange type and quick connect terminal

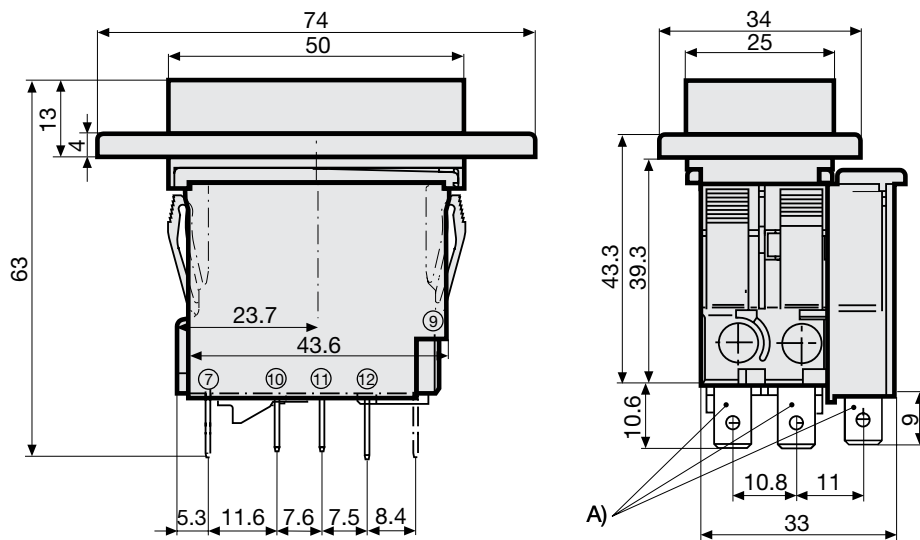

A) Quick connect terminal, IEC 61210, A6.3-0.8 mm

Flange type and screw clamp terminal

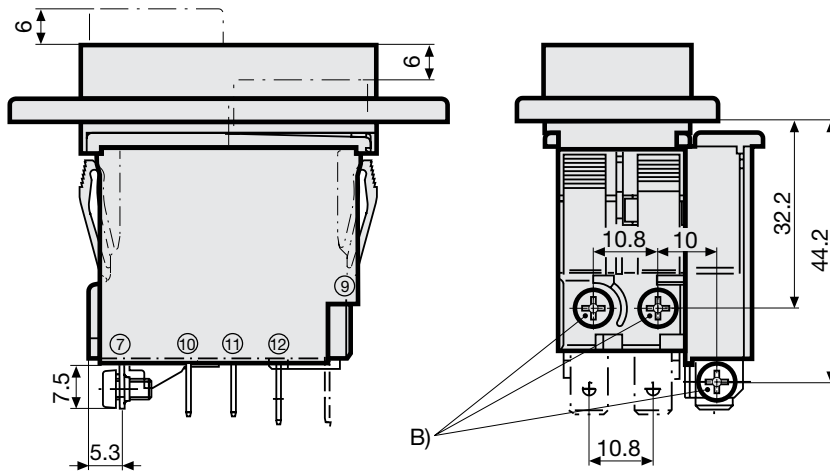

B) Screw type M3, 5x6 (Philips Form H), maximum torque 1 Nm

Flange type and quick connect terminal
 Undervoltage release, remote trip release

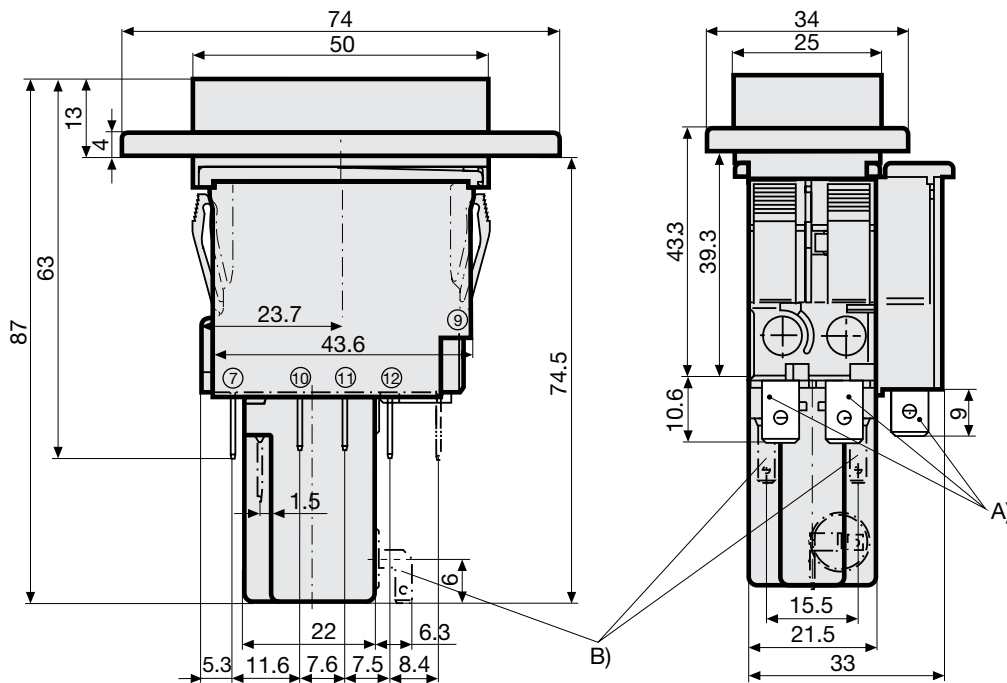

A) Quick connect terminal, IEC 61210, A6.3-0.8 mm

B) Screw type M3, 5x6 (Philips Form H), maximum torque 1 Nm

Flange type and quick connect terminal with auxiliary contact

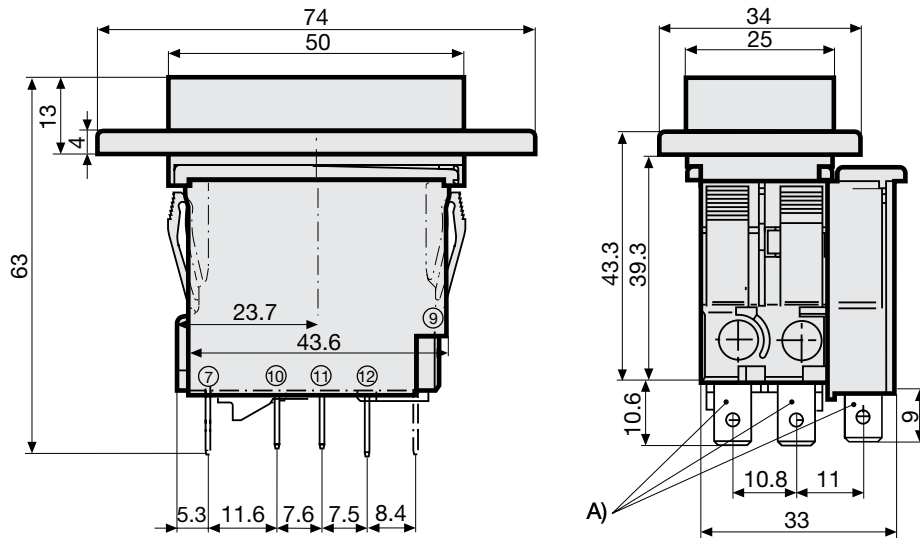

A) Quick connect terminal, IEC 61210, A6.3-0.8 mm

Flange type and screw clamp terminal with auxiliary contact

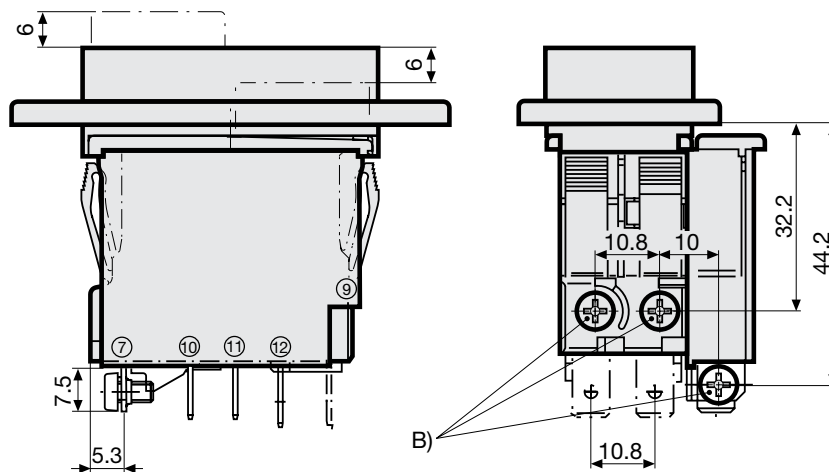

B) Screw type M3, 5x6 (Philips Form H), maximum torque 1 Nm

Flange type and quick connect terminal with auxiliary contact
 Undervoltage release, remote trip release

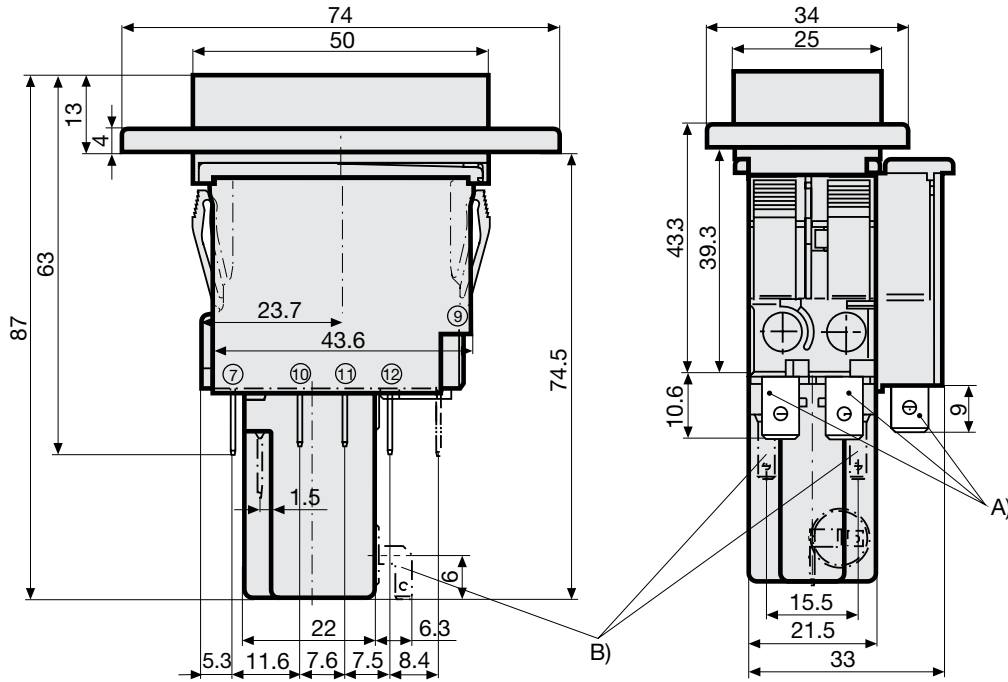

A) Quick connect terminal, IEC 61210, A6.3-0.8 mm
 B) Quick connect terminal, IEC 61210, A2.8-0.8 mm

Cut-out and pin-out

Cut-out snap-in type
 With auxiliary contact

Cut-out flange type / Installation from rear

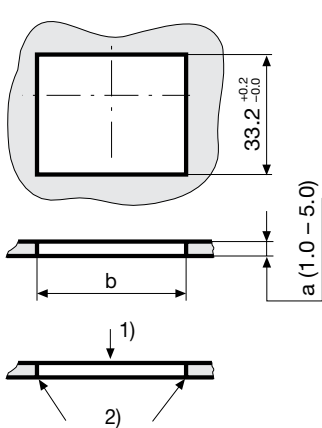

a	b
1.0	44,5...45,0
1.5	44,5...45,0
2.0	44,7...45,2
2.5	44,7...45,2
3.0	44,8...45,3
4.0	44,9...45,4
5.0	45,0...45,5

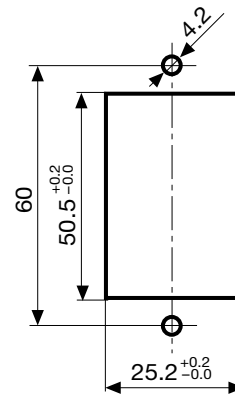

1) Assemble
 2) edge must be sharp

Cut-out flange type/ Installation from rear with AZZ05 cover

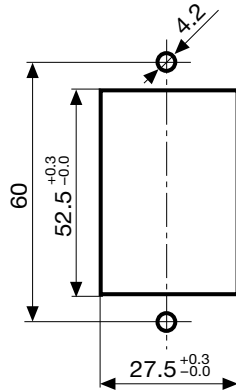

Pin-out
 With auxiliary contact

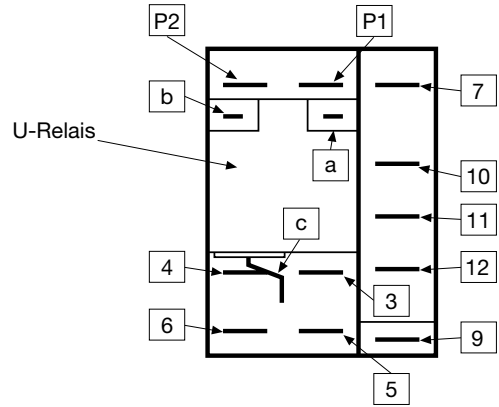

Time-Current-Curves

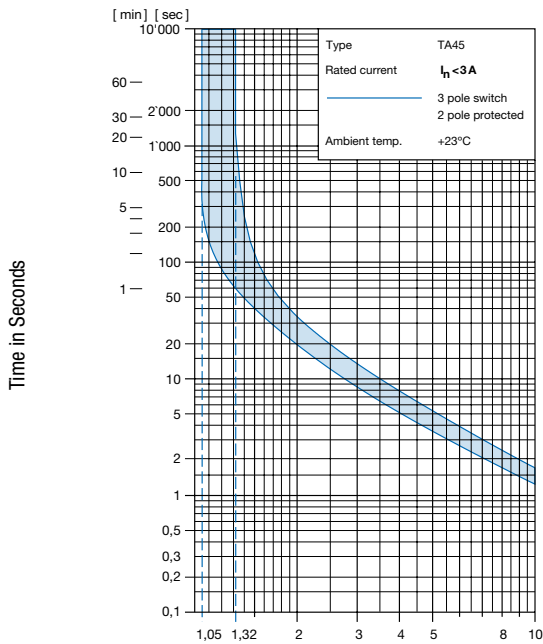

Multiple of Rated Current I_n

Ambient temperature +23°

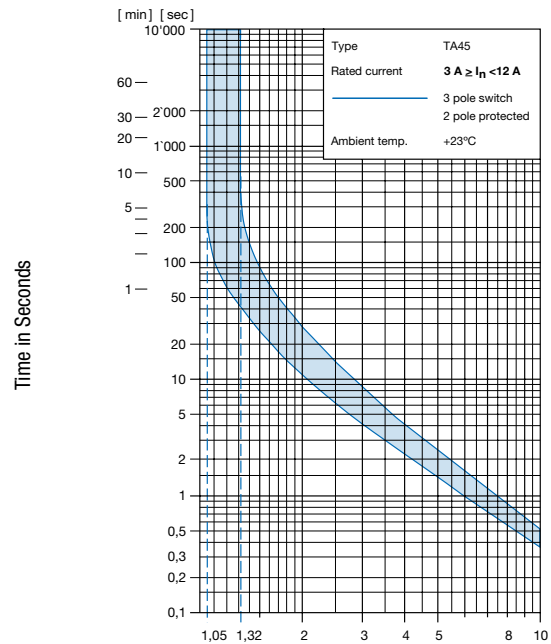

Multiple of Rated Current I_n

Ambient temperature +23°

Effect of ambient temperature

The units are calibrated for an ambient temperature of +23°C. To determine the rated current for a lower or higher ambient temperature, use a correction factor (typical value) from the table below:

Ambient Temperature [°C]	Correction factor
-10	0.89
-5	0.91
0	0.92
+23	1.00
+30	1.03
+40	1.08
+55	1.16

Example: With a nominal current of 5A and an ambient temperature of 40°C, a correction factor of 1.08 results. This results in a nominal current of 5.5 A, which is rounded up to the next higher nominal current 6 A.

Auxiliary contact (changeover)

Rated Voltage	28 VDC	60 VDC	240 VAC
Rated current	max. 10 A resistive load	max. 2 A resistive load	max. 2 A $\cos \varphi$ 0.7

Undervoltage release

Max. operating voltage	1.1 Ue						
Rated operating voltage Ue	5 V	12 V	24 V	48 V	120 V	240 V	400 V
Current consumption ($\pm 10\%$)	10.5 mA	16.5 mA	17.0 mA	3.2 mA	3.7 mA	3.1 mA	2.65 mA
Highest reset level	0.85 Ue	0.85 Ue	0.85 Ue	0.85 Ue	0.85 Ue	0.85 Ue	0.85 Ue
Lowest trip level	0.20 Ue	0.20 Ue	0.20 Ue	0.20 Ue	0.20 Ue	0.20 Ue	0.20 Ue
Trip delay	20 ms - 50 ms	20 ms - 50 ms	20 ms - 50 ms	20 ms - 50 ms	20 ms - 50 ms	20 ms - 50 ms	20 ms - 50 ms
Impulse withstand voltage (1.2 / 50 μ s)	≥ 4 kV	≥ 4 kV	≥ 4 kV	≥ 4 kV	≥ 4 kV	≥ 4 kV	≥ 4 kV

Remote trip

Permissible impuls duration of the make contact (no)	Between terminal C and P1	unlimited
Electrical load of the make contact (no)	Current max. 12 mA / power max. 1.1 W	

Order number key

T	A	4	5	-	A	B	L	T	F	2	0	0	U	2	-	7	0	1
						1	2	3	4	5							6*	

* These characters are omitted for standard products and serve as placeholder for customised applications.

Basic type

1

Auxiliary contact (changeover)	
Shunt terminal	
Schematic drawing	
Terminal type	Quick connect terminal Screw terminal (lineside P1, P2)
Snap-in type	Push button gasket IP40
	Push button gasket IP65
Flange type	Push button gasket IP40
	Push button gasket IP65

2-pole thermal overload protection							
•	•	•	•	•	•	•	•
ATN	AWN	ATP	AWP	AVN	AYN	AVP	AYP
ATW	AWW	ATX	AWX	AVW	AYW	AVX	AYX
AKN	ANN	AKP	ANP	AMN	ARN	AMP	ARP
AKW	ANW	AKX	ANX	AMW	ARW	AMX	ARX

Colours

2

Switch front	ON Button	OFF Button		
black	green	red	=	T

Push button legend

3

	Embossed	=	F
	Printed white	=	H
	Printed black	=	K
	Printed white	=	L
	Printed black	=	M
	Printed white	=	P
	Printed black	=	R
	Printed white	=	S
	Printed black	=	T

Rated current In [A]

4

Thermal overload protection														
In	Q	In	Q	In	Q	In	Q	In	Q	In	Q	In	Q	
0.05	=	Z05	0.5	=	J05	1.4	=	J14	2.3	=	J23	4.0	=	040
0.1	=	J01	0.6	=	J06	1.5	=	J15	2.5	=	J25	4.2	=	042
0.15	=	Z15	0.7	=	J07	1.6	=	J16	2.8	=	J28	4.4	=	044
0.2	=	J02	0.8	=	J08	1.7	=	J17	2.9	=	J29	4.5	=	045
0.25	=	Z25	0.9	=	J09	1.8	=	J18	3.0	=	030	4.7	=	047
0.3	=	J03	1.0	=	J10	1.9	=	J19	3.2	=	032	5.0	=	050
0.35	=	Z35	1.1	=	J11	2.0	=	J20	3.5	=	035	5.2	=	052
0.4	=	J04	1.2	=	J12	2.1	=	J21	3.7	=	037	5.5	=	055
0.45	=	Z45	1.3	=	J13	2.2	=	J22	3.8	=	038	5.7	=	057
												8.5	=	085
												13.0	=	130
												20.0	=	200

T	A	4	5	-	A	B	L	T	F	2	0	0	U	2	-	7	0	1
					1	2 3		4		5		6*						

Undervoltage release 5

Rated voltage	Undervoltage release			No special feature
AC (V)	U1	E1	Z1	C0
400		E2	Z2	
240		E3	Z3	
230			Z4	
120				
AC/DC (V)			Z6	
48			Z7	
24			Z8	
12				

* Schematic drawings: 1-pole protected version shown only

Special marking	6	
Standard	=	(empty)
Special marking (XXX = placeholder)	=	XXX

Accessories

Description



TA45-ACC
 Accessories to TA45