

Specifications

Drawing No.	UKY1C-H1-25762-00[43]	1/11
Issued Date.	Jul.28,2025	

TO:

Note: Part numbers may be revised in the event of any specifications change.

Product Type	Quartz Crystal
Series	ST3215FB
Frequency	32.768 kHz
Customer Part Number	-
Customer Specification Number	-
KYOCERA Part Number	ST3215FB32768B0HPWH1
Remarks	Pb-Free, RoHS Compliant, MSL 1

Customer Approval

Approval Signature	Approved Date	
	Department	
	Person in charge	

Seller

KYOCERA Corporation

Corporate Electronic Components Group
 Electronic Components Sales Division
 6 Takeda Tobadono-cho, Fushimi-ku, Kyoto
 612-8501 Japan
 TEL. No. 075-604-3500
 FAX. No. 075-604-3501

Manufacturer

Corporate Electronic Components Group
 Electronic Devices Division

Design Department	Quality Assurance	Approved by	Checked by	Issued by
KYOCERA Corporation Crystal Components Application Engineering Section 2 Electronic Devices Division Corporate Electronic Components Group	A. Ito	T. Nitobe	S. Uchida	Y. Kikuchi 

Revision History

Rev.No.	Description of revision	Date	Approved by	Checked by	Issued by
00	First Edition	Jul.28,2025	T. Nitobe	S. Uchida	Y. Kikuchi

ATTENTION

[1] If you intend to use products on the controlling equipment that relate to medical, aeronautical, aerospace, military science, space and etc., please make sure to let us know your intentions in advance.

[2] Ultrasonic related process may cause damage to crystal blank by resonance itself. If ultrasonic related process is used, we strongly recommend to assess the damage risk under related ultrasonic conditions before use in production.

1. Electrical Specifications**1.1 General specification**

#	Parameter	Value/Description	Unit	Remark
1	Nominal frequency	32.768000	kHz	-
2	Cutting type	X-cut	-	-
3	Oscillation mode	Fundamental	-	-
4	Moisture sensitivity level (MSL)	Level 1	-	IPC/JEDEC J-STD-033C
5	ESD	2000V≤HBM<4000V	-	JESD22-A114-B

1.2 Operation conditions

#	Parameter	Min.	Typ.	Max.	Unit	Remark
1	Operating temperature	-40	-	+85	°C	-
2	Storage temperature	-55	-	+125	°C	-
3	Load capacitance (C _L)	-	6.0	-	pF	-
4	Drive level	-	0.5	1.0	μW	-

1.3 Frequency stability & electrical parameters

#	Parameter	Min.	Typ.	Max.	Unit	Remark
1	Initial frequency tolerance	-20	-	+20	ppm	At 25±3°C,DL=0.5uW
2	Turnover Temperature	20	25	30	°C	-
	Freq.vs Temp. Coefficient	-	-	-0.04	ppm/°C ²	
3	Frequency aging (First year)	-3	-	+3	ppm	At 25±3°C,DL=0.5uW
4	Equivalent series resistance (ESR)	-	-	70	k-ohms	-
5	Shunt capacitance (C ₀)	-	1.2	-	pF	-
6	Motional capacitance (C ₁)	-	4.3	-	fF	-
7	insulation resistance	500	-	-	M-ohms	At DC 100V ± 5V

Measure equipment: Electrical characteristics is measured by S&A 250B or equivalent.

Standard atmospheric conditions:

Unless otherwise specified, the standard environmental conditions for performance measurement and tests are under ambient temperature at +25±2°C and relative humidity: 40% to 70%.

2. Product Design

2.1 Package dimensions and pad functions

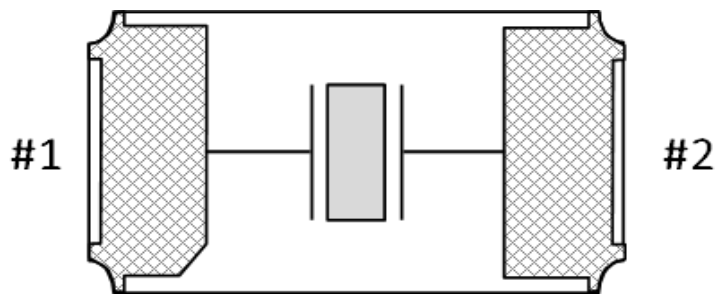
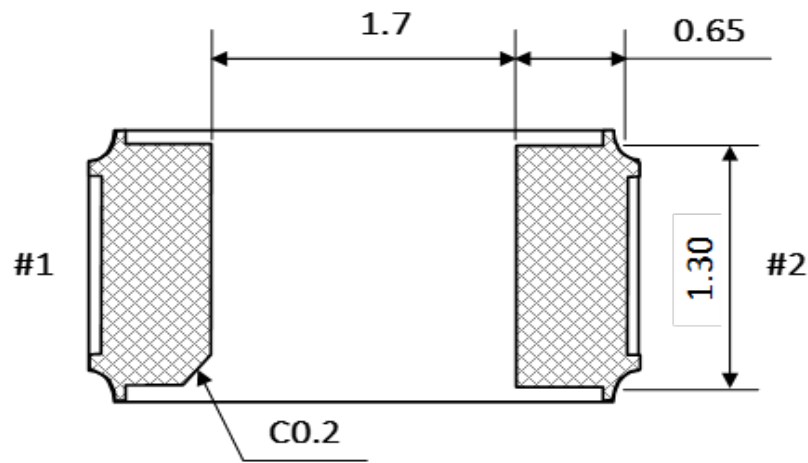
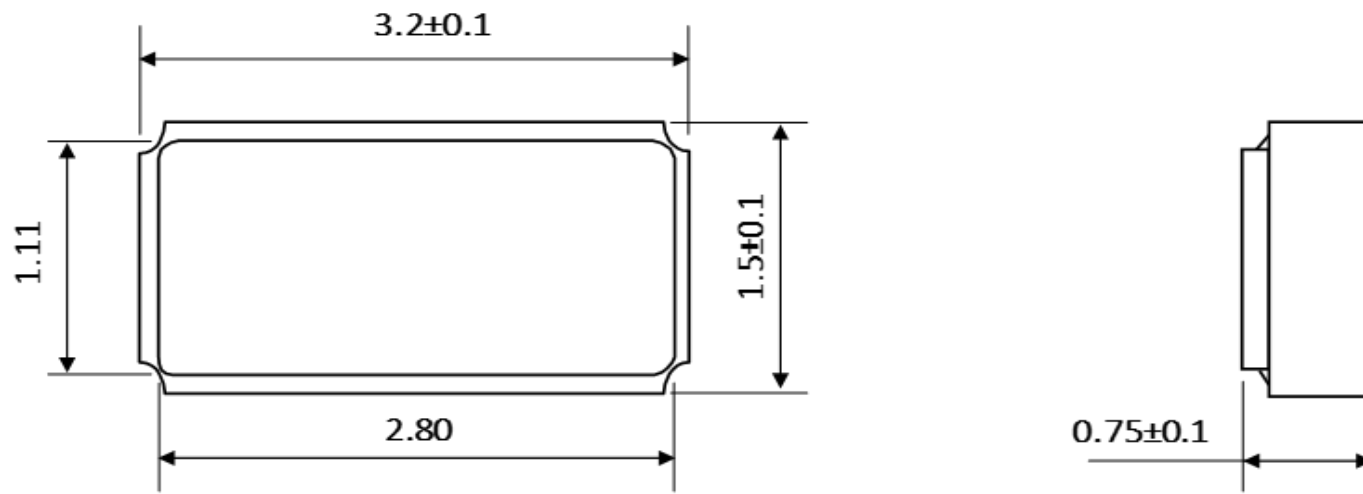

Unit : mm

Tolerance unless otherwise specified: ±0.15mm.

2.2 Recommended land pattern

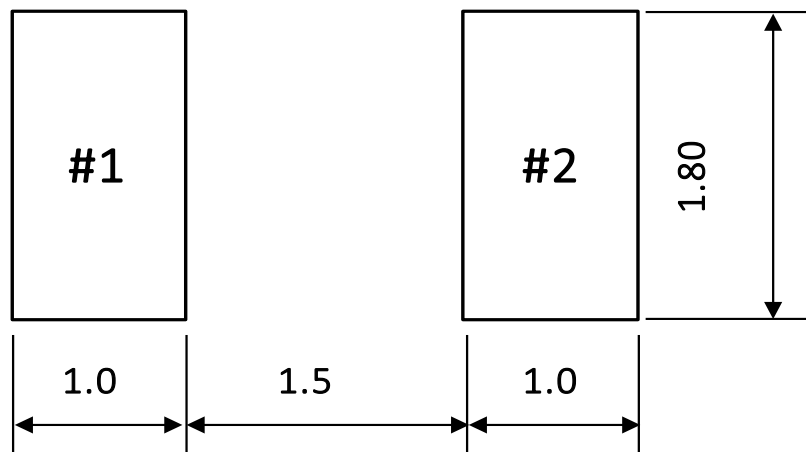

Unit : mm

Recommended reference dimension.

2. Product Design (Cont.)

2.3 Recommended reflow profile and manual soldering conditions

The recommended reflow soldering profile for SMT components is according to IPC/JEDEC J-STD-020.

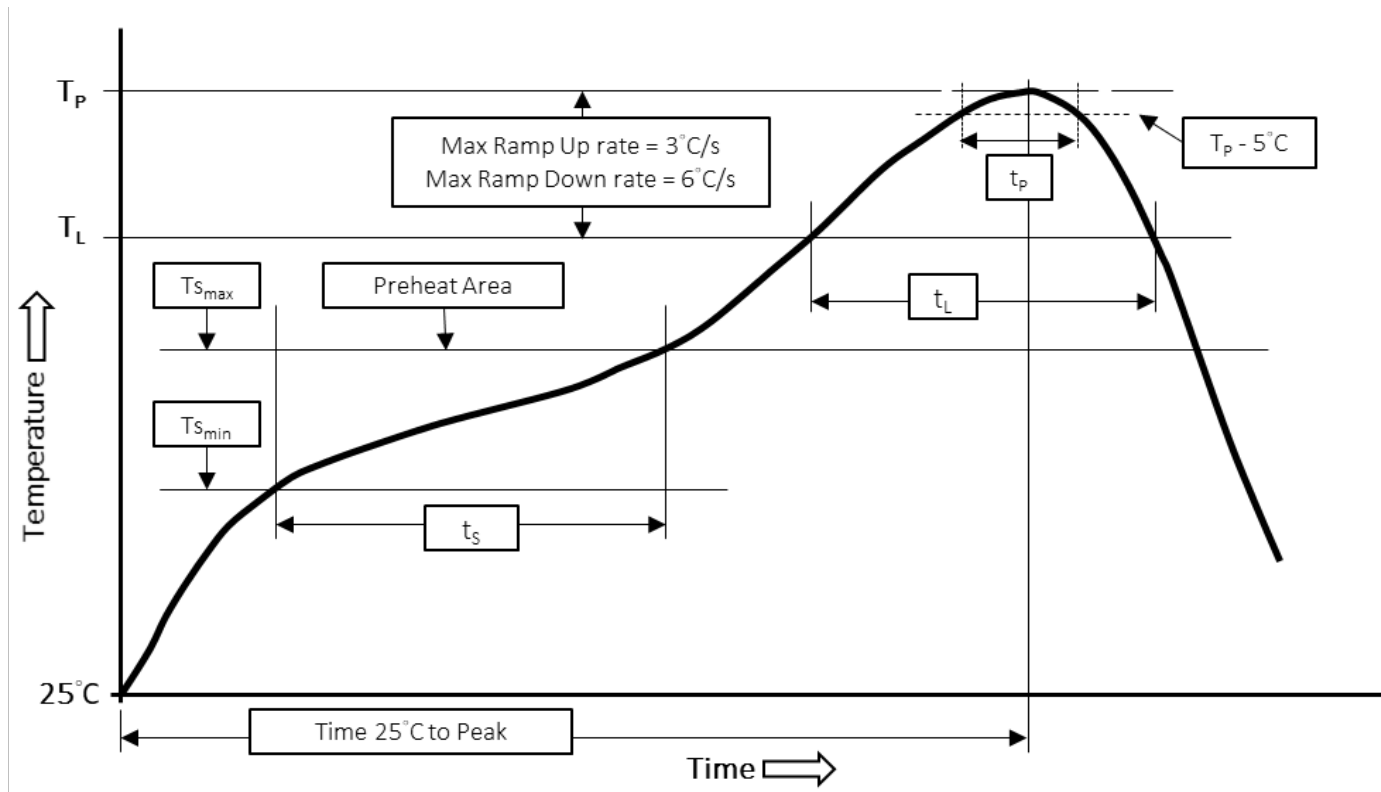

Profile Feature	Pb-free Assembly (SAC Alloys)
Preheat Soak Temperature Min ($T_{s_{min}}$) Temperature Max ($T_{s_{max}}$) Time ($T_{s_{min}}$ to $T_{s_{max}}$) (t_s)	150°C 200°C 60 seconds to 120 seconds
Ramp-up rate (T_L to T_P)	3°C/second max.
Time 25°C to Peak Temperature	8 minutes max.
Liquidus temperature (T_L) Time maintained above Liquidus temperature (t_L)	217°C 60 seconds to 150 seconds
Peak temperature (T_P)	260°C±5°C
Time (t_p) within 5°C of T_P	30 seconds max.
Ramp-down Rate (T_P to T_L)	6°C/second max.

2. Product Design (Cont.)

2.3 Recommended reflow profile and manual soldering conditions (Cont.)

Recommended manual soldering conditions:

Parameters	Conditions
Soldering iron temperature	350°C max.
Time	4 seconds max.
Re-solder times	Twice

2.4 Product storage conditions

- [1] Temperature: 15 to 35°C.
- [2] Humidity: 30 to 70% RH.
- [3] Time: within 18 months since manufacturing date.
- [4] Please store the products in a dry, clean, well-ventilated area and avoid direct sunlight exposure, heat, and vibration.

2.5 Illustration to product structure

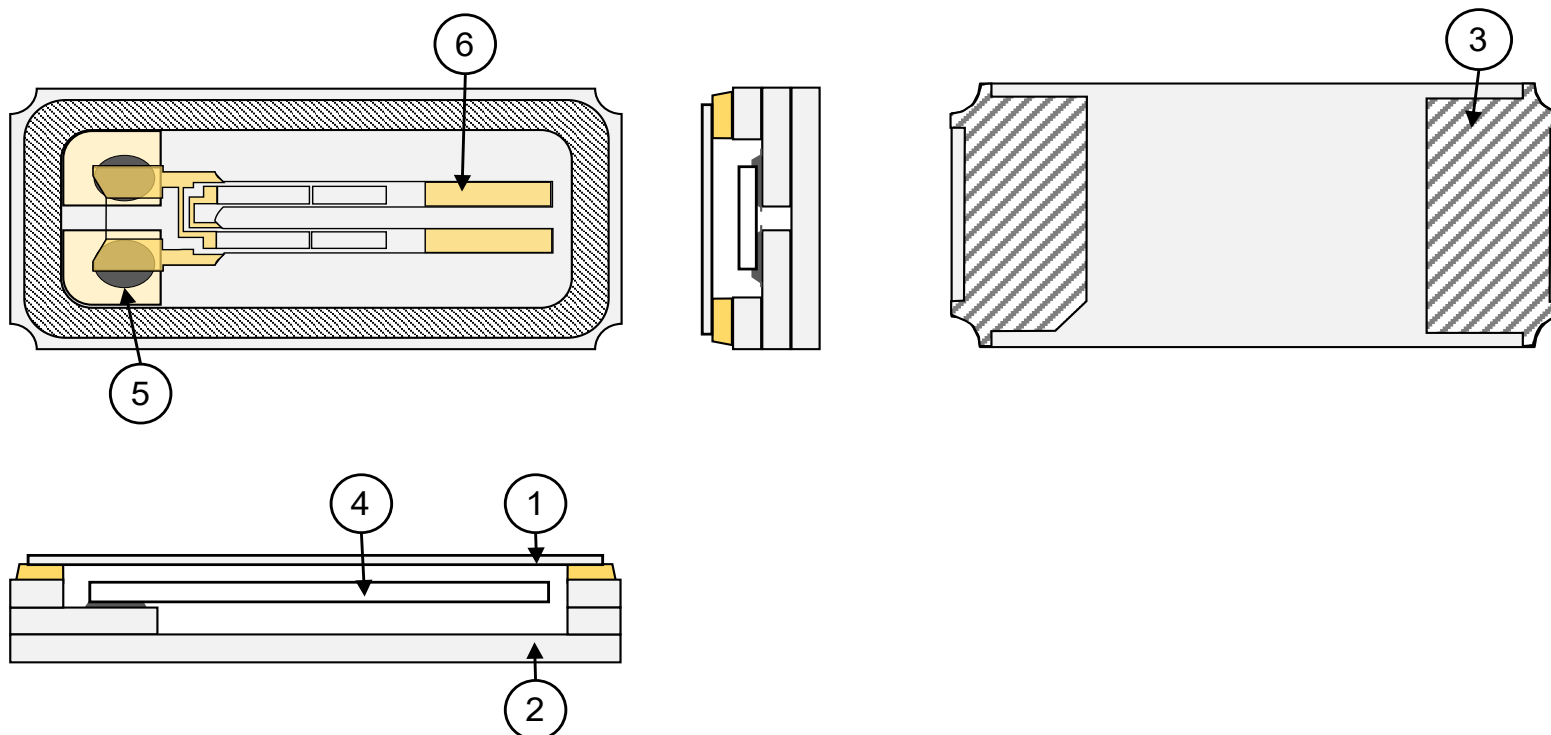

#	Components	Materials	QTY	Finish
1	Cap (Lid)	Kovar (Fe-Ni-Co)	1	Ni plating
2	Base (Package)	Almina ceramics (Al ₂ O ₃)	1	-
3	Pad (Package)	Ni + Au	2	Ni + Au plating
4	Crystal blank	SiO ₂	1	-
5	Conductive adhesive	Ag	2	Silicone resin
6	Electrode	Cr + Au	2	-

3. Reliability

3.1 Mechanical endurance

#	Item	Test Condition	Reference
1	Drop test	Measure after 100g-dummy drop from 1500mm height on the concrete 3directions 10times. *3	-
2	Vibration	Frequency range: 10 to 500 Hz Amplitude total: 0.75mm (10~55Hz) 98m/s ² (55~500Hz) Test time of each perpendicular axis: 2 hours (x, y, z axis) Total test time: 6 hours *3	MIL-STD-202 Method 201
3	Shear strength	Pressuring force: 20 N Test time: 10±1 sec.	IEC 60068-2-21
4	Bending test	Bending: 3 mm Thickness of the testing board: 1 mm Test time: 5±1 sec.	IEC 60068-2-21
5	Solderability	Temperature: 235°C ± 5 °C Immersing depth: 0.5 mm minimum Immersion time: 5 ± 1 sec. Flux: Rosin resin methyl alcohol solvent (1 : 4)	J-STD-002

3. Reliability (Cont.)

3.2 Environmental endurance

#	Item	Test Condition	Reference
1	High temperature storage	+125°C ± 3°C for 1000 hours *1,*2	MIL-STD-202 Method 108
2	High temperature storage	85°C ± 3°C for 1000 hours *1,*2	MIL-STD-202 Method 108
3	Low temperature storage	-55°C ± 3°C for 1000 hours *1,*2	IEC 60068-2-1
4	Thermal shock	Total 100 cycles of the following temperature cycle *1,*2 	IEC 60068-2-14
5	High temperature & humidity	+85°C ±3°C, RH 85%,for 1000 hours *1,*2	MIL-STD-202 Method 103
6	AIR Reflow	Refer to reflow profile on page 6 *2 Test time : 3 times	IPC/JEDEC J-STD-020.

Note:

1. Each test shall be done independently. (not in series tests)
2. *1: Pre conditions
 - (1)AIR Reflow : 2 times
 - (2) Initial values shall be measured after 24 hours at room temperature.
3. *2:Measure after 24 hours left at room temperature following the test.
4. *3:Measure after 2 hours left at room temperature following the test.

4. Marking and Packing(Cont.)

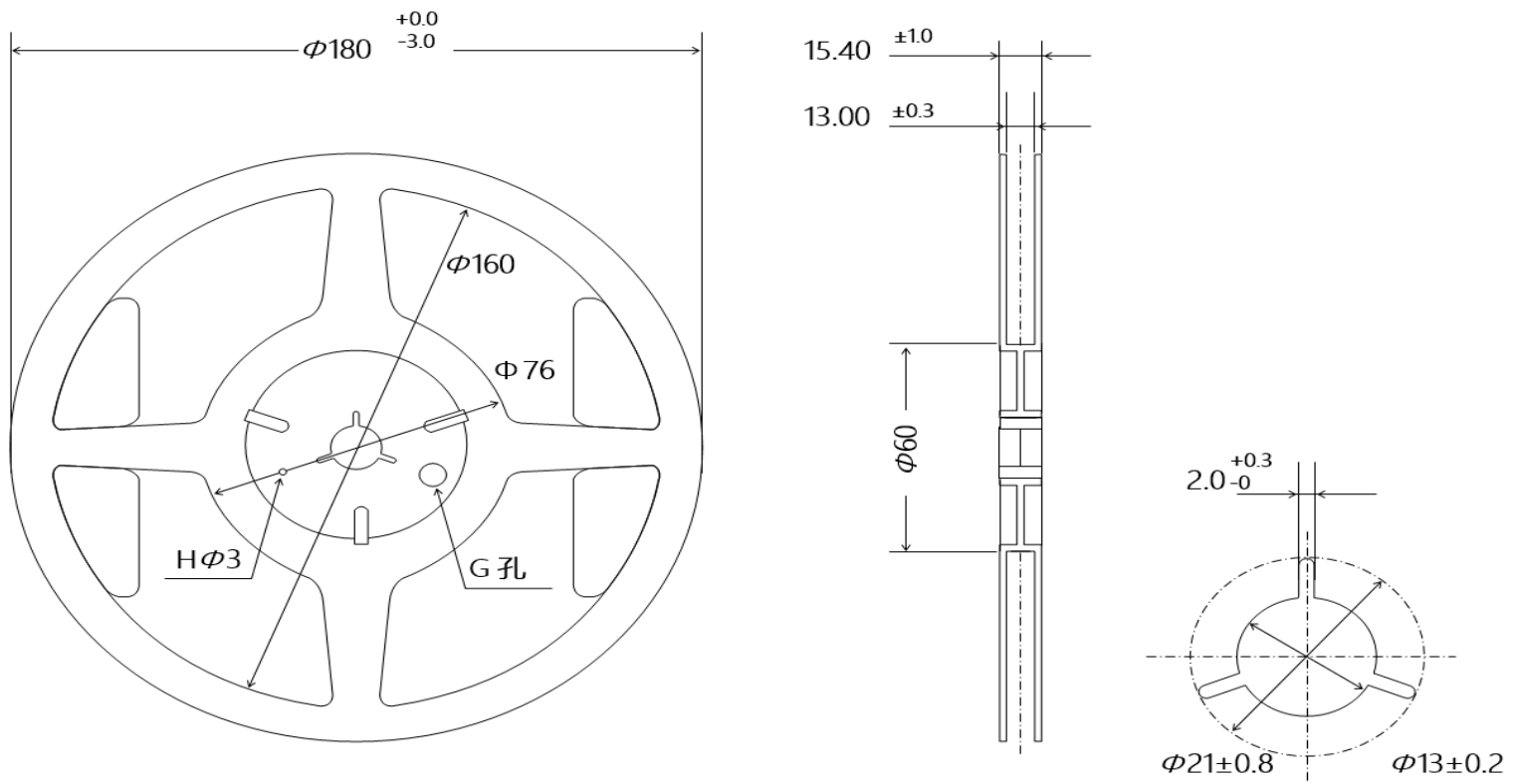
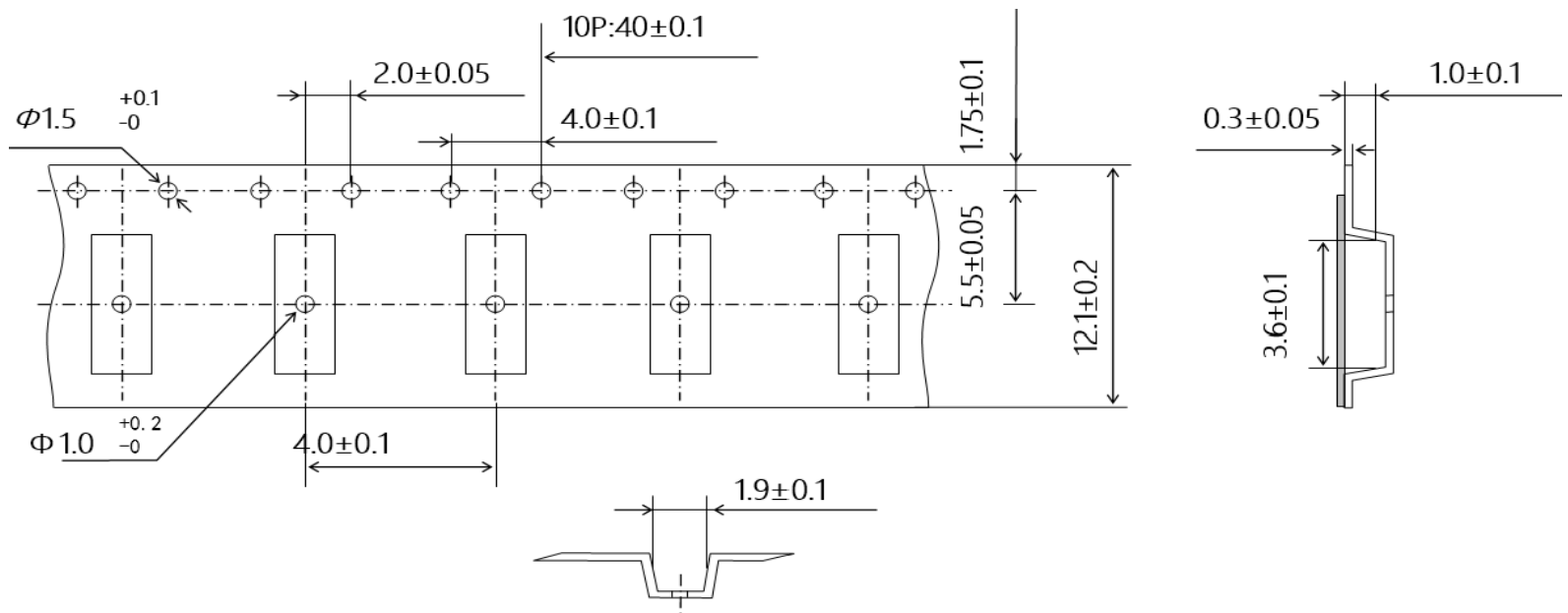

Item	Specification	Unit
Materials	PS (anti statics)	-
inside reel wise W1	13.0 ± 0.3	mm
outside reel wise W2	15.4 ± 1.0	mm

5. Quality Assurance

To be guaranteed by Kyocera Corporation Quality Assurance Division

6. Quality guarantee

In case when Kyocera Corporation rooted failure occurred within 1year after its delivery, substitute product will be arranged based on discussion. Quality guarantee of product after 1year of its delivery is waived.

7. Others

In case of any questions or opinions regarding the Specification, please have it in written manner within 45 days after issued date.

If you do not contact us within the deadline, we will assume that the items listed are approved.