



TAOGLAS®



Datasheet

Part No:
PC4212.07.0065A.by

Description

Low Profile Cellular Antenna 700-3000MHz 42 x 12 x 0.8 mm with 65 mm 1.13 and CM Micro RF I (MHFI Compatible) and AD tape

Features:

Coverage: 700-3000MHz
Dims: 42.5 x 12.5 x 1.05 mm
Cable: 65 mm of 1.13 Coaxial Cable
Connector: CM Micro RF I (MHFI Compatible)
RoHS & Reach Compliant



1.	Introduction	3
2.	Specification	4
3.	Mechanical Drawing	6
4.	Packaging	7
5.	Antenna Characteristics	8
6.	Radiation Patterns	12
<hr/>		
	Changelog	17

Taoglas makes no warranties based on the accuracy or completeness of the contents of this document and reserves the right to make changes to specifications and product descriptions at any time without notice. Taoglas reserves all rights to this document and the information contained herein. Reproduction, use or disclosure to third parties without express permission is strictly prohibited.

Ireland & USA
ISO 9001:2015
Certified



Taiwan
ISO 9001:2015
Certified



1. Introduction



The Taoglas PC4212 is a high-performance, low profile, PCB antenna designed to cover all working frequencies between 700-3000MHz. It is engineered to cover the 4G/3G cellular bands and the NB-IoT and Cat-M bands. With its super small footprint of just 42.5 x 12.5 mm, it alleviates size constraint issues commonly seen when integrating a high-performance antenna into compact IoT devices.

The antenna is delivered on a flexible PCB with exceptional efficiencies on all bands for antenna of this size. It is ground-plane independent, with a CM Micro RF I (MHFI Compatible) and 65 mm of 1.13 cable as standard for easy installation. It is made of durable flexible polymer, with efficiencies of up to 75% across the relevant cellular bands. At 42.5 x 12.5 x 1.05 mm, the antenna has a small footprint and is ultra-thin. It is installed in devices by a simple “peel and stick” process, attaching securely to non-metal surfaces via FT 7215L adhesive.

Typical Applications Include:

- IoT and Connected Devices
- Telematics and Fleet Management
- Remote Monitoring and Control Systems
- Drones and UAVs
- Mobile Devices and Tablets
- Smart Cities and Infrastructure

For more information on how to integrate the PC4212 into your device, contact your local Taoglas Customer Support Team.

2. Specification

LTE Electrical								
Band	Frequency (MHz)	Efficiency (%)	Average Gain (dB)	Peak Gain (dBi)	Impedance	Polarization	Radiation Pattern	Max. input power
4G/3G Band 12,13,14,17,28,29	700-806	38.4	-4.16	1.67	50 Ω	Linear	Omni	10W
4G/3G/NB-IoT/Cat M Band 5,8,18,19,20,26,27	824-960	59.5	-2.25	5.18				
4G/3G Band 1,2,3,4,9,23,25,35,39,66	1710-2200	77.6	-1.10	5.01				
4G/3G Band 7,30,38,40,41	2300-2690	63.0	-2.01	2.56				

Mechanical	
Dimensions	42.5 x 12.5 x 1.05 mm
Weight	1g
Material	FR4
Connector	MHF I
Cable	65 mm of 1.13 Coaxial

Environmental	
Operation Temperature	-40°C to 85°C
Storage Temperature	-40°C to 85°C
Relative Humidity	Non-condensing 65°C 95% RH

5G/4G Bands			
Band Number	5GNR / FR1 / LTE / LTE-Advanced / WCDMA / HSPA / HSPA+ / TD-SCDMA / NTN		
	Uplink	Downlink	Covered
B1	1920 to 1980	2110 to 2170	✓
B2	1850 to 1910	1930 to 1990	✓
B3	1710 to 1785	1805 to 1880	✓
B4	1710 to 1755	2110 to 2155	✓
B5	824 to 849	869 to 894	✓
B7	2500 to 2570	2620 to 2690	✓
B8	880 to 915	925 to 960	✓
B9*	1749.9 to 1784.9	1844.9 to 1879.9	✓
B11	1427.9 to 1447.9	1475.9 to 1495.9	*
B12	699 to 716	729 to 746	*
B13	777 to 787	746 to 756	✓
B14	788 to 798	758 to 768	✓
B17	704 to 716	734 to 746	✓
B18	815 to 830	860 to 875	✓
B19	830 to 845	875 to 890	✓
B20	832 to 862	791 to 821	✓
B21	1447.9 to 1462.9	1495.9 to 1510.9	*
B22*	3410 to 3490	3510 to 3590	*
B23 / n23	2000 to 2020	2180 to 2200	✓
B24 / n255	1626.5 to 1660.5	1525 to 1559	✓
B25	1850 to 1915	1930 to 1995	✓
B26	814 to 849	859 to 894	✓
B27*	807 to 824	852 to 869	✓
B28	703 to 748	758 to 803	✓
B29		717 to 728	✓
B30	2305 to 2315	2350 to 2360	✓
B31	452.5 to 457.5	462.5 to 467.5	*
B32		1452 to 1496	✓
B34		2010 to 2025	✓
B35		1850 to 1910	✓
B36		1930 to 1990	✓
B37		1910 to 1930	✓
B38		2570 to 2620	✓
B39		1880 to 1920	✓
B40		2300 to 2400	✓
B41		2496 to 2690	✓
B42		3400 to 3600	*
B43		3600 to 3800	*
B45		1447 to 1467	✓
B46		5150 to 5925	*
B47		5855 to 5925	*
B48		3550 to 3700	*
B49		3550 to 3700	*
B50		1432 to 1517	✓
B51		1427 to 1432	*
B52		3300 to 3400	*
B53		2483.5 to 2495	✓
B65	1920 to 2010	2110 to 2200	✓
B66	1710 to 1780	2110 to 2200	✓
B68	698 to 728	753 to 783	*
B69		2570 to 2620	✓
B70	1695 to 1710	1995 to 2020	✓
B71	663 to 698	617 to 652	*
B72	451 to 456	461 to 466	*
B73	450 to 455	460 to 465	*
B74	1427 to 1470	1475 to 1518	*
B75		1432 to 1517	✓
B76		1427 to 1432	*
B77		3300 to 4200	*
B78		3300 to 3800	*
B79		4400 to 5000	*
B85	698 to 716	728 to 746	*
B87	410 to 415	420 to 425	*
B88	412 to 417	422 to 427	*
n256	1980 to 2010	2170 to 2200	✓

3. Mechanical Drawing

ISO NO: EDW005206
 STATE: Release
 NOTES:

- All material must be RoHS compliant.
- Use this drawing together with the corresponding 3D CAD database file to fully describe the part.
- The connector orientation has a fixed position to the antenna as per drawing.
 * Critical Dimensions.

REV	ZONE	DESCRIPTION	ENG	APPROVED	DATE
002	All	PCB nesting colour change against EDW00465	Naht	Chozen	2025/10/28

CM Micro RF I Plug

	Name	Material	Finish	Qty
1	PCB	FR4	Black	1
2	L13 Coaxial Cable	PEP	Black	1
3	CM Micro RF I	Composite	Au Plated	1
4	Double sided adhesive	Avery Dennison FT 7215 0.151	White Liner (Avery Dennison logo)	1

APPROVED BY:	Chozen
CHECK BY:	Aaron
DRAWN BY:	Aaron
DATE:	05-01-2025
UNLESS OTHERWISE SPECIFIED DIMENSIONS IN	MM
THIRD ANGLE PROJECTION	

TAOGLAS. TV Design Centre

This drawing is the property of TAOGLAS. It is to be used for manufacturing purposes only and is not to be distributed outside the company.

TITLE: Low Profile Cellular Antenna 700-3000MHz 42x12x0.8mm with 65mm L13 and compatible with MHF I connector and AD tape

PART NO.: PC4212.07.0065A.by

UNIT: mm SCALE: 1:1 PAGES: 1/1 REV: D02

4. Packaging

100pcs PC4212.07.0065A.by per PE Bag
 Dimensions 180 x 100mm
 Weight - 88g



3000pcs PC4212.07.0065A.by per Large PE Bag
 Dimensions 300 x 160mm
 Weight - 2665g



30,000pcs PC4212.07.0065A.by per carton
 Dimensions 250 x 290 x 210mm
 Weight -26.7Kg

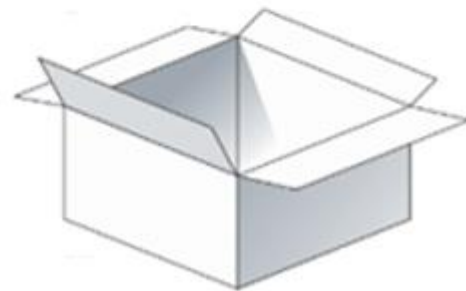

5. Antenna Characteristics

5.1 Test Setup

AUT



Vector Network Analyzer

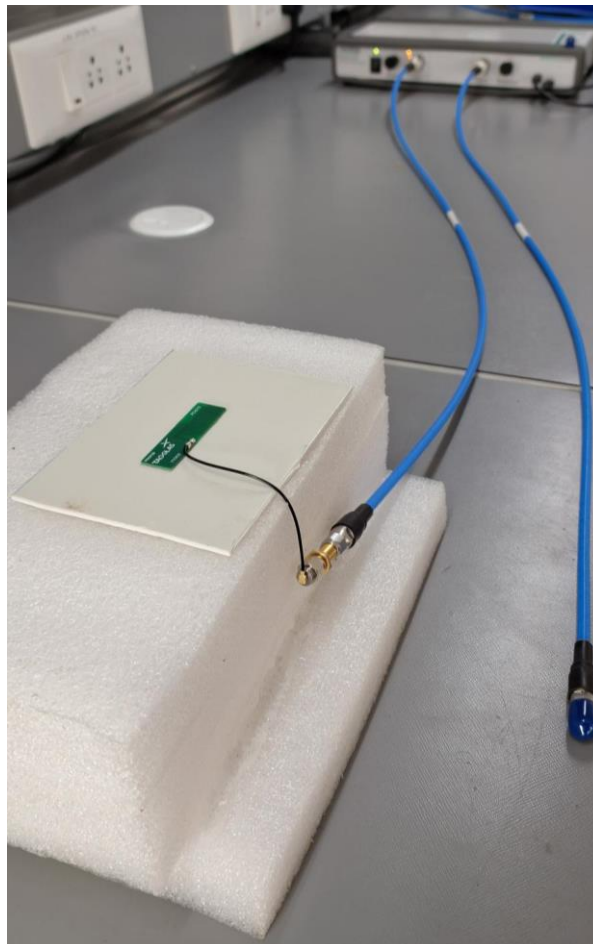

VNA Test Set-up on 2mm ABS

5.2 Return Loss

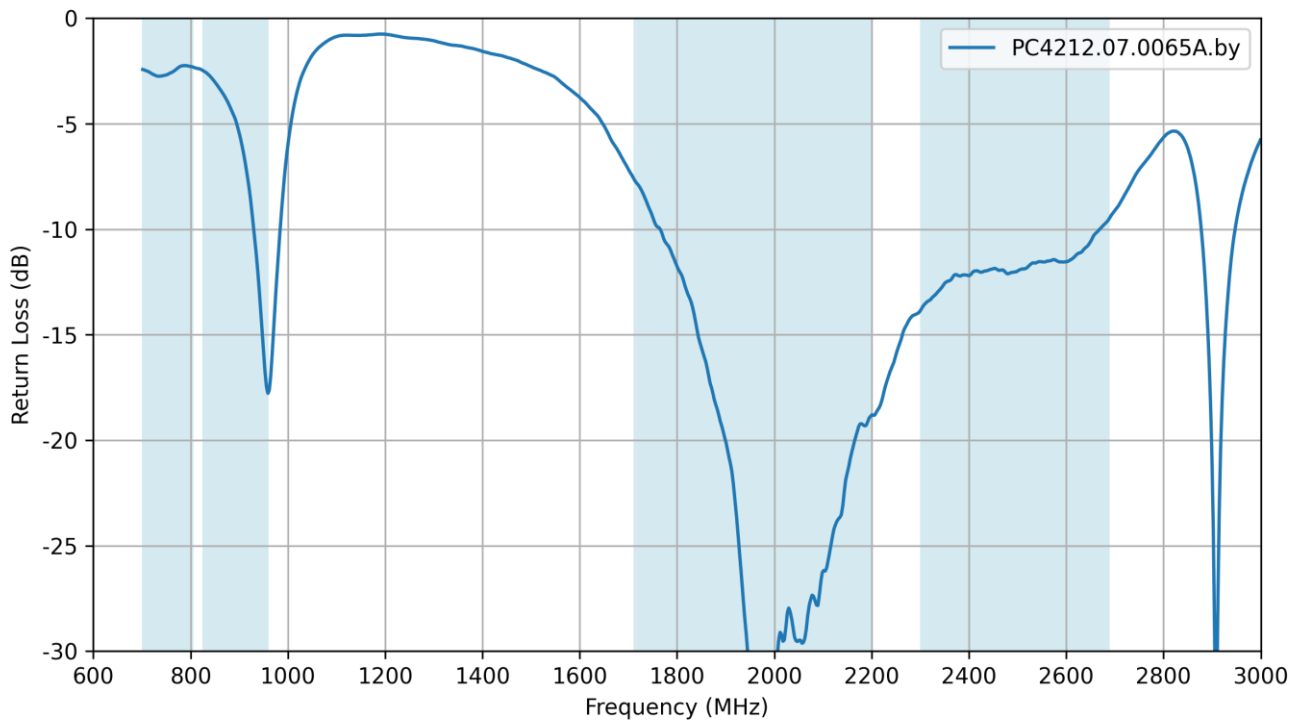

5.3 VSWR

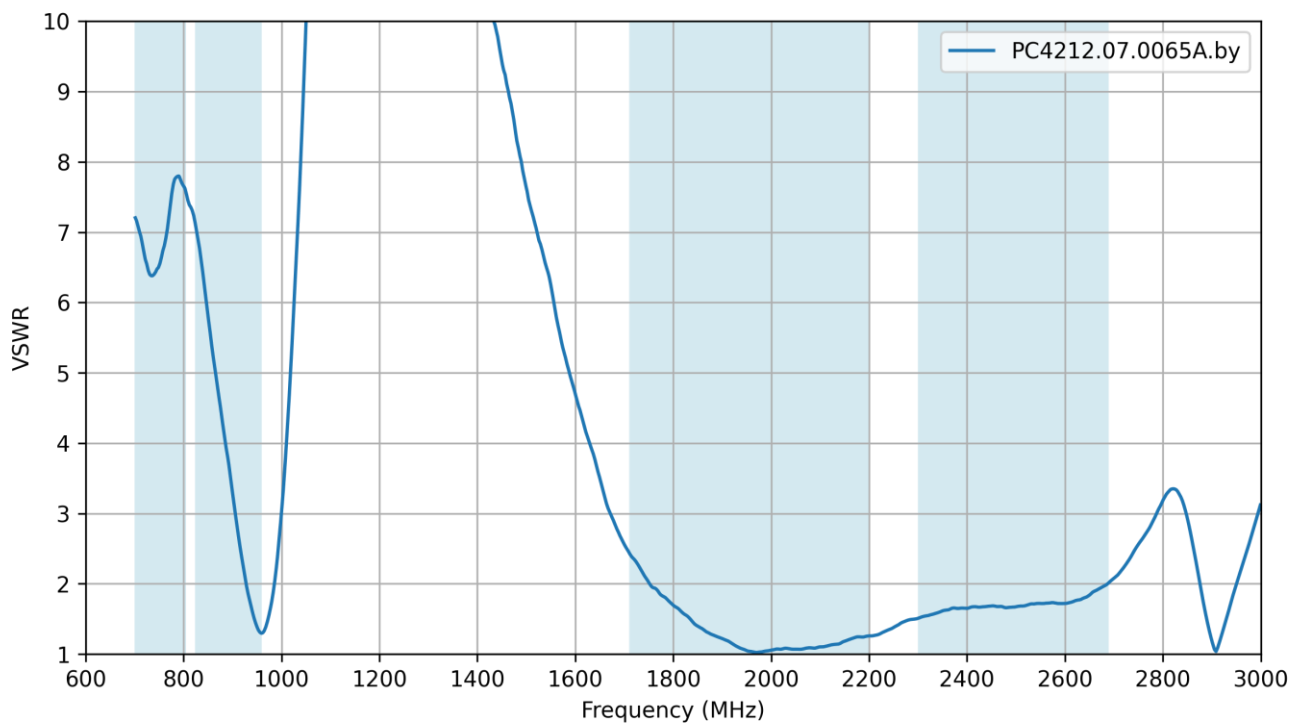

5.4 Efficiency

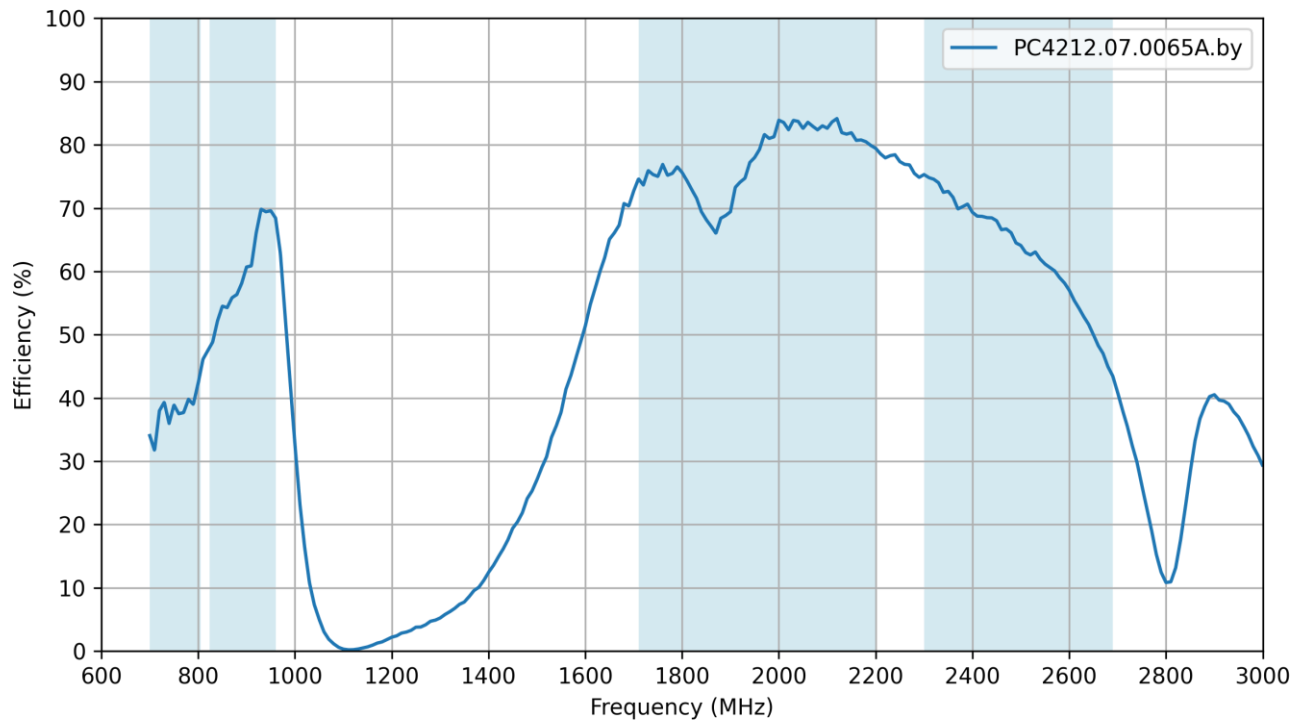

5.5 Average Gain

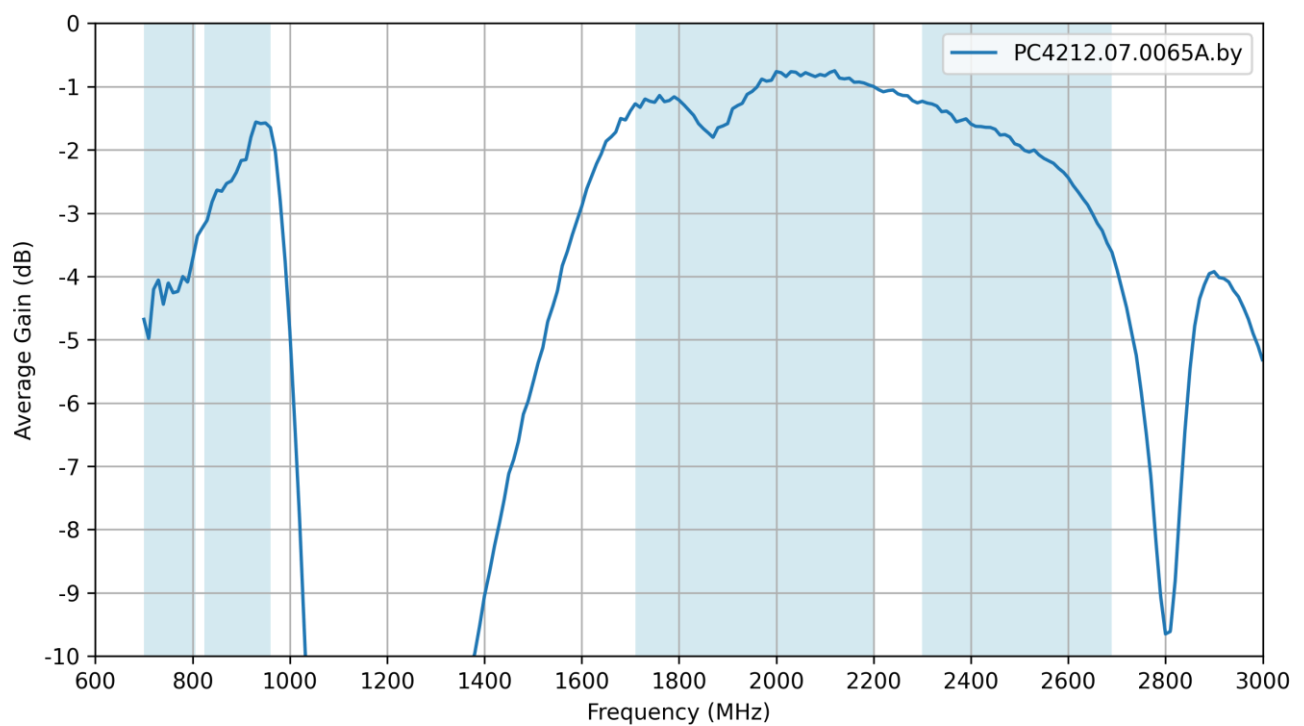

5.6 Peak Gain

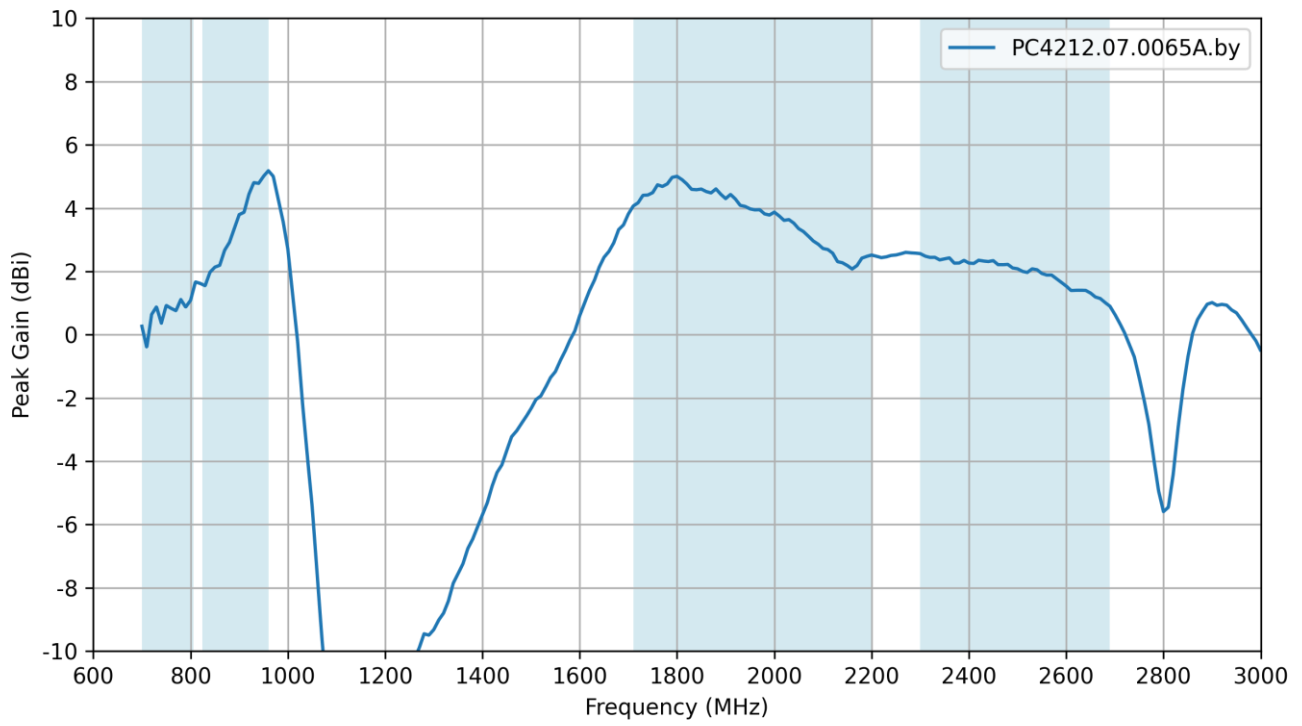

6. Radiation Patterns

6.1 Test Setup

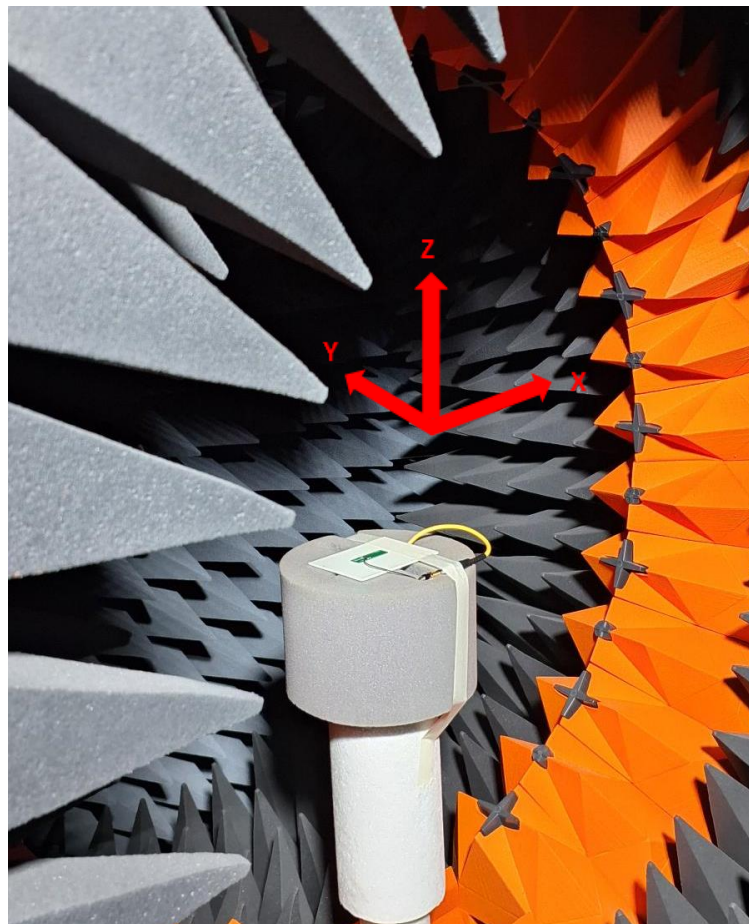
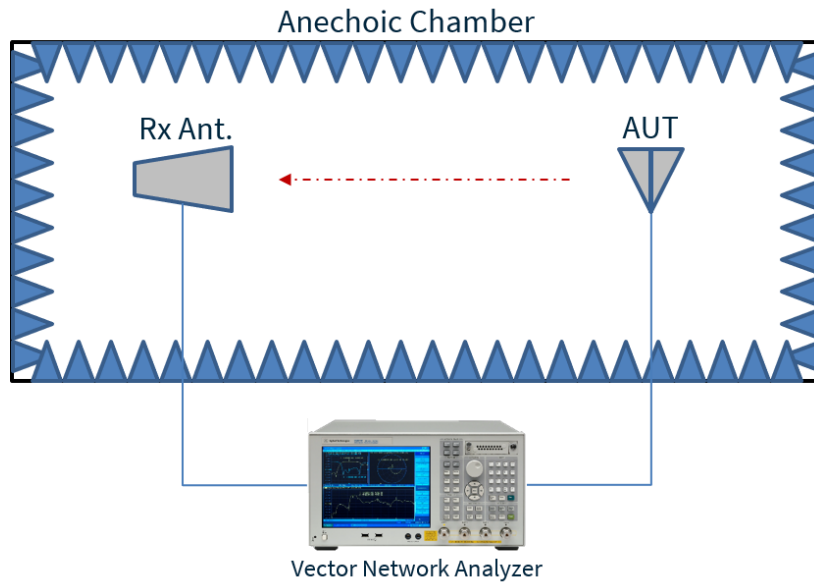

Chamber Test Set-up on 2mm ABS

6.2 Patterns at 750 MHz

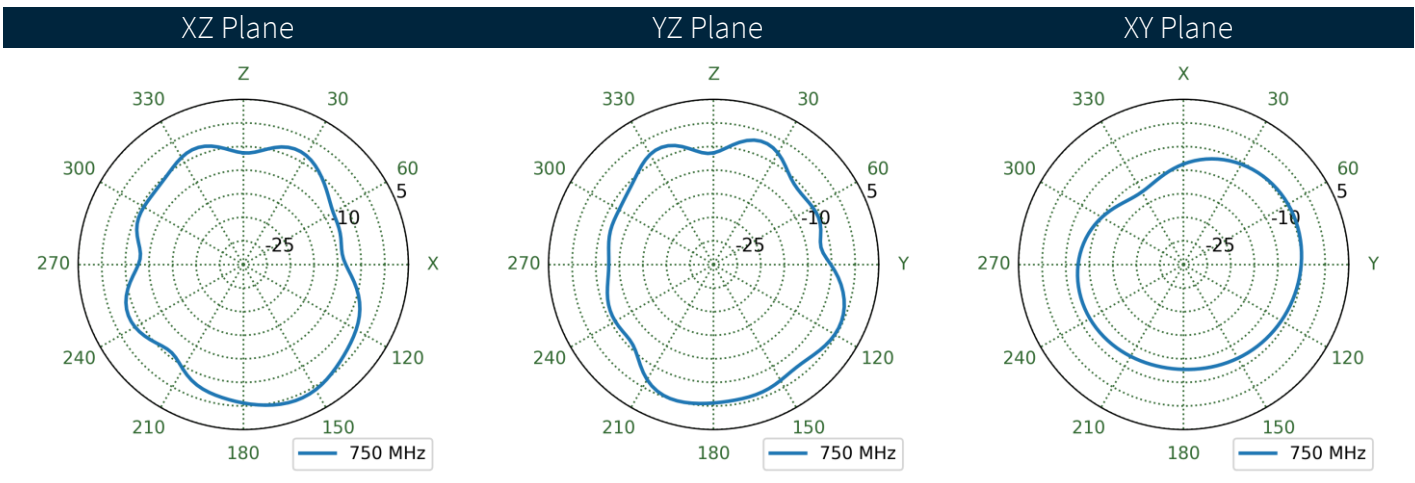
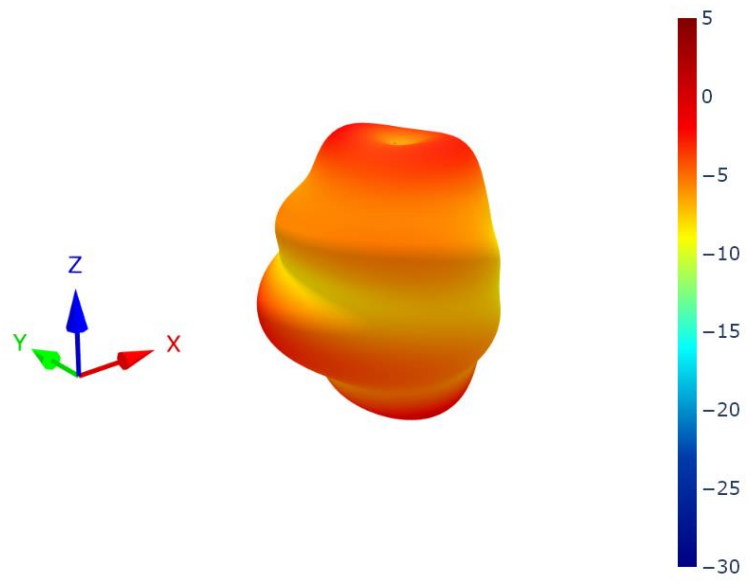

6.3 Patterns at 890 MHz

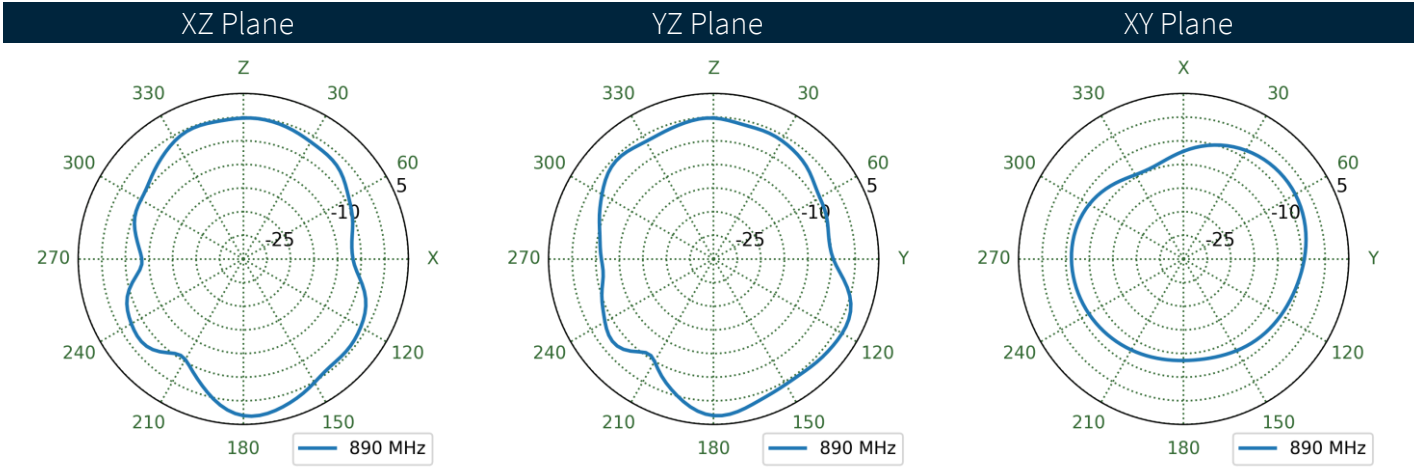
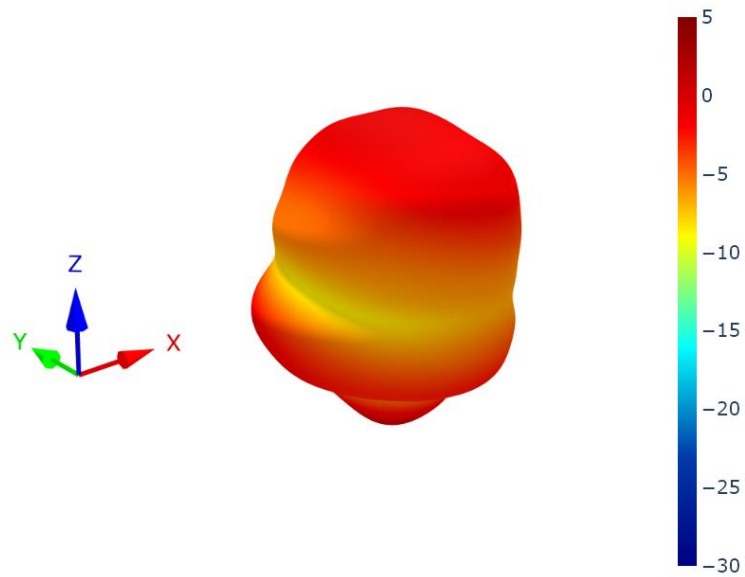

6.4 Patterns at 1950 MHz

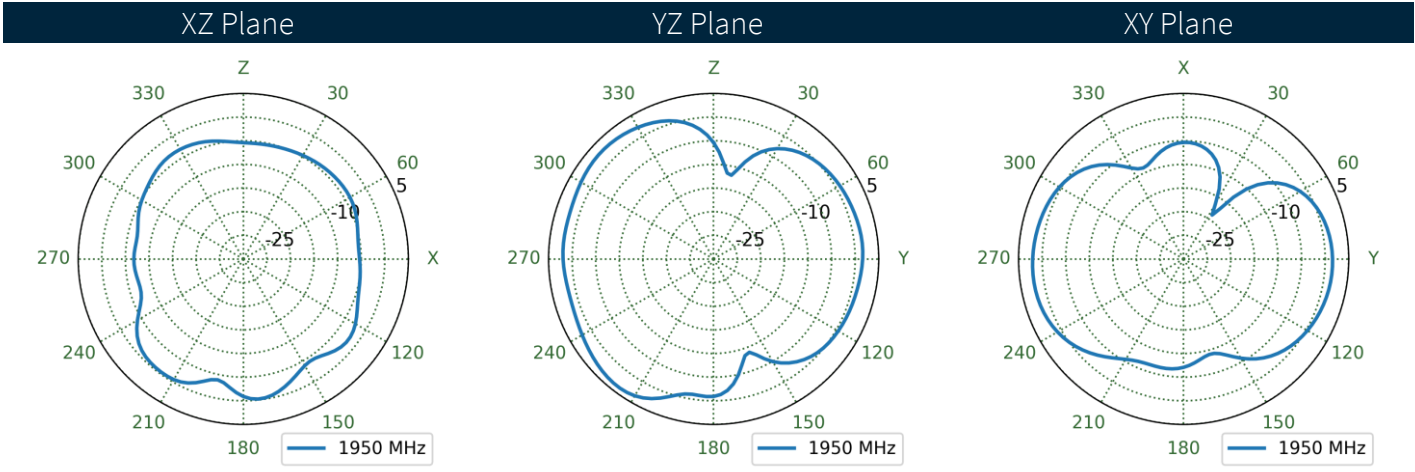
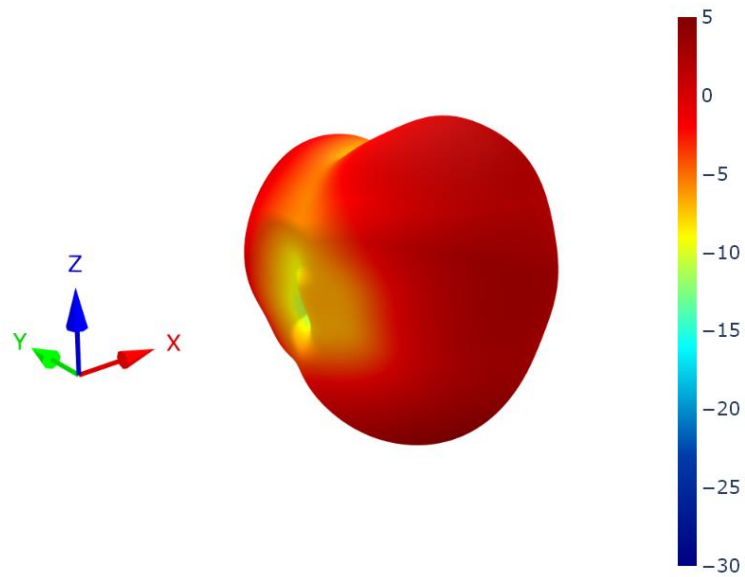

6.5 Patterns at 2490 MHz

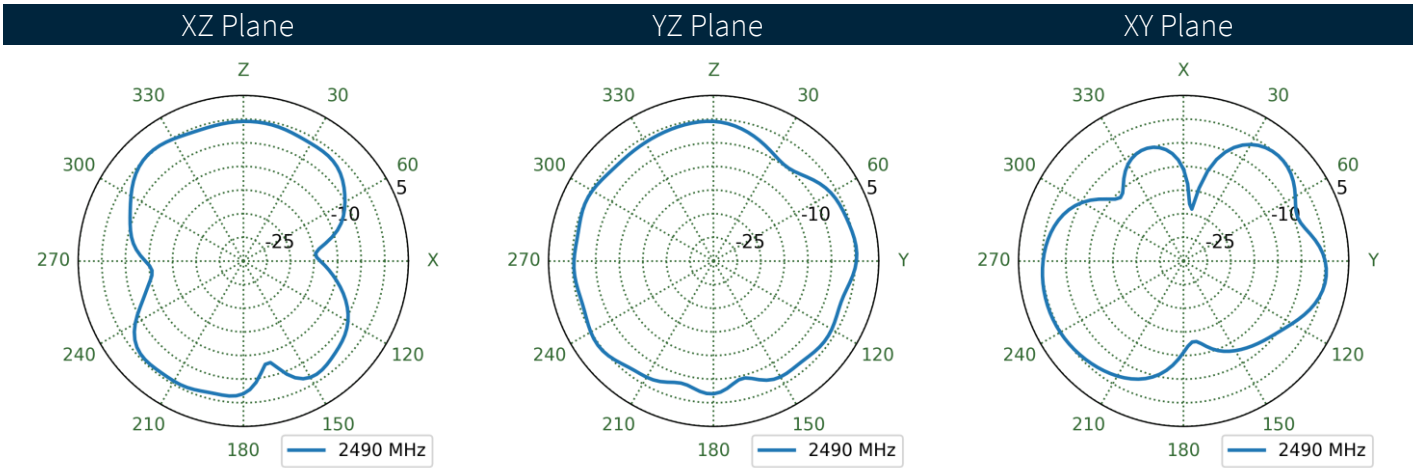
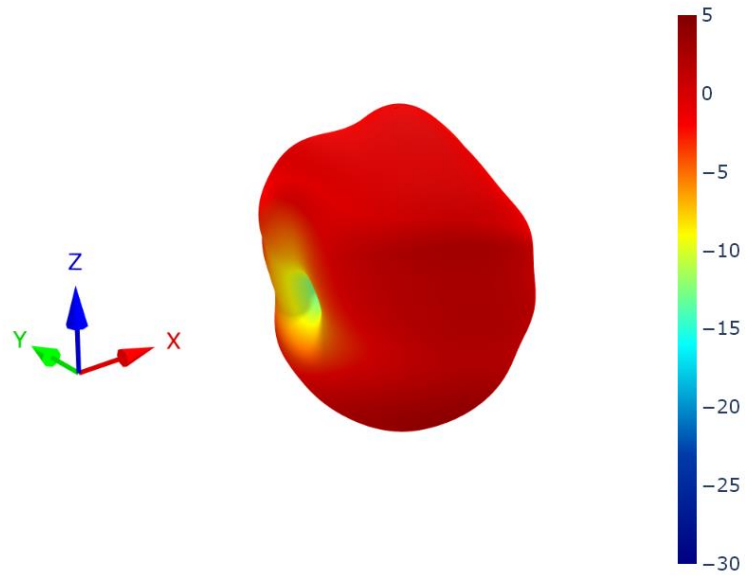

Changelog for the datasheet

SPE-25-8-033 – PC4212.07.0065A.by

Revision: A (Initial Release)	
Date:	2025-01-28
Notes:	Initial Datasheet Release
Author:	Gary West

Previous Revisions



www.taoglas.com

