

SERIES: PBO-5E | **DESCRIPTION:** AC-DC POWER SUPPLY

FEATURES

- small size, industrial design
- PCB SIP mounting
- universal input voltage range 85~305 Vac / 100~430 Vdc
- IEC/EN/UL 62368-1 certified
- designed to meet IEC/EN 61558 & IEC/EN 60335
- operating temperature -40°C ~ 85°C
- short-circuit, over current, and over voltage protection
- isolation voltage 4,000 Vac
- OVC III

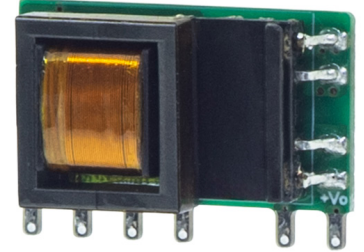

| MODEL | output voltage | output current | output power | ripple and noise ¹ | efficiency |
|-----------|----------------|----------------|--------------|-------------------------------|------------|
| | (Vdc) | max (mA) | max (W) | max (mVp-p) | typ (%) |
| PBO-5E-3 | 3.3 | 1,000 | 3.3 | 180 | 73 |
| PBO-5E-5 | 5 | 1,000 | 5.0 | 180 | 76 |
| PBO-5E-9 | 9 | 560 | 5.0 | 180 | 77 |
| PBO-5E-12 | 12 | 420 | 5.0 | 180 | 78 |
| PBO-5E-15 | 15 | 340 | 5.0 | 180 | 79 |
| PBO-5E-24 | 24 | 210 | 5.0 | 180 | 81 |

Notes: 1. 20 MHz bandwidth oscilloscope, 10% to full load, the output is in parallel with 10µF electrolytic capacitor and 1µF ceramic capacitor.
 2. For optimal performance, it is recommended to operate at a load of above 5%.
 If the load falls below 5%, the ripple index of the product may exceed specifications; however, this does not impact the product's reliability.
 3. All specifications are measured at Ta=25°C, humidity <75%, 115 or 230 Vac input voltage, and rated output load unless otherwise specified.

PART NUMBER KEY

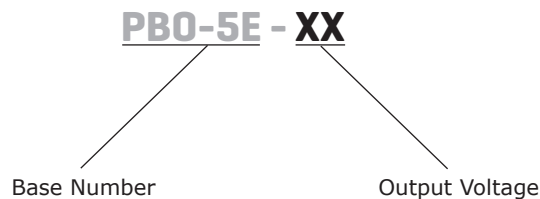

INPUT

| parameter | conditions/description | min | typ | max | units |
|---------------------------|-------------------------|-----|-------|------|-------|
| voltage ⁴ | ac input | 85 | | 305 | Vac |
| | dc input | 100 | | 430 | Vdc |
| frequency | | 47 | 50~60 | 63 | Hz |
| current | at 110 Vac | | | 0.15 | A |
| | at 230 Vac | | | 0.07 | A |
| fuse | 1A, slow-blow, required | | | | |
| no load power consumption | at 230 Vac | | 0.10 | | W |

Notes: 4. The input voltage must remain within the specified range to prevent potential permanent and irreparable damage.

OUTPUT

| parameter | conditions/description | min | typ | max | units |
|------------------------------|--|-----|-------|-------|-------|
| capacitive load ⁵ | 3.3, 5 Vdc output model | | | 1,500 | μF |
| | 9 Vdc output model | | | 680 | μF |
| | 12 Vdc output model | | | 470 | μF |
| | 15 Vdc output model | | | 330 | μF |
| | 24 Vdc output model | | | 100 | μF |
| initial set point accuracy | from 10~100% load | | ±5 | | % |
| line regulation | at rated load | | ±2.5 | | % |
| | 3.3 Vdc output model all other models | | ±1.5 | | % |
| load regulation | from 10~100% load | | ±3 | | % |
| temperature coefficient | | | ±0.15 | | %/°C |
| hold-up time | at 115 Vac | | 8 | | ms |
| | at 230 Vac | | 40 | | ms |

Notes: 5. The maximum capacitive load is tested within the input voltage range and under full load conditions.

PROTECTIONS

| parameter | conditions/description | min | typ | max | units |
|--------------------------|---------------------------|-----|-----|-----|-------|
| over current protection | | 110 | | | % |
| short circuit protection | continuous, auto recovery | | | | |

SAFETY & COMPLIANCE

| parameter | conditions/description | min | typ | max | units |
|---------------------|--|-----------|-----|-----|-------|
| isolation voltage | input to output for 1 minute, 5mA max | 4,000 | | | Vac |
| safety approvals | certified to 62368-1: IEC, EN, UL | | | | |
| | designed to meet 61558-1: IEC, EN | | | | |
| | designed to meet 60335-1: IEC, EN | | | | |
| safety class | Class II | | | | |
| conducted emissions | CISPR32/EN55032 CLASS A (see application circuit) | | | | |
| | CISPR32/EN55032 CLASS B (see EMC recommended circuit) | | | | |
| radiated emissions | CISPR32/EN55032 CLASS A (see application circuit) | | | | |
| | CISPR32/EN55032 CLASS B (see EMC recommended circuit) | | | | |
| ESD | IEC/EN61000-4-2 Contact ±6 kV / Air ±8 kV, perf. Criteria B | | | | |
| radiated immunity | IEC/EN61000-4-3 10 V/m, perf. Criteria A | | | | |
| EFT/burst | IEC/EN61000-4-4 ±2 kV, perf. Criteria B (see application circuit) | | | | |
| | IEC/EN61000-4-4 ±4 kV, perf. Criteria B (see EMC recommended circuit) | | | | |
| surge | IEC/EN61000-4-5 line to line ±1 kV, perf. Criteria B (see application circuit) | | | | |
| | IEC/EN61000-4-5 line to line ±2 kV, perf. Criteria B (see EMC recommended circuit) | | | | |
| conducted immunity | IEC/EN61000-4-6 10 Vrms, perf. Criteria A | | | | |
| MTBF | as per MIL-HDBK-217F at 25 °C | 1,000,000 | | | hours |
| RoHS | yes | | | | |

ENVIRONMENTAL

| parameter | conditions/description | min | typ | max | units |
|-----------------------|------------------------|-----|-----|-------|-------|
| operating temperature | see derating curves | -40 | | 85 | °C |
| storage temperature | | -40 | | 105 | °C |
| operating altitude | | | | 2,000 | m |

SOLDERABILITY

| parameter | conditions/description | min | typ | max | units |
|----------------|------------------------|-----|-----|-----|-------|
| wave soldering | for 5~10 seconds | 255 | 260 | 265 | °C |
| hand soldering | for 3~5 seconds | 355 | 360 | 365 | °C |

DERATING CURVES

TEMPERATURE DERATING CURVE

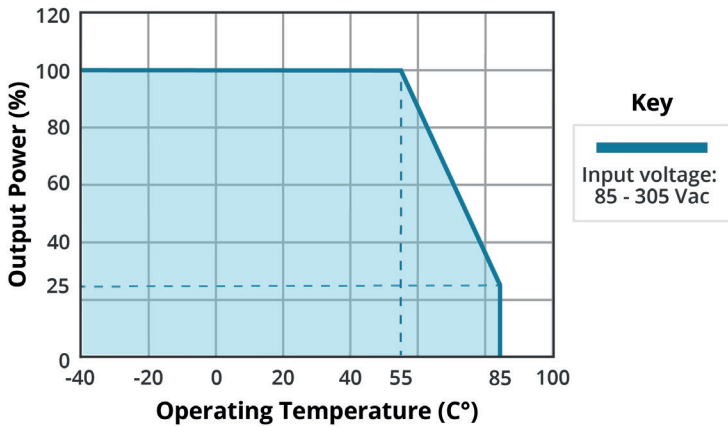

INPUT VOLTAGE DERATING CURVE (25°C)

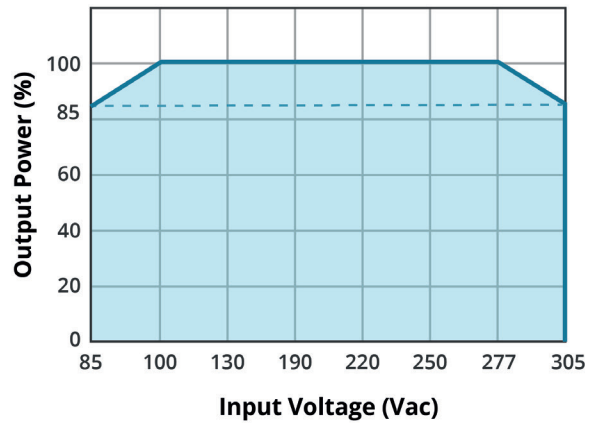

EFFICIENCY CURVES

EFFICIENCY VS INPUT VOLTAGE (full load)

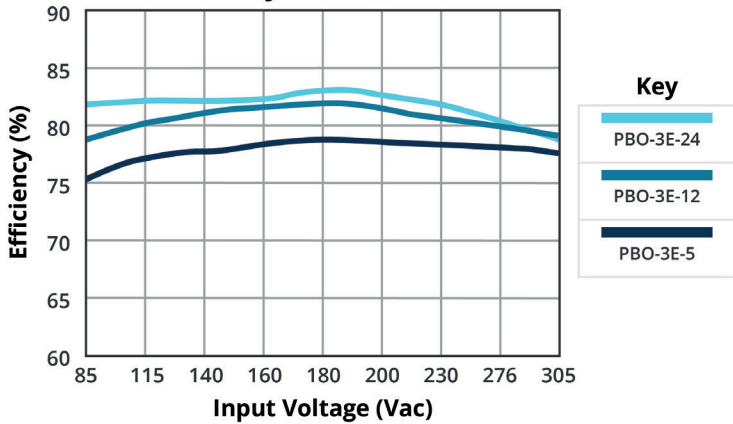

EFFICIENCY VS OUTPUT CURRENT (Vin = 230 Vac)

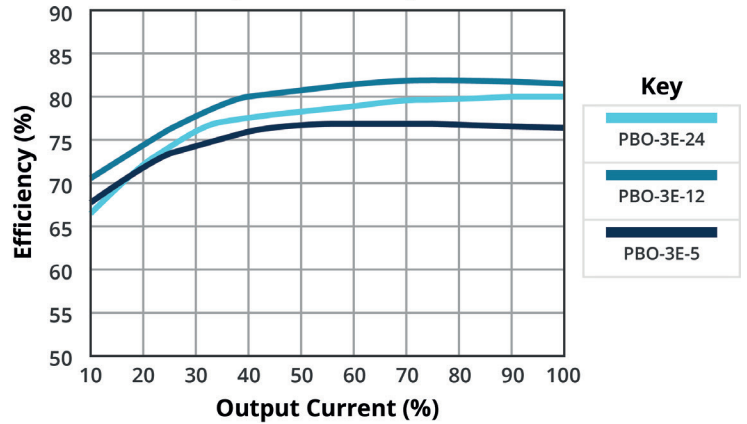

MECHANICAL

| parameter | conditions/description | min | typ | max | units |
|------------|--|-----|-----|-----|-------|
| dimensions | 26.40 x 17.60 x 11.00 [1.039 x 0.623 x 0.433 inch] | | | | mm |
| weight | | | 5.9 | | g |
| cooling | natural convection | | | | |

MECHANICAL DRAWING

units: mm [inch]
 pin section tolerance: $\pm 0.10[\pm 0.004]$
 tolerance: $\pm 0.50[\pm 0.020]$

| PIN CONNECTIONS | |
|-----------------|----------|
| PIN | Function |
| 1 | AC (L) |
| 2 | AC (N) |
| 3 | +V(CAP) |
| 4 | -V(CAP) |
| 5 | -Vo |
| 6 | +Vo |

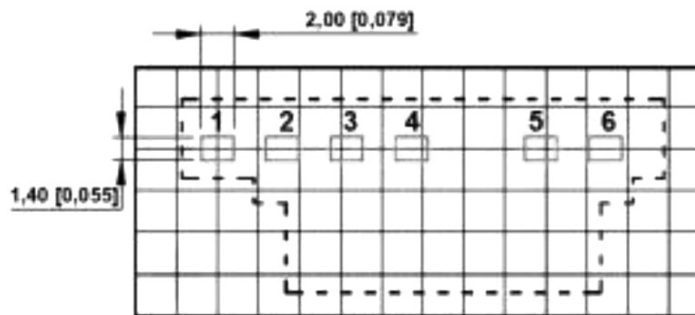
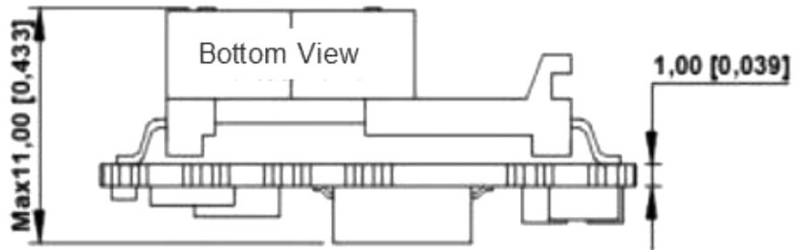
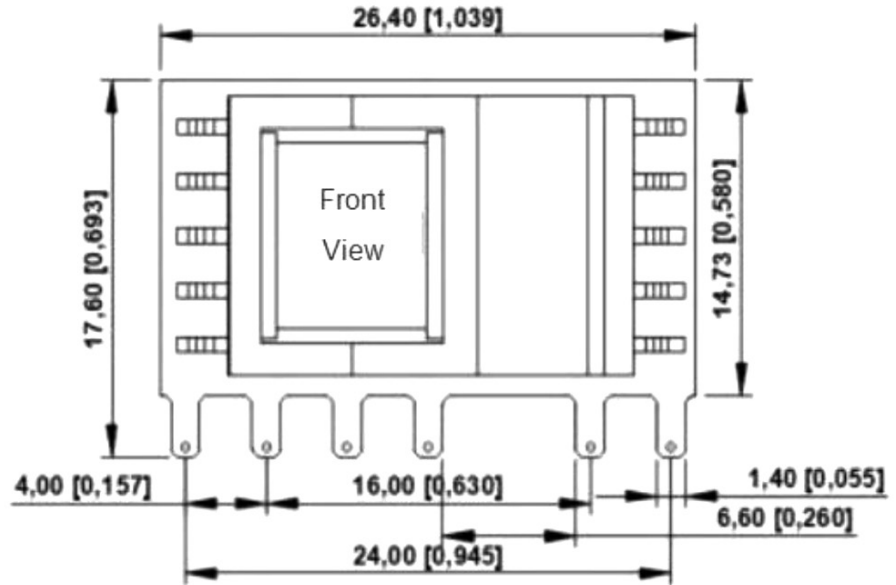

APPLICATION DESIGN REFERENCE

Figure 1

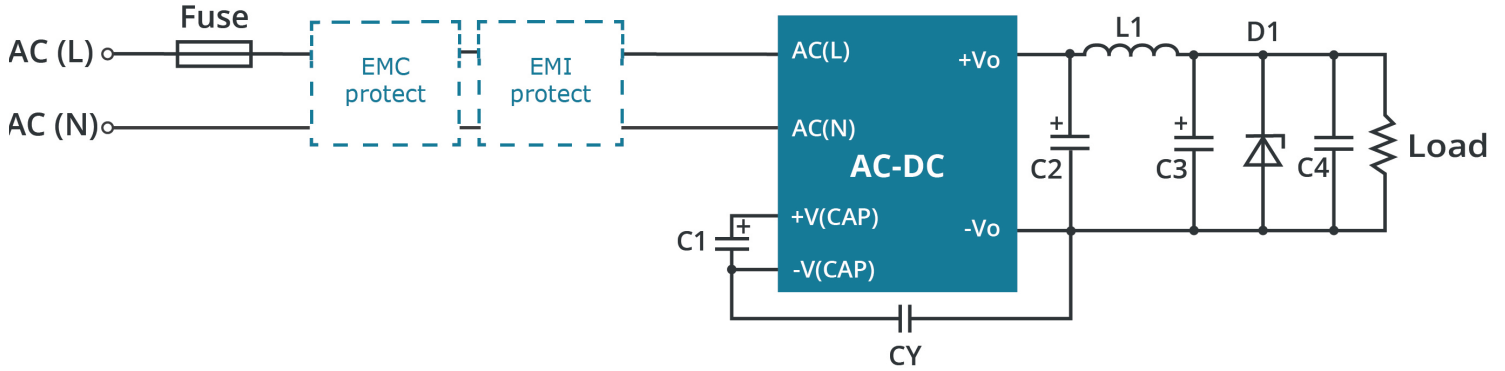

Table 1

| Additional component selection guide | | | | | | | |
|--------------------------------------|---------------|-----------------------------------|-----------------------|---------------|-----------|---------------|--|
| Vout | C1 (required) | C2 (required) | L1 (required) | C3 (required) | C4 | CY (required) | D1 |
| 5 | 10μF/450V | 560μF/16V (solid-state capacitor) | 2.2μH 3A 40 mΩ max | 100μF/16V | 0.1μF/50V | 1nF/400V | D1 is a TVS transistor that can protect the downstream circuit in case of module abnormalities. It is recommended to choose a model that is 1.2 times the output voltage |
| 12 | | 330μF/25V (solid-state capacitor) | | 100μF/25V | | | |
| 15, 24 | | 330μF/35V | 3.3μH 2A 40 mΩ max | 47μF/35V | | | |

- Note:
1. FUSE, EMC protection, and EMI protection are selected based on actual application needs.
 2. C1 is a filtering electrolytic capacitor, which is a required component. It is recommended to use ripple current > 400mA at 100KHz electrolytic capacitors.
 3. C2, C4, and L1 form a Pi type filtering circuit, and it is recommended to use high-frequency low resistance electrolytic capacitors or solid-state capacitors. When selecting L1, ripple requirements can be considered, while paying attention to current and internal resistance values.
 4. L1 selection can take into account the ripple requirements, while paying attention to current and internal resistance values.

Table 2

| Environmental and EMC selection guide | | | | | | |
|---------------------------------------|-------------------------------|--|---------------------|-------------------------|---------|-----------|
| Recommended circuit | Application environmental | Typical industry | Input voltage range | Environment temperature | EMI | EMS |
| 1 | Basic application | None | 85 ~ 305 Vac | -40° ~ 88°C | Class A | Class III |
| 2 | Indoor civil environment | Smart home / Home appliances | | -25° ~ 55°C | Class B | Class III |
| | Indoor general environment | Intelligent building / Intelligent agriculture | | -25° ~ 55°C | Class B | Class IV |
| 3 | Indoor industrial environment | Manufacturing workshop | | -40° ~ 85°C | Class A | Class IV |

APPLICATION DESIGN REFERENCE (CONTINUED)

Figure 2

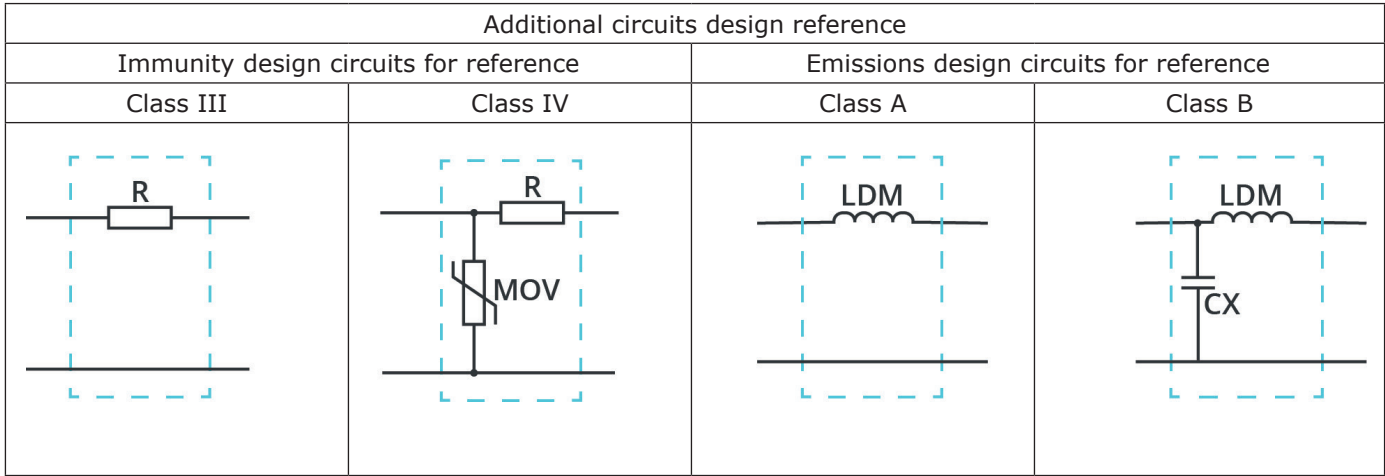

EMC RECOMMENDED CIRCUIT

Figure 3

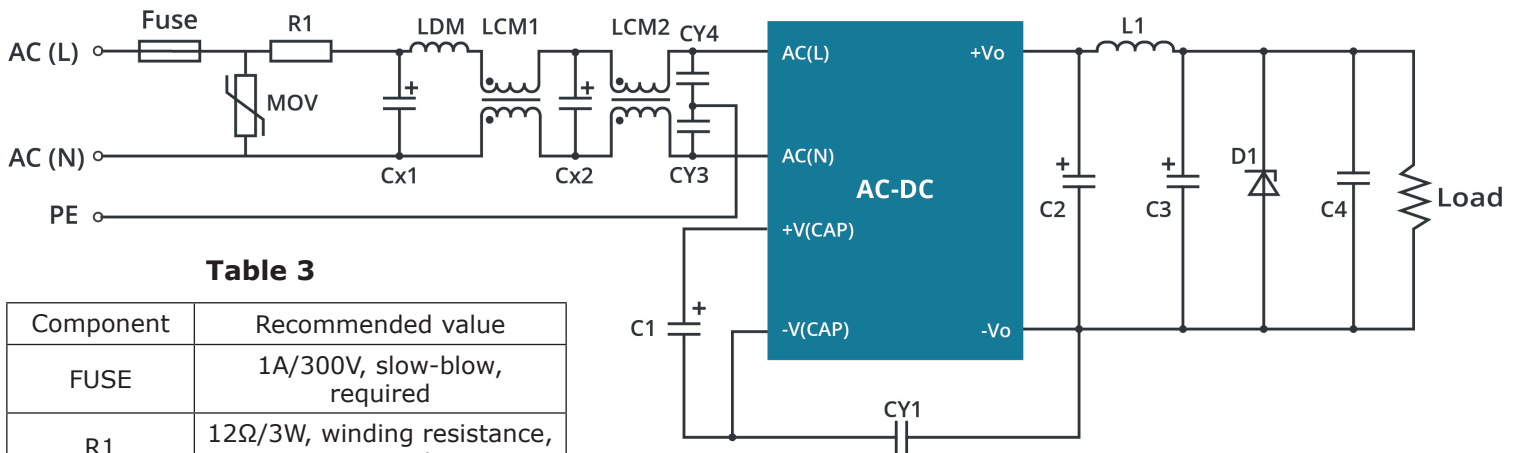

Table 3

| Component | Recommended value |
|-------------|---|
| FUSE | 1A/300V, slow-blow, required |
| R1 | 12Ω/3W, winding resistance, required |
| MOV | 14D561 |
| LDM | 2.2mH/max: 4Ω/min: 0.2A |
| LCM1 | 200μH 0.8A |
| LCM2 | 12.6mH/min 0.5A |
| CX1/CX2 | 0.1μF/310Vac |
| CY1/CY3/CY4 | 1nF/400Vac |
| other | Reference Table for Peripheral Device Selection |

REVISION HISTORY

| rev. | description | date |
|------|-----------------|------------|
| 1.0 | initial release | 07/10/2025 |

The revision history provided is for informational purposes only and is believed to be accurate.



CUI INC

a bel group

15575 SW Sequoia Pkwy #100
Portland, OR 97224
800.275.4899

Fax 503.612.2383
Belfuse.com
powersupport@belf.com

CUI offers a two (2) year limited warranty. Complete warranty information is listed on our website.

CUI reserves the right to make changes to the product at any time without notice. Information provided by CUI is believed to be accurate and reliable. However, no responsibility is assumed by CUI for its use, nor for any infringements of patents or other rights of third parties which may result from its use.

CUI products are not authorized or warranted for use as critical components in equipment that requires an extremely high level of reliability. A critical component is any component of a life support device or system whose failure to perform can be reasonably expected to cause the failure of the life support device or system, or to affect its safety or effectiveness.