

**RoHS  
Compliant**



## Description:

Universal Switch Mode Power Supply with UK Plug, designed for efficient and reliable charging across a wide voltage range. Features a Type-C PD (Power Delivery) connector for fast and intelligent power output.

### 1.1 Input:

Voltage Range: 90V – 264V AC

Frequency Range: 47 – 63Hz

### 1.2 Output:

5V  $\approx$  3A

9V  $\approx$  2.22A

12V  $\approx$  1.67A

### 1.3 Connector:

USB Type-C (PD)

### 1.4 Applications:

Suitable for smartphones, tablets, portable electronics, and other USB-C PD compatible devices.

## 2. Input Current

0.6A max when input rated voltage and output rated load.

2.1 Unload Standby Power: 0.1W 115V/230Vac Max

2.2 In-Rush Current

50 A mps Max Cold start at 240Vac input ,with rated load and 25 °C ambient.

2.3 AC Leakage Current

0.25mA Max .At 240Vac input.

## 3. Output Characteristics

3.1 Method Of Measurement

Constant voltage

3.2 Rated Output Power: 20W

### 3.3 Combined Load/Line Regulation

Voltage	Min. Load	Max. Load	Load Regulation	Upload output voltage
CC +5V	0A	3.0A	4.75V-5.25V	4.75V-5.25V
CC +9V	0A	2.22A	8.55V-9.45V	8.55V-9.45V
CC+12V	0A	1.67A	11.40V-12.60V	11.40V-12.60V

### 3.4 Ripple And Noise

**Ripple & Noise:** Measurement is done by 20MHz bandwidth oscilloscope and the output paralleled a 0.1uF ceramic capacitor and a 47uF electrolysis capacitor. (test under the condition of rated input and rated output)

Voltage	Current	Ripple & Noise (Max)
+5V	3000mA	180m Vp-p
+9V	2220mA	180m Vp-p
+12V	1670mA	180m Vp-p

### 3.5 Efficiency

3.5.1 115VAC /230VAC input, output rated load is 25%, 50%, 75%, 100% 4 situations of average efficiency

### 3.6 Load Regulation

The rated output load is 20% - 100%, the input voltage is 100V - 240V AC, and the load adjustment within the load range is less than  $\pm 5\%$ .

### 3.7 Line Regulation

The line regulation of rated output voltage is less than  $\pm 0.5\%$  while measuring at rated load and 100V ~ 240V of input voltage changing.

### 3.8 Capacitive Load Test

Input voltage 115V - 230Vac, 80% load and parallel 1000uF capacitor output starts normally.

### 3.9 Output Transient Response

When the rated input voltage is 100V-240VAC, the output current changes at a slope of 0.5A/ $\mu$ s from 20% to 80% of the load and then back to 20% of the load and the dynamic change time is 10mS, the output voltage of the power supply should be kept in the range of  $12V \pm 10\%$ .

### 3.10 Turn On Delay Time

3 second Max .At 100Vac input and output Max. Load

### 3.11 Hold Up Time

5ms Min.at100Vac input and output Max .Load.

### 3.12 Rise Time

100ms Max. At 100Vac input and output Max. Load Output voltage 10% - 90%

### 3.13 Overshoot

10% Max. When power supply on or turn off.

## 3.14 Heterophonic Noise

In the standard silent room, make the product in working condition, put the sound level meter on the A-meter, test each side at 30cm of the front, back, left, right and upper sides of the product, take the maximum value, full voltage and full load range, less than 25dB.

## 4. PROTECTION FUNCTION

### 4.1 Short Circuit Protection

The Power Supply will be auto recovered when short circuit faults remove.

### 4.2 Over Current Protection

110-150% of rated current (input:110V-230Vac) When the overcurrent, the output will enter the hiccup mode, when the overcurrent situation is relieved, the product will automatically return to normal.

### 4.3 Over Voltage Protection

The power supply shall be self – recovering when the fault condition is removed.

## 5. ENVIRONMENTAL REQUIREMENTS

### 5.1 Operating Temperature

0°C to +40°C ,Full Load, Normal Operation.

### 5.2 Relative Humidity

5%(0°C) ~ 90%(40°C) 72h Full Load , Normal operating.

### 5.3 Storage Temperature

With enclosure:-20°C to +70°C

### 5.4 Storage Humidity

With enclosure: 20% to 80%

### 5.5 ALTITUDE : IPX0

## 6. MECHANICAL CHARACTERISTICS

### 6.1 Dropping Testing

The drop height of the wall-type product is: the wood floor is 1 meter, the fall of 6 faces, each face falls once, can not fall open, the product function and structure are normal, do 25kgf tensile test.

### 6.2 Vibration

Operating: IEC 721-3-3 3M3

5~9Hz, A = 1.5mm (9 ~ 200Hz, Acceleration 5m/s)

## 7 SAFETY STANDARD

7.1 Safety Accord with IEC62368-1, EN62368-1, UL62368-1, GB4943.1

**Note:** AC pins corresponding corresponding corresponding to national standards, such as the CE that corresponds to EN62368-1.

## 7.2 Dielectric Strength Hi-Pot

Primary to secondary, 4000Vdc(or 3000Vac ) /5mA/3s.

## 7.3 Insulation Resistance

Primary to secondary :100MΩ Min at 500V DC

## 8. RELIABILITY

### 8.1 MTBF

115V-230Vac power adapter at 25 environment and rated input and full load conditions, the average inte val failure time of at least 30,000 h.(reference standard License :MIL-HDBK-217F).

### 8.2 Burn-In

100% Bur-In with 100% loading & 40±5°C Environment temperature for 4 hours.

## 9. EMC STANDARD

The power supply shall meet the following standards

	Parameter	Standard	Performance Criterion
	Conducted emission	EN55032(CISPR32), GB/T 9254.1	Class B
<b>Electromagnetic compatibility emission</b>	Radiated emission	EN55032(CISPR32), GB/T 9254.1	ClassB
	Harmonic current	EN61000-3-2, GB 17625.1	ClassA
	Voltage flicker	EN61000-3-3; GB 17625.2	.....
	Parameter	Standard	Test conditions
	ESD	EN61000-4-2 GB /T 17626.2	8KV air, 4KV contact
<b>Electromagnetic compatibility immunity</b>	RF field susceptibility EFT bursts	EN61000-4-3 GB /T 17626.3 EN61000-4-4 GB /T 17626.4	Level2, 3V/m Level2, 1KV
	Surge susceptibility	EN61000-4-5 GB /T 17626.5	Differential mode +/-1KV
<b>EN55035(CISPR 35), GB/T 9254.2</b>	Conducted susceptibility	EN61000-4-6 GB /T 17626.6	Level 2, 3V
	Magnetic field immunity	EN61000-4-8 GB /T 17626.8	Level2, 1A/m
			0%UT ; 0.5P, Criterion: B
	Voltage dips, interruption	EN61000-4-11 GB /T 17626.11	70%UT; 25P/30P, Criterion: C 0%UT; 250P/300P, Criterion: C

## 10. GREEN REQUIREMENTS

### 10.1 Hazardous Substances

The components and used materials shall be in compliance with:

- Lead free process
- EU Directive 2015/863/EU “RoHS”
- REACH MEET/ EU 2006/1907/EC

## 11. FORM-IN-PLACE

Glue

## 12. WEIGHT

The weight of the power supply shall be 58±10g (Ref)

### DRAWING

Dimensions: mm

Tolerance: +/-0.5mm

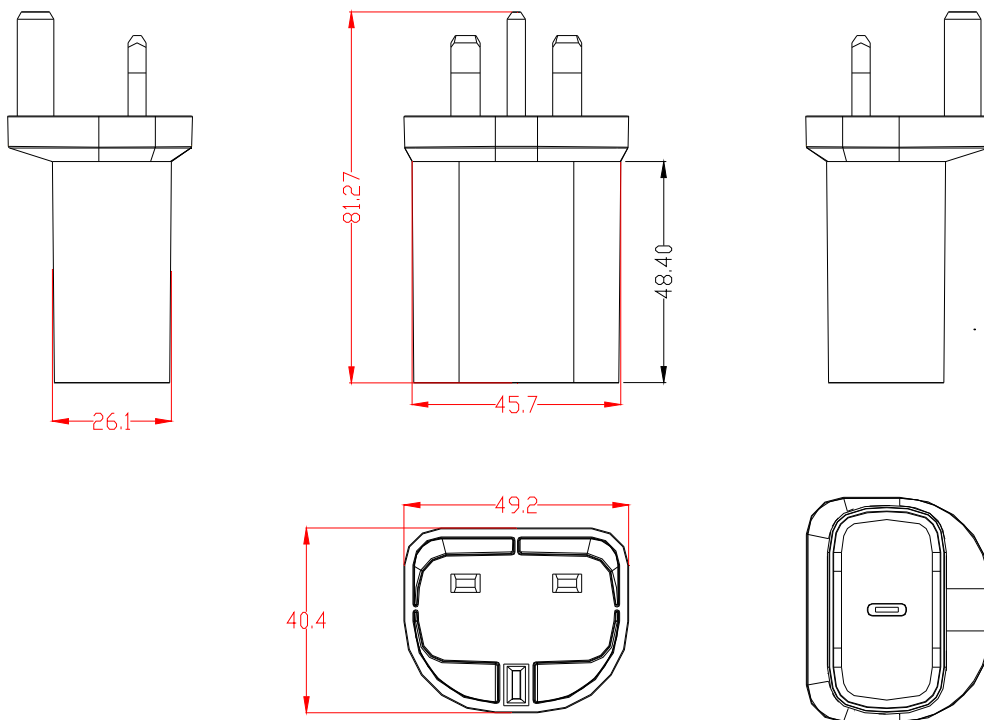

### Part Number Table

Description	Part Number
USB C PD Mains Charger, 1x USB C, 20W, Black	PELL0505
USB C PD Mains Charger, 1x USB C, 20W, White	PELL0506

**Important Notice** : This data sheet and its contents (the "Information") belong to pro-ELEC. No licence is granted for the use of it other than for information purposes in connection with the products to which it relates. No licence of any intellectual property rights is granted. The Information is subject to change without notice and replaces all data sheets previously supplied. The Information supplied is believed to be accurate but pro-ELEC assumes no responsibility for its accuracy or completeness, any error in or omission from it or for any use made of it. Users of this data sheet should check for themselves the Information and the suitability of the products for their purpose and not make any assumptions based on information included or omitted. Liability for loss or damage resulting from any reliance on the Information or use of it (including liability resulting from negligence or where pro-ELEC was aware of the possibility of such loss or damage arising) is excluded. This will not operate to limit or restrict pro-ELEC's liability for death or personal injury resulting from its negligence.