

FEATURES:

- High Density Power Module
- 3A Output Current
- Up to 95% Efficiency
- Input Voltage Range from 2.5V to 5.5V
- 0.6V to 4V Adjustable Output Voltage
- 100% Duty Cycle with Low Dropout
- 2MHz with Forced PWM Mode
- Enable Function
- Hiccup Mode for Shot Circuit and Over-Load Protection
- Internal Soft Start
- Compact Size: 2.5mm*2.0mm*1.3mm
- Pb-free for RoHS compliant
- MSL 2, 260C Reflow

APPLICATIONS:

- Optical modules
- Industrial PCs
- PLCs

GENERAL DESCRIPTION:

The module is non-isolated dc-dc converter that can deliver up to 3A of output current. The PWM switching regulator, high frequency power inductor are integrated in one hybrid package. It only needs input/output capacitors and one voltage dividing resistor to perform properly.

The module runs in forced-PWM maintaining a continuous conduction mode at all currents to minimize the output ripple, through constant on-time control, the module offers a simpler control loop and faster transient response. Other features include remote enable function, internal soft-start, non-latching over current protection, power good, input under voltage locked-out capability.

The low profile and compact size package (2.5mm × 2.0mm × 1.3mm) is suitable for automated assembly by standard surface mount equipment. The MUN3CAD03-JB power module is Pb-free and RoHS compliance.

TYPICAL APPLICATION CIRCUIT & PACKAGE:

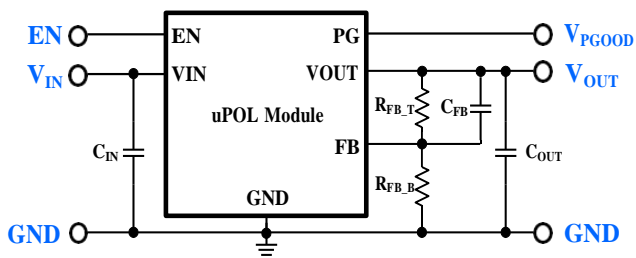

FIGURE 1 TYPICAL APPLICATION CIRCUIT

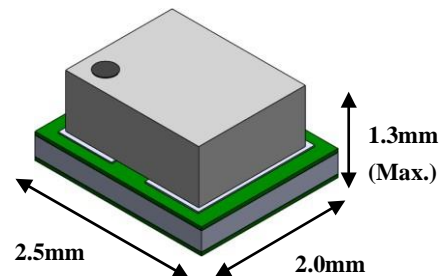

FIGURE 2 HIGH DENSITY LOW PROFILE
uPOL MODULE

ORDERING INFORMATION:

CAUTION: These devices have limited built-in ESD protection. The leads should be shorted together or the devices placed in conductive foam during the storage or handling to prevent electrostatic damage to internal circuit.

Part Number	Ambient Temp. Range (°C)	Package (Pb-Free)	MSL	Note
MHUN3CAD03JB	-40 ~ +125	DFN	Level 2	-

Order Code	Packing	Quantity
MUN3CAD03-JB	Tape and reel	2000

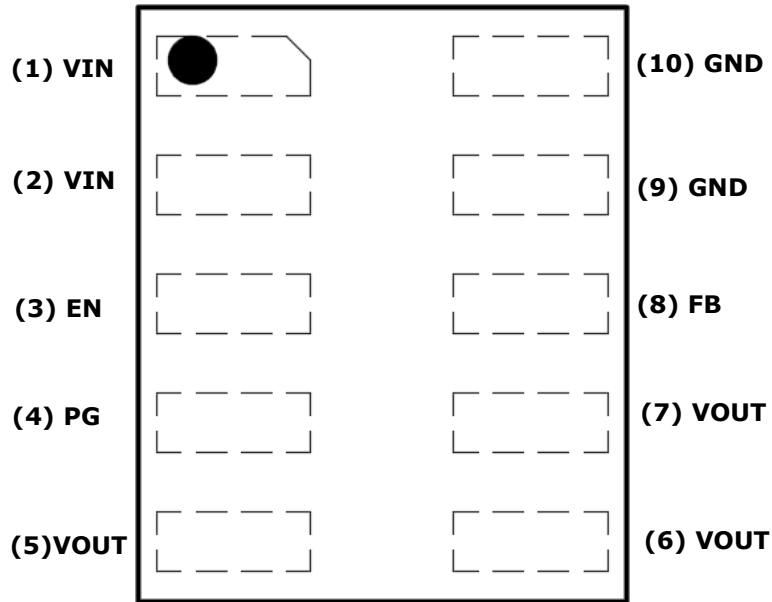
PIN CONFIGURATION:

TOP THROUGH VIEW
PIN DESCRIPTION:

Symbol	Pin No.	Description
VIN	1, 2	Power input pin. It needs to be connected to input rail with input capacitor. A 22uF capacitor at least for input.
EN	3	On/Off control pin for module. EN = LOW, the module is off. EN = HIGH, the module is on.
PGOOD	4	Power good output. It has an integrated the pull high internal 1 MΩ resistor to VIN.
VOUT	5, 6, 7	Power output pin. Connect to output for the load with output capacitor. A 22uF capacitor at least for output.
FB	8	Feedback input. Connect an external resistor divider to set the output voltage.
GND	9, 10	Power ground pin for signal, input, and output return path. This pin needs to be connected to one or more ground plane directly. Connect to thermal exposed pad of GND for heat transferring.

ELECTRICAL SPECIFICATIONS:

CAUTION: Do not operate at or near absolute maximum rating listed for extended periods of time. This stress may adversely impact product reliability and result in failures outside of warranty.

Parameter	Description	Min.	Typ.	Max.	Unit
■ Absolute Maximum Ratings					
VIN to GND		-	-	-0.3 to +6	V
VOUT to GND		-	-	-0.3 to +6	V
EN, PGOOD, FB to GND		-	-	-0.3 to +6	V
Tc	Case Temperature of Inductor	-	-	+125	°C
Tj	Junction Temperature	-40	-	+150	°C
Tstg	Storage Temperature	-40	-	+125	°C
ESD Rating	Human Body Model (HBM)	-	-	2k	V
	Machine Model (MM)	-	-	200	V
	Charge Device Model (CDM)	-	-	1k	V
■ Recommendation Operating Ratings					
VIN	Input Supply Voltage	+2.5	-	+5.5	V
IOUT	Output Current Range	0	-	3	A
Ta	Ambient Temperature	-40	-	+125	°C
■ Thermal Information					
Rth(jchoke-a)	Thermal resistance from junction to ambient. (Note 1)	-	34.8	-	°C/W

NOTES:

1. Rth(jchoke-a) is measured with the component mounted on an effective thermal conductivity test board on 0 LFM condition. The test board size is 30mm×30mm×1.6mm with 4 layers. The test condition is compliant with JEDEC EIJ/JESD 51 Standards.

ELECTRICAL SPECIFICATIONS: (Cont.)

Conditions: $T_A = 25\text{ }^\circ\text{C}$, unless otherwise specified. Test Board Information: 30mm×30mm×1.6mm, 4 layers, 2oz. The output ripple and transient response are measured by short loop probing and limited to 20MHz bandwidth. $C_{in} = 22\mu\text{F}/6.3\text{V}/0603*1$, $C_{out} = 22\mu\text{F}/6.3\text{V}/0603*1$.

Symbol	Parameter	Conditions	Min.	Typ.	Max.	Unit
■ Input Characteristics						
I_Q	Quiescent current	$I_{out} = 0, V_{FB} = V_{REF} * 105\%$	-	500	-	μA
$I_{SD(IN)}$	Input shutdown current	$V_{in} = 3.3\text{V}, EN = \text{GND}$	-	0.1	-	μA
V_{UVLO}	Undervoltage lockout threshold	V_{in} Increasing	2.3	2.4	2.5	V
	Undervoltage lockout hysteresis		-	250	-	mV
$I_{S(IN)}$	Input supply current	$V_{in} = 3.3\text{V}, EN = V_{IN}$	-	-	-	-
		$I_{out} = 0\text{A}, V_{out} = 1.8\text{V}$	-	17	-	mA
		$I_{out} = 3\text{A}, V_{out} = 1.8\text{V}$	-	1.83	-	A
■ Control Characteristics						
V_{FB}	Feedback regulation voltage	PWM Mode	0.591	0.6	0.609	V
F_{OSC}	Oscillator frequency	PWM Operation	-	2.0	-	MHz
V_{PG}	PGOOD threshold	V_{PG} rising	88	90	92	%
		V_{PG} falling	-	85	-	%
R_{PG_PU}	PGOOD pull-up resistor	Internal pull-up to V_{in}	-	1	-	$\text{M}\Omega$
V_{PGL}	PGOOD output low	$V_{FB} = 0.5\text{V}, \text{sink } 1\text{mA}$	-	0.2	-	V
t_{SS}	Soft-start time		-	600	-	μs
V_{EN_TH}	Enable rising threshold voltage		1.6	-	-	V
	Enable falling threshold voltage		-	-	0.5	V
R_{EN_PD}	EN internal pull down resistor		-	1	-	$\text{M}\Omega$
T_{OTP}	Over temp protection		-	160	-	$^\circ\text{C}$
OCP	Protection Output Current		-	5	-	A

TYPICAL PERFORMANCE CHARACTERISTICS: (3.3V_{OUT})

Conditions: $T_A = 25\text{ }^\circ\text{C}$, unless otherwise specified. Test Board Information: 30mm×30mm×1.6mm, 4 layers. The output ripple and transient response are measured by short loop probing and limited to 20 MegHz bandwidth. $V_{IN} = 5.0\text{V}$, $V_{OUT} = 3.3\text{V}$, unless otherwise noted.

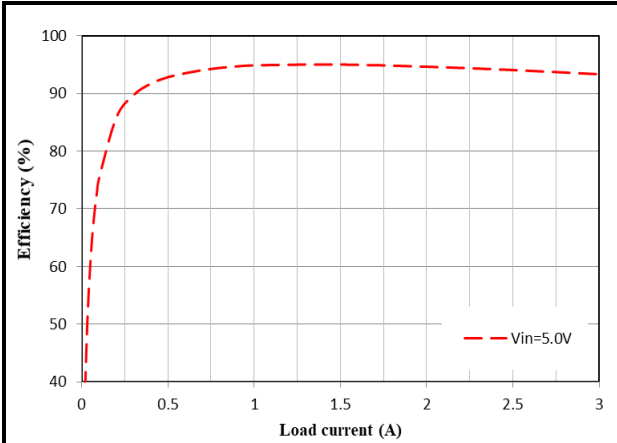
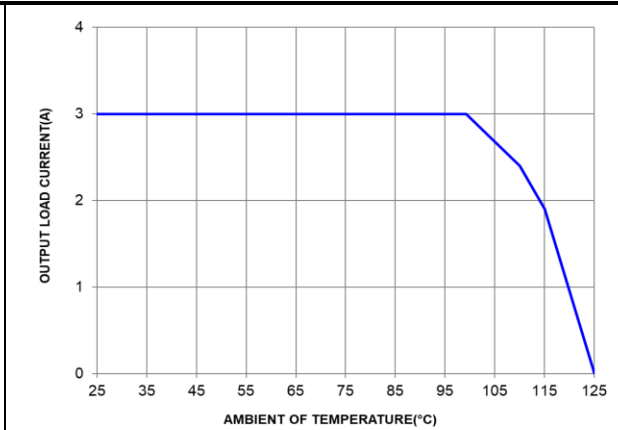
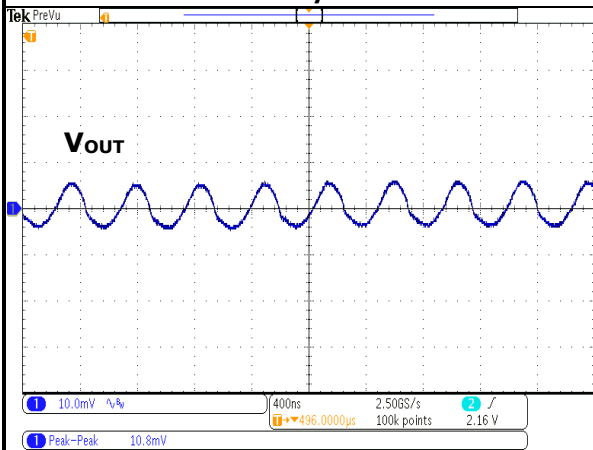
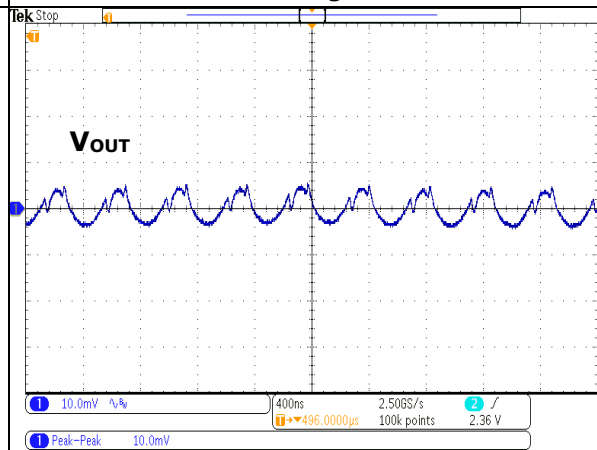
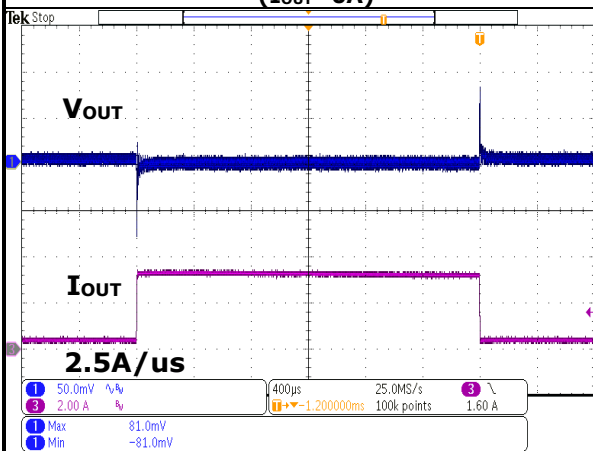
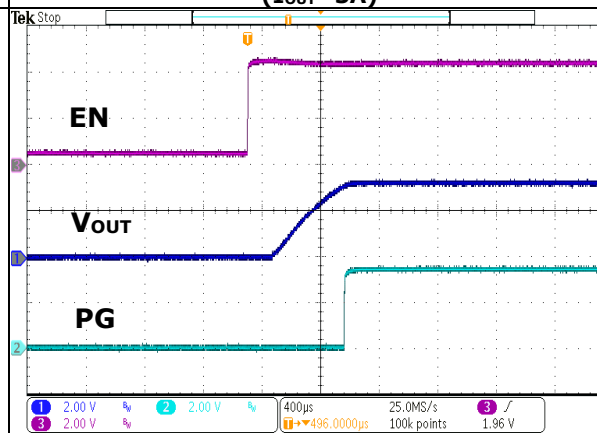
FIGURE 3 Efficiency V.S. Load Current

FIGURE 4 De-rating Curve at 5.0V_{IN}

**FIGURE 5 Output Ripple at 5.0V_{IN}
(I_{OUT}=0A)**

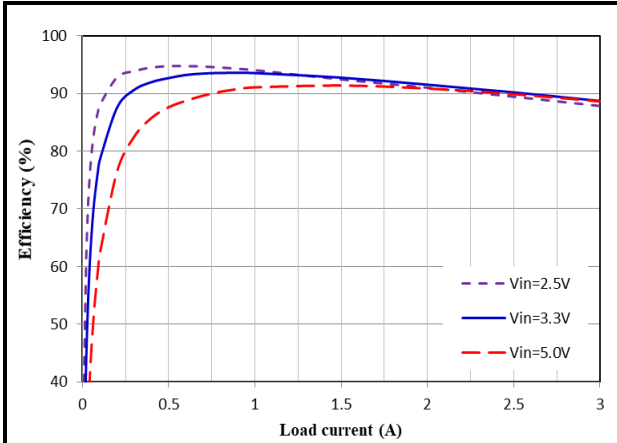
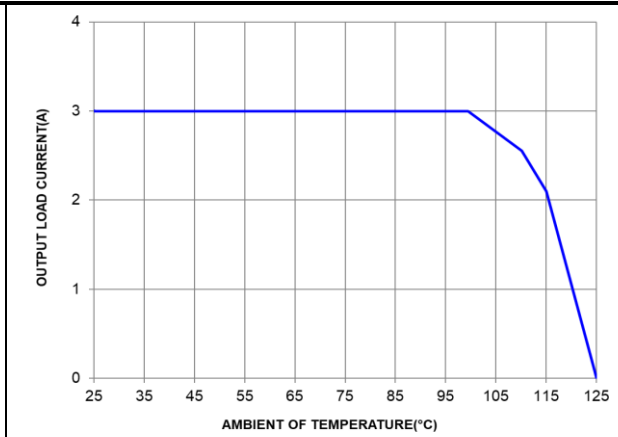
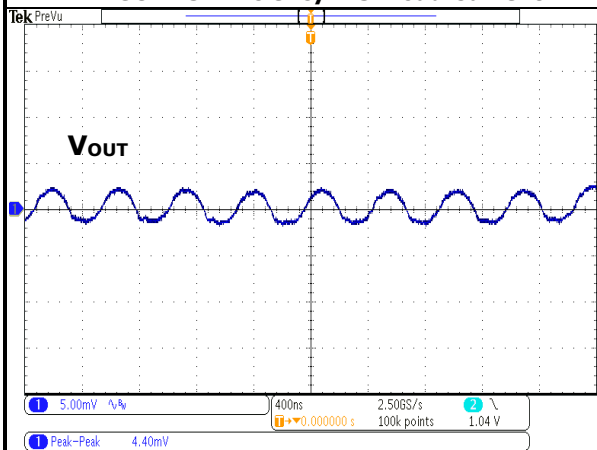
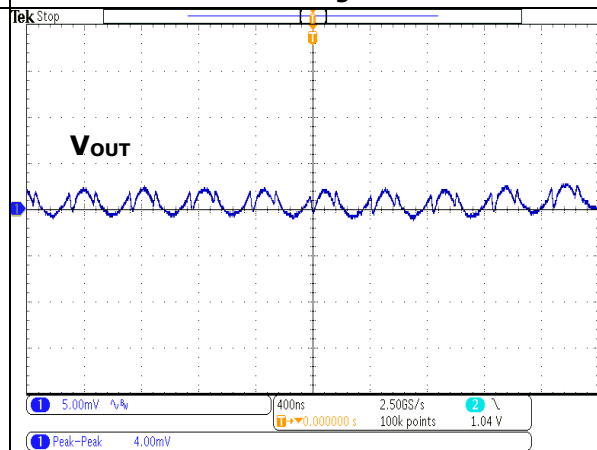
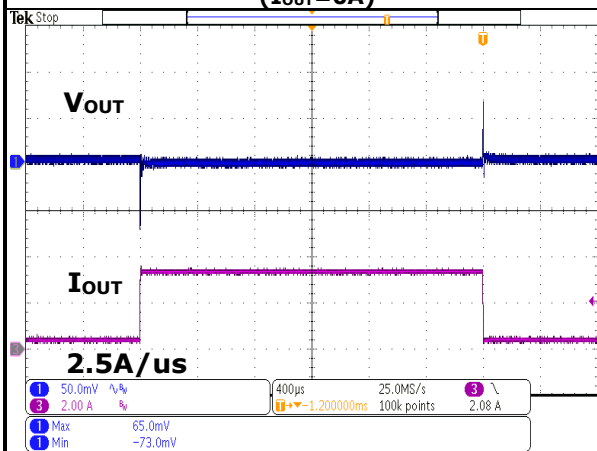
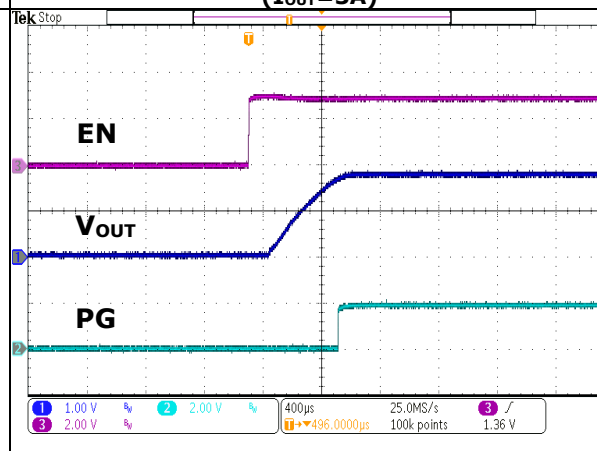
**FIGURE 6 Output Ripple at 5.0V_{IN}
(I_{OUT}=3A)**

**FIGURE 7 Transient Response
(V_{IN}=5.0V, I_{OUT}=0.3A~3A)**

**FIGURE 8 Turn-On
(V_{IN}=5.0V, I_{OUT}=3A)**

TYPICAL PERFORMANCE CHARACTERISTICS: (1.8V_{OUT})

Conditions: $T_A = 25\text{ }^\circ\text{C}$, unless otherwise specified. Test Board Information: 30mm×30mm×1.6mm, 4 layers. The output ripple and transient response are measured by short loop probing and limited to 20 MegHz bandwidth. $V_{IN} = 3.3\text{V}$, $V_{OUT} = 1.8\text{V}$, unless otherwise noted.

FIGURE 9 Efficiency V.S. Load Current

FIGURE 10 De-rating Curve at 3.3V_{IN}

**FIGURE 11 Output Ripple at 3.3V_{IN}
(I_{OUT}=0A)**

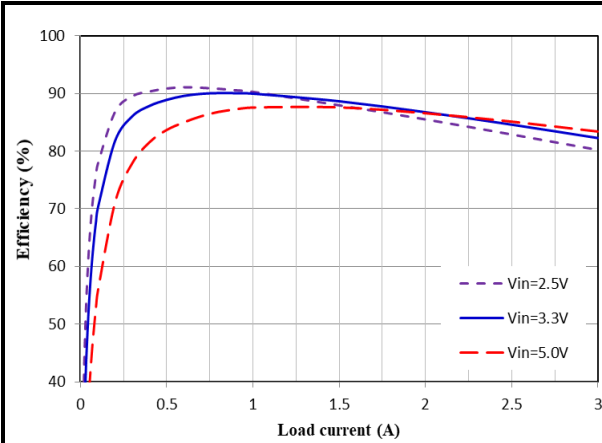
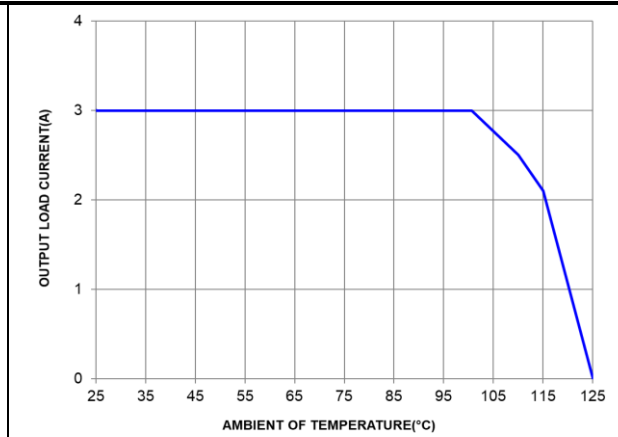
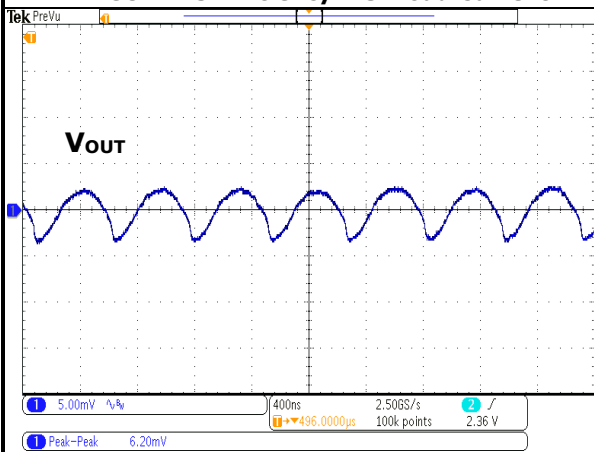
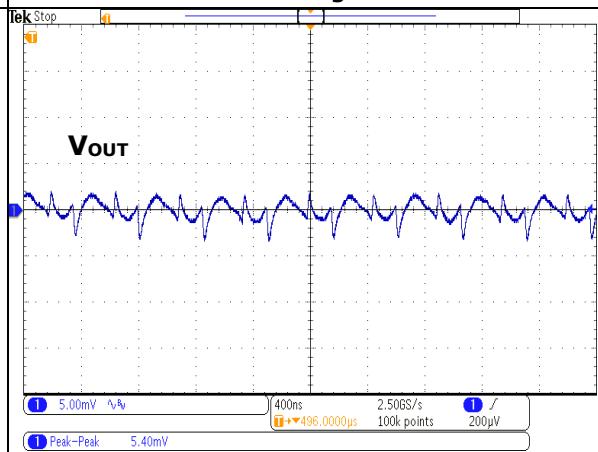
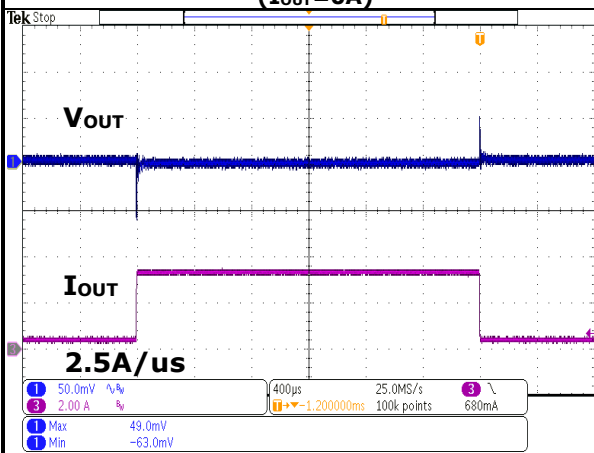
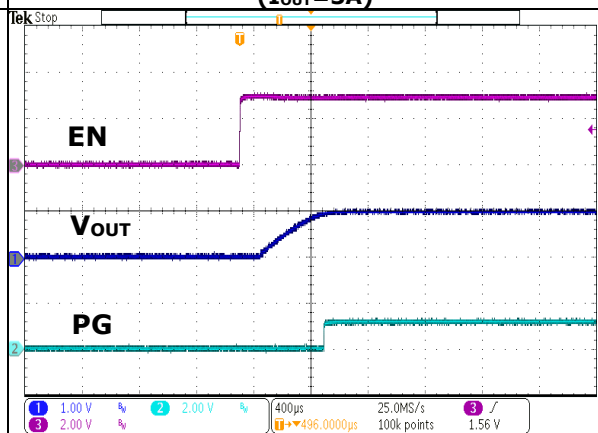
**FIGURE 12 Output Ripple at 3.3V_{IN}
(I_{OUT}=3A)**

**FIGURE 13 Transient Response
(V_{IN}=3.3V, I_{OUT}=0.3A~3A)**

**FIGURE 14 Turn-On
(V_{IN}=3.3V, I_{OUT}=3A)**

TYPICAL PERFORMANCE CHARACTERISTICS: (1.0V_{OUT})

Conditions: $T_A = 25\text{ }^\circ\text{C}$, unless otherwise specified. Test Board Information: 30mm×30mm×1.6mm, 4 layers. The output ripple and transient response are measured by short loop probing and limited to 20 MegHz bandwidth. $V_{in} = 3.3\text{V}$, $V_{out} = 1.0\text{V}$, unless otherwise noted.

FIGURE 15 Efficiency V.S. Load Current

FIGURE 16 De-rating Curve at 3.3V_{IN}

**FIGURE 17 Output Ripple at 3.3V_{IN}
($I_{OUT}=0\text{A}$)**

**FIGURE 18 Output Ripple at 3.3V_{IN}
($I_{OUT}=3\text{A}$)**

**FIGURE 19 Transient Response
($V_{IN}=3.3\text{V}, I_{OUT}=0.3\text{A}\sim 3\text{A}$)**

**FIGURE 20 Turn-On
($V_{IN}=3.3\text{V}, I_{OUT}=3\text{A}$)**

APPLICATIONS INFORMATION:
REFERENCE CIRCUIT FOR GENERAL APPLICATION:

The Figure 21 shows the module application schematics for input voltage +5V or +3.3V and turn on by input voltage directly through enable resistor.

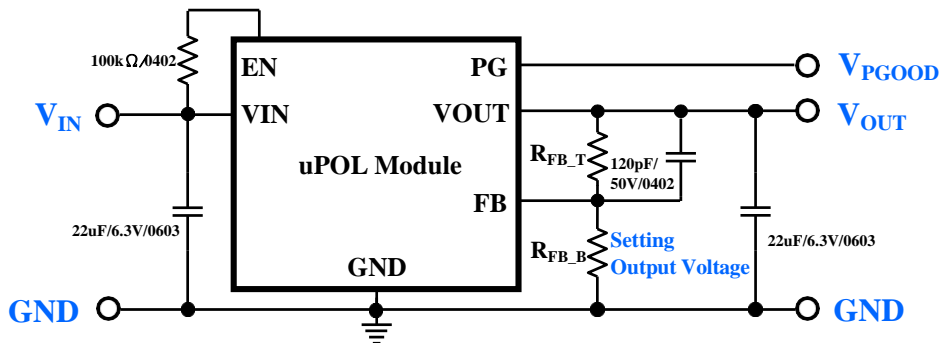

FIGURE 21. GENERAL APPLICATION CIRCUIT WITH TURN-ON BY INPUT VOLTAGE

SAFETY CONSIDERATIONS:

Certain applications and/or safety agencies may require fuses at the inputs of power conversion components. Fuses should also be used when there is the possibility of sustained input voltage reversal which is not current limited. For greatest safety, we recommend a fast blow fuse installed in the ungrounded input supply line. The installer must observe all relevant safety standards and regulations. For safety agency approvals, install the converter in compliance with the end-user safety standard.

INPUT FILTERING:

The module should be connected to a source supply of low AC impedance and high inductance in which line inductance can affect the module stability. An input capacitor must be placed as near as possible to the input pin of the module so to minimize input ripple voltage and ensure module stability.

OUTPUT FILTERING:

To reduce output ripple and improve the dynamic response as the step load changes, an additional capacitor at the output must be connected. Low ESR polymer and ceramic capacitors are recommended to improve the output ripple and dynamic response of the module.

APPLICATIONS INFORMATION:
PROGRAMMING OUTPUT VOLTAGE:

The module has an internal $0.6V \pm 1.5\%$ reference voltage. The output voltage can be programmed by the dividing resistor (R_{FB_T} and R_{FB_B}). The output voltage can be calculated by Equation 1, resistor choice may be referred to TABLE 1.

$$V_{OUT}(V) = 0.6 \times \left(1 + \frac{R_{FB_T}}{R_{FB_B}} \right) \tag{EQ.1}$$

TABLE 1 Resistor values for common output voltages

V_{OUT} (V)	$R_{FB_T}(k\Omega)$	$R_{FB_B}(k\Omega)$
1.0	100	150
1.2	100	100
1.8	100	49.9
3.3	100	22.1

THERMAL CONSIDERATIONS:

All of thermal testing condition is complied with JEDEC EIJ/JESD 51 Standards. Therefore, the test board size is $30mm \times 30mm \times 1.6mm$ with 4 layers. The case temperature of module sensing point is shown as Figure 22. Then $R_{th}(j_{choke-a})$ is measured with the component mounted on an effective thermal conductivity test board on 0 LFM condition. The MUN3CAD03-JB modules are designed for using when the case temperature is below $125^\circ C$ regardless the change of output current, input/output voltage or ambient temperature.

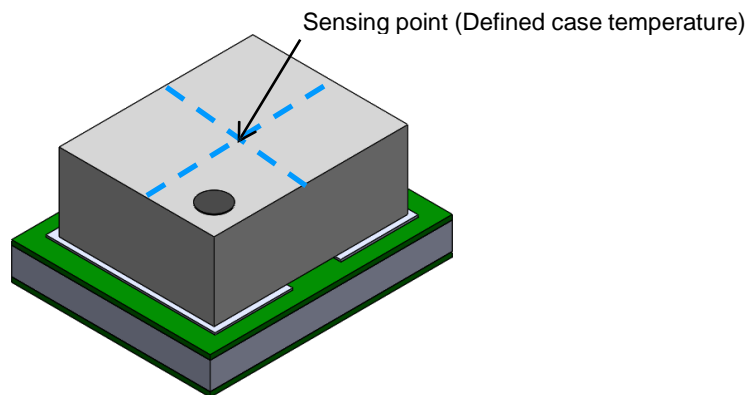
Figure 22. CASE TEMPERATURE SENSING POINT

APPLICATIONS INFORMATION: (Cont.)
REFLOW PARAMETERS:

Lead-free soldering process is a standard of electronic products production. Solder alloys like Sn/Ag, Sn/Ag/Cu and Sn/Ag/Bi are used extensively to replace the traditional Sn/Pb alloy. Sn/Ag/Cu alloy (SAC) is recommended for this power module process. In the SAC alloy series, SAC305 is a very popular solder alloy containing 3% Ag and 0.5% Cu and easy to obtain. Figure 23 shows an example of the reflow profile diagram. Typically, the profile has three stages. During the initial stage from room temperature to 150°C, the ramp rate of temperature should not be more than 3°C/sec. The soak zone then occurs from 150°C to 200°C and should last for 60 to 120 seconds. Finally, keep at over 217°C for 60~150 seconds to melt the solder and make the peak temperature at the range from 255°C to 260°C (Do not exceed 30 sec). It is noted that the time of peak temperature should depend on the mass of the PCB board. The reflow profile is usually supported by the solder vendor and one should adopt it for optimization according to various solder type and various manufacturers' formulae.

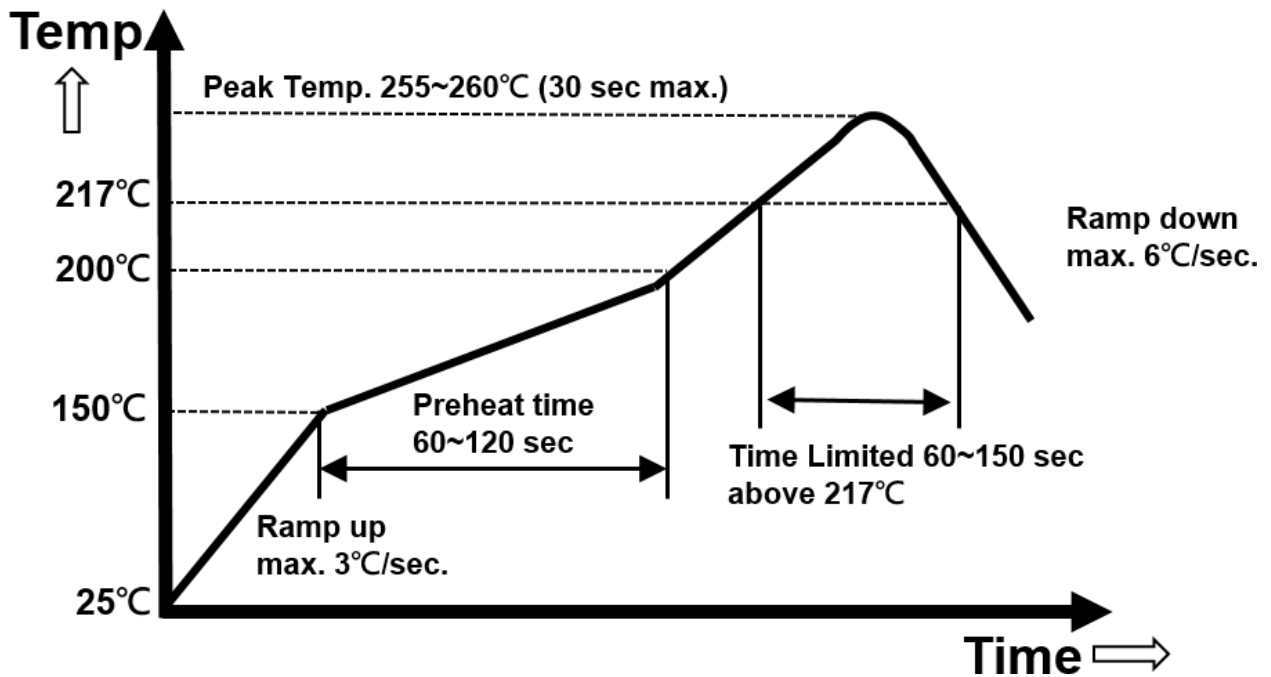
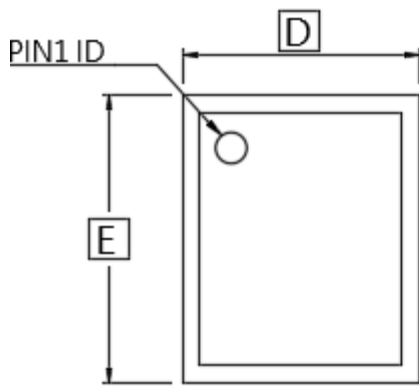

FIG.23 RECOMMENDATION REFLOW PROFILE*
(Not to scale)

*Refer to the Classification Reflow Profile of J-STD-020.

PACKAGE OUTLINE DRAWING:

Unit: mm



TOP VIEW

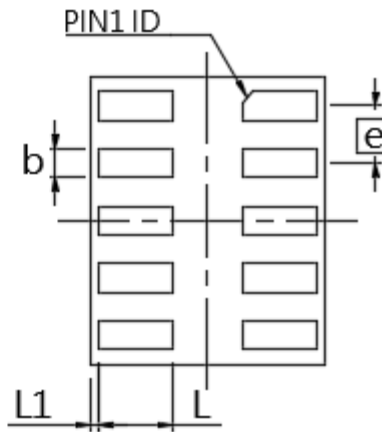

BOTTOM VIEW

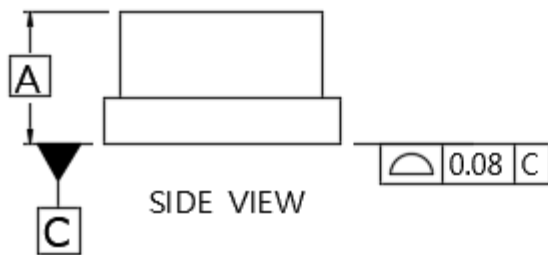

SIDE VIEW

DIM	MILLIMETERS		
	MIN	NOM	MAX
A	-	1.15	1.30
D	1.9	2.0	2.1
E	2.4	2.5	2.6
e	0.40	0.50	0.60
b	0.15	0.25	0.35
L	0.55	0.65	0.75
L1	0.00	0.05	0.15

LAND PATTERN REFERENCE:

Unit: mm

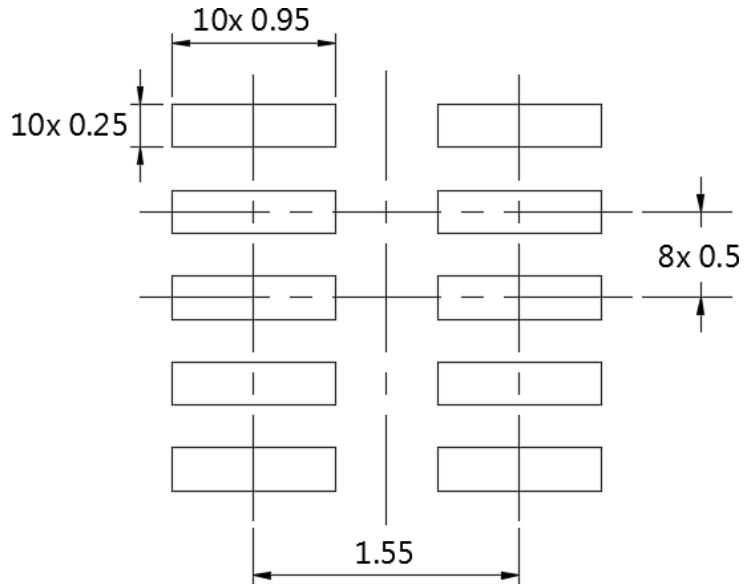
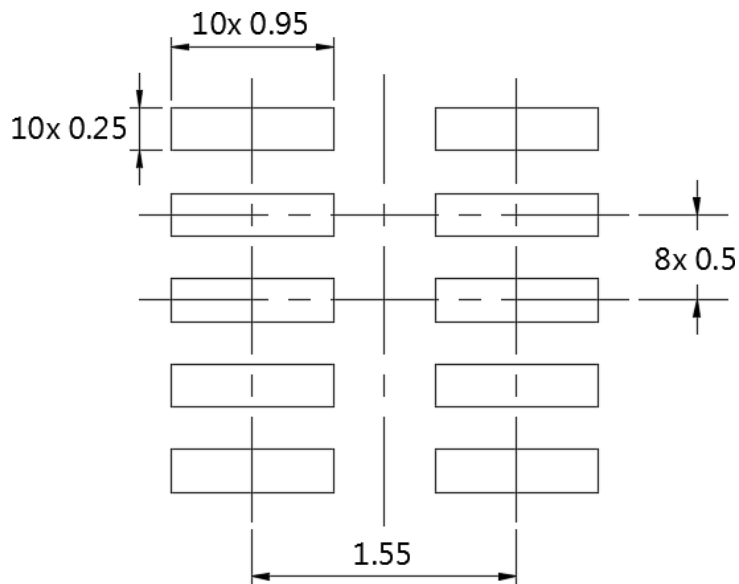

RECOMMENDED LAND PATTERN

RECOMMENDED STENCIL PATTERN*

*Based on 0.1~0.15mm thickness stencil (Reference only)

*Recommended solder paste coverage 55~100%

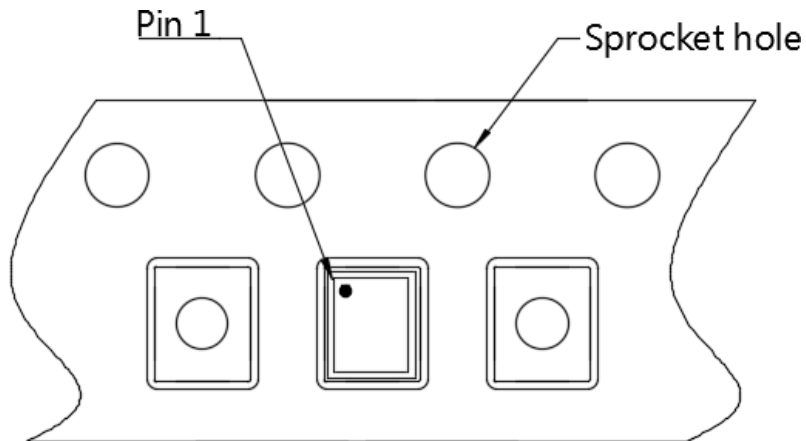
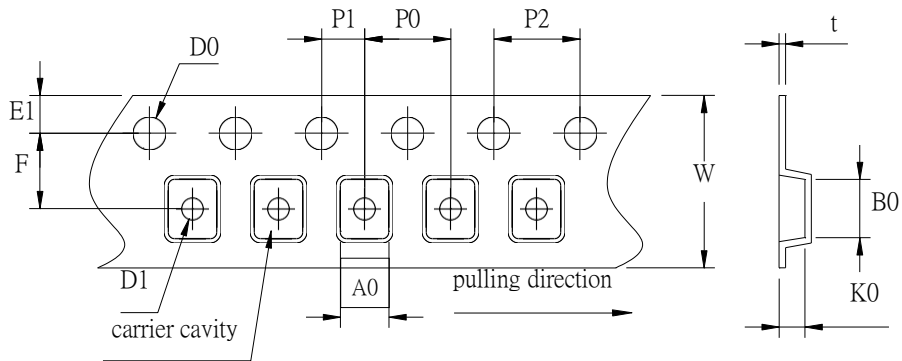
PACKING REFERENCE:

Unit: mm

Package In Tape Loading Orientation

Tape Dimension

A0	2.30	E1	1.75
B0	2.75	K0	1.55
F	3.50	P0	4.00
W	8.00	P1	2.00
D0	φ1.50	P2	4.00
D1	φ1.0	t	0.20

PACKING REFERENCE: (Cont.)

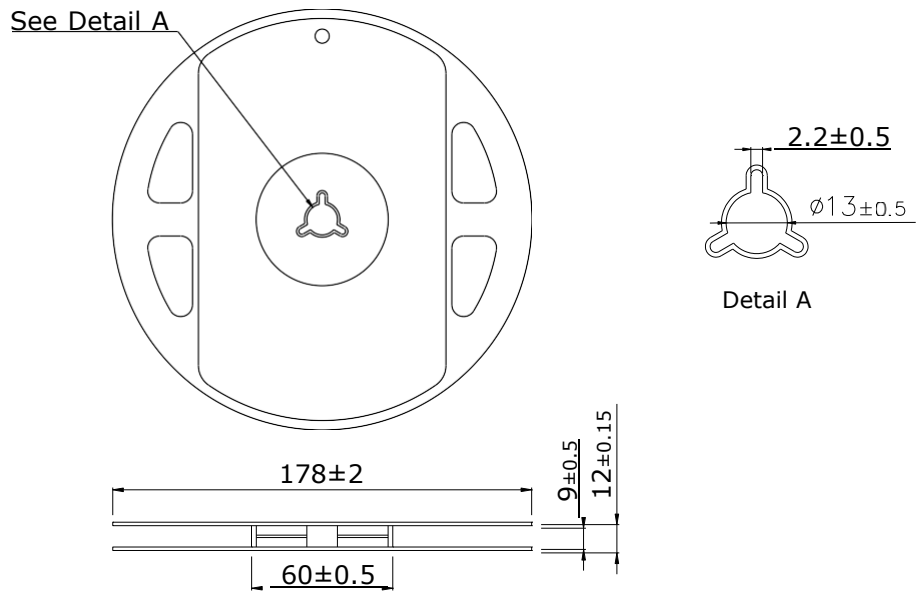
Unit: mm

Reel Dimension

Peel Strength of Top Cover Tape

The peel speed shall be about 300mm/min.

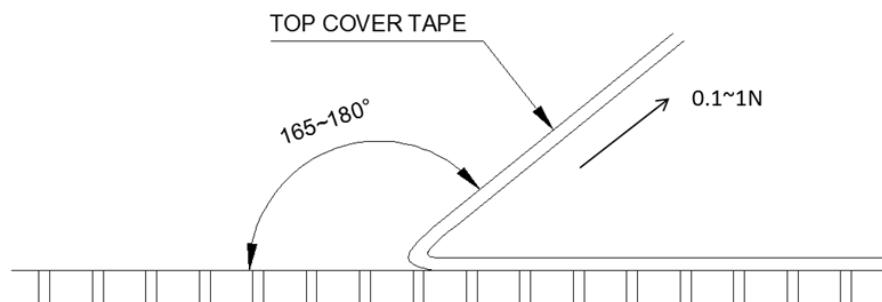
The peel force of top cover tape shall be between 0.1N to 1.0N



REVERSION HISTORY:

Date	Revision	Changes
2022.10.05	00	Initial released for preliminary datasheet.
2024.12.16	A1	Synchronized with document management number