

SICK.COM



DATA SHEET

**TIM361S-2134101**

TiM-S  
Safety laser scanners

**SICK** Sensor Intelligence

## SAFETY LASER SCANNERS

## TIM361S-2134101

## ORDERING INFORMATION

Type	part no.
TIM361S-2134101	1090608

Further device versions and accessories at [www.sick.com/TIM-S](http://www.sick.com/TIM-S)



## DETAILED TECHNICAL DATA

## FEATURES

Application	Indoor
System part	sensor
Measurement principle	HDDM
Light source	Infrared (850 nm)
Laser class	1 (IEC 60825-1:2014, EN 60825-1:2014+A11:2021)
Aperture angle	Horizontal 270°
Scanning frequency	15 Hz
Angular resolution	Horizontal 0.33°
Scan field flatness	± 1.5°
Working range	0.05 m ... 10 m (At > 90% remission factor)
Safety-related working range	0.05 m ... 4 m (At 5% remission factor)
Blind zone	0 m ... 0.05 m
Scanning range	At 10% remission factor 8 m

## MECHANICS/ELECTRONICS

Connection type	1 x "Ethernet" connection, 4-pin M12 female connector 1 x connection "Power", 12-pin, M12 male connector 1 x Micro USB female connector, type B
Supply voltage	9 V DC ... 28 V DC
Power consumption	Typ. 4 W, 16 W with 4 max. loaded digital outputs
Output current	≤ 100 mA

Housing color	Yellow
Enclosure rating	IP67, applies only when the plastic cover of the "Aux interface" is closed (IEC 60529:1989+AMD1:1999+AMD2:2013)
Protection class	III (IEC 61140:2016-1)
Weight	250 g, without connecting cables
Dimensions (L x W x H)	60 mm x 60 mm x 86 mm
MTBF	> 100 years

## SAFETY-RELATED PARAMETERS

Category	B (EN ISO 13849-1:2015)
Performance level	PL b (EN ISO 13849-1:2015)
Conformities	EN ISO 13849-1:2015, EN ISO 13482:2014, EN ISO 13855:2010, ANSI/ITSDF B56.5:2012
MTTF <sub>D</sub> (mean time to dangerous failure)	100 years, at 25 °C ambient temperature (EN ISO 13849-1:2015)
T <sub>M</sub> (mission time)	20 years (EN ISO 13849-1:2015)

## FUNCTIONS

Measured data output	Via Ethernet
----------------------	--------------

## PERFORMANCE

Response time	1 scan 2 scans, ≤ 134 ms <sup>1)</sup>
Detectable object shape	Almost any
Integrated application	Protective field evaluation with flexible fields
Protective field tolerance	100 mm, 0.66° (DIN CLC/TS 62046:2009, at 5% remission factor)
Number of field sets	16 field triples (48 protective fields)
Simultaneous evaluation cases	3 simultaneous protective fields (per field set)

<sup>1)</sup> At +45° to +225° of the working range; max. 150 ms at -45° to +45° of the working range.

## INTERFACES

USB		✓
	Remark	Micro USB
	Function	Service interface, parameterization
Digital inputs/outputs	Inputs	4 (PNP, for field set switching)
	Outputs	3 (PNP, to display a detection in the protective field, additional 1 x "Device Ready")
Delay time		67 ms ... 30,000 ms (configurable)
Dwell time		67 ms ... 600,052 ms (configurable)
Optical indicators		2 LEDs (ON, switching status)

**AMBIENT DATA**

Remission factor	≥ 5 % (reflectors) <sup>1)</sup>
Electromagnetic compatibility (EMC)	
Emitted radiation	Residential area (EN 61000-6-3:2007+AMD:A1:2011)
Electromagnetic immunity	Industrial environment (EN 61000-6-2:2005)
Vibration resistance	
Sine resonance scan	10 Hz ... 1,000 Hz <sup>2)</sup>
Sine test	10 Hz ... 500 Hz, 5 g, 10 frequency cycles <sup>2)</sup>
Noise test	10 Hz ... 250 Hz, 4.24 g RMS, 5 h <sup>3)</sup>
Shock resistance	
	50 g, 11 ms, ± 3 single shocks/axis <sup>4)</sup>
	25 g, 6 ms, ± 1,000 continuous shocks/axis <sup>4)</sup>
	50 g, 3 ms, ± 5,000 continuous shocks/axis <sup>4)</sup>
Ambient operating temperature	-10 °C ... +50 °C <sup>5)</sup>
Storage temperature	-40 °C ... +75 °C <sup>5)</sup>
Switch-on temperature	-10 °C ... +50 °C
Temperature change	-25 °C ... +50 °C, 10 cycles <sup>6)</sup>
Damp heat	+25 °C ... +55 °C, 95 % RH, 6 cycles <sup>7)</sup>
Relative humidity	
Operation	< 80 %, Non-condensing (EN 60068-2-30:2005)
Storage	≤ 90 %, Non-condensing (EN 60068-2-30:2005)
Ambient light immunity	
	60,000 lx
	3,000 lx, With direct light

<sup>1)</sup> When using reflectors, observe notes in the operating instructions.

<sup>2)</sup> IEC 60068-2-6:2007.

<sup>3)</sup> IEC 60068-2-64:2008.

<sup>4)</sup> IEC 60068-2-27:2008.

<sup>5)</sup> IEC 60068-2-14:2009.

<sup>6)</sup> EN 60068-2-14:2009.

<sup>7)</sup> EN 60068-2-30:2005.

**GENERAL NOTES**

Note on use	The TIM361S is a safety-related sensor that is suitable for use in the following applications: hazardous area, hazardous point, and access protection as well as mobile hazardous area protection (protection of automated guided vehicles and mobile platforms). The sensor must only ever be used within the limits of the prescribed and specified technical data and operating conditions.
-------------	--

**CERTIFICATES**

EU declaration of conformity	✓
UK declaration of conformity	✓
ACMA declaration of conformity	✓
China RoHS	✓
TÜV approval	✓
TÜV approval annex	✓
cTUVus certificate	✓
EC-Type-Examination approval	✓
Information according to Art. 3 of Data Act (Regulation EU 2023/2854)	✓

## DIMENSIONAL DRAWING

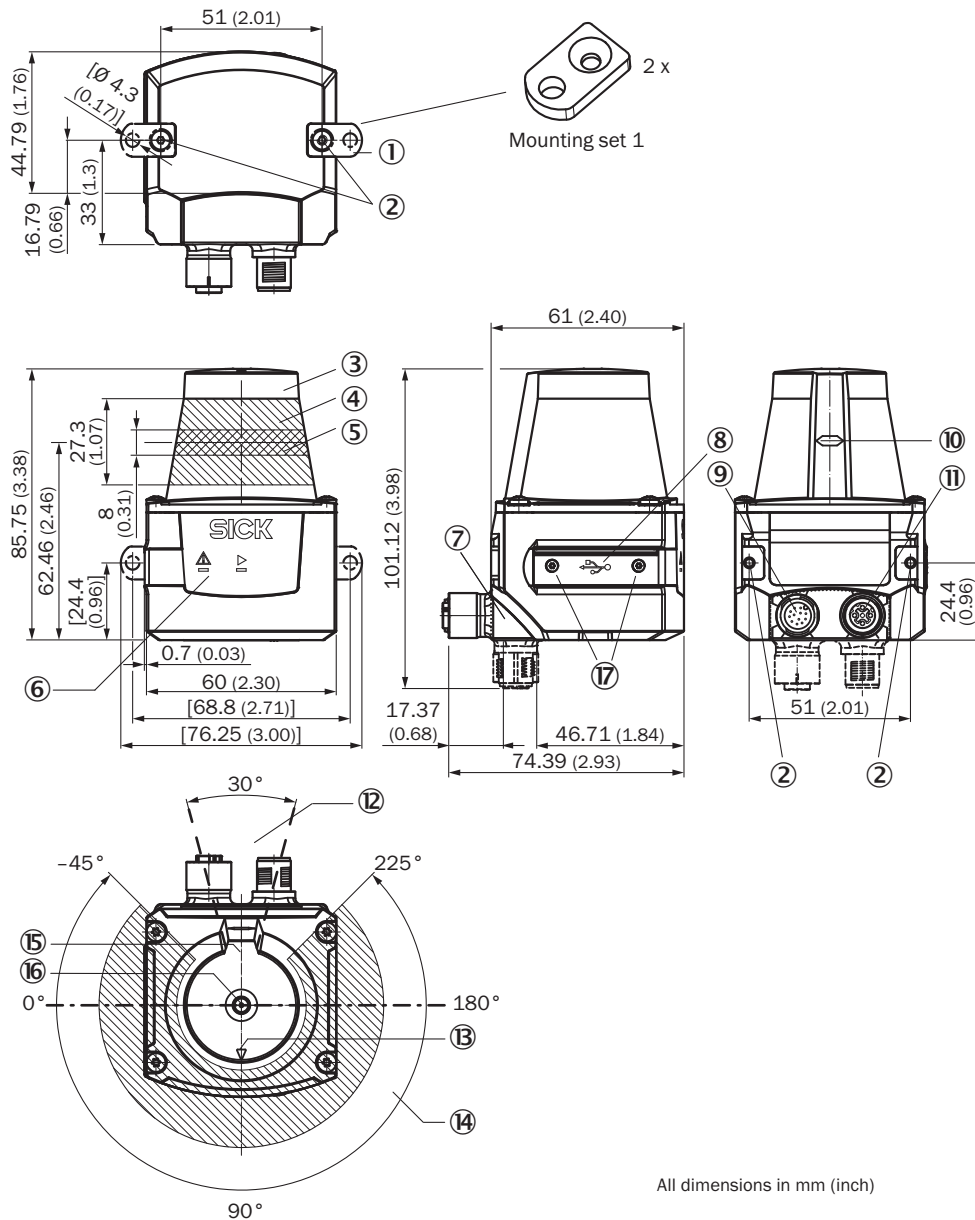

Dimensions in mm (inch)

- ① 2 x straight plates with M3 x 4 mm screw (included in delivery)
- ② M3 threaded mounting hole, 2.8 mm deep (blind hole thread), max. tightening torque 0.8 Nm
- ③ Optical hood
- ④ Receiving range (light inlet)
- ⑤ Transmission range (light emission)
- ⑥ Red and green LED (status displays)
- ⑦ swivel connector unit
- ⑧ Micro USB port, behind the black rubber plate ("Aux interface" connection for configuration with PC)
- ⑨ "Power/inputs and outputs" connection, 12-pin M12 male connector
- ⑩ Marking for the position of the light emission level
- ⑪ 4-pin M12 female connector: not assigned
- ⑫ Area in which no reflective surfaces are allowed for mounted devices
- ⑬ Bearing marking to support alignment (90° axis)
- ⑭ Aperture angle 270° (scanning angle)
- ⑮ Internal reference target
- ⑯ Measurement origin
- ⑰ 2 x countersunk screw (Torx TX 6) M2 x 4 mm

### PINOUTS POWER I/O CONNECTION

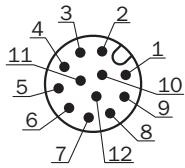

Connecting cable with male connector or M12 male connector, 12-pin, A-coded

- ① GND
- ② DC 9 V ... 28 V
- ③ In<sub>1</sub>
- ④ In<sub>2</sub>
- ⑤ OUT1
- ⑥ OUT2
- ⑦ OUT3
- ⑧ OUT4
- ⑨ PNP: INGND, NPN: IN 9 V ... 28 V
- ⑩ In<sub>3</sub>
- ⑪ In<sub>4</sub>
- ⑫ nc

### PINOUTS ETHERNET

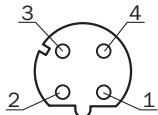

M12 female connector, 4-pin, D-coded

- ① TX+
- ② RX+
- ③ TX-
- ④ RX-

**WORKING RANGE DIAGRAM**

Scanning range in m (feet)

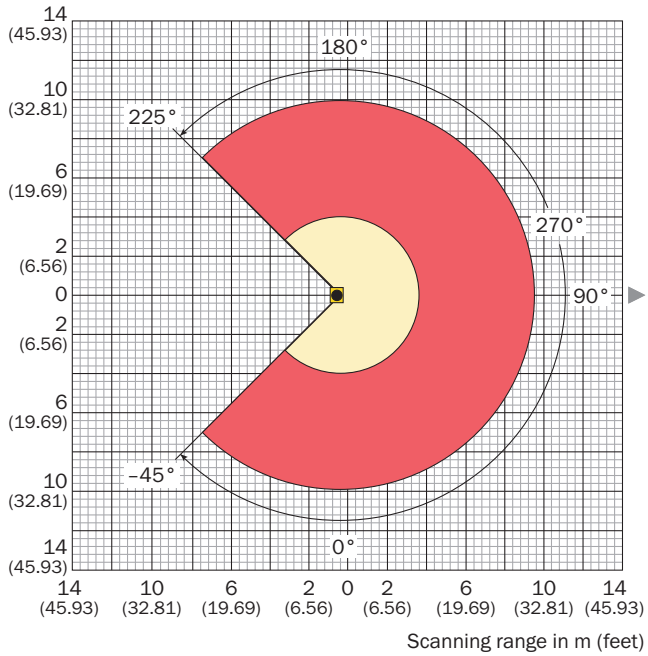

■ Range for **not safety-related** detection:  
0.05 m to max. 10 m (32.81 feet)

■ Range for **safety-related** detection:  
0.05 m to max. 4 m (13.21 feet)

**Attention!** From the measurement origin up to a distance of 0.05 m (0.17 feet) no objects are detected (blind zone!) over the entire radial field of view (scanning range of 270°).

Further information as well as suitable accessories, example applications and downloads such as CAD dimensional models, operating instructions and software can be found at [www.sick.com/1090608](http://www.sick.com/1090608)



SICK AG  
WALDKIRCH  
GERMANY  
SICK.COM

# SICK AT A GLANCE

SICK is a leading global technology company for intelligent sensors and integrated solutions in industrial automation. Our technologies set benchmarks, making your industrial processes more efficient, safer and more sustainable – both in logistics and manufacturing operations.

SICK combines sensor intelligence with industry expertise and certified consulting services. We provide the ideal foundation for scalable as well as tailor-made automation solutions and create added value along the entire value chain. Our close partnerships with our customers are more than just a promise: Together, we optimize productivity, improve quality, protect health and safety, and help build a sustainable future. All with empathy and trust.

Since 1946, we have been developing innovative technologies with passion and a pioneering spirit. With a global network in around 40 countries, SICK has a global presence and is always close by. The company's headquarters are located in Waldkirch near Freiburg, Germany. Our customers benefit from our understanding of both local and global requirements, which enables us to deliver tailor-made solutions

**SICK**  
Sensor Intelligence