



TAOGLAS®



Datasheet

Part No:
GVLB256.A

Description

GPS/GLONASS/BeiDou Single Feed Stacked Patch L1:1575MHz L5:1176.45MHz
B1:1561MHz 25 x 25 x 6mm

Features:

Single Feed Stacked Patch Assembly
Covering the following Bands & Constellations:

- GPS L1 & L5
- BeiDou B1/B2a
- Galileo E1 & E5a
- GLONASS G1

Pin Mount

Dims: 25mm x 25mm x 6mm

RoHS & Reach Compliant

1.	Introduction	3
2.	Specification	4
3.	Mechanical Drawing	6
4.	Antenna Integration Guide	7
5.	Packaging	13
6.	Antenna Characteristics	14
7.	Radiation Patterns	18
<hr/>		
	Changelog	23

Taoglas makes no warranties based on the accuracy or completeness of the contents of this document and reserves the right to make changes to specifications and product descriptions at any time without notice. Taoglas reserves all rights to this document and the information contained herein. Reproduction, use or disclosure to third parties without express permission is strictly prohibited.

Ireland & USA
ISO 9001:2015
Certified



Taiwan
ISO 9001:2015
Certified



1. Introduction



The Taoglas GVLB256.A, is a dual-band GNSS L1/L5, high-performance antenna for high precision GNSS accuracy and fast positioning. It utilizes a 25 x 25 x 6mm advanced wide-band dual-stacked ceramic patch antenna with optimized gain for GPS L1/L5, Galileo, GLONASS and BeiDou. At 6mm in height, the GVLB256.A has a smaller form factor allowing for installation where height is at a premium.

Typical Applications Include:

- Automotive Navigation Systems
- Transportation
- Drones & UAVs
- Agriculture
- Industrial IoT Devices
- Timing & Synchronization

The GVLB256.A has been tuned and tested on a 70 x 70 mm ground plane and exhibits excellent radiation patterns, it has been optimized to cover the bands required for the next generation of L1/L5 GNSS receivers that are currently on the market.

Patch antennas can be specifically tuned to customer-specific device environments, subject to NRE and MOQ. Contact your regional Taoglas customer support team to request these services or additional support to integrate and test this antenna's performance in your device.

2. Specification

GNSS Frequency Bands					
GPS	L1 1575.42 MHz	L2 1227.6 MHz	L5 1176.45 MHz		
	■	□	■		
GLONASS	G1 1602 MHz	G2 1248 MHz	G3 1207 MHz		
	■	□	□		
Galileo	E1 1575.24 MHz	E5a 1176.45 MHz	E5b 1201.5 MHz	E6 1278.75 MHz	
	■	■	□	□	
BeiDou	B1C 1575.42 MHz	B1I 1561 MHz	B2a 1176.45 MHz	B2b 1207.14 MHz	B3 1268.52 MHz
	■	■	■	□	□
L-Band	L-Band 1542 MHz				
	□				
QZSS (Regional)	L1 1575.42 MHz	L2C 1227.6 MHz	L5 1176.45 MHz	L6 1278.75e6	
	■	□	■	□	
IRNSS (Regional)	L5 1176.45 MHz				
	■				
SBAS	L1/E1/B1 1575.42 MHz	L5/B2a/E5a 1176.45 MHz	G1 1602 MHz	G2 1248 MHz	G3 1207 MHz
	■	■	■	□	□

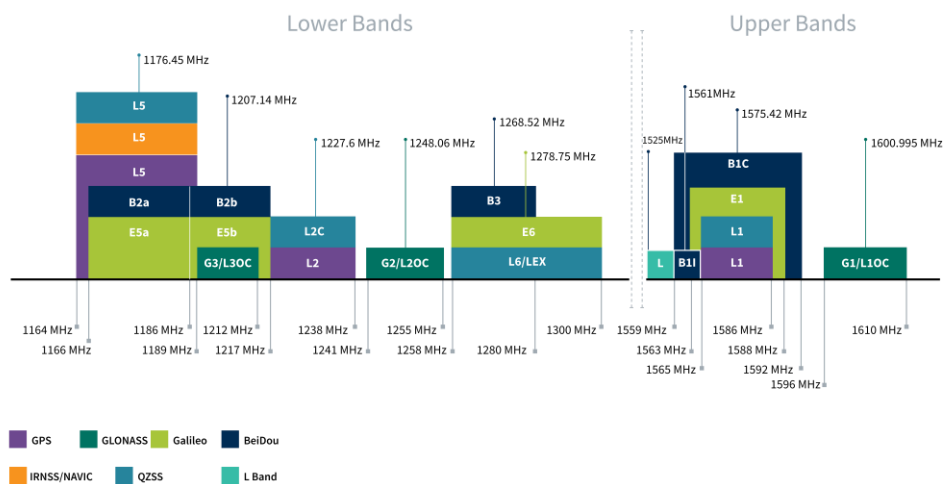

GNSS Bands and Constellations

GNSS Electrical				
Frequency (MHz)	1176.45	1561	1575.42	1603
VSWR (max.)	3:1			
Efficiency (%)	56.01	50.89	53.37	60.44
Gain (dBi)	1.18	1.71	2.09	2.61
Polarization	RHCP			
Impedance	50 Ω			

Mechanical	
Dimensions	25 x 25 x 6mm
Ground Plane	70 x 70mm
Weight	21g
Material	Ceramic
Antenna Type	Patch & Pin

Environmental	
Operation Temperature	-40°C to 105°C
Storage Temperature	-40°C to 105°C
Relative Humidity	Non-condensing 65°C 95% RH

3. Mechanical Drawing

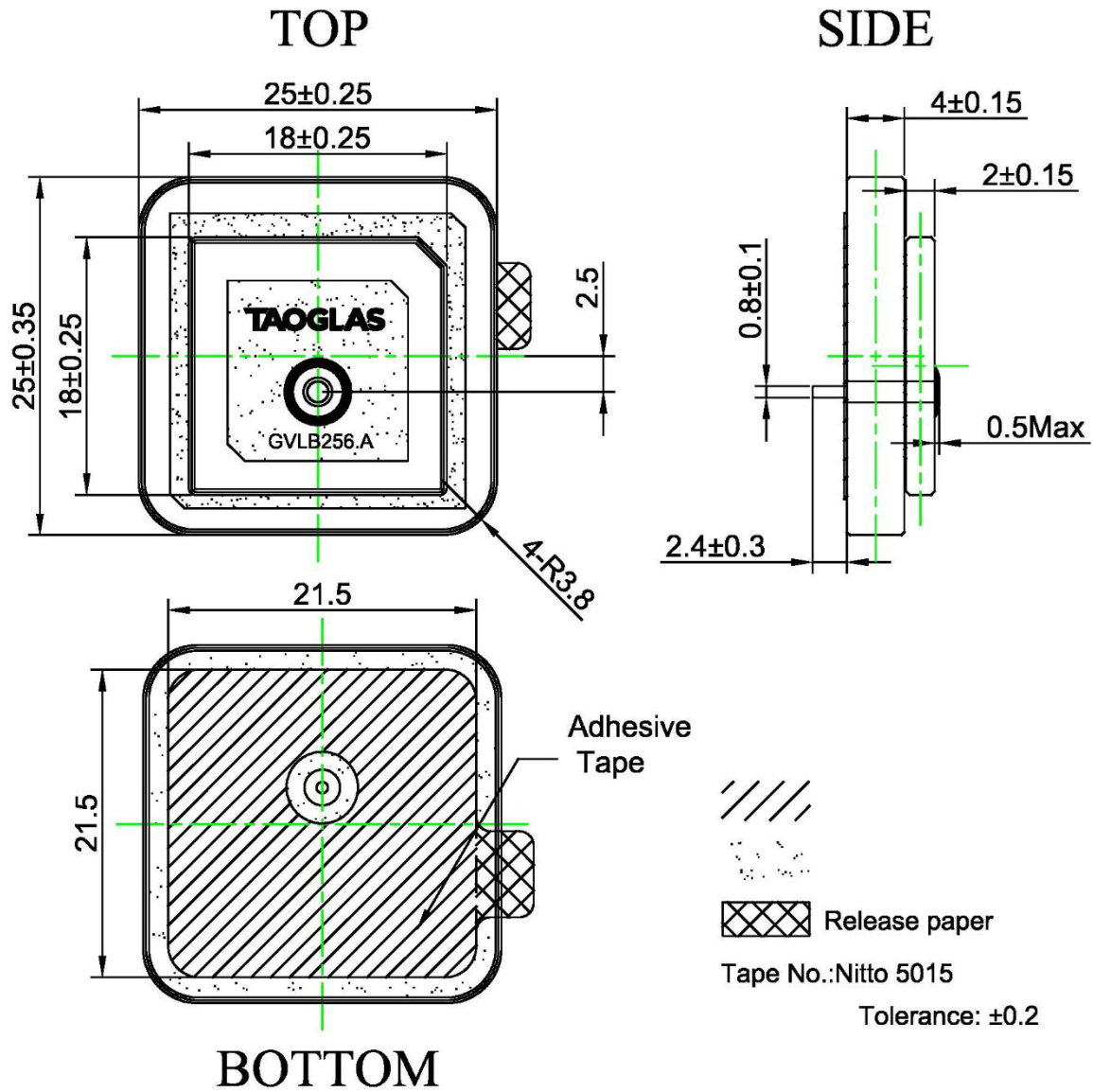

4. Antenna Integration Guide

The following is an example on how to integrate the GVLB256.A into a design. The GVLB256.A has one pin which is used for the RF Feed. Taoglas recommends using a minimum of 70x70mm ground plane to ensure optimal performance.



Top view of an example 70x70mm PCB Reference Design.

4.1 Schematic Symbol and Pin Definitions



Top view of an example 70x70mm PCB Reference Design.

The circuit symbol for a GVLB256.A is shown below. The antenna has 1 pin as indicated below.

Pin	Description
1	RF Feed

TAOGLAS_GVLB256A

ANTI



Above is a schematic symbol of the GVLB256.A and a table of the pin definitions.

4.2 Antenna Footprint

TOP

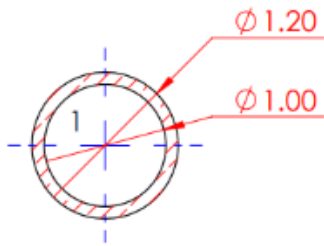

BOTTOM

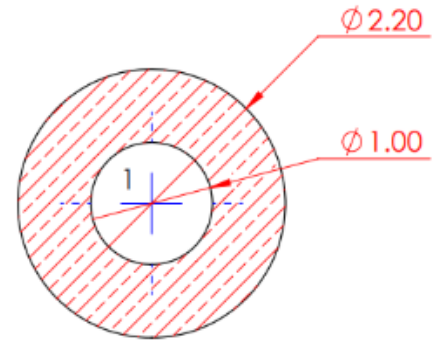

Pin	Description
1	RF Feed

4.3 Copper Clearance

The footprint and clearance on the PCB must comply with the antenna's specification. The PCB layout shown in the diagrams below demonstrates the GVLB256.A clearance area for Pin 1 (RF Feed Pad). The bottom copper keep out area only applies to the bottom layer and the top copper keep out area applies to all other layers.

There should be a $\varnothing 3\text{mm}$ copper clearance around the antenna pins on the top side of the PCB with a $\varnothing 3.5\text{mm}$ copper clearance around the antenna pins on the bottom side.

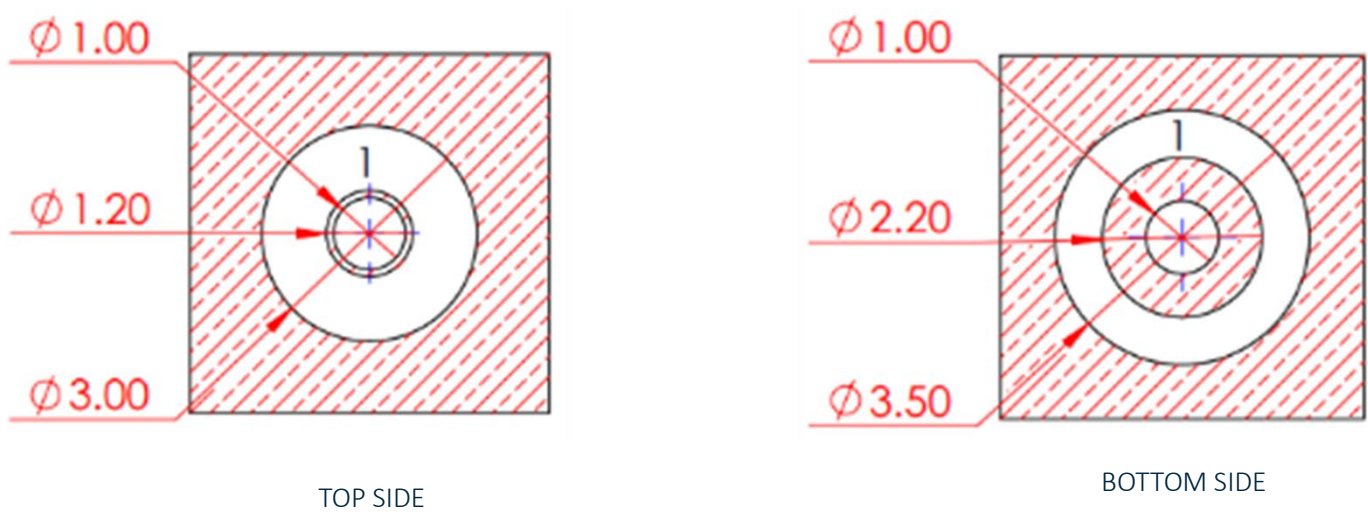

2D Images of Copper Clearances for the GVLB256.A

4.4 Antenna Integration

The GVLB256.A should be placed in the centre of the PCB to take advantage of the ground plane. The RF traces must maintain a 50 Ohm transmission line. Ground vias should be placed around the copper clearance area and the transmission line. Note that depending on the design application, tuning may be required for optimal performance. This may be achieved using a 'pi' matching network or custom tuning of the patch antenna.



Bottom view of the PCB Reference Design, showing transmission lines and integration notes.

4.5 Final Integration

The bottom side image shown below highlights the antenna transmission line. Taoglas recommends using a minimum of 70x70mm ground plane to ensure optimal performance.



Top Side (70x70mm example PCB Reference Design)

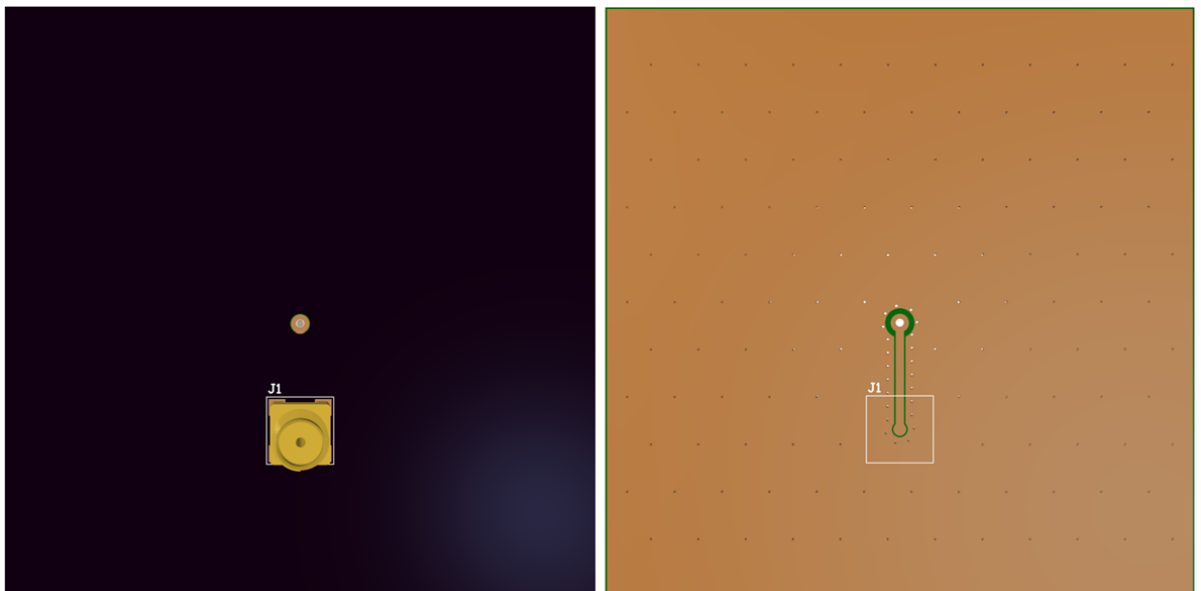

Bottom Side

5. Packaging

GVLB256.A
24 PCS / EPE foam board

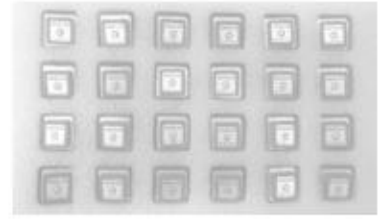

96 PCS / Vacuum package
1 PCS / 3g Desiccant



96 PCS / Small box
Small box (mm): 263x154x96

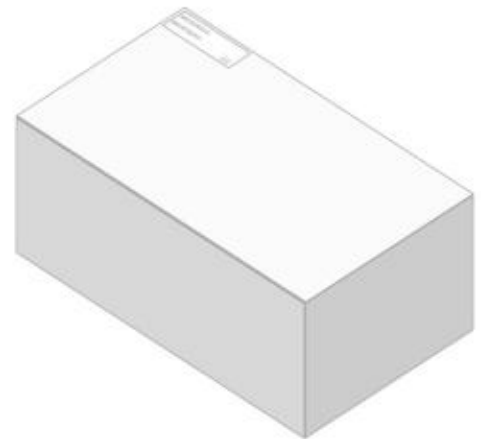

384 PCS / Carton
Carton(mm): 327x280x218
Carton Label



6. Antenna Characteristics

6.1 Test Setup

AUT



Vector Network Analyzer

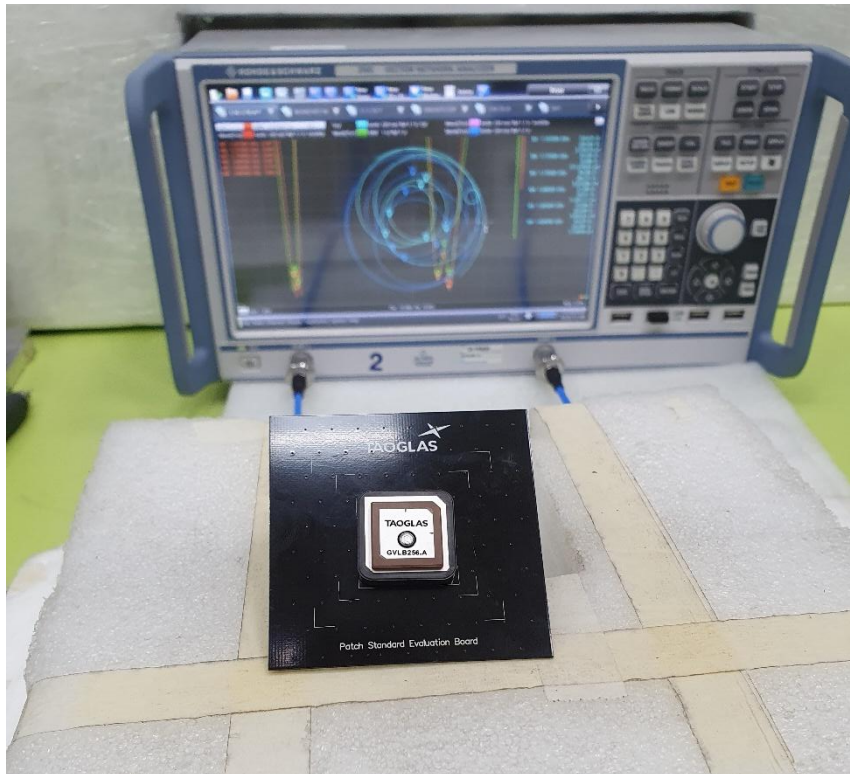

VNA Test Set-up

6.2 Return Loss

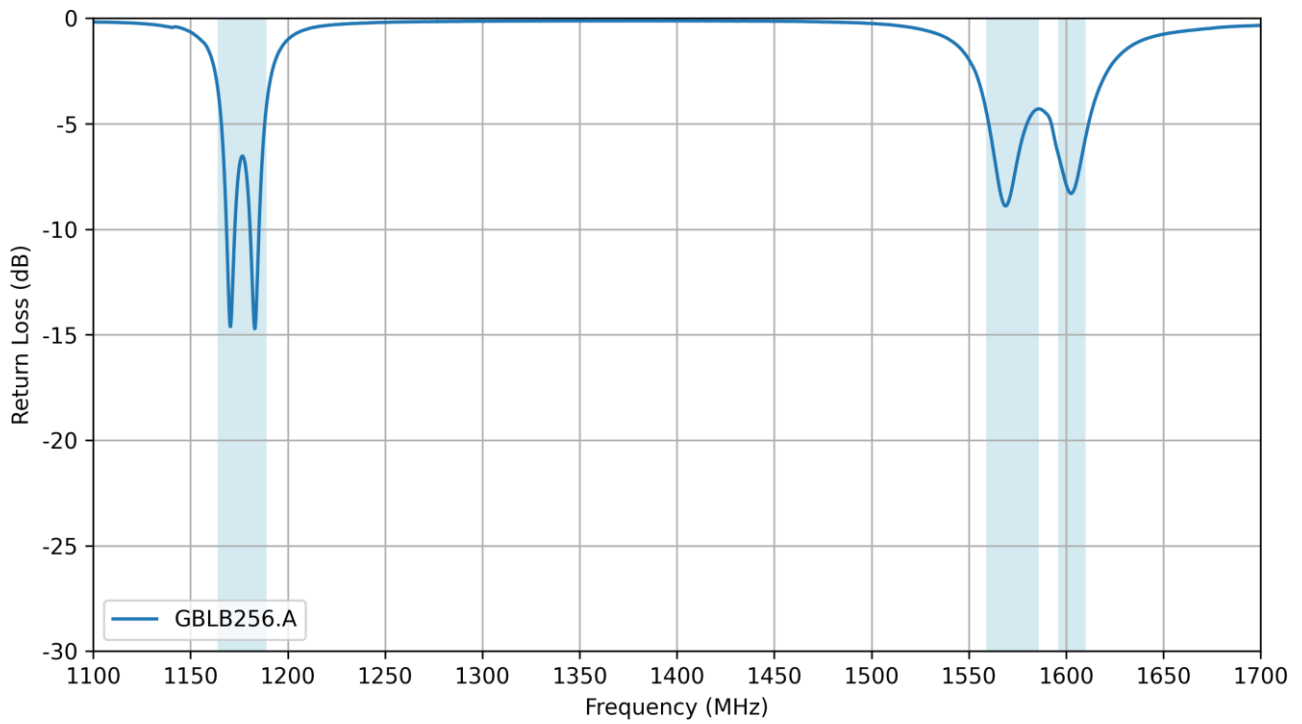

6.3 VSWR

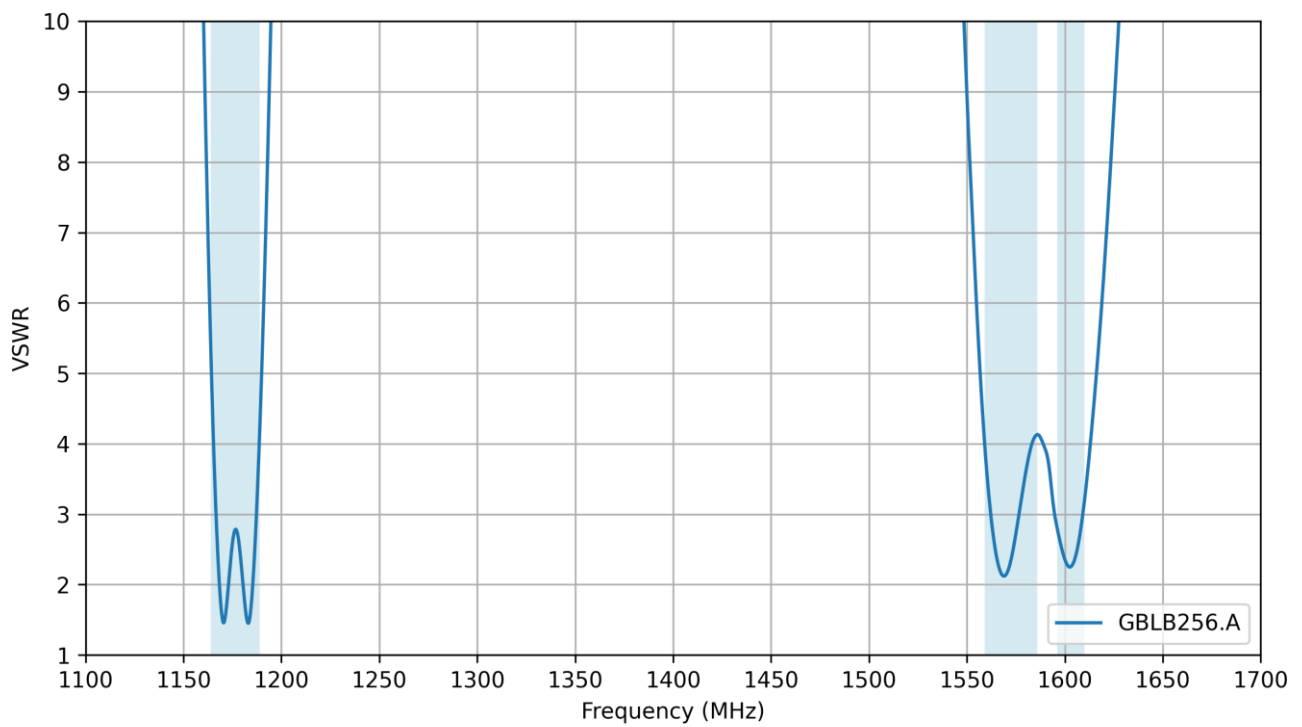

6.4 Efficiency

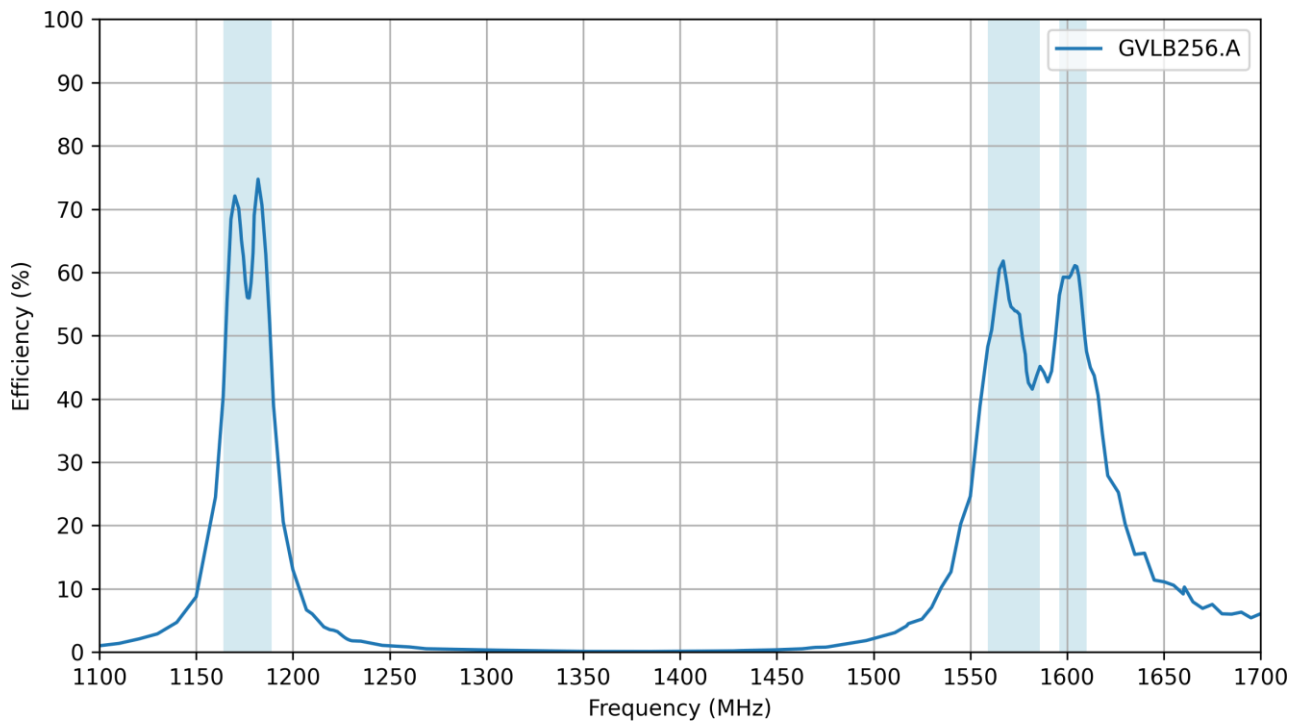

6.5 Average Gain

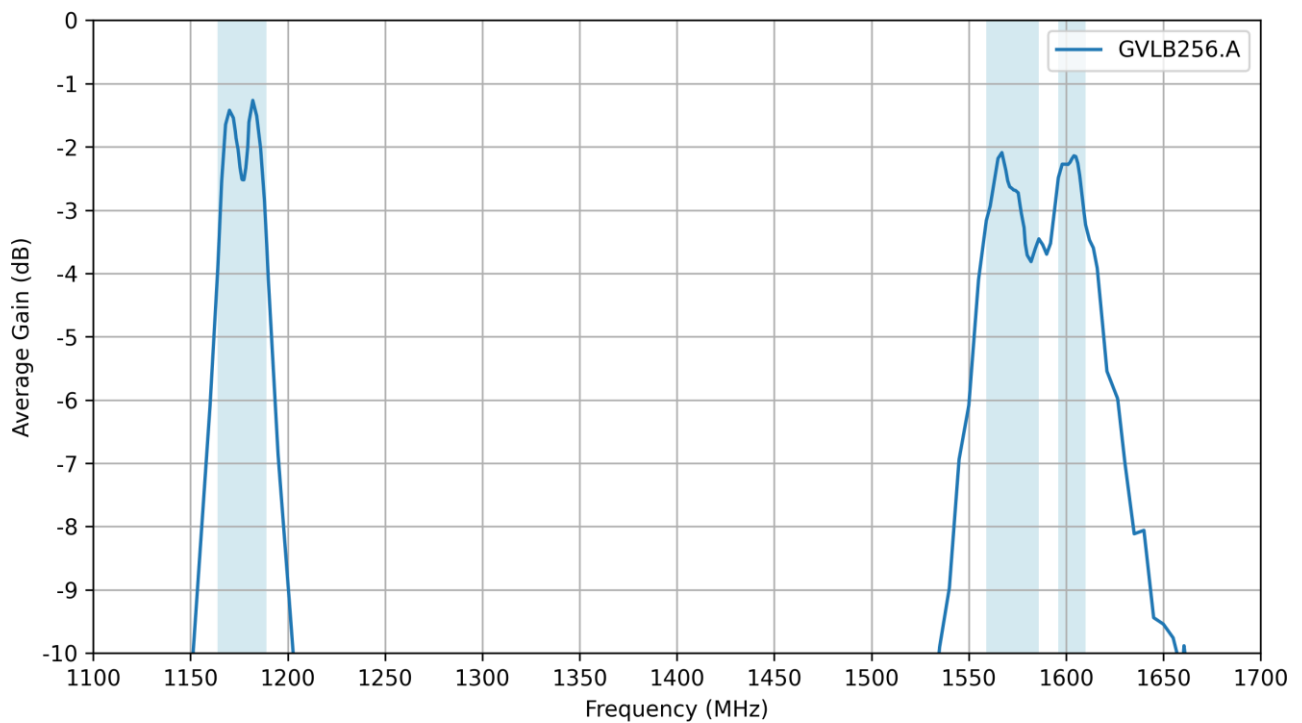

6.6 Peak Gain

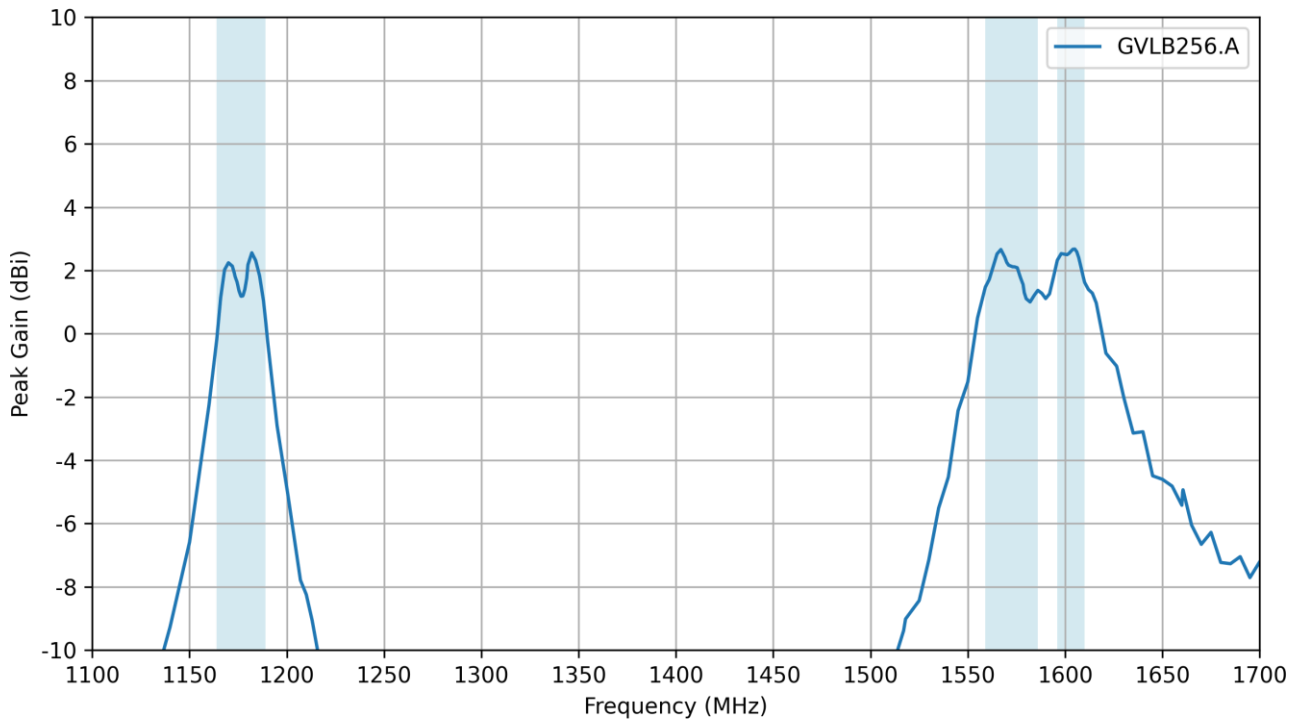

6.7 Axial Ratio

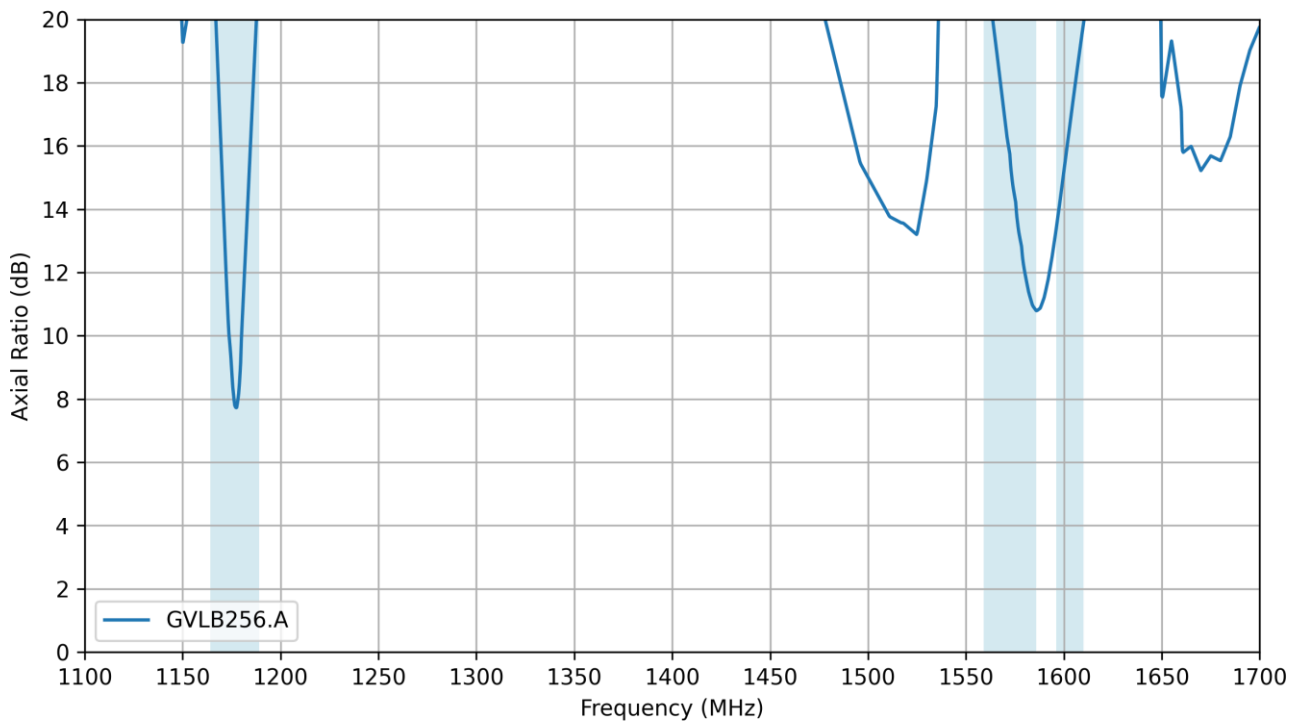

7. Radiation Patterns

7.1 Test Setup

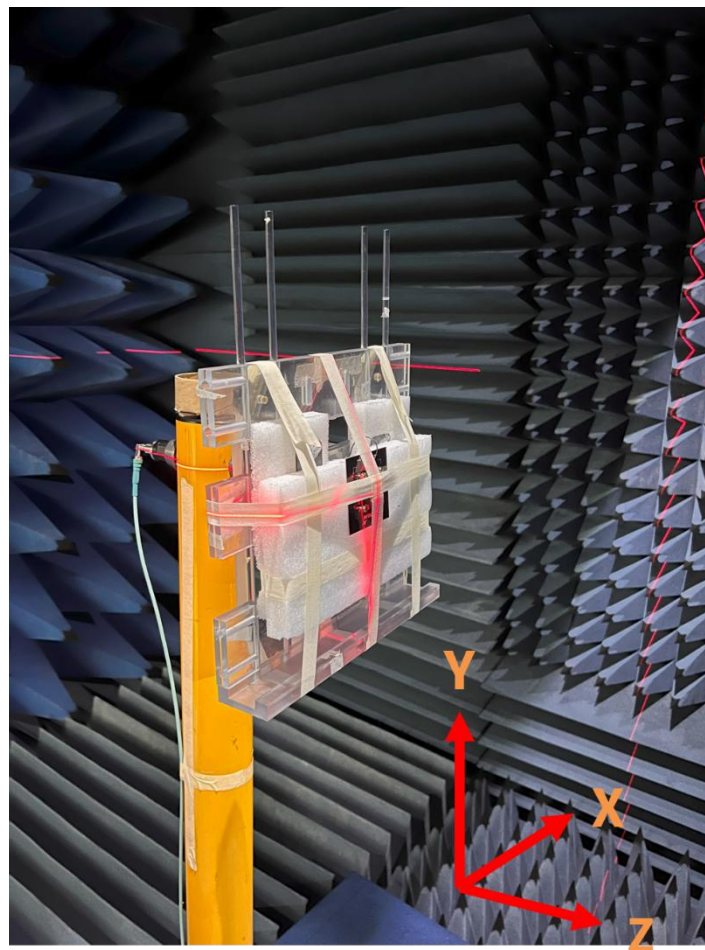
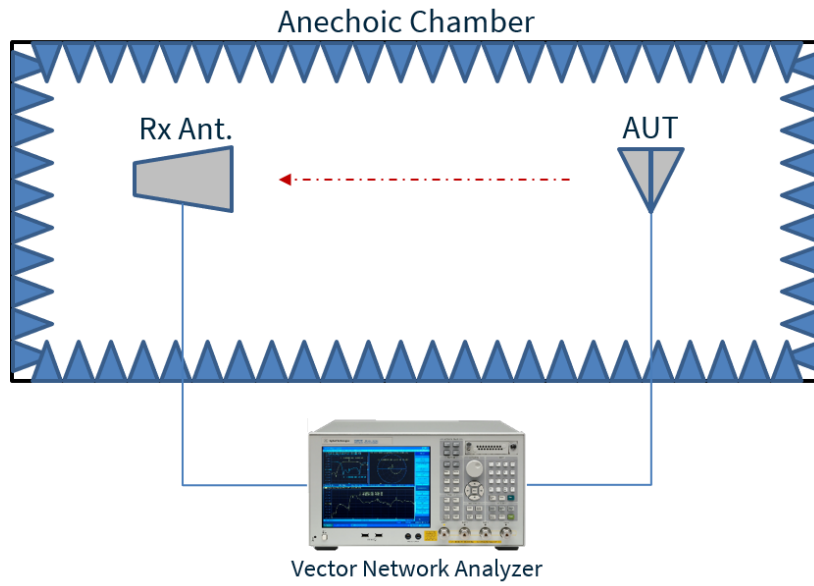

Chamber Test Set-up

7.2 Patterns at 1176 MHz

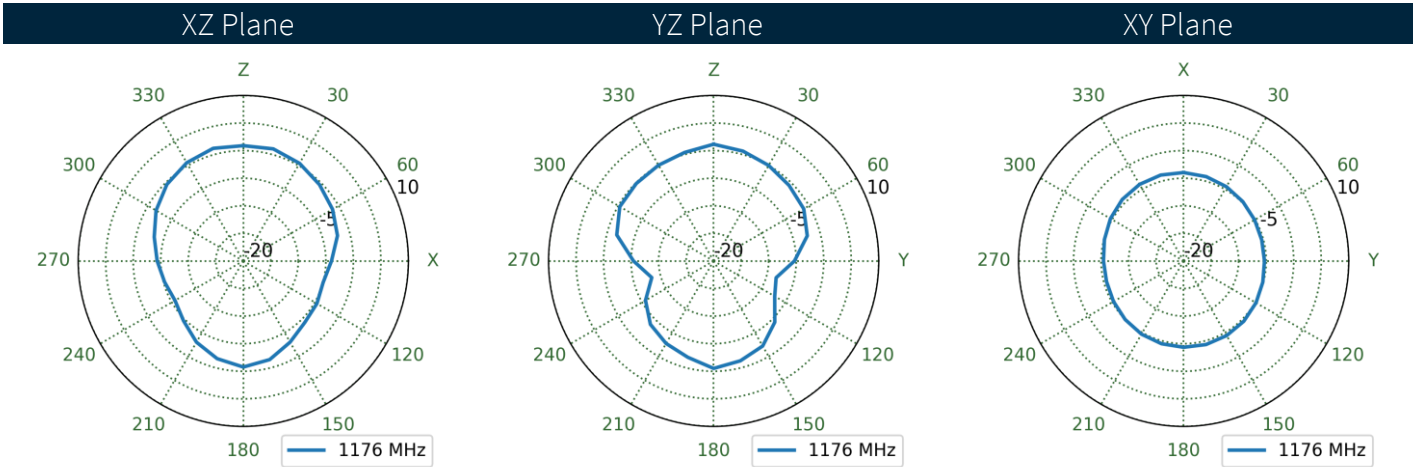
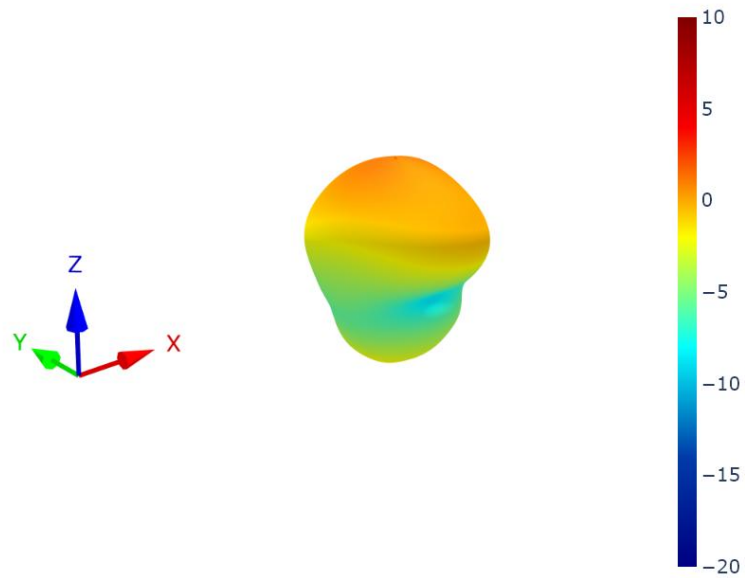

7.3 Patterns at 1561 MHz

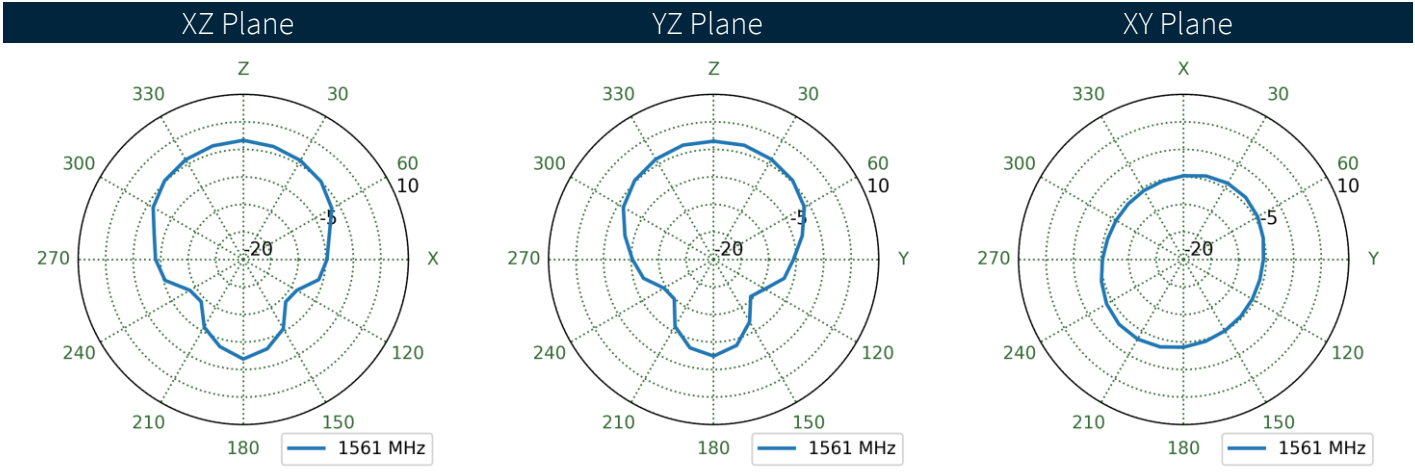
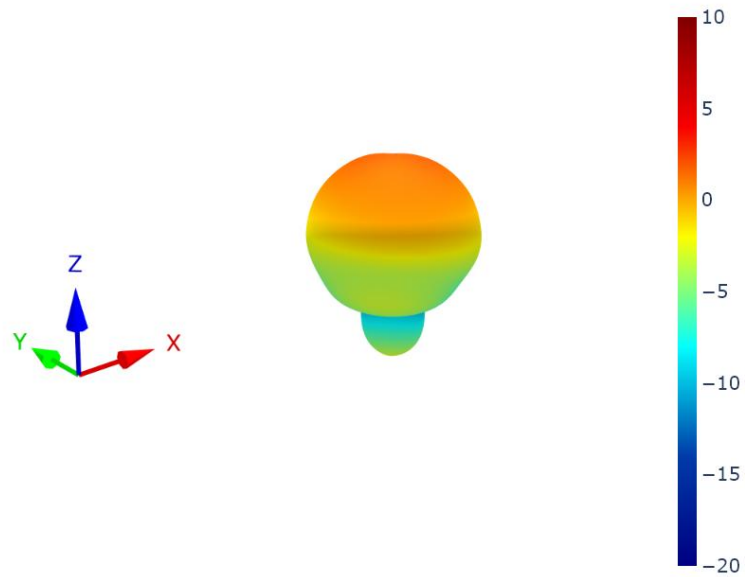

7.4 Patterns at 1575 MHz

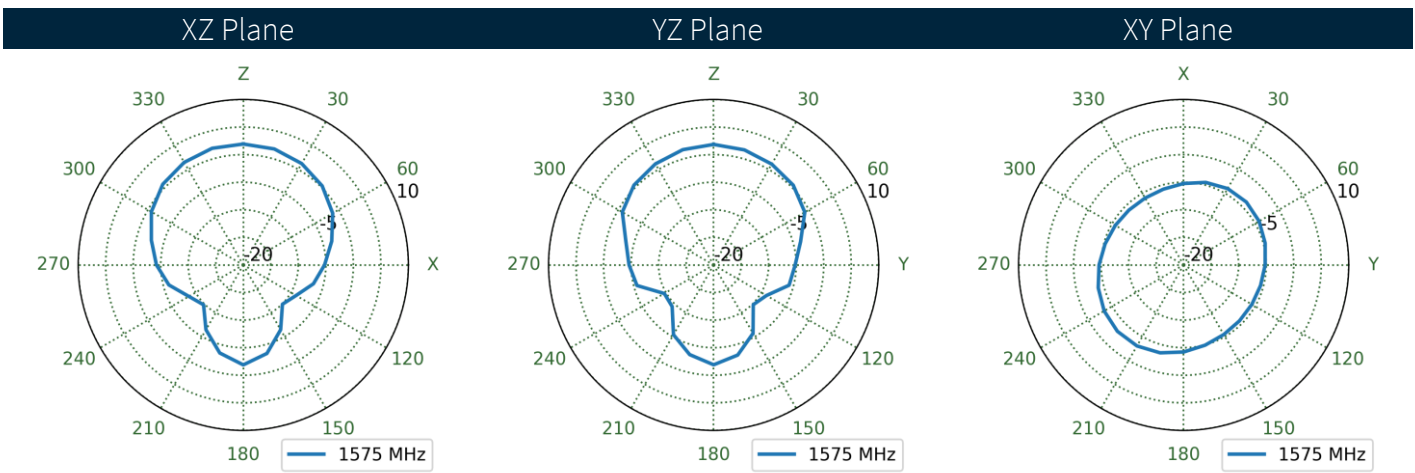
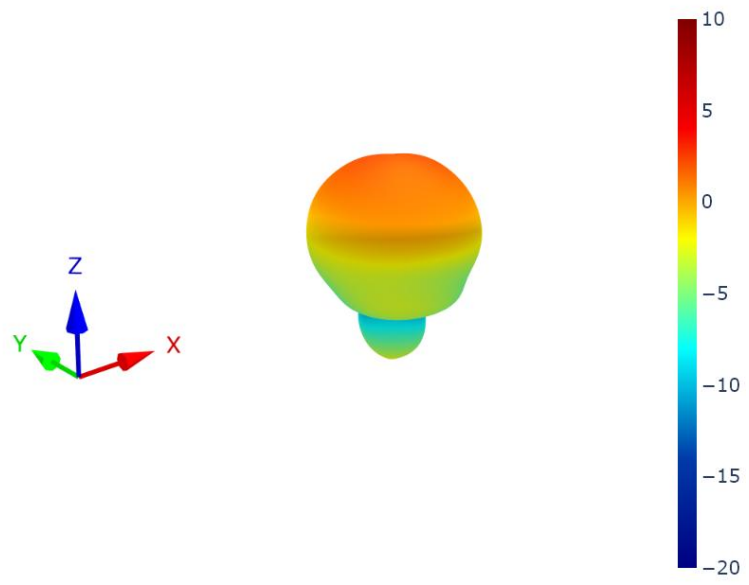

7.5 Patterns at 1603 MHz

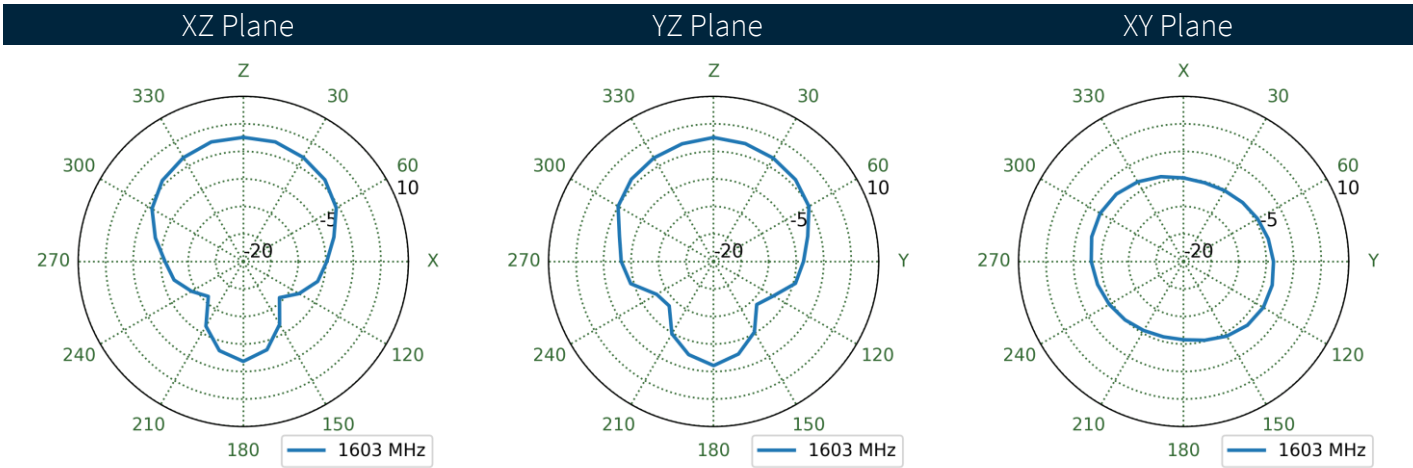
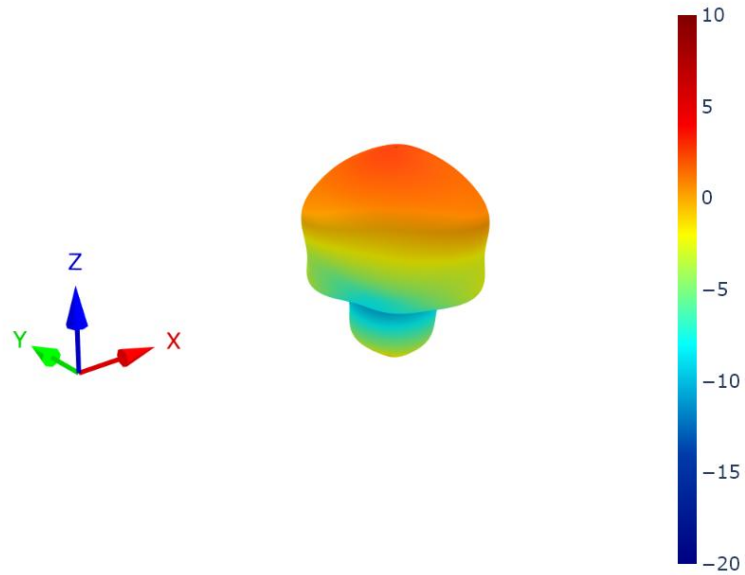

Changelog for the datasheet

SPE-25-8-086 – GVLB256.A

Revision: A (Original First Release)	
Date:	2025-03-18
Notes:	Initial Release
Author:	Gary West

Previous Revisions



www.taoglas.com

