

# Premium detection stability and optimal usability for Laser Displacement Sensors

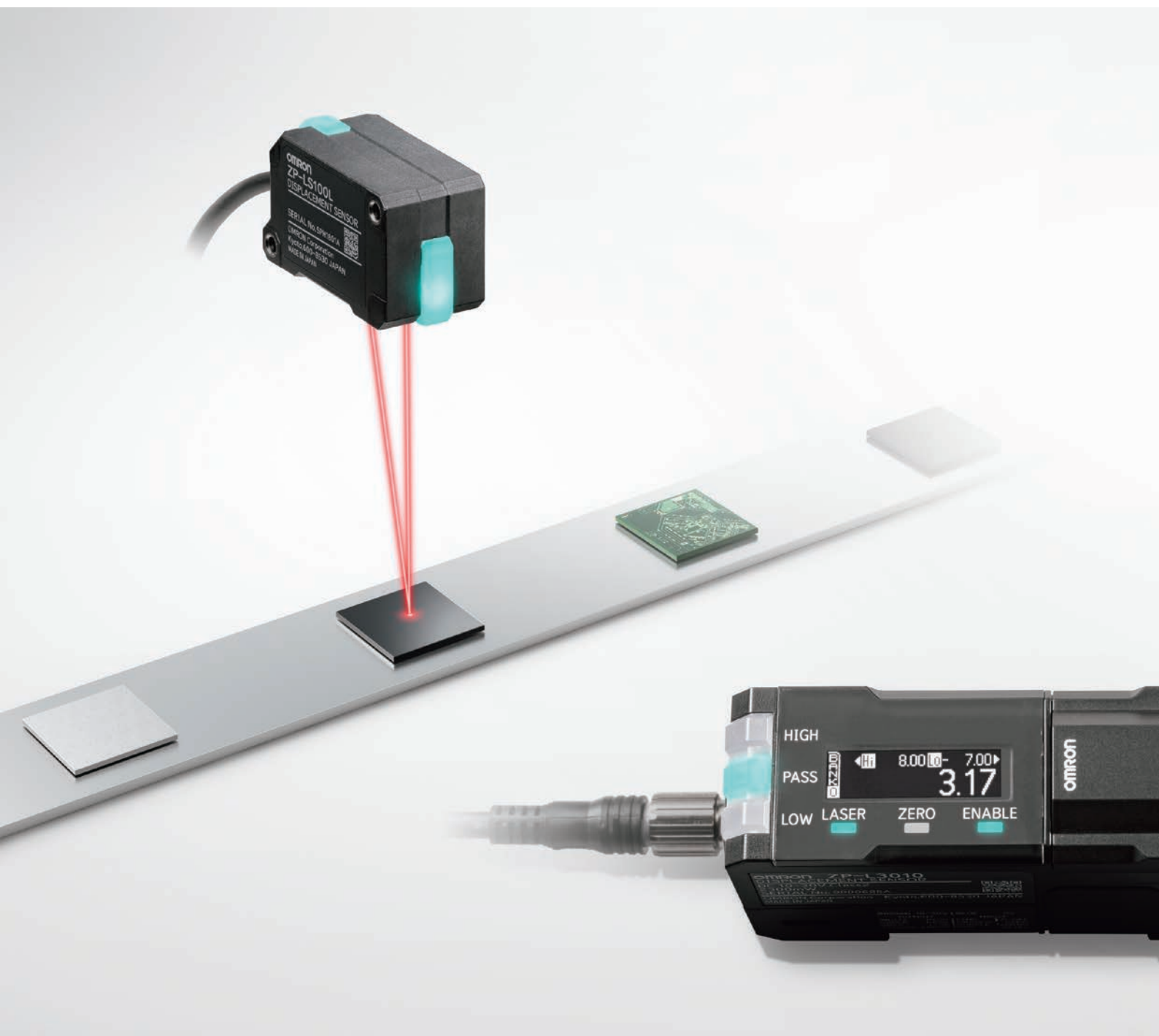

# For all engineers who don't have time for the hassle

We at OMRON believe that we are now at a time where laser displacement sensors should be selected for their usability.

Our new ZP-L Series products are equipped with a carefully designed user interface, as well as detection accuracy.

They're packed with creative features that allow engineers to cut back on time and effort unknowingly spent when working with displacement sensors.



## For inspection/detection of around 10 $\mu\text{m}$ to 1 mm

Detecting material remaining on roll

Checking for doubled-up boards

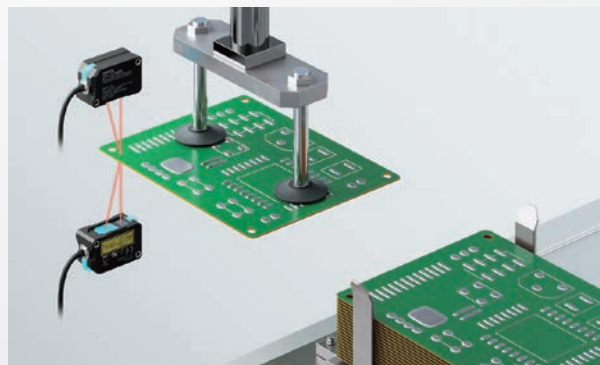

# Using displacement sensors is now easier with dramatically less effort

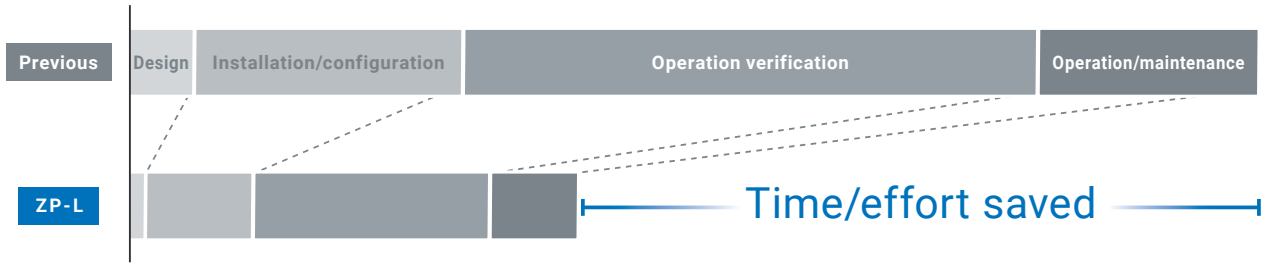

## Sensing performance delivering stable detection with initial configuration left intact P.4

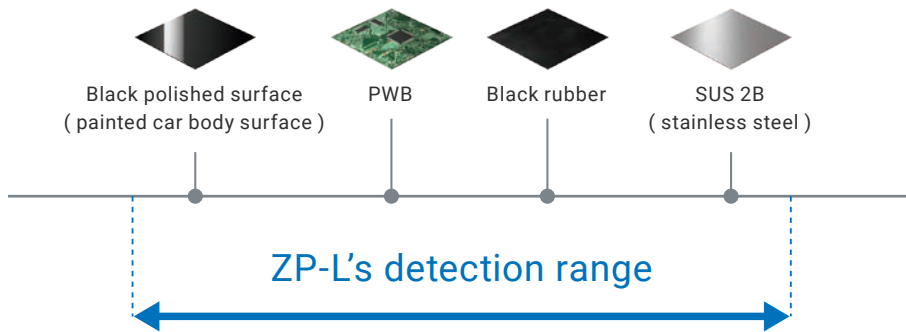

## User interface requiring no manuals for easy understanding P.6



## Support software allowing quick test without loggers P.8

Support software Wave Inspire ZP



# Sensing performance delivering stable detection with initial configuration left intact

## Different materials can be detected with the same configuration

ZP-L delivers a wide dynamic range<sup>\*1</sup> that delivers stable detection of a wide range of workpieces, from black polished workpieces (such as the painted surface of a car body), which reflect little light, to metal workpieces, which reflect a lot of light.

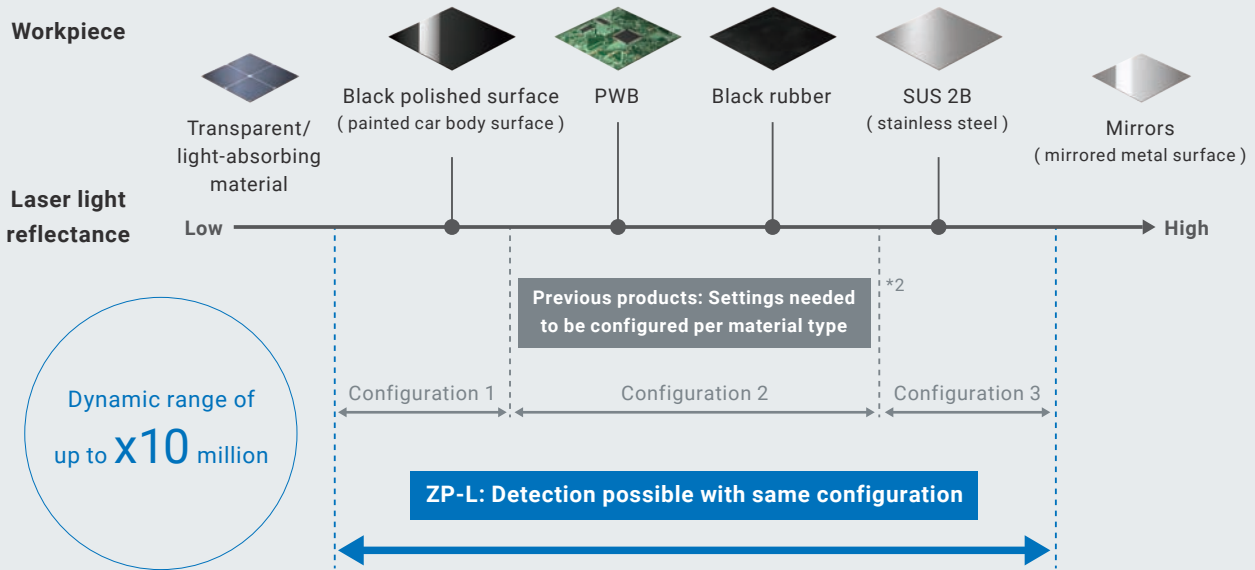

## Wide angle characteristic enables flexible installation

ZP-L has a wide angle characteristic, powered by its wide dynamic range and OMRON's unique sensing algorithms. It can measure an area of up to approximately 85°<sup>\*3</sup> allowing for flexible installation. For example, in cases where sensors cannot be installed directly above the target workpiece, ZP-L can be positioned diagonally and still deliver reliable measurement.

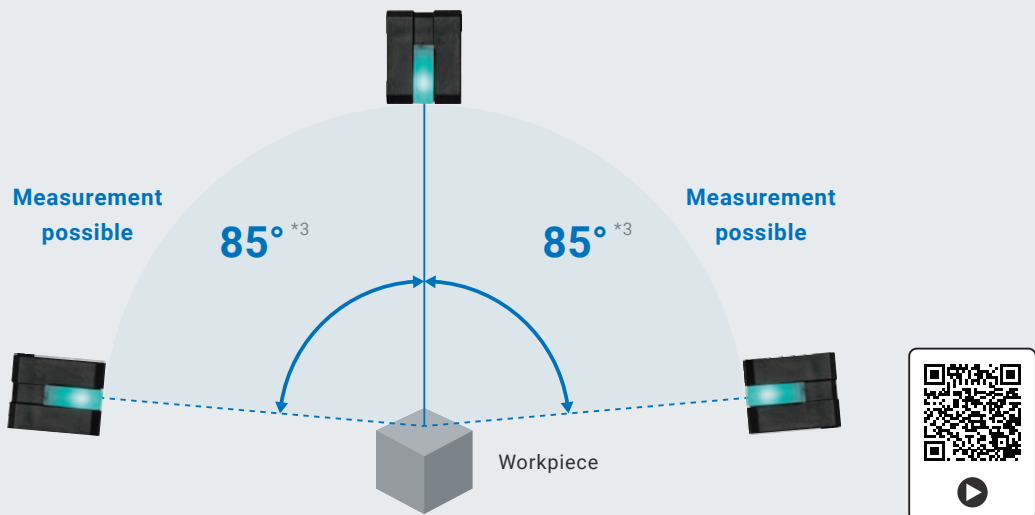

## Reliable best-of-class\*4 detection performance

When selecting or replacing your laser displacement sensors, be sure to check the following three performance attributes.

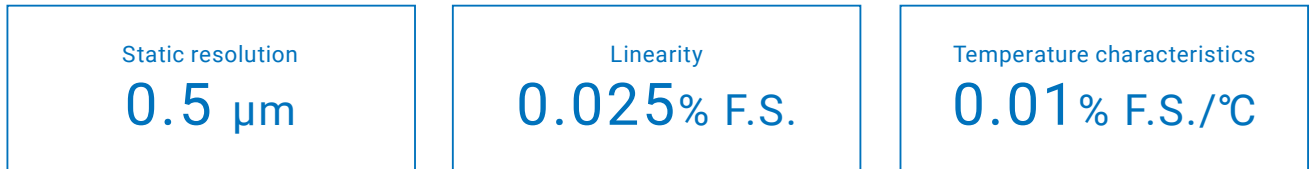

Note: Representative ZP-L Series performance values

## Reduces two types of variations: those in measurements made in motion and between individual sensor units

When measuring moving workpieces, laser displacement sensors, by their nature, are impacted by workpiece surface conditions, and variations in measurement values may exceed the resolution set forth in their specifications.

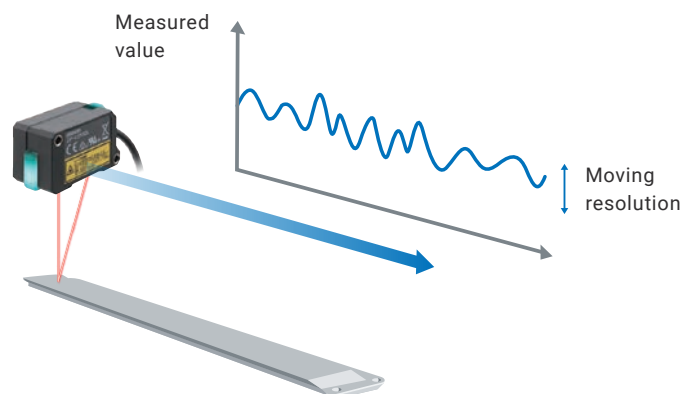

Measurement value variations in measurements made in motion  
( moving resolution ) [ μm ]

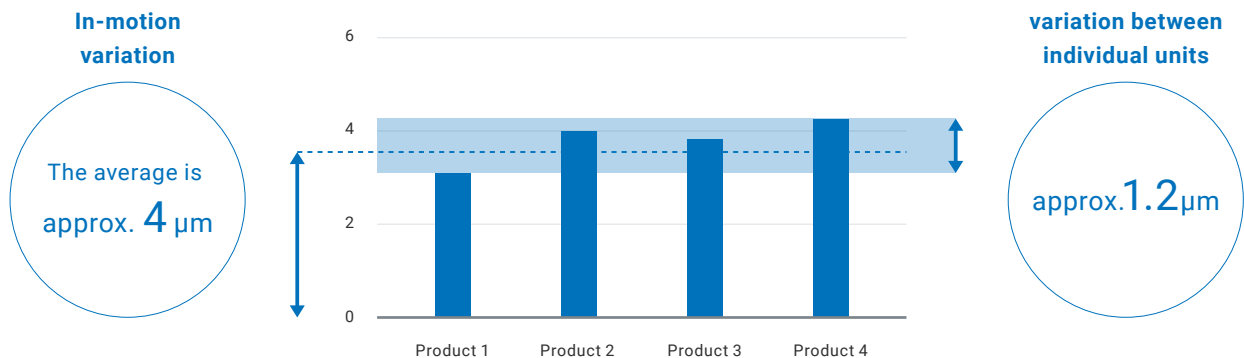

\*1. "Dynamic range" is a metric that indicates the range of detectable workpiece types, expressed as the ratio between the reflectance of the most reflective detectable workpiece and that of the least reflective detectable workpiece.  
 \*2. Compared with OMRON's ZX2 Series.  
 \*3. Representative example for workpieces with metal surfaces. Shape or material of measured object may impact measurement. Please check in advance using actual devices.  
 \*4. Best-performing in class of laser displacement sensors for detecting around 10 μm to 1 mm (according to OMRON investigation in November 2024).

# User interface requiring no manuals for easy understanding

## Easy-to-understand menu display

Amplifier units for previous laser displacement sensors used segment displays, which made it difficult for workers to know which item they were configuring without referencing their manuals. ZP-L amplifier units are equipped with OLED displays, which are capable of much richer presentation, allowing for easy-to-understand menu displays that save you the time of searching through your manuals for the right page.

### Previous displays

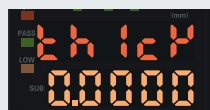
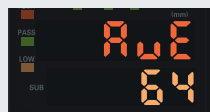

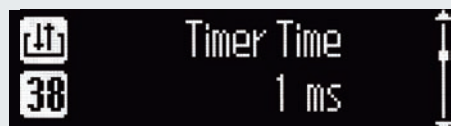
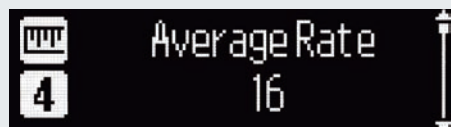
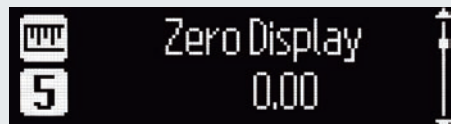

### ZP-L display

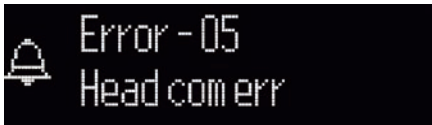

## Required action as well as error displayed in multiple languages PATENT PENDING <sup>\*1</sup>

ZP-L's display supports four languages, so that on-site workers at local factories can understand its configuration. Error displays have been carefully designed as well. The details of the error and the required action can be shown in different languages on the OLED display, allowing on-site first responders to take smooth action and enabling faster recovery.

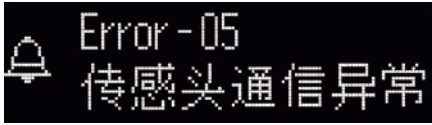
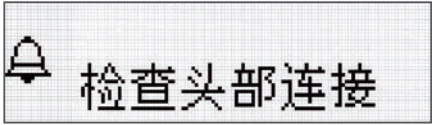
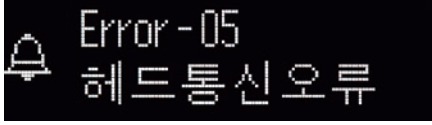
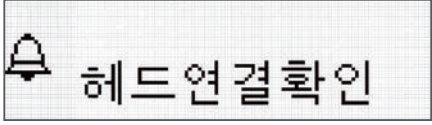
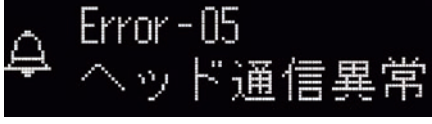
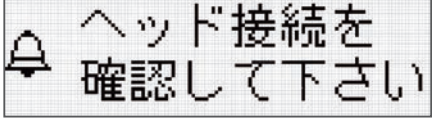
	Error details	Required action
English		
Chinese		
Korean		
Japanese		

## Intuitive screen design PATENTED <sup>\*1</sup>

The configuration screen is ingeniously designed to prevent users from losing track of where they are in their configuration process. Its layout, which works in coordination with button operation, allows for intuitive operation.

### Shows where you are in configuration process

Configuration item group displayed using icon and number

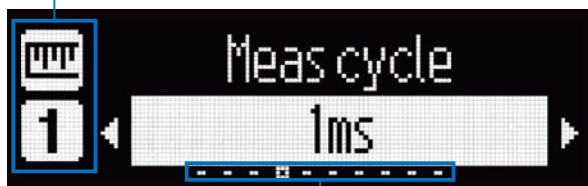

Pixel art icon indicates number of choices and which of them is currently displayed

### Guide linked to button positions

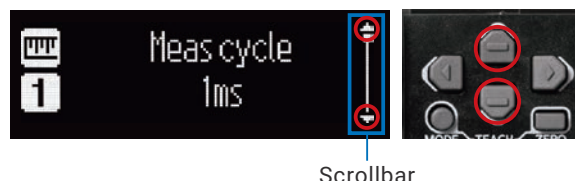

Scrollbar

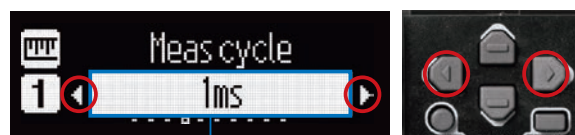

Field for setting value is highlighted

\*1. "Patent pending" and "Patented" refer to patent status in Japan (as of November 2024).

# Support software allowing quick test without loggers

## Operation/maintenance

### Sensor conditions can be checked without stopping equipment

With ZP-L, you can check sensor conditions without impacting the equipment's control operations, just by connecting the PC with the support software Wave Inspire ZP installed to the switching hub. There's no need for data loggers, or to program PLCs for operation checks. The support software Wave Inspire ZP can be downloaded for free. Please refer to the system configuration page in the data sheet for details.

#### Support software Wave Inspire ZP

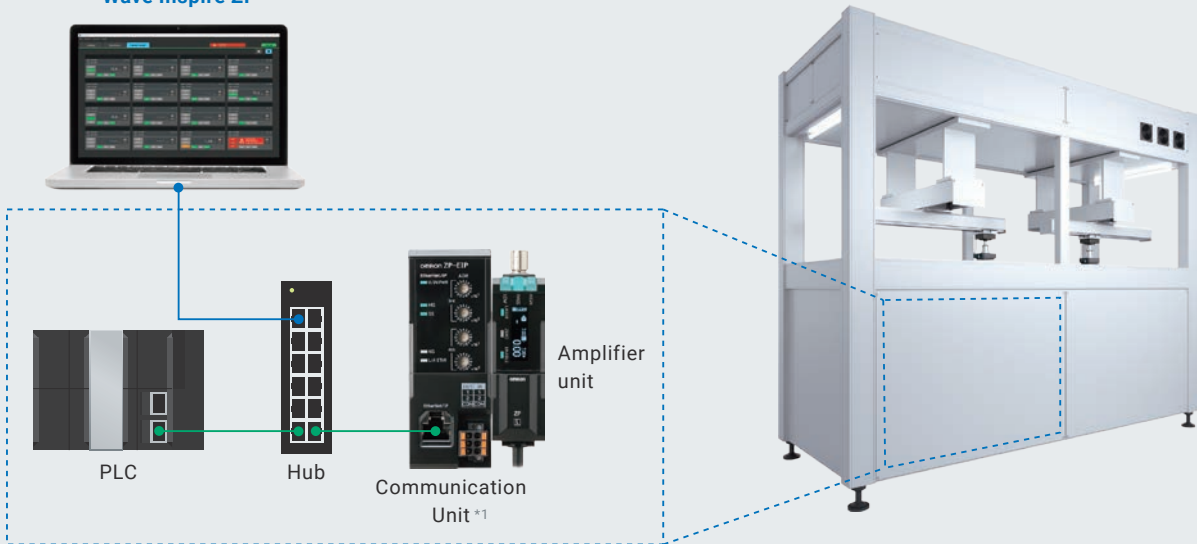

### Changes in configuration can be found and reversed quickly

**PATENT PENDING** \*2

Sensor configurations can be saved to the support software Wave Inspire ZP, which means you can compare your current sensor configuration with that at the time of setup. It also means that you can quickly find any changes that may have been made to your usual sensor configuration. Once you find the changes, you can reverse them with just a single click.

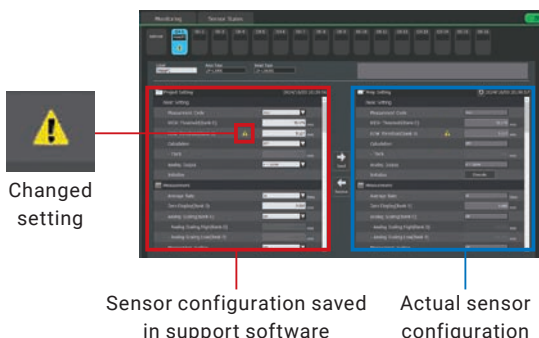

### No need to set the same configuration over and over again

You can copy the saved settings when replacing or expanding the amplifier unit at once.

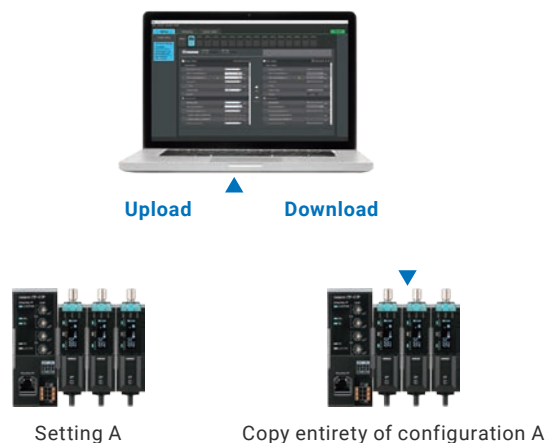

## Testing upon setup

# Measurement data can be visualized in just three minutes

Previously, testing upon setup required that measurement values be monitored using upper-level systems such as PLCs or tools such as data loggers, which took time and effort. With ZP-L, you can complete configuration and monitoring in just three minutes after connecting the sensor to the support software Wave Inspire ZP.

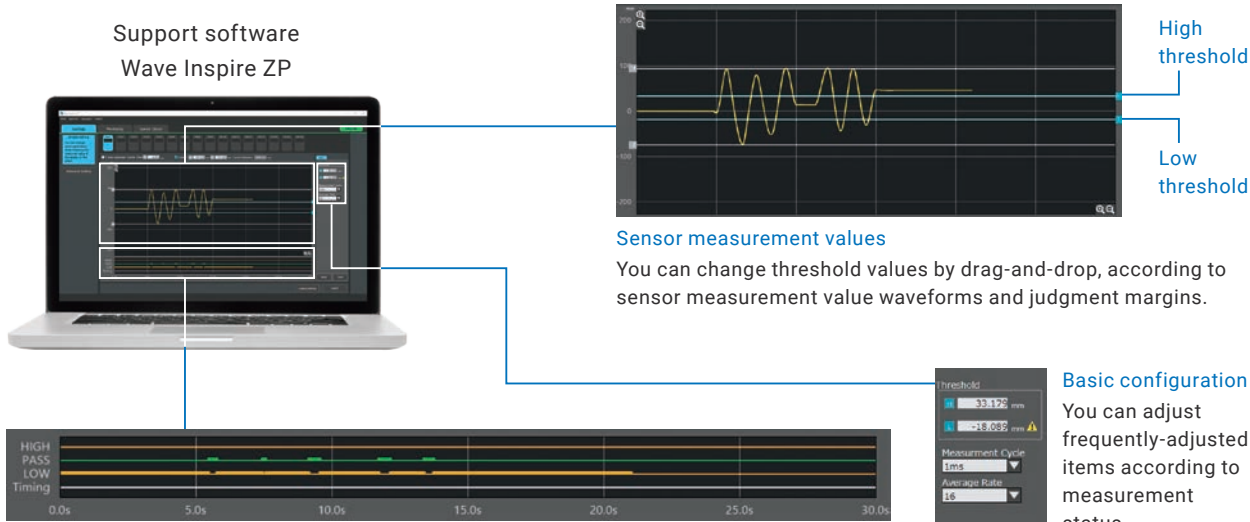

### Sensor input/output status

The input/output status of judgment results is visualized, along with measurement value waveforms, allowing you to literally see whether the results are as expected.

# Retrieved data is high-quality as well

Data for testing must be of high simultaneity and retrieved in high speed. ZP-L is equipped with a system that is meticulously designed to deliver high sensing simultaneity (3  $\mu$ s) and high-speed (1 ms) data retrieval.

## Simultaneity

PATENT PENDING \*2

ZP-L delivers high-quality data verification, even in cases using multiple sensor units. The timing of data measurement for all sensors connected to amplifiers is synchronized to within 3  $\mu$ s, allowing you to conduct verifications without worrying about timing deviations.

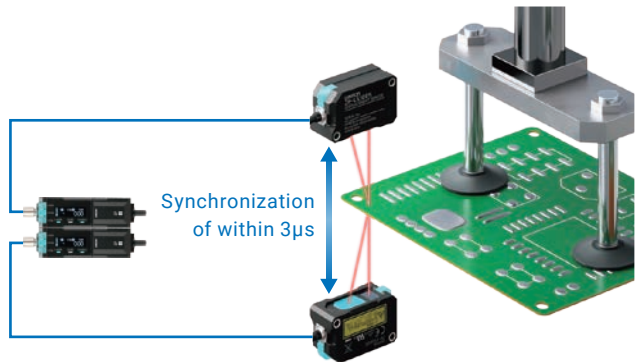

## Speed

PATENT PENDING \*2

ZP-L can also be used to verify high-velocity events. It can retrieve measurement values in 1-ms intervals, which can then be used to draw charts on your PC screen that closely depict actual equipment behavior.

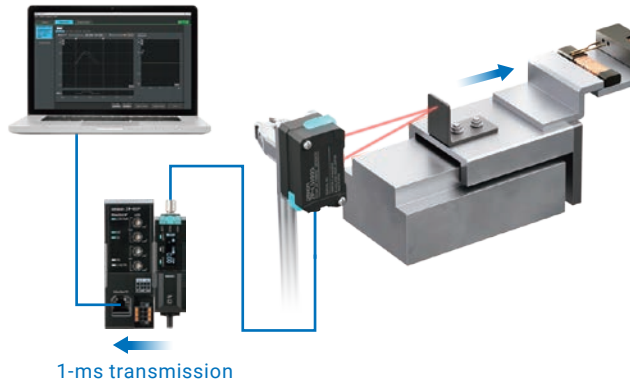

\*1. Communication unit ZP-EIP required for connection with PC.

\*2. "Patent pending" and "Patented" refer to patent status in Japan (as of November 2024).

# Carefully designed for on-site usability

## Smallest and lightest in its class,<sup>\*1</sup> and therefore easy to embed

Equipment is getting smaller, which means less space inside the equipment for sensor installation. With ZP-L, we were able to achieve our ambition to create a product that delivers both advanced accuracy and compact size, especially in the height direction, where space tends to be more restricted. The sensor head is also lighter, allowing for easier equipment rigidity design.

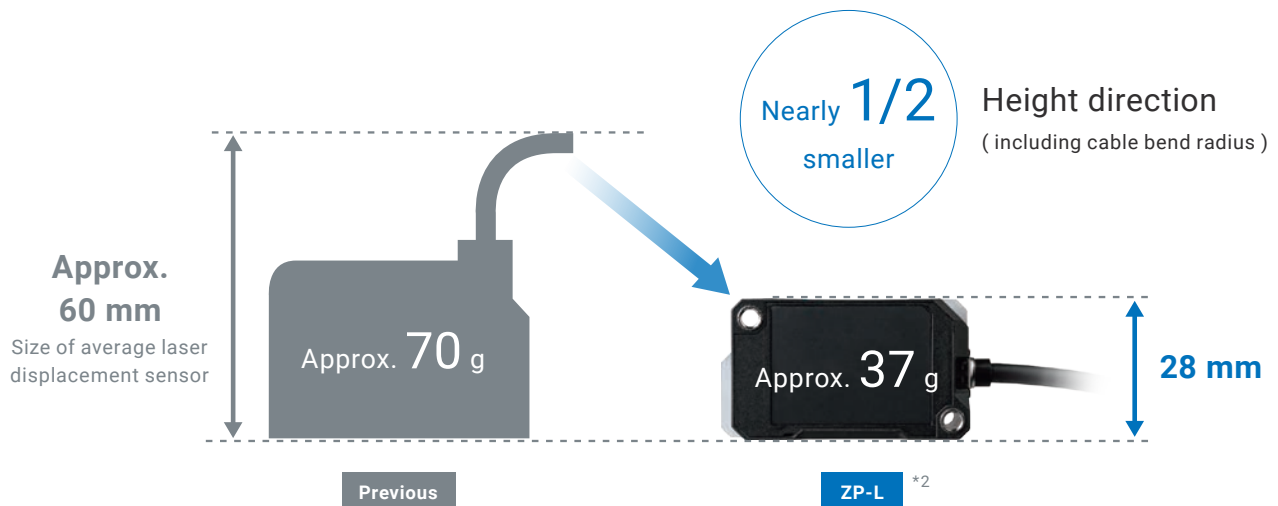

## Indicator lights easily visible from all directions

Large indicator lights in two locations (at top and back of senso head) easily visible from all directions.



## Find Me function for identifying sensor paired with amplifier unit

When an amplifier unit is switched to configuration mode, the indicator lights on the sensor head connected to it blinks in blue, making it easy to find, without the tedious task of tracing the cable.

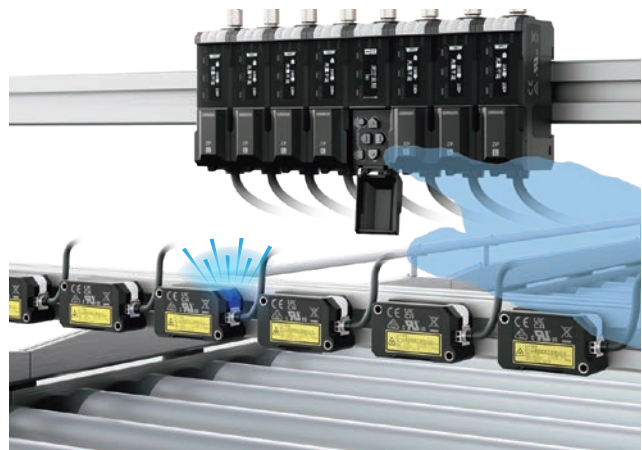

## Flexible mounting brackets that can be adjusted in three directions

Previous products required the effort-consuming task of designing and preparing brackets for mounting your sensors, and making fine optical axis adjustments when installing them. The ZP-L Series offers mounting brackets that allow you to easily make optical axis adjustments in three directions: height, horizontal, and angular.

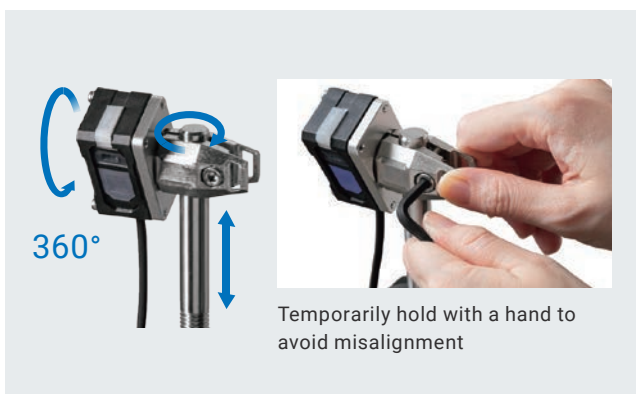

## Robot cables for moving parts

We offer highly bend-resistant extension robot cables for customers who need cables with high bend resistance. Our robot cables are perfect for moving parts of common machines such as cableveyors and loaders.

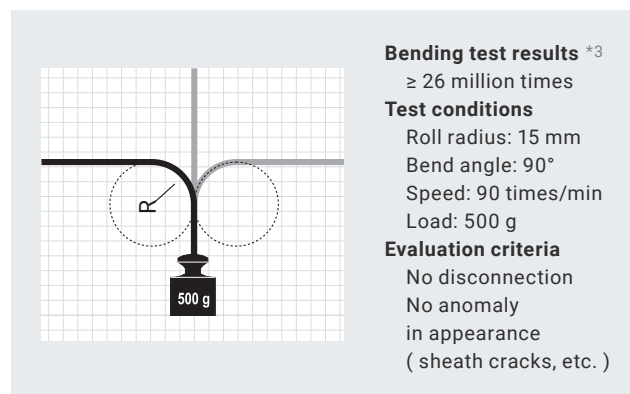

## Third-party certified for compliance with laser standards

ZP-L sensor heads have CB certification, a standard for lasers, which means that when you use them in your equipment, it doesn't need to be applied for laser certification.



## Slave amplifier units that reduce wiring

We offer slave amplifier units that help you reduce wiring when using multiple sensors. Power can be supplied from the master unit, which means slave units don't need to be wired for power. You can also save cable termination effort by using slave units without cables for units that don't output judgment.

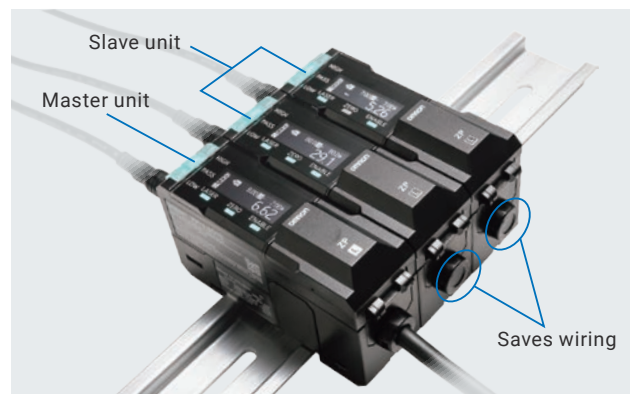

\*1. Best-performing in class of laser displacement sensors for detecting around 10 μm to 1 mm (according to OMRON investigation in November 2024).

\*2. In case of ZP-LS025/-LS050/-LS100.

\*3. Test results are from tests conducted by OMRON and should be used only as reference information, not as guaranteed values when using products in actual customer settings and conditions thereof.

# 4 technologies powering ZP-L's best-in-class performance<sup>\*1</sup>

## Custom CMOS image sensor designed to deliver maximum sensing performance

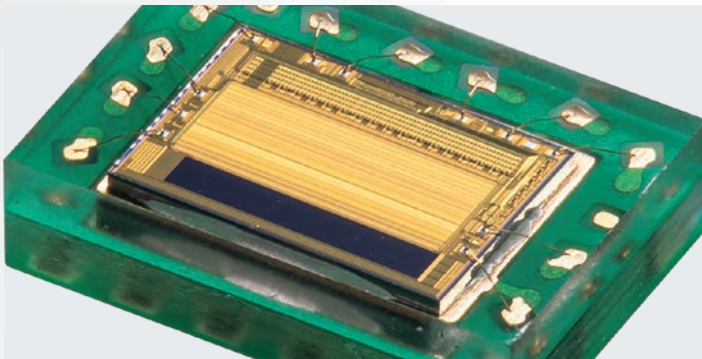

In developing ZP-L, OMRON took a deep dive into the internal structure and production process of CMOS image sensors to custom-develop high-speed, high-sensitivity, low-noise CMOS image sensors that maximize performance.

Custom CMOS image sensor

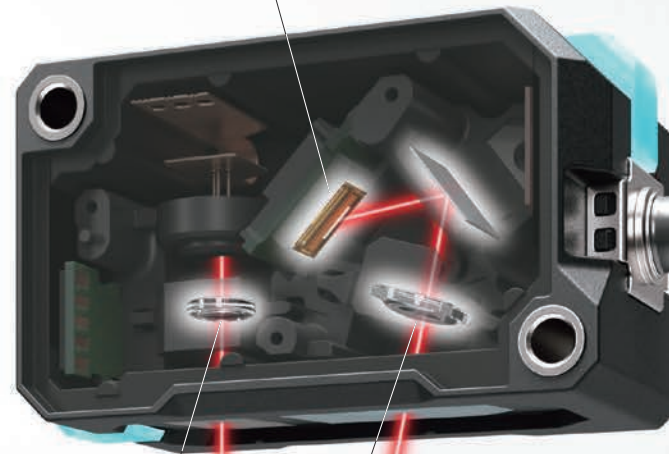

1 μm-level lens positioning

## Unique manufacturing methods that reduce variations between individual units **PATENTED**<sup>\*2</sup>

Automatic three-axis adjustment mechanism

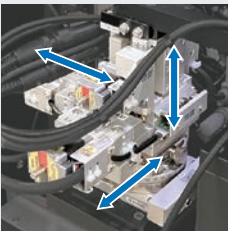

Technology for accurate adjustment

Flexible fixing mechanism using dam structure

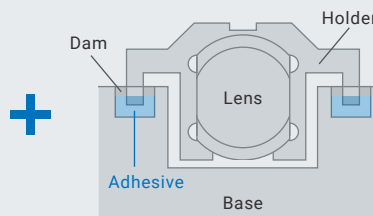

Technology for accurate component fixing

OMRON successfully developed and applied unique technologies that deliver micrometer-level automatic lens adjustment and nanometer-level fixing in the ZP-L production process. Together, these technologies minimize variations in adjustment and assembly, thereby reducing variations in performance between individual sensor units.

## Unique adhesive sealing technology that enables downsizing

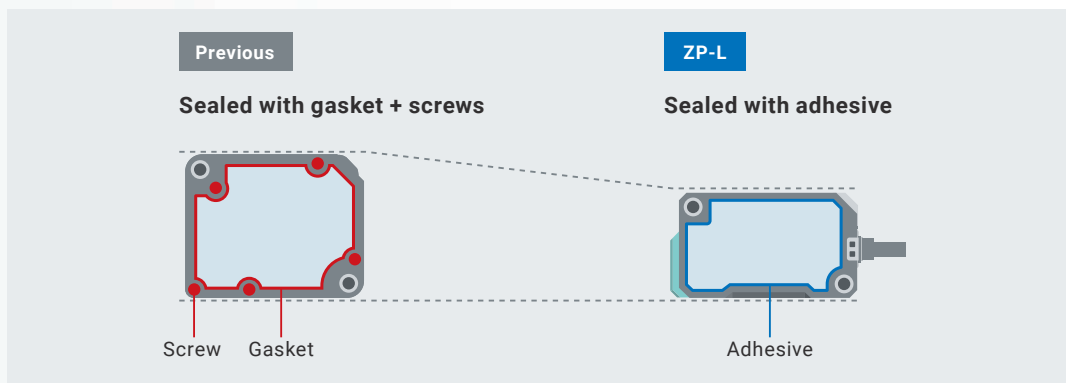

As a general rule, improving sensor accuracy means using larger optical components, such as lenses and CMOS image sensors. This creates a trade-off between improving accuracy and reducing size. To resolve this dilemma, ZP-L uses a sealing technology using adhesives, which, compared to more conventional sealing methods using screws and gaskets, allows for more efficient use of chassis space. It is thanks to this technology that ZP-L is able to deliver high accuracy while having the smallest chassis in its class.

## Sensing algorithm for stable sensing, of different materials and in tilted positions

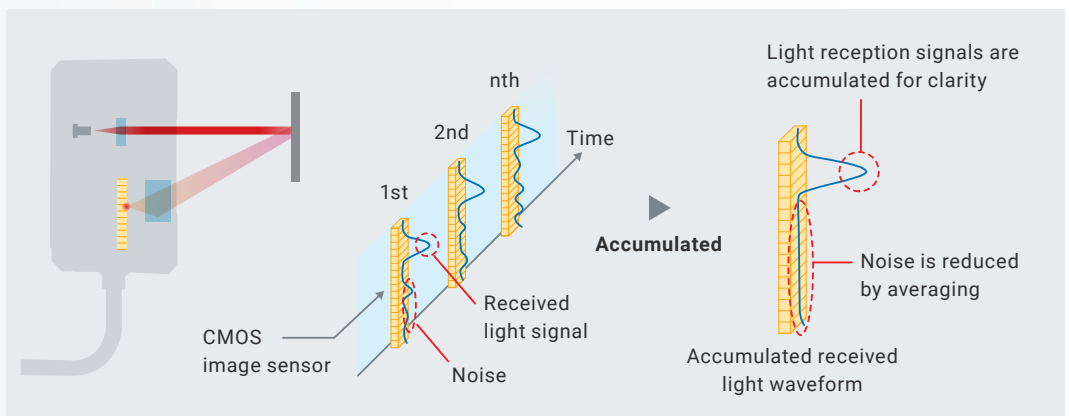

ZP-L delivers significantly higher sensitivity compared to previous products, through its unique process of integrating received light waveforms. This process amplifies the slightest light, allowing for stable detection even when the head is installed in a tilted position.

\*1. Best-performing in class of laser displacement sensors for detecting around 10  $\mu\text{m}$  to 1 mm (according to OMRON investigation in November 2024).

\*2. "Patent pending" and "Patented" refer to patent status in Japan (as of November 2024).

ZP-L can be used to determine positions and to measure heights/thicknesses of around 10  $\mu\text{m}$  to 1 mm

## Height/Thickness

Detecting material remaining on roll

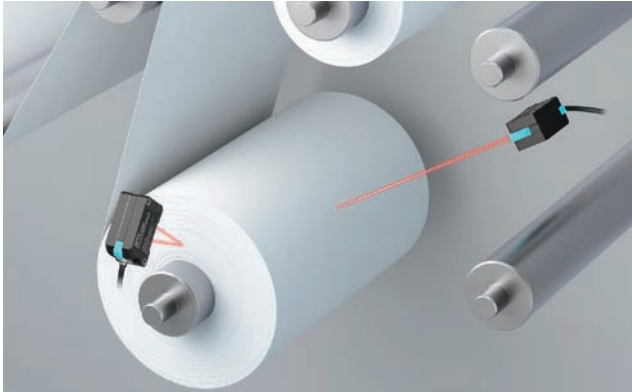

Measuring component heights

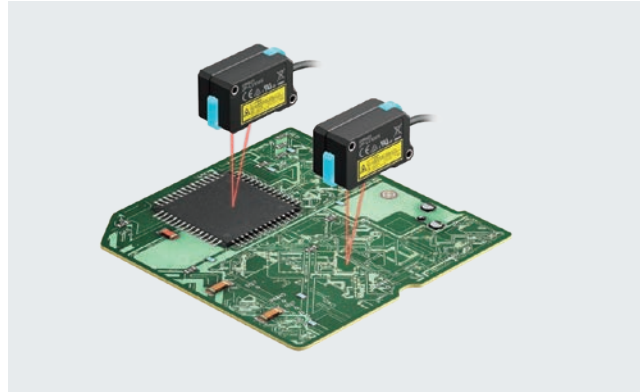

Monitoring trends in warp amount

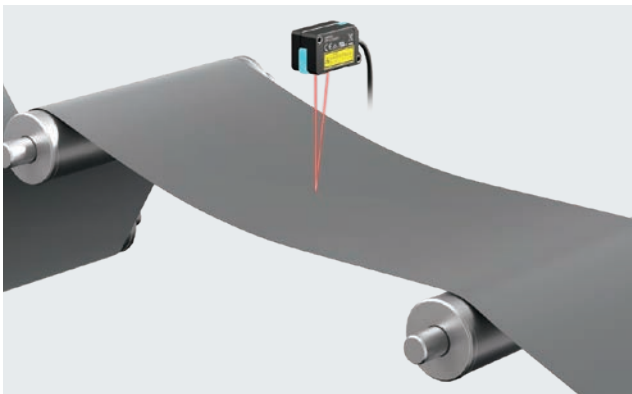

Determining whether part is present



## Positioning/Control

Robot hand positioning

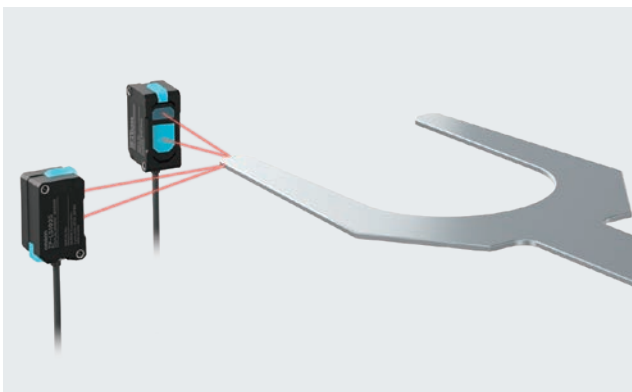

Nozzle height control

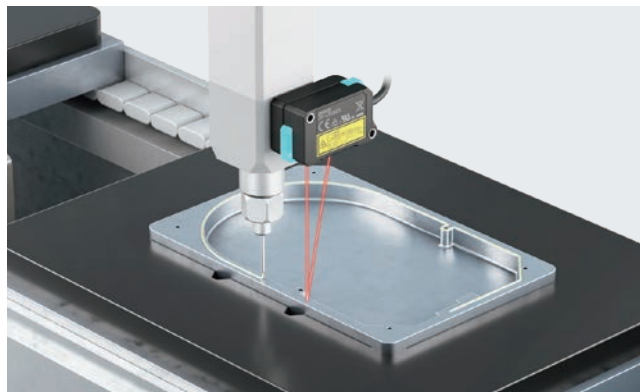

## Shape/Curves

Shape inspection of metal part

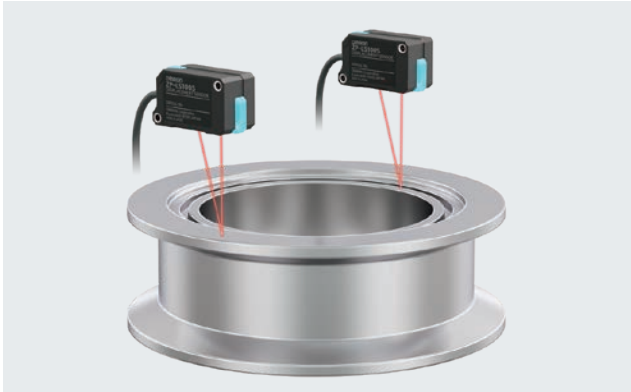

Flatness measurement/inspection

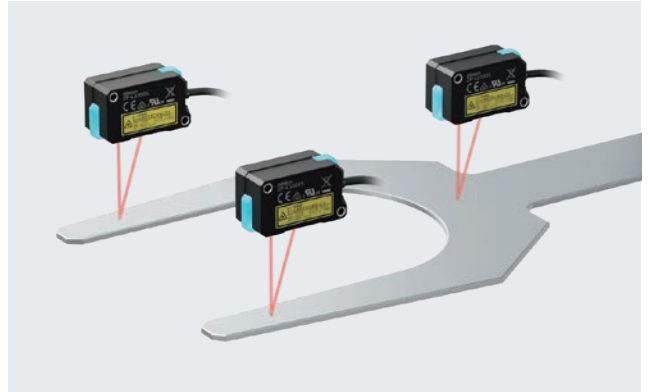

## Stroke/Deflection

Press stroke management



Tire eccentricity inspection

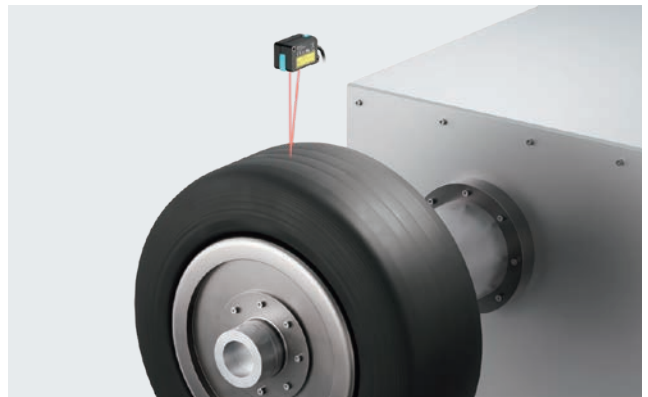

## Joints/Counting

Detecting joints in welding

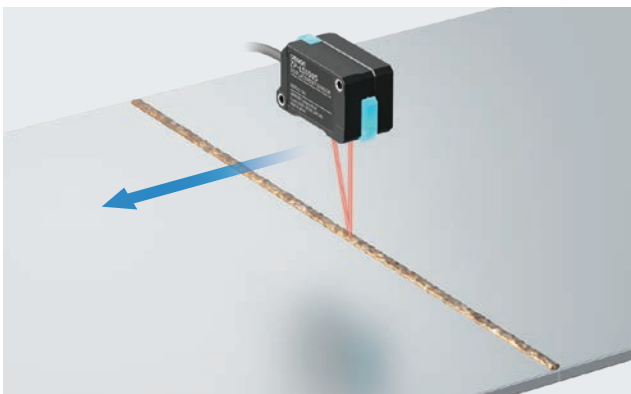

Counting number of trays



# Laser Displacement Sensor ZP-L

## Premium detection stability and optimal usability for Laser Displacement Sensors

- Sensing performance delivering stable detection with initial configuration left intact
- User interface requiring no manuals for easy understanding
- Support software allowing quick test without loggers



For the most recent information on models that have been certified for safety standards, refer to your OMRON website.

## System configuration

### Basic configuration

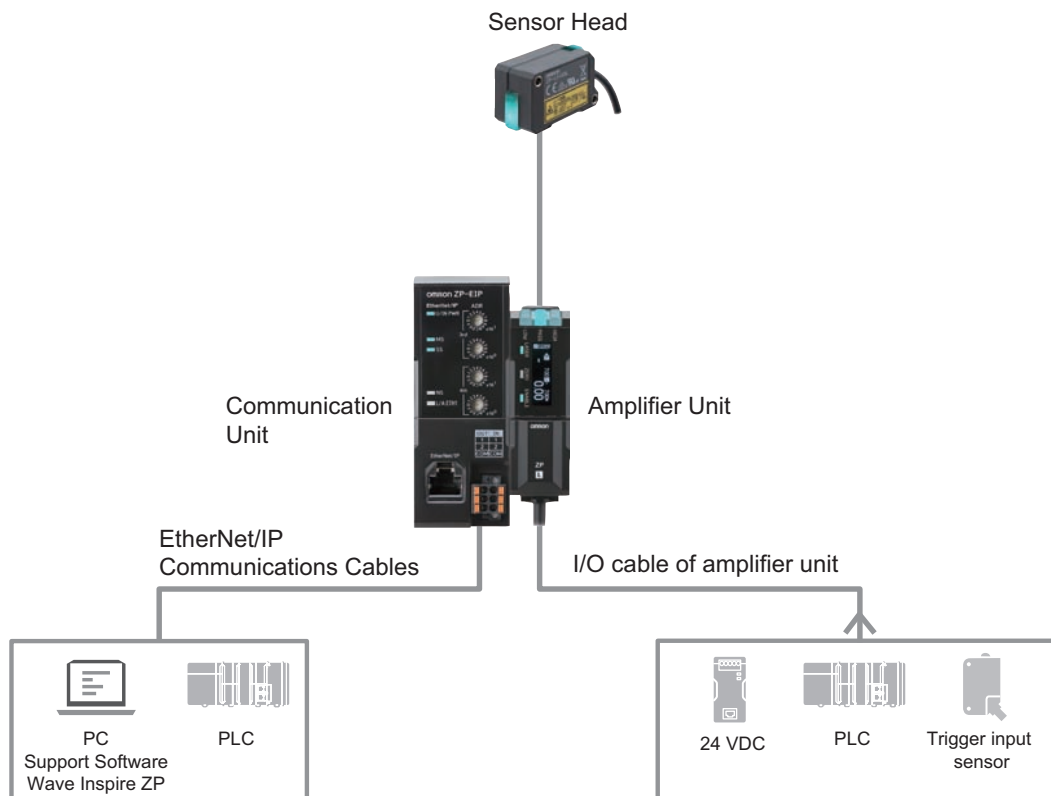

Product	Description
Sensor Head	We offer an extensive lineup from which you can select your product based on measurement distance, beam shape, and resolution.
Amplifier Unit	One amplifier unit is required for each sensor head.
Communication Unit	Required for communication with PC/PLC.
EtherNet/IP Communications Cables	Required for connection with PC/PLC.
Support Software Wave Inspire ZP	Download free from below URL. <a href="https://www.ia.omron.com/zp_tool">https://www.ia.omron.com/zp_tool</a>

## Configuration with multiple units connected

We offer two lines of amplifier unit products: master units and slave units. When using several sensor units, use them with slave units to save costs and wiring. Up to 16 amplifier units can be connected together (one master unit, 15 slave units).

When having judgment output from each amplifier unit  
 1 master unit,  
 N slave units (models with input/output: ZP-L3510/-L3560)

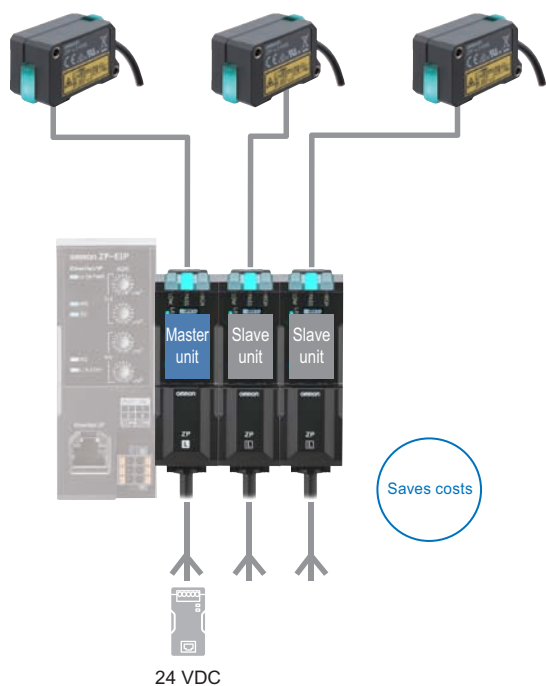

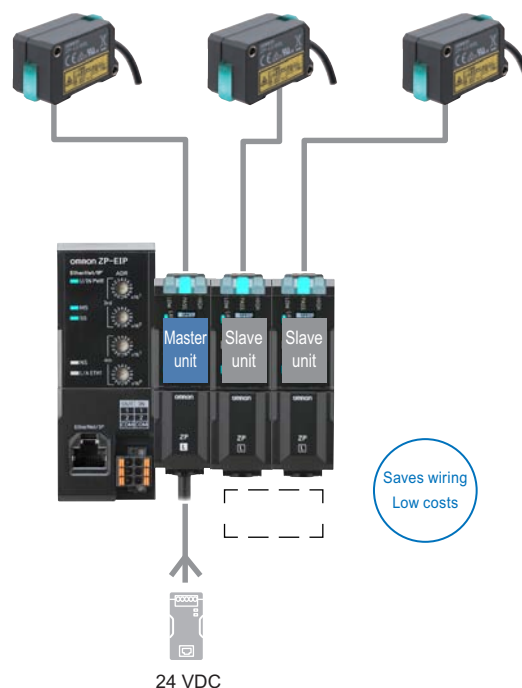

When retrieving measurement values using communication unit  
 1 master unit,  
 N slave units (model without input/output: ZP-L3590)



Product	Description
Amplifier unit master unit	First amplifier unit must be master unit. Power supply is connected to master unit only.
Amplifier unit slave unit	Up to 15 units can be connected. There are two types of units: those with input/output and those without input/output.
Communication Unit	Use as needed.

# Ordering Information

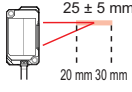
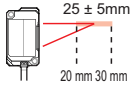
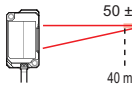
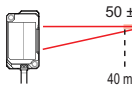
## Sensor Head

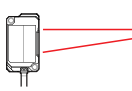
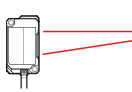
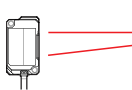
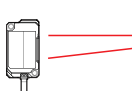
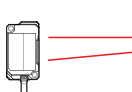
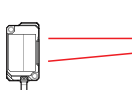
Appearance	Optical system	Beam shape	Measurement distance	Resolution *	Cable length	Model
	Diffuse-reflective	Line beam		0.5 μm	0.2 m	ZP-LS025L 0.2M
					2 m	ZP-LS025L 2M
		Spot beam		0.6 μm	0.2 m	ZP-LS025S 0.2M
					2 m	ZP-LS025S 2M
		Line beam		0.7 μm	0.2 m	ZP-LS050L 0.2M
					2 m	ZP-LS050L 2M
Spot beam		0.8 μm	0.2 m	ZP-LS050S 0.2M		
			2 m	ZP-LS050S 2M		
	Diffuse-reflective	Line beam		1.2 μm	0.2 m	ZP-LS100L 0.2M
					2 m	ZP-LS100L 2M
		Spot beam		1.3 μm	0.2 m	ZP-LS100S 0.2M
					2 m	ZP-LS100S 2M
		Line beam		4 μm	0.2 m	ZP-LS300L 0.2M
					2 m	ZP-LS300L 2M
Spot beam		4 μm	0.2 m	ZP-LS300S 0.2M		
			2 m	ZP-LS300S 2M		
Line beam		14 μm	0.2 m	ZP-LS600L 0.2M		
			2 m	ZP-LS600L 2M		
Spot beam		14 μm	0.2 m	ZP-LS600S 0.2M		
			2 m	ZP-LS600S 2M		



\* This shows the width of the variation of measured values when OMRON's standard target (white diffuse object) is measured at a reference distance with a measurement cycle of 1 ms and an average rate of 128 times.

**Note:** Sensor heads listed on this data sheet use class 2 lasers, but we offer products with class 1 lasers as well, the model names of which end with the letter "C" followed by cable length (example: ZP-LS025LC 2M).



Using different beam shapes

## Amplifier Unit

Appearance	Master/Slave *1	Analog output	Judgment output *2	External input *3	Input/output type	Model
	Master unit	Yes	Yes	Yes	NPN	ZP-L3000
					PNP	ZP-L3050
		No	Yes	Yes	NPN	ZP-L3010
					PNP	ZP-L3060
	Slave unit	No	Yes	Yes	NPN	ZP-L3510
					PNP	ZP-L3560
	Slave unit	No	No	No	—	ZP-L3590

\*1. First amplifier unit must be master unit.

In a system with multiple amplifier units connected together, there can only be one master unit.

Power supply connection is required for master unit only. All power supplied to slave and communication units is supplied from master unit.

\*2. HIGH/PASS/LOW

\*3. Zero reset, LD-off, timing, reset, bank

## Communication Unit

Appearance	Communication type	Connected devices	Model
	EtherNet/IP™ No-protocol (TCP)	PLCs and PCs from different manufacturers	ZP-EIP

To use support software Wave Inspire ZP connect your sensor to your PC using the communication unit.

Wave Inspire ZP can be downloaded for free from the URL below.

[https://www.ia.omron.com/zp\\_tool](https://www.ia.omron.com/zp_tool)

Wave Inspire ZP is a setup support tool. Please note the following before use.









- (1) OMRON assumes no responsibility for damage caused by any malfunctioning of this software, whether directly or indirectly, or caused by the effects of such malfunctioning.
- (2) OMRON assumes no responsibility for any damage incurred by the customer due to use of this software.



How to connect amplifier units and communication units

**Accessories (sold separately)**

**Sensor head - amplifier unit extension cable**











Cable specifications	Cable connection direction	Assembly tutorial video	Cable length	Model
Normal cable	Amplifier unit side: Straight Sensor head side: Straight		1 m	XS3W-M421-401-R
			2 m	XS3W-M421-402-R
			5 m	XS3W-M421-405-R
			10 m	XS3W-M421-410-R
			20 m	XS3W-M421-420-R
	Amplifier unit side: L-shaped Sensor head side: L-shaped		1 m	XS3W-M422-401-R
			2 m	XS3W-M422-402-R
			5 m	XS3W-M422-405-R
			10 m	XS3W-M422-410-R
			20 m	XS3W-M422-420-R
	Amplifier unit side: Straight Sensor head side: L-shaped		1 m	XS3W-M423-401-R
			2 m	XS3W-M423-402-R
			5 m	XS3W-M423-405-R
			10 m	XS3W-M423-410-R
			20 m	XS3W-M423-420-R
	Amplifier unit side: L-shaped Sensor head side: Straight		1 m	XS3W-M424-401-R
			2 m	XS3W-M424-402-R
			5 m	XS3W-M424-405-R
			10 m	XS3W-M424-410-R
			20 m	XS3W-M424-420-R
Robot cable	Amplifier unit side: Straight Sensor head side: Straight		1 m	XS3W-M421-401-PR
			2 m	XS3W-M421-402-PR
			5 m	XS3W-M421-405-PR
			10 m	XS3W-M421-410-PR
			20 m	XS3W-M421-420-PR
	Amplifier unit side: L-shaped Sensor head side: L-shaped		1 m	XS3W-M422-401-PR
			2 m	XS3W-M422-402-PR
			5 m	XS3W-M422-405-PR
			10 m	XS3W-M422-410-PR
			20 m	XS3W-M422-420-PR
	Amplifier unit side: Straight Sensor head side: L-shaped		1 m	XS3W-M423-401-PR
			2 m	XS3W-M423-402-PR
			5 m	XS3W-M423-405-PR
			10 m	XS3W-M423-410-PR
			20 m	XS3W-M423-420-PR
	Amplifier unit side: L-shaped Sensor head side: Straight		1 m	XS3W-M424-401-PR
			2 m	XS3W-M424-402-PR
			5 m	XS3W-M424-405-PR
			10 m	XS3W-M424-410-PR
			20 m	XS3W-M424-420-PR

**Note:** You cannot use multiple extension cables connected together.











**<Key points in selecting your extension cable>**

- The pre-wired cable of the sensor head is a standard cable. In cases where cable bending is necessary, connect an extension robot cable, and bend the extension cable. We recommend you use a 0.2-m cable for your sensor head.
- Using the L-shaped cable connector for amplifier unit connection allows you to secure space around the area of connection.

**Mounting bracket**  
For ZP-LS025/-LS050/-LS100

Appearance	Illustration of installed bracket	Assembly tutorial video	Model
L-shaped Mounting Bracket 			ZP-XL1
Rear Mounting Bracket 			ZP-XL2
Flexible Mounting Bracket 			ZP-XL5
Post 50 mm 			E39-L262
Post 100 mm 			E39-L263

**For ZP-LS300/-LS600**

Appearance	Illustration of installed bracket	Assembly tutorial video	Model
L-shaped Mounting Bracket 			ZP-XL3
Rear Mounting Bracket 			ZP-XL4
Flexible Mounting Bracket 			ZP-XL6
Post 50 mm 			E39-L262
Post 100 mm 			E39-L263

## Recommended EtherNet/IP Communications Cables

For EtherNet/IP, required specification for the communications cables varies depending on the baud rate. For 100BASE-TX/10BASE-T, use a straight or cross STP (shielded twisted-pair) cable of category 5 or higher.

### Cable with Connectors

Item		Recommended manufacturer	Cable length (m)	Model
Wire gauge and number of pairs: AWG26, 4-pair cable Cable sheath material: PUR	Cable with Connectors on Both Ends (RJ45/RJ45) Standard RJ45 plugs *1 Cable color: Yellow *2 EtherNet/IP (10BASE/100BASE)	OMRON	0.3	XS6W-6PUR8SS30CM-YF
			0.5	XS6W-6PUR8SS50CM-YF
			1	XS6W-6PUR8SS100CM-YF
			2	XS6W-6PUR8SS200CM-YF
			3	XS6W-6PUR8SS300CM-YF
	Cable with Connectors on Both Ends (RJ45/RJ45) Rugged RJ45 plugs *1 Cable color: Light blue EtherNet/IP (10BASE/100BASE)		0.3	XS5W-T421-AMD-K
			0.5	XS5W-T421-BMD-K
			1	XS5W-T421-CMD-K
			2	XS5W-T421-DMD-K
			5	XS5W-T421-GMD-K
			10	XS5W-T421-JMD-K

\*1. Cables with standard RJ45 plugs are available in the following lengths: 0.2 m, 0.3 m, 0.5 m, 1 m, 1.5 m, 2 m, 3 m, 5 m, 7.5 m, 10 m, 15 m, 20 m.

Cables with rugged RJ45 plugs are available in the following lengths: 0.3 m, 0.5 m, 1 m, 2 m, 3 m, 5 m, 10 m, 15 m.

For details, refer to the *Industrial Ethernet Connectors Catalog* (Cat. No. G019).

\*2. Cable colors are available in yellow, green, and blue.

### Cables/Connectors

Item		Recommended manufacturer	Model
Products for EtherNet/IP (100BASE-TX/10BASE-T)	Wire gauge and number of pairs: AWG22, 2-pair cable	Cable	Kuramo Electric Co. JMACS Japan Co., Ltd.
		RJ45 Assembly Connector	OMRON
			

\*1. We recommend you to use the above Cable and RJ45 Assembly Connector together.

## Ratings and Performance

### Sensor Head

Item	Specification						
	ZP-LS025L(C)	ZP-LS025S(C)	ZP-LS050L(C)	ZP-LS050S(C)	ZP-LS100L(C)	ZP-LS100S(C)	
Reference distance	25 mm		50 mm		100 mm		
Measurement distance	20 to 30 mm		40 to 60 mm		65 to 135 mm		
Light source	Red semiconductor laser						
Wavelength	660 nm						
Laser class	ZP-LS□L, ZP-LS□S: Class 2 (JIS/IEC/EN/FDA) ZP-LS□LC, ZP-LS□SC: Class 1 (JIS/IEC/EN/FDA)						
Laser power	ZP-LS□L, ZP-LS□S: 1 mW max. ZP-LS□LC, ZP-LS□SC: 0.376 mW max.						
Spot diameter *1	Approx. 50 × 1,000 μm	Approx. 50 μm dia.	Approx. 70 × 1,600 μm	Approx. 70 μm dia.	Approx. 130 × 2,900 μm	Approx. 120 μm dia.	
Linearity *2	Near side	±0.05% F.S. (±5 μm)	±0.1% F.S. (±10 μm)	±0.03% F.S. (±6 μm)	±0.075% F.S. (±15 μm)	±0.025% F.S. (±17.5 μm)	±0.07% F.S. (±49 μm)
		when used at 20 to 25 mm		when used at 40 to 50 mm		when used at 65 to 100 mm	
	Total area	±0.08% F.S. (±8 μm)	±0.125% F.S. (±12.5 μm)	±0.04% F.S. (±8 μm)	±0.1% F.S. (±20 μm)	±0.065% F.S. (±45.5 μm)	±0.085% F.S. (±59.5 μm)
when used at 20 to 30 mm		when used at 40 to 60 mm		when used at 65 to 135 mm			
Resolution (Repeatability) *3	0.5 μm	0.6 μm	0.7 μm	0.8 μm	1.2 μm	1.3 μm	
Temperature characteristics *4	0.01% F.S./°C		0.01% F.S./°C		0.01% F.S./°C		
Indicators	2 indicators (identified by color) HIGH (orange)/PASS (green)/LOW (orange), Out of range (white), Error (red), SETTING mode (blue)						
Ambient illuminance	Illuminance of light-receiving surface, Incandescent lamp: 10,000 lx max.						
Ambient temperature range	Operating: -10 to 50°C, Storage: -15 to 70°C (with no icing or condensation)						
Ambient humidity range	Operating and storage: 35% to 85% RH each (with no condensation)						
Dielectric strength	1,000 VAC 50/60 Hz for 1 min.						
Insulation resistance	20 MΩ min. (at 500 VDC)						
Vibration resistance	10 to 500 Hz, double amplitude 1.5 mm, 120 min. each in X, Y and Z directions						
Shock resistance	300 m/s <sup>2</sup> , 3 times each in 6 directions along X, Y, and Z axes						
Degree of protection	IP67 (IEC60529)						
Connection method *5	Pre-wired Connector type (Standard cable length: 2 m/0.2 m)						
Material	Case and cover: Polybutylene terephthalate, Optical window: Glass, Threaded portion: Brass, Cable: PVC						
Weight (Main unit only)	Approx. 90 g (Cable length: 2 m), Approx. 45 g (Cable length: 0.2 m)						
Accessories	Instruction manual, compliance sheet, FDA certification label, fixing screws (M3 × 30 mm, 2 screws), laser warning label (ZP-LS□L and ZP-LS□S models only)						

\*1. This is the value (actual value) at the standard distance, which is defined as  $1/e^2$  (13.5%) of the central light intensity.

\*2. This shows the error of displacement output relative to the ideal line when OMRON's standard target (white diffuse object) is measured. Linearity and measured values may vary depending on the target object. F.S. refers to the entire measuring range (70 mm for ZP-LS100L).

\*3. This shows the width of the variation of measured values when OMRON's standard target (white diffuse object) is measured at a reference distance with a measurement cycle of 1 ms and an average rate of 128 times.

\*4. This is the value (typical value) measured at the reference distance, with the Sensor Head and OMRON's standard object (white diffuse object) fixed with an aluminum jig between them.

\*5. This product is powered by the Laser Displacement Sensor Amplifier Unit (ZP-L3□□□).

Item	Specification				
	ZP-LS300L(C)	ZP-LS300S(C)	ZP-LS600L(C)	ZP-LS600S(C)	
Reference distance	300 mm		600 mm		
Measurement distance	150 to 450 mm		200 to 1,000 mm		
Light source	Red semiconductor laser				
Wavelength	660 nm				
Laser class	ZP-LS□L, ZP-LS□S: Class 2 (JIS/IEC/EN/FDA) ZP-LS□LC, ZP-LS□SC: Class 1 (JIS/IEC/EN/FDA)				
Laser power	ZP-LS□L, ZP-LS□S: 1 mW max. ZP-LS□LC, ZP-LS□SC: 0.376 mW max.				
Spot diameter *1	Approx. 340 × 2,800 μm	Approx. 310 μm dia.	Approx. 670 × 5,800 μm	Approx. 600 μm dia.	
Linearity *2	Near side	±0.03% F.S. (±90 μm)	±0.04% F.S. (±120 μm)	±0.06% F.S. (±480 μm)	±0.075% F.S. (±600 μm)
		when used at 150 to 300 mm		when used at 200 to 600 mm	
	Total area	±0.1% F.S. (±300 μm)	±0.125% F.S. (±375 μm)	±0.15% F.S. (±1,200 μm)	±0.2% F.S. (±1,600 μm)
		when used at 150 to 450 mm		when used at 150 to 450 mm	
Resolution (Repeatability) *3	4 μm		14 μm		
Temperature characteristics *4	0.01% F.S./°C		0.02% F.S./°C		
Indicators	2 indicators (identified by color) HIGH (orange)/PASS (green)/LOW (orange), Out of range (white), Error (red), SETTING mode (blue)				
Ambient illuminance	Illuminance of light-receiving surface, Incandescent lamp: 5,000 lx max.				
Ambient temperature range	Operating: -10 to 50°C, Storage: -15 to 70°C (with no icing or condensation)				
Ambient humidity range	Operating and storage: 35% to 85% RH each (with no condensation)				
Dielectric strength	1,000 VAC 50/60 Hz for 1 min.				
Insulation resistance	20 MΩ min. (at 500 VDC)				
Vibration resistance	10 to 500 Hz, double amplitude 1.5 mm, 120 min. each in X, Y and Z directions				
Shock resistance	300 m/s <sup>2</sup> , 3 times each in 6 directions along X, Y, and Z axes				
Degree of protection	IP67 (IEC60529)				
Connection method *5	Pre-wired Connector type (Standard cable length: 2 m/0.2 m)				
Material	Case and cover: Polybutylene terephthalate, Optical window: Glass, Threaded portion: Brass, Cable: PVC				
Weight (Main unit only)	Approx. 110 g (Cable length: 2 m), Approx. 70 g (Cable length: 0.2 m)				
Accessories	Instruction manual, compliance sheet, FDA certification label, fixing screws (M3 × 35 mm. 2 screws), laser warning label (ZP-LS□L and ZP-LS□S models only)				

\*1. This is the value (actual value) at the standard distance, which is defined as  $1/e^2$  (13.5%) of the central light intensity.

\*2. This shows the error of displacement output relative to the ideal line when OMRON's standard target (white diffuse object) is measured.

Linearity and measured values may vary depending on the target object.

F.S. refers to the entire measuring range (70 mm for ZP-LS100L).

\*3. This shows the width of the variation of measured values when OMRON's standard target (white diffuse object) is measured at a reference distance with a measurement cycle of 1 ms and an average rate of 128 times.

\*4. This is the value (typical value) measured at the reference distance, with the Sensor Head and OMRON's standard object (white diffuse object) fixed with an aluminum jig between them.

\*5. This product is powered by the Laser Displacement Sensor Amplifier Unit (ZP-L3□□□).

## Amplifier Unit

### Master unit ZP-L30□□

Item	Specification				
	ZP-L3000	ZP-L3010	ZP-L3050	ZP-L3060	
Master/Slave unit	Master Unit				
I/O type	NPN		PNP		
Analog output *1	Current output	4 to 20 mA Maximum load resistance: 350 Ω	No analog output	4 to 20 mA Maximum load resistance: 350 Ω	No analog output
	Voltage output	±5 V, 1 to 5 V, 0 to 5 V Output impedance: 100 Ω		±5 V, 1 to 5 V, 0 to 5 V Output impedance: 100 Ω	
Control output *2	HIGH/PASS/LOW/ Error output Open collector output: 30 VDC, 50 mA max., Residual voltage: 2 V max. N.O./N.C. switchable				
External input	Zero reset, Laser OFF, Timing, Reset, BANK				
	When ON: 0 V short-circuit or 1.2 V max. When OFF: Open (Leakage current: 0.1 mA max.)		When ON: Power supply voltage short-circuit or within -1.2 V of power supply voltage When OFF: Open (Leakage current: 0.1 mA max.)		
Measurement cycle	125 μs/250 μs/500 μs/1 ms/2 ms/4 ms/20 ms/50 ms/100 ms switchable				
Maximum number of connected units	16 (15 slave units can be connected per master unit)				
Display	OLED display Judgment indicators: HIGH (orange/red), PASS (green/red), LOW (orange/red) Status indicators: LASER (green), ZERO (green), ENABLE (green)				
Power supply voltage *3	10 to 30 VDC, including 10% ripple (p-p)				
Power consumption *4	2,300 mW max.	2,000 mW max.	2,300 mW max.	2,000 mW max.	
Ambient temperature range	Operating: -10 to 50°C (standalone or multi-unit connection) Storage: -15 to 70°C (with no icing or condensation)				
Ambient humidity range	Operating and storage: 35% to 85% RH each (with no condensation)				
Dielectric strength	1,000 VAC 50/60 Hz for 1 min.				
Insulation resistance	20 MΩ min. (at 500 VDC)				
Vibration resistance	10 to 150 Hz, double amplitude 0.7 mm, 80 minutes each in X, Y, and Z directions				
Shock resistance	300 m/s <sup>2</sup> , 3 times each in 6 directions along X, Y, and Z axes				
Degree of protection *5	IP40 (IEC60529)				
Connection method	Cable pull-out type (Standard cable length: 2 m)				
Material	Main unit case, operating section cover: Polycarbonate Cable: PVC				
Weight (Main unit only)	Approx. 160 g	Approx. 150 g	Approx. 160 g	Approx. 150 g	
Accessories	Instruction manual, compliance sheet				

\*1. Select ±5 V, 1 to 5 V, 0 to 5 V, or 4 to 20 mA to use this.

\*2. When six or more Amplifier Units are added including the master unit, use a load current of 20 mA/ch or less.

\*3. Use a Class 2 power supply to supply power to this product. When six or more Amplifier Units are added including the master unit, use a power supply voltage of 20 to 30 V, including 10% ripple (p-p).

\*4. This includes the power consumption of the Sensor Head. It does not include the load current of each output.

\*5. For slave units, this indicates the degree of protection when connected.

## Slave unit ZP-L35□0

Item	Specification		
	ZP-L3510	ZP-L3560	ZP-L3590
Master/Slave unit	Slave Unit		
I/O type	NPN	PNP	No I/O
Analog output *1	Current output	No analog output	
	Voltage output		
Control output *2	HIGH/PASS/LOW/ Error output Open collector output: 30 VDC, 50 mA max., Residual voltage: 2 V max. N.O./N.C. switchable		No control output
External input	Zero reset, Laser OFF, Timing, Reset, BANK		No external input
	When ON: 0 V short-circuit or 1.2 V max. When OFF: Open (Leakage current: 0.1 mA max.)	When ON: Power supply voltage short-circuit or within -1.2 V of power supply voltage When OFF: Open (Leakage current: 0.1 mA max.)	
Measurement cycle	125 μs/250 μs/500 μs/1 ms/2 ms/4 ms/20 ms/50 ms/100 ms switchable		
Maximum number of connected units	16 (15 slave units can be connected per master unit)		
Display	OLED display Judgment indicators: HIGH (orange/red), PASS (green/red), LOW (orange/red) Status indicators: LASER (Green), ZERO (Green), ENABLE (Green)		
Power supply voltage *3	Supplied by master unit		
Power consumption *4	2,000 mW max.		
Ambient temperature range	Operating: -10 to 50°C (standalone or multi-unit connection) Storage: -15 to 70°C (with no icing or condensation)		
Ambient humidity range	Operating and storage: 35% to 85% RH each (with no condensation)		
Dielectric strength	1,000 VAC 50/60 Hz for 1 min.		
Insulation resistance	20 MΩ min. (at 500 VDC)		
Vibration resistance	10 to 150 Hz, double amplitude 0.7 mm, 80 minutes each in X, Y, and Z directions		
Shock resistance	300 m/s <sup>2</sup> , 3 times each in 6 directions along X, Y, and Z axes		
Degree of protection *5	IP40 (IEC60529)		
Connection method	Cable pull-out type (Standard cable length: 2 m)		None
Material	Main unit case, operating section cover: Polycarbonate Cable: PVC		Main unit case, operating section cover: Polycarbonate
Weight (Main unit only)	Approx. 140 g	Approx. 140 g	Approx. 70 g
Accessories	Instruction manual, compliance sheet		

\*1. Select ±5 V, 1 to 5 V, 0 to 5 V, or 4 to 20 mA to use this.

\*2. When six or more Amplifier Units are added including the master unit, use a load current of 20 mA/ch or less.

\*3. Use a Class 2 power supply to supply power to this product. When six or more Amplifier Units are added including the master unit, use a power supply voltage of 20 to 30 V, including 10% ripple (p-p).

\*4. This includes the power consumption of the Sensor Head. It does not include the load current of each output.

\*5. This indicates the degree of protection when connected to a master unit.

## Main functions

Function name	Description
<b>Measurement cycle</b>	Set as needed according to workpiece reflectance, tilt, etc. You can also use the auto-configuration feature to automatically set the optimal measurement cycle for the workpiece being measured.
<b>Average rate</b>	Set as needed according to measurement value stability.
<b>Calculation</b>	Enables calculation between multiple sensor heads and amplifier units. Provides addition and subtraction features, which you can use to measure level difference, thickness, etc. Calculation is performed by the master unit.
<b>Analog output</b>	Allows you to change analog output to voltage output and current output.
<b>Analog scaling</b>	Function for adjusting analog output against measurement results. Use, for example, when you want to present slight changes in displacement as large changes in analog output.
<b>Measurement scaling</b>	Function for applying correction to measurement results. Use when there is a difference between the expected result and measurement result, or when you want to apply a certain offset value.
<b>Detection select</b>	Allows you to select which surface to use for your measurement result, in cases where multiple measurement surfaces exist within the range of measurement. Use when measuring through glass, or detecting front/back surfaces of thin film.
<b>Differential calculation</b>	With this function, the measurement result is the difference between the current displacement amount and that of a given time earlier. Use when counting thin, board-like workpieces or when exclusively detecting sudden changes.
<b>Hold function</b>	With this function, the detection result is the feature value for the specified period. You can select which feature value to extract, e.g., the peak value (peak hold), the bottom value (bottom hold), the range of change (peak-to-peak hold), and so forth.
<b>Timer mode</b>	Allows you to delay upon changes in judgment output, or turn PASS output ON for a given period. Use when the judgment output changes so rapidly that upper-level devices cannot receive the signals.
<b>Synchronization</b>	Allows you to specify sensor head measurement timing. By staggering measurement timing, you can prevent mutual interference between sensors.
<b>BANK change</b>	Allows you to save/load sensor settings to the BANK. This function lets you change multiple settings (e.g., measurement cycles and threshold values) at once, which is useful in product changeovers, etc.

**Communication Unit**  
**General Specifications**

Item	Specification
	ZP-EIP
<b>Sensor that can be connected</b>	ZP-series Amplifier Unit
<b>Power supply voltage</b>	10 to 30 VDC, including 10% ripple (p-p) (supplied from Amplifier Unit)
<b>Power consumption</b>	1,500 mW max. (not including Amplifier Unit)
<b>Indicators</b>	MS (Green/Red), NS (Green/Red), L/A ETH1 (Green), U/IN PWR (Green), SS (Green/ Red)
<b>External input</b>	Mode 1: Control input for Communication Unit buffering (2 inputs) Mode 2: Cuing information input (2 inputs) <ul style="list-style-type: none"> <li>DC input method <ul style="list-style-type: none"> <li>Input voltage: 10 to 30 VDC</li> <li>Input current: 8 mA typical (24 VDC)</li> <li>ON voltage/current: 8.8 V min./2 mA min.</li> <li>OFF voltage/OFF current: 4 V max./0.5 mA max.</li> </ul> </li> </ul>
<b>Control output</b>	Communication Unit buffering status output (2 outputs) <ul style="list-style-type: none"> <li>Transistor output method <ul style="list-style-type: none"> <li>Output voltage: 10 to 30 VDC</li> <li>Maximum load current: 50 mA</li> <li>ON residual voltage: 2 V max.</li> <li>OFF leakage current: 0.1 mA max.</li> </ul> </li> </ul>
<b>Ambient temperature range</b>	Operating: -10 to 50°C, Storage: -15 to 70°C (with no icing or condensation)
<b>Ambient humidity range</b>	Operating and storage: 35% to 85% (with no condensation)
<b>Vibration resistance</b>	10 to 150 Hz, double amplitude 0.7 mm, 80 minutes each in X, Y, and Z directions
<b>Shock resistance</b>	300 m/s <sup>2</sup> , 3 times each in 6 directions along X, Y, and Z axes
<b>Dielectric strength</b>	1,000 VAC, 50/60 Hz for 1 minute
<b>Insulation resistance</b>	20 MΩ min. (at 500 VDC)
<b>Maximum number of connected sensors</b>	16 units max.
<b>Degree of protection *1</b>	IP20 (IEC60529)
<b>Material</b>	Polycarbonate
<b>Weight (Main unit only)</b>	Approx. 85 g
<b>Accessories</b>	Instruction manual, compliance sheet, End Plates (2)

\*1. This indicates the degree of protection when connected to an Amplifier Unit.

## EtherNet/IP Communications Specifications

Item		Specification
		ZP-EIP
<b>Communications protocols</b>		EtherNet/IP protocol <ul style="list-style-type: none"> <li>• Implicit messages (Class1)</li> <li>• Explicit messages (Class 3, UCMM)</li> </ul>
<b>Modulation</b>		Baseband
<b>Link speed</b>		10 Mbps or 100 Mbps
<b>Ethernet physical layer *1</b>		100BASE-TX or 10BASE-T (100BASE-TX is recommended.)
<b>Ethernet switch</b>		Layer-2 switch
<b>Transmission media</b>		Category 5 or higher twisted-pair cable (Recommended cable: double-shielded cable with aluminum tape and braiding)
<b>Transmission distance</b>		100 m or less (Distance between nodes and between hub and node)
<b>Topology</b>		Star, tree
<b>Number of connected Units</b>		<ul style="list-style-type: none"> <li>• Star No restrictions</li> <li>• Tree There is no restrictions in the number of cascade connections when an Ethernet switch is used.</li> </ul>
<b>EtherNet/IP tag data links</b>	<b>Number of connections *2</b>	1 (Point to Point)
	<b>Packet Interval (RPI)</b>	1 to 10,000 ms
	<b>Allowed communications bandwidth per Unit</b>	4,000 pps
<b>Explicit message</b>	<b>Class 3 (number of connections) *2</b>	5
	<b>UCMM (unconnected) *2</b>	Supported
<b>EtherNet/IP I/O connection size</b>		Input: 276 bytes max. (including input data, status, and unused areas) Output: 24 bytes max. (including output data and unused areas)
<b>Support functions</b>	<b>Supported services</b>	Tag data link, CIP message communications, automatic clock adjustment (NTP/SNTP client), BOOTP client, DHCP client
	<b>IP address conflict detection</b>	Provided

\*1. If tag data links are used, use 100BASE-TX.

\*2. The maximum number of connections is 10 when tag data links (Class 1), Class 3, and UCMM are used simultaneously.

# ZP-L

## Spot Diameter

ZP-LS025S

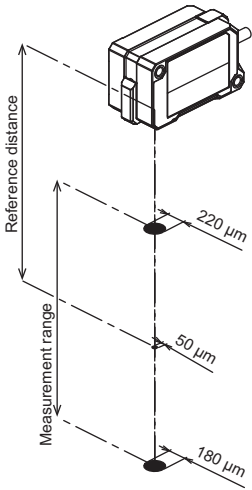

ZP-LS025L

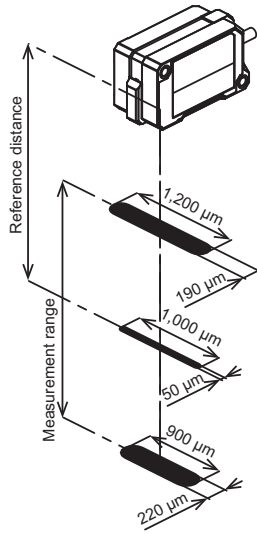

ZP-LS050S

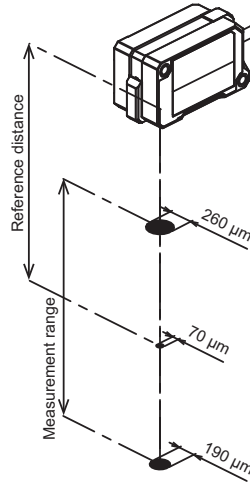

ZP-LS050L

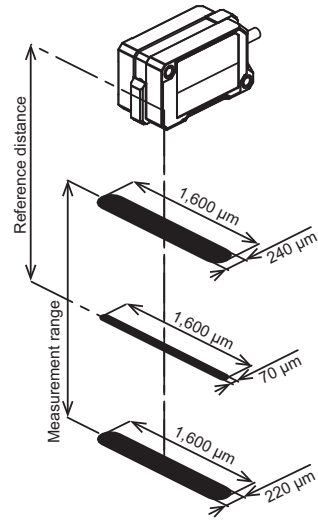

ZP-LS100S

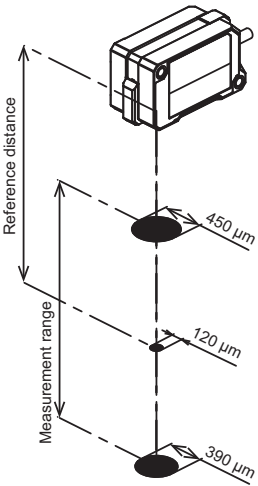

ZP-LS100L

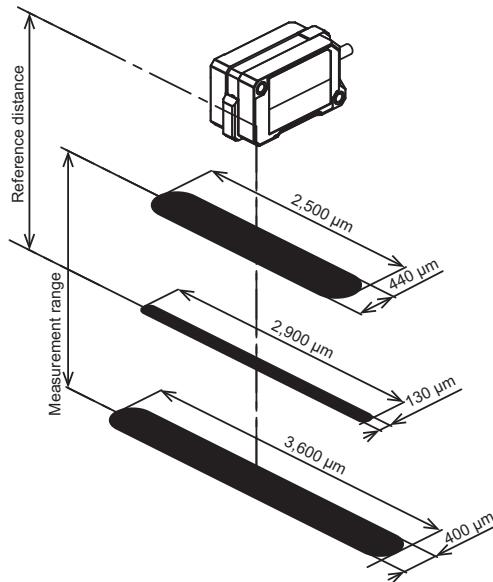

ZP-LS300S

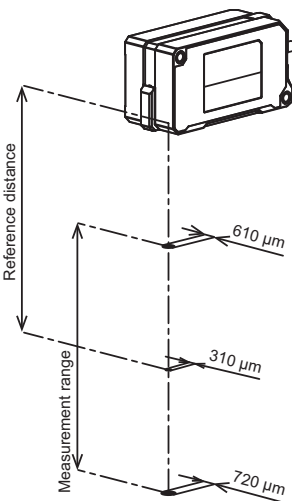

ZP-LS300L

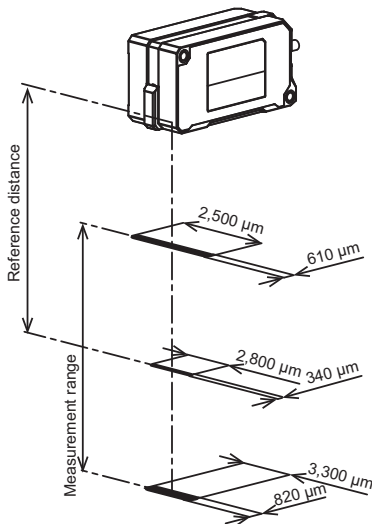

ZP-LS600S

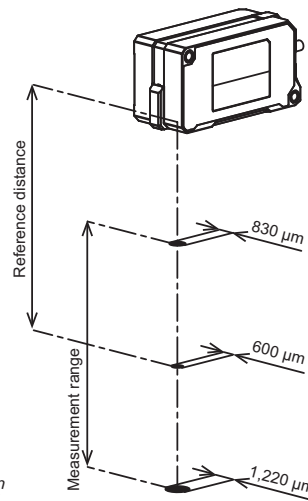

ZP-LS600L

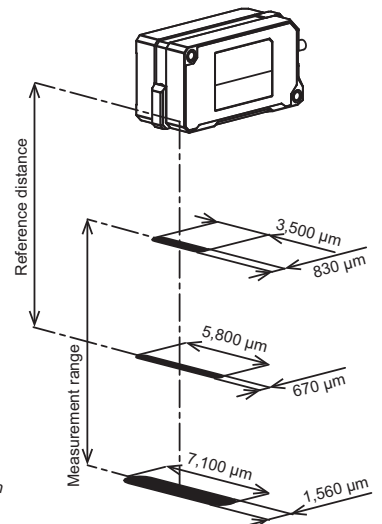

# I/O Circuit Diagrams

## ZP-L3000/ZP-L3010/ZP-L3510 (NPN Type)

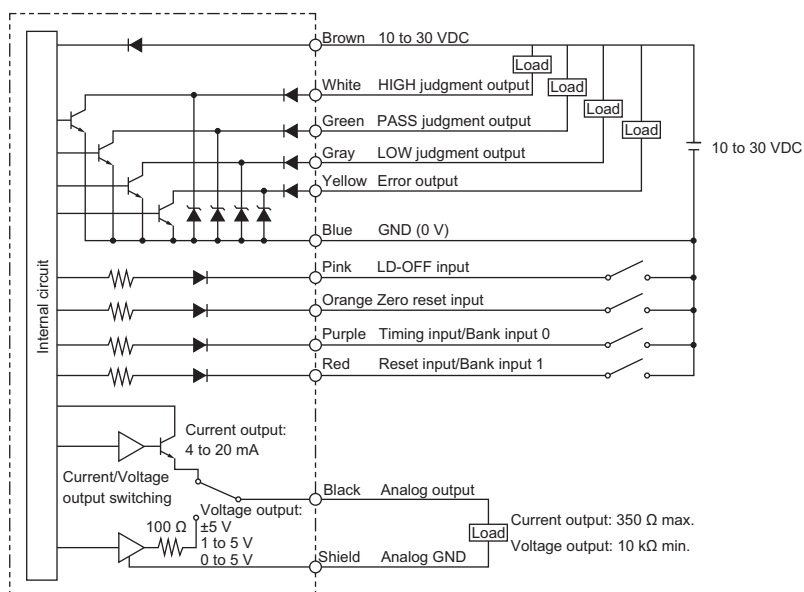

Item	ZP-L3000	ZP-L3010/ZP-L3510
<b>Power consumption *1</b>	2,300 mW max.	2,000 mW max.
<b>Control output</b>	Open collector output: 30 VDC, 50 mA max. (20 mA per channel when 5 or more additional slave units are installed) Residual voltage: 2 V max.	
<b>External input</b>	When ON: 0 V short-circuit or 1.2 V max. When OFF: Open (Leakage current: 0.1 mA max.)	
<b>Analog output</b>	Current output: 4 to 20 mA (Maximum load resistance: 350 Ω) Voltage output: 5 V, 1 to 5 V, 0 to 5 V (Output impedance: 100 Ω)	No analog output

## ZP-L3050/ZP-L3060/ZP-L3560 (PNP Type)

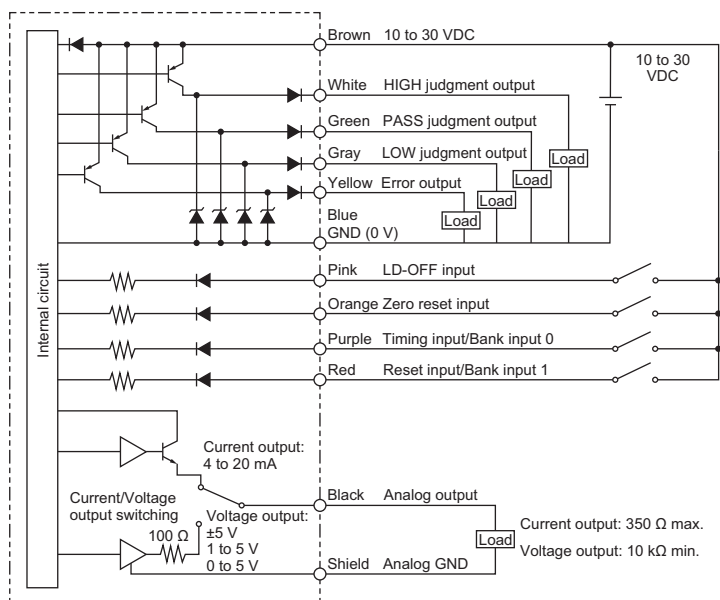

Item	ZP-L3050	ZP-L3060/ZP-L3560
<b>Power consumption *1</b>	2,300 mW max.	2,000 mW max.
<b>Control output</b>	Open collector output: 30 VDC, 50 mA max. (20 mA per channel when 5 or more additional slave units are installed) Residual voltage: 2 V max.	
<b>External input</b>	When ON: Power supply voltage short-circuit or within -1.2 V of power supply voltage When OFF: Open (Leakage current: 0.1 mA max.)	
<b>Analog output</b>	Current output: 4 to 20 mA (Maximum load resistance: 350 Ω) Voltage output: 5 V, 1 to 5 V, 0 to 5 V (Output impedance: 100 Ω)	No analog output

\*1. This includes the power consumption of the Sensor Head. It does not include the load current of each output. The power consumption of the ZP-L3590 is 2,000 mW max.

# ZP-L

## Wiring

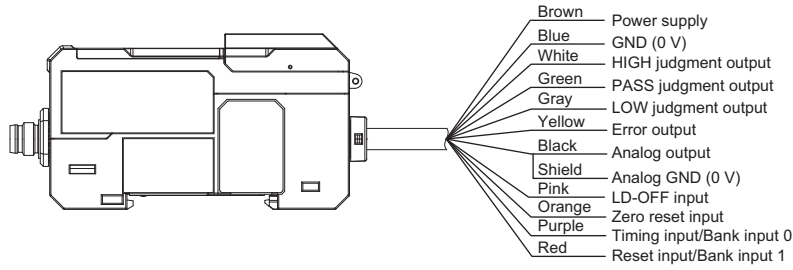

ZP-L3010/ZP-L3060 does not have black (analog output/GND).  
 ZP-L3510/ZP-L3560 does not have black (analog output/GND), brown (power supply), and blue (GND).  
 ZP-L3590 does not have power supply or input/output lines.

## Dimensions

(Unit: mm)

### Sensor Head

- ZP-LS025□
- ZP-LS050□
- ZP-LS100□

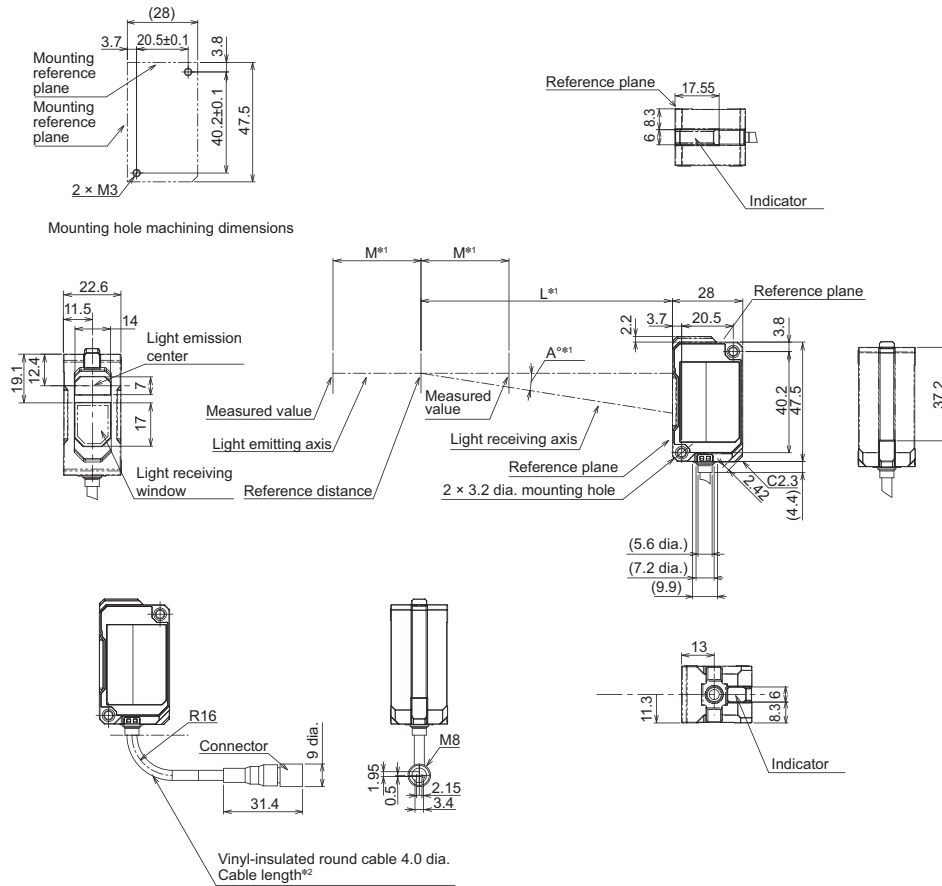

*1.	Model	L	M	A
	ZP-LS025□	25	5	24.2
	ZP-LS050□	50	10	16.4
	ZP-LS100□	100	35	9

*2.	Length specification	Standard length (mm)
	0.2 M	(260)
	2 M	(2000)

ZP-LS300□  
ZP-LS600□

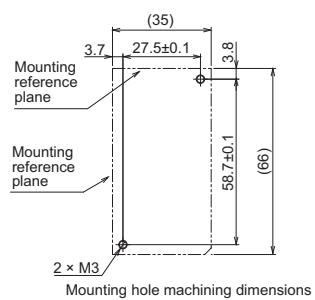

Mounting hole machining dimensions

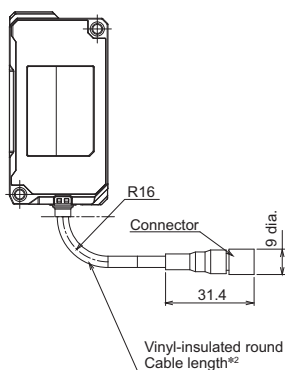
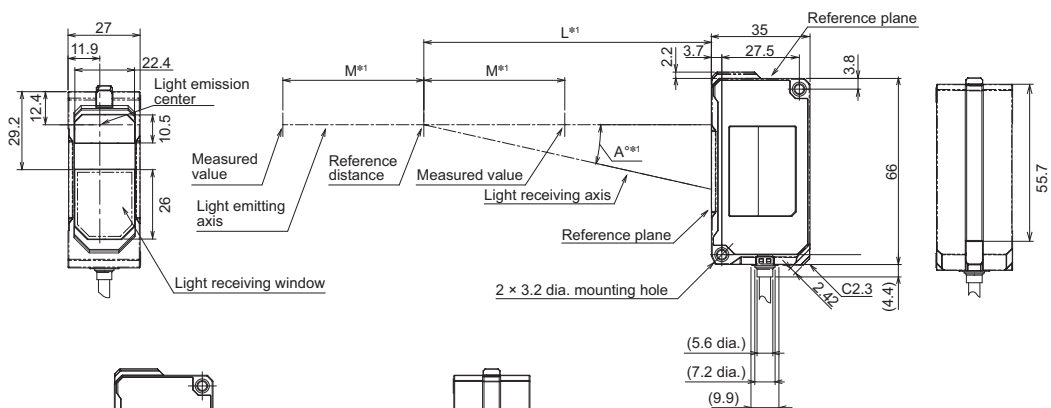
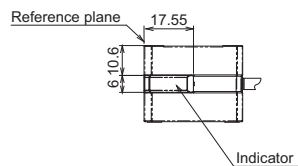

*1.	Model	L	M	A
	ZP-LS300□	300	150	5.91
	ZP-LS600□	600	400	2.95

*2.	Length specification	Standard length (mm)
	0.2 M	(260)
	2 M	(2000)

## Amplifier unit Master unit ZP-L30□□

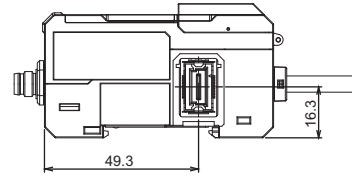
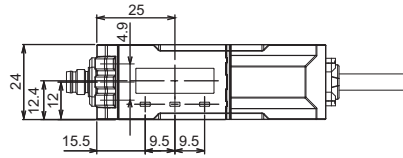

Amplifier Unit connector position

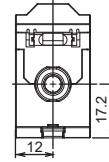
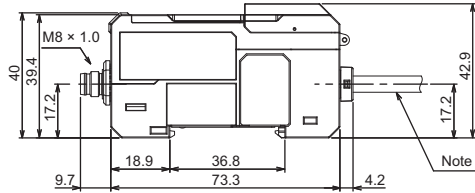

XS3W connector cable socket (straight)

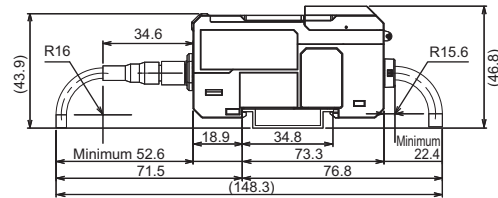

When ZP-LS□ and extension cable (XS3W-M421/M423-□-R) are connected

XS3W connector cable socket (L shape)

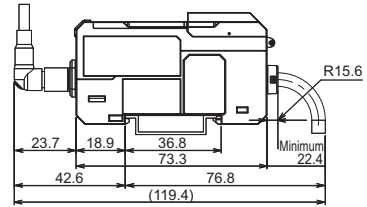

When extension cable (XS3W-M422/M424-□-□) is connected

XS3W connector cable socket (straight)

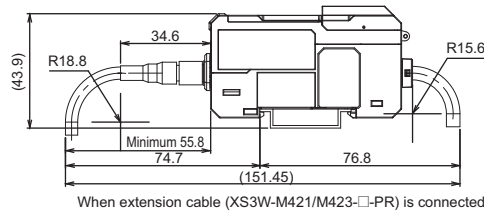

When extension cable (XS3W-M421/M423-□-PR) is connected

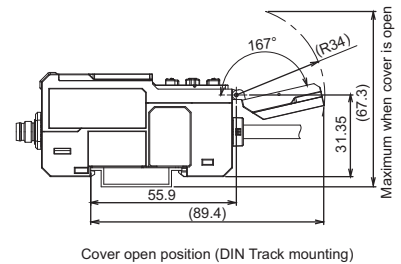

Cover open position (DIN Track mounting)

**Note:** The cable specifications are as follows:

Model	Cable outside diameter	Number of conductors	Conductor cross-section (mm <sup>2</sup> )		AWG size		Cable length
			Brown/Blue/Black	Others	Brown/Blue/Black	Others	
ZP-L3000	5.2 mm dia.	11	0.22 *1	0.09	24	28	2 m
ZP-L3010		10					
ZP-L3050		11					
ZP-L3060		10					

\*1. Black wire not provided for ZP-L3010 and ZP-L3060

**Slaver unit**  
**ZP-L3510**  
**ZP-L3560**

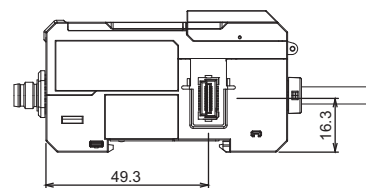
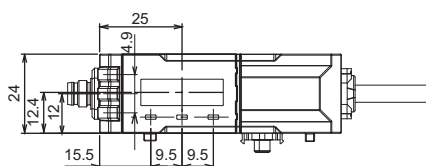

Amplifier Unit connector position

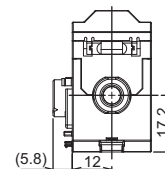
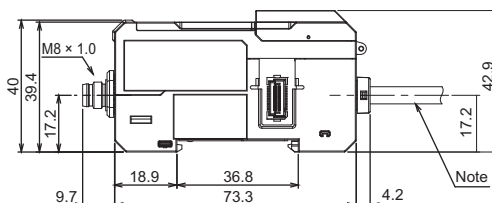

**Note:** The cable specifications are as follows:

Model	Cable outside diameter	Number of conductors	Conductor cross-section (mm <sup>2</sup> )	AWG size	Cable length
ZP-L3510	5.2 mm dia.	8	0.09	28	2 m
ZP-L3560					

**ZP-L3590**

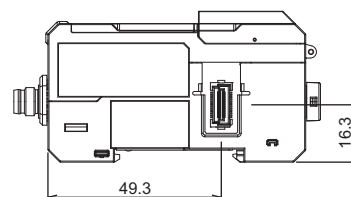
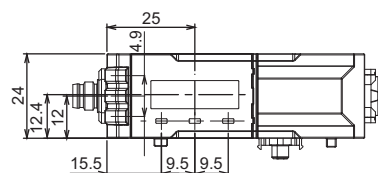

Unit coupling connector position

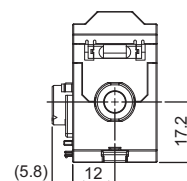
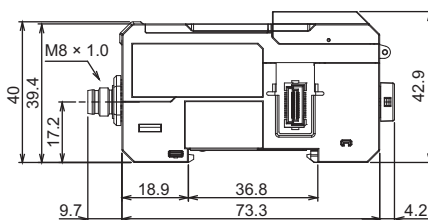

Accessories (sold separately)

Communication Unit

ZP-EIP

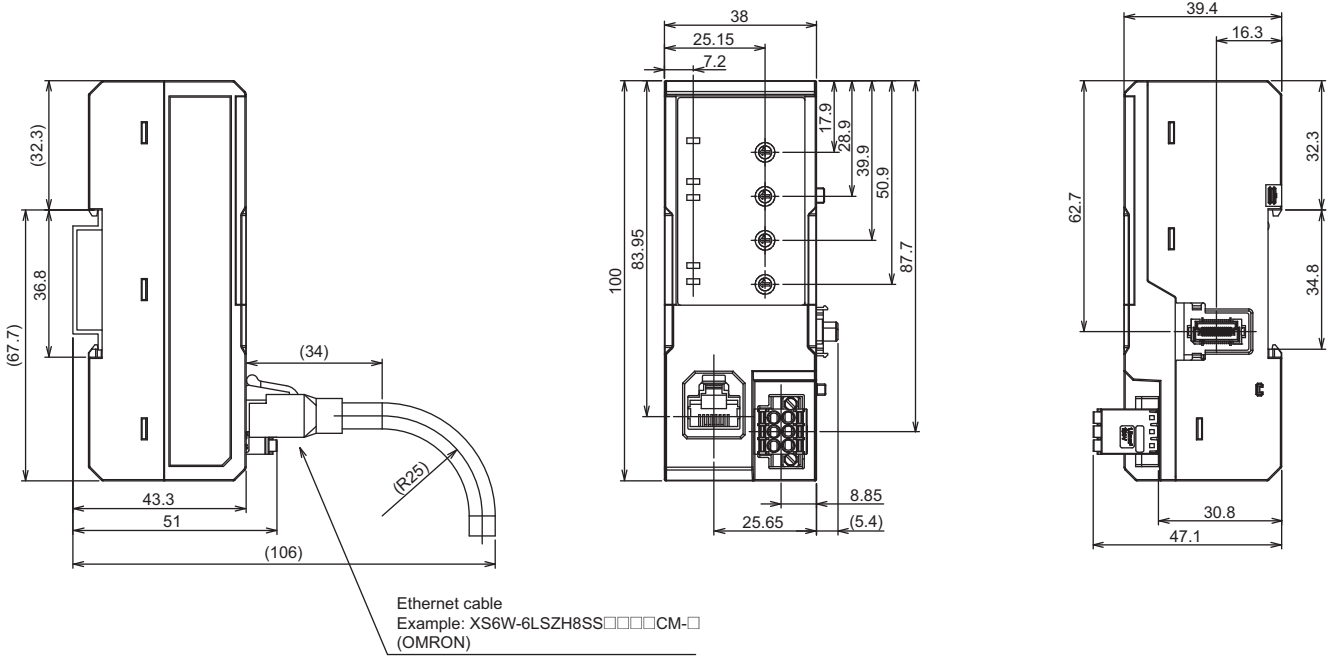

Mounting bracket

ZP-XL1



Mounting bracket

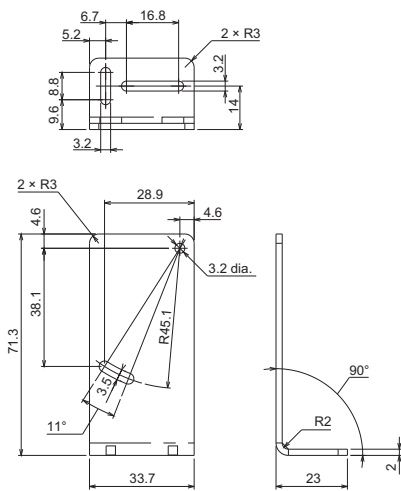

Material: Stainless steel (SUS304)  
Weight: Approx. 43 g

Fixing bracket

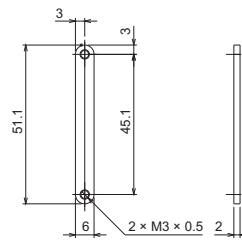

Material: Stainless steel (SUS304)  
Weight: Approx. 4 g

ZP-XL2



Mounting bracket

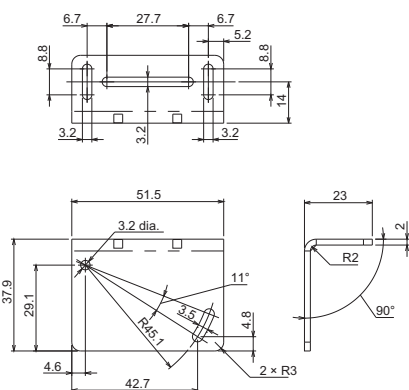

Material: Stainless steel (SUS304)  
Weight: Approx. 41 g

Fixing bracket

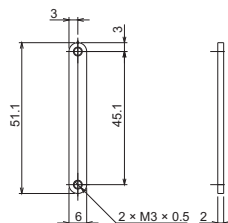

Material: Stainless steel (SUS304)  
Weight: Approx. 4 g

ZP-XL3



Mounting bracket

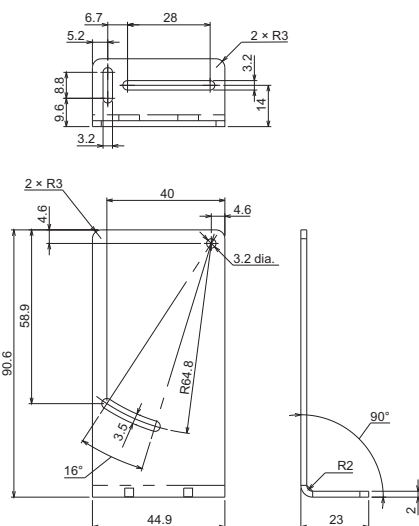

Material: Stainless steel (SUS304)  
Weight: Approx. 71 g

Fixing bracket

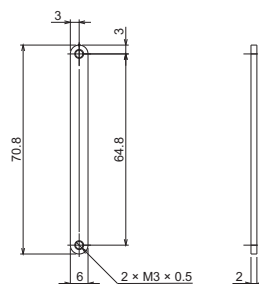

Material: Stainless steel (SUS304)  
Weight: Approx. 6 g

ZP-XL4



Mounting bracket

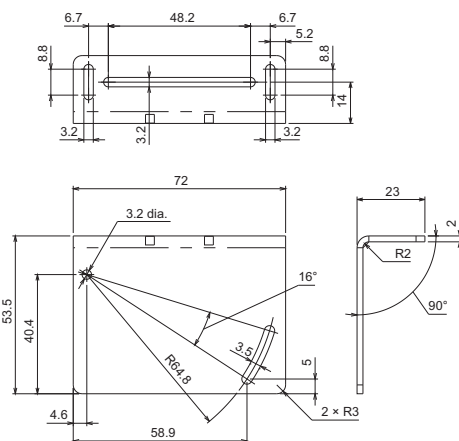

Material: Stainless steel (SUS304)  
Weight: Approx. 73 g

Fixing bracket

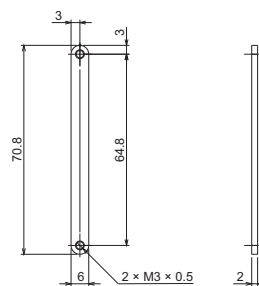

Material: Stainless steel (SUS304)  
Weight: Approx. 6 g

# ZP-L

## ZP-XL5



**Clamp**

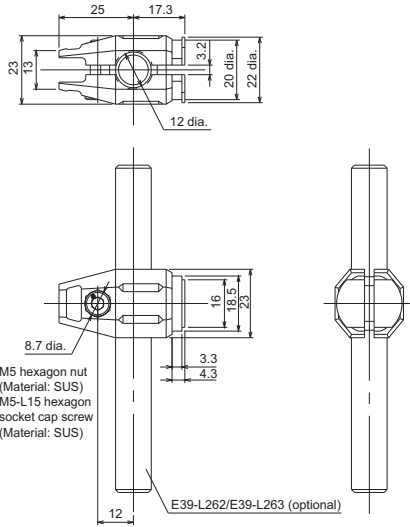

Material: Zinc die casting (ZDC2)  
Weight: Approx. 56 g (including clamp fixing screw)

**Bracket**

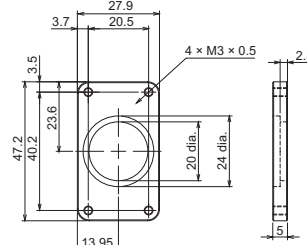

Material: Aluminum (A5052)  
Weight: Approx. 12 g

## ZP-XL6



**Clamp**

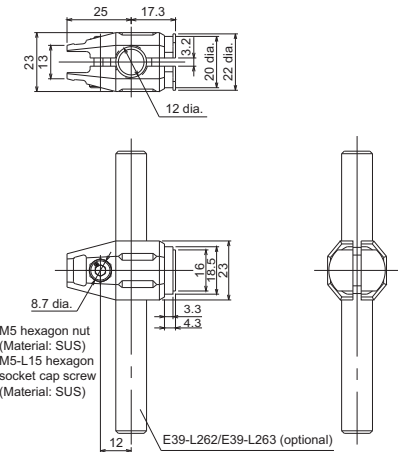

Material: Zinc die casting (ZDC2)  
Weight: Approx. 56 g (including clamp fixing screw)

**Bracket**

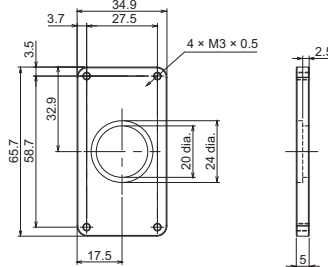

Material: Aluminum (A5052)  
Weight: Approx. 25 g

## Related Manuals

Man. No.	Model	Manual
Z495	ZP-LS□□/ZP-L3□□□	ZP Series Laser Displacement Sensor User's Manual
Z496	ZP-EIP	ZP-series EtherNet/IP™ Communications Unit

- EtherNet/IP™ is a trademark of ODVA.
- QR code is the registered trademark of DENSO WAVE.
- Microsoft product screen shot(s) reprinted with permission from Microsoft Corporation.
- Other company names and product names in this document are the trademarks or registered trademarks of their respective companies.

# Terms and Conditions Agreement

## **Read and understand this catalog.**

Please read and understand this catalog before purchasing the products. Please consult your OMRON representative if you have any questions or comments.

## **Warranties.**

(a) Exclusive Warranty. Omron's exclusive warranty is that the Products will be free from defects in materials and workmanship for a period of twelve months from the date of sale by Omron (or such other period expressed in writing by Omron). Omron disclaims all other warranties, express or implied.

(b) Limitations. OMRON MAKES NO WARRANTY OR REPRESENTATION, EXPRESS OR IMPLIED, ABOUT NON-INFRINGEMENT, MERCHANTABILITY OR FITNESS FOR A PARTICULAR PURPOSE OF THE PRODUCTS. BUYER ACKNOWLEDGES THAT IT ALONE HAS DETERMINED THAT THE PRODUCTS WILL SUITABLY MEET THE REQUIREMENTS OF THEIR INTENDED USE.

Omron further disclaims all warranties and responsibility of any type for claims or expenses based on infringement by the Products or otherwise of any intellectual property right. (c) Buyer Remedy. Omron's sole obligation hereunder shall be, at Omron's election, to (i) replace (in the form originally shipped with Buyer responsible for labor charges for removal or replacement thereof) the non-complying Product, (ii) repair the non-complying Product, or (iii) repay or credit Buyer an amount equal to the purchase price of the non-complying Product; provided that in no event shall Omron be responsible for warranty, repair, indemnity or any other claims or expenses regarding the Products unless Omron's analysis confirms that the Products were properly handled, stored, installed and maintained and not subject to contamination, abuse, misuse or inappropriate modification. Return of any Products by Buyer must be approved in writing by Omron before shipment. Omron Companies shall not be liable for the suitability or unsuitability or the results from the use of Products in combination with any electrical or electronic components, circuits, system assemblies or any other materials or substances or environments. Any advice, recommendations or information given orally or in writing, are not to be construed as an amendment or addition to the above warranty.

See <http://www.omron.com/global/> or contact your Omron representative for published information.

## **Limitation on Liability: Etc.**

OMRON COMPANIES SHALL NOT BE LIABLE FOR SPECIAL, INDIRECT, INCIDENTAL, OR CONSEQUENTIAL DAMAGES, LOSS OF PROFITS OR PRODUCTION OR COMMERCIAL LOSS IN ANY WAY CONNECTED WITH THE PRODUCTS, WHETHER SUCH CLAIM IS BASED IN CONTRACT, WARRANTY, NEGLIGENCE OR STRICT LIABILITY.

Further, in no event shall liability of Omron Companies exceed the individual price of the Product on which liability is asserted.

## **Suitability of Use.**

Omron Companies shall not be responsible for conformity with any standards, codes or regulations which apply to the combination of the Product in the Buyer's application or use of the Product. At Buyer's request, Omron will provide applicable third party certification documents identifying ratings and limitations of use which apply to the Product. This information by itself is not sufficient for a complete determination of the suitability of the Product in combination with the end product, machine, system, or other application or use. Buyer shall be solely responsible for determining appropriateness of the particular Product with respect to Buyer's application, product or system. Buyer shall take application responsibility in all cases.

NEVER USE THE PRODUCT FOR AN APPLICATION INVOLVING SERIOUS RISK TO LIFE OR PROPERTY OR IN LARGE QUANTITIES WITHOUT ENSURING THAT THE SYSTEM AS A WHOLE HAS BEEN DESIGNED TO ADDRESS THE RISKS, AND THAT THE OMRON PRODUCT(S) IS PROPERLY RATED AND INSTALLED FOR THE INTENDED USE WITHIN THE OVERALL EQUIPMENT OR SYSTEM.

## **Programmable Products.**

Omron Companies shall not be responsible for the user's programming of a programmable Product, or any consequence thereof.

## **Performance Data.**

Data presented in Omron Company websites, catalogs and other materials is provided as a guide for the user in determining suitability and does not constitute a warranty. It may represent the result of Omron's test conditions, and the user must correlate it to actual application requirements. Actual performance is subject to the Omron's Warranty and Limitations of Liability.

## **Change in Specifications.**

Product specifications and accessories may be changed at any time based on improvements and other reasons. It is our practice to change part numbers when published ratings or features are changed, or when significant construction changes are made. However, some specifications of the Product may be changed without any notice. When in doubt, special part numbers may be assigned to fix or establish key specifications for your application. Please consult with your Omron's representative at any time to confirm actual specifications of purchased Product.

## **Errors and Omissions.**

Information presented by Omron Companies has been checked and is believed to be accurate; however, no responsibility is assumed for clerical, typographical or proofreading errors or omissions.

## Sensors for distance measurement

We offer an array of products for a wide range of detection distances and accuracies.

For detection level difference of around  
**1 mm**

**Photoelectric sensor**  
**E3AS-HL series**



For resolution of  
**0.5  $\mu\text{m}$**

**Displacement sensor**  
**ZP-L series**



For resolution of  
**0.002  $\mu\text{m}$**

**Displacement sensor**  
**ZW series**



**Note: Do not use this document to operate the Unit.**

**OMRON Corporation Industrial Automation Company**

**Kyoto, JAPAN**

**Contact : [www.ia.omron.com](http://www.ia.omron.com)**

### **Regional Headquarters**

#### **OMRON EUROPE B.V.**

Wegalaan 67-69, 2132 JD Hoofddorp  
The Netherlands  
Tel: (31) 2356-81-300 Fax: (31) 2356-81-388

#### **OMRON ELECTRONICS LLC**

2895 Greenspoint Parkway, Suite 200  
Hoffman Estates, IL 60169 U.S.A.  
Tel: (1) 847-843-7900 Fax: (1) 847-843-7787

#### **OMRON ASIA PACIFIC PTE. LTD.**

438B Alexandra Road, #08-01/02 Alexandra  
Technopark, Singapore 119968  
Tel: (65) 6835-3011 Fax: (65) 6835-3011

#### **OMRON (CHINA) CO., LTD.**

Room 2211, Bank of China Tower,  
200 Yin Cheng Zhong Road,  
PuDong New Area, Shanghai, 200120, China  
Tel: (86) 21-6023-0333 Fax: (86) 21-5037-2388

**Authorized Distributor:**

©OMRON Corporation 2024-2025 All Rights Reserved.  
In the interest of product improvement,  
specifications are subject to change without notice.

**CSM\_2\_2**

**Cat. No. Q362-E1-03** 0225 (1124)