



Film Capacitors - Power Electronic Capacitors

PEC MKP DC

Series/Type: MKP DC (Metal Top)
Ordering code: B25680*
Date: April 2026
Version: 3

Construction and general data

Characteristics	
Standard capacitance tolerance	K: $\pm 10\%$
Dielectric dissipation factor ($\tan \delta_o$)	$2 \cdot 10^{-4}$
Service life expectancy (refer to section 3)	100000 h at $T_{hs} +75^\circ\text{C}$ and V_{RDC} ($\varnothing \leq 116$ mm and $V_{RDC} \leq 2000$ V) 100000 h at $T_{hs} +70^\circ\text{C}$ and V_{RDC} ($\varnothing = 136$ mm or $V_{RDC} > 2000$ V) up to 200000 h (Considering de-ratings in voltage and/or temperature upon request)
Humidity against performance	1000 h at $+85^\circ\text{C}/85\%\text{RH}$ and V_{RDC}
Smoke and Fire compliant with EN45545	HL2 (R22), HL3 (R23)
Expected Fit rate $\alpha_{FQ} (co)$	50 fit at V_{RDC} and $+70^\circ\text{C}$ (refer to section 4)
Minimum temperature $T_{min.}$	-40°C
Maximum temperature $T_{max.}$	$+85^\circ\text{C}$ for diameter 85 mm $+75^\circ\text{C}$ for diameter 116 and 136 mm
Storage temperature T_{stg}	$-40 \dots +85^\circ\text{C}$
Maximum hotspot temperature T_{hs} (refer to section 1)	$+85^\circ\text{C}$ for diameter 85 mm $+75^\circ\text{C}$ for diameter 116 and 136 mm
Climatic category	40/85/56 for 85 mm diameter 40/75/56 for 116 and 136 mm diameter
Maximum altitude	2000 m above sea level (derating curves for altitudes higher than 2000 m available upon request)
Frequency range	100 Hz \sim 10 kHz for $C_R \leq 1500 \mu\text{F}$ 100 Hz \sim 5 kHz for $1500 \mu\text{F} < C_R \leq 3000 \mu\text{F}$ 100 Hz \sim 3 kHz for $3000 \mu\text{F} < C_R \leq 4000 \mu\text{F}$ High frequency designs available upon request Permit I_{max} of specified frequency need be evaluated by customer
Safety device	No internal protection
Test data	
Voltage between terminals V_{TT}	$1.5 V_{RDC}$, 10 s
Voltage between terminals and case V_{TC}	$V_{RDC} \leq 2000$ V DC: 4000 V AC / 10 s $V_{RDC} = 2800$ V DC: 5000 V AC / 10 s $V_{RDC} = 3000$ V DC: 5250 V AC / 10 s
Design data	
Resin filling	Non PCB, hard polyurethane (dry type)
Mounting and grounding	M12 threaded bolt on bottom of the aluminum case
Max. torque (case) M12 stud	10 Nm
Max. torque terminal	Female M6: 5 Nm
Cooling	Naturally air-cooled (or forced air cooling)
Degree of protection	IP00 (Indoor mounting)
Reference standards	
IEC 61071 - 2017, GB/T 17702-2021	
RoHS and CE compliance	

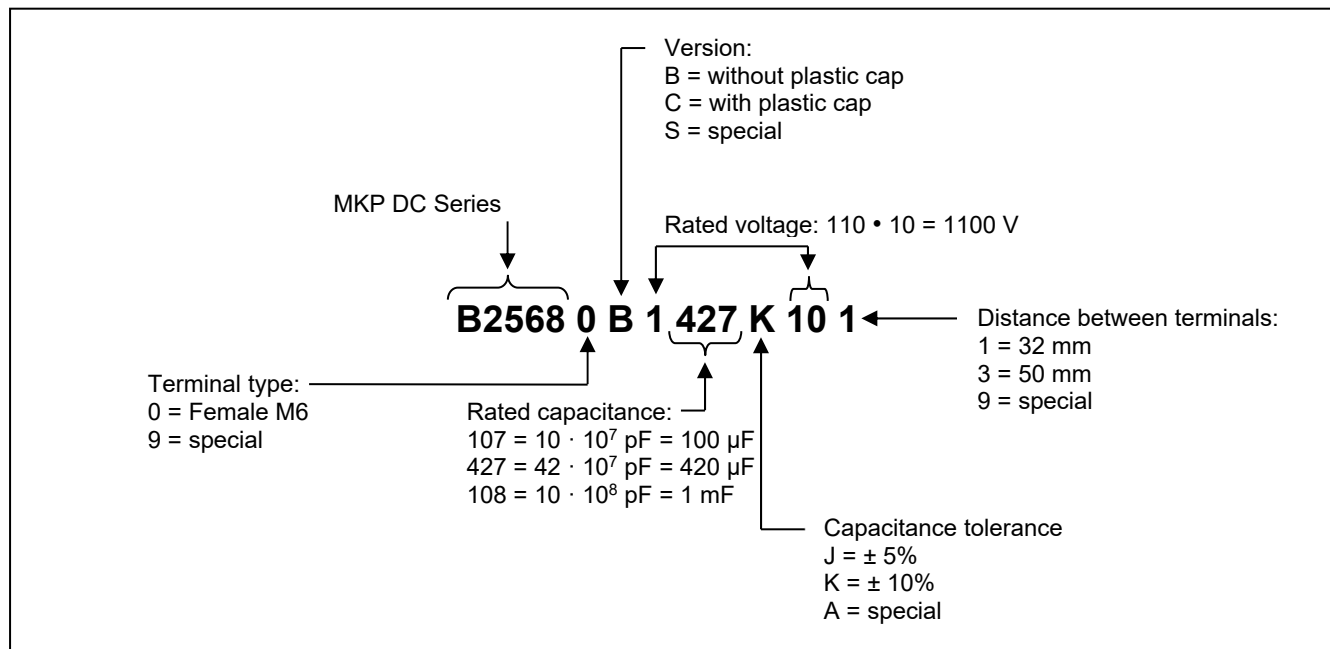
Structure of ordering code

Label information

TDK

B25680B1427K101

420 μF $\pm 10\%$

V_{RDC} = 1100V

V_{TC} = 4kV

-40...+85°C IEC 61071

SH-No PCB Dry Type

Max. torque of terminals: 5Nm

Discharge before handling

Made by TDK 20 Z 2022

905896733001

The label explanation is following:

20 Z 2022: Production in TDK Electronics Zhuhai factory **2022** year, calendar week **20**;

Bar code consists of lot number and serial number:

Lot number: 9 digits (ex.: **905896733**)

Serial number: 3 digits (ex.: **001**)

Standard types

Distance between terminals (mm) OC ending		32 ± 0.5 - ^{**1}	50 ± 0.5 - ^{**3}
Diameter (Ø)	Terminal type		
85 mm	Female M6	standard	
116 mm	Female M6		standard
136 mm	Female M6		standard

Other terminal configurations available upon request.

Clearance and Creepage distances

Diameter (Ø) mm	Plastic cap (L) mm	Terminal to Terminal		Terminal to Case	
		Typical clearance mm	Typical creepage mm	Typical clearance mm	Typical creepage mm
85	without	17.0	23.0	17.0	21.5
85	35	19.5	19.5	60.0	60.0
116	without	35.0	35.0	21.5	30.0
116	35	35.0	35.0	64.5	64.5
136	without	35.0	35.0	21.5	30.0
136	35	35.0	35.0	74.5	74.5

Other terminal configurations available upon request.

Packing information

Diameter (Ø)	Packing design
85 mm	4 capacitors per box or 12 capacitors per box
116/136 mm	4 capacitors per box

Each carton box may contain carton plates to fill the empty space, the number of carton plates will be defined by actual demand.

Dimensional Drawings

Figure 1: - B25680B - Ø 85 mm

- Female terminals (M6)
- Between terminals 32 ± 0.5 mm

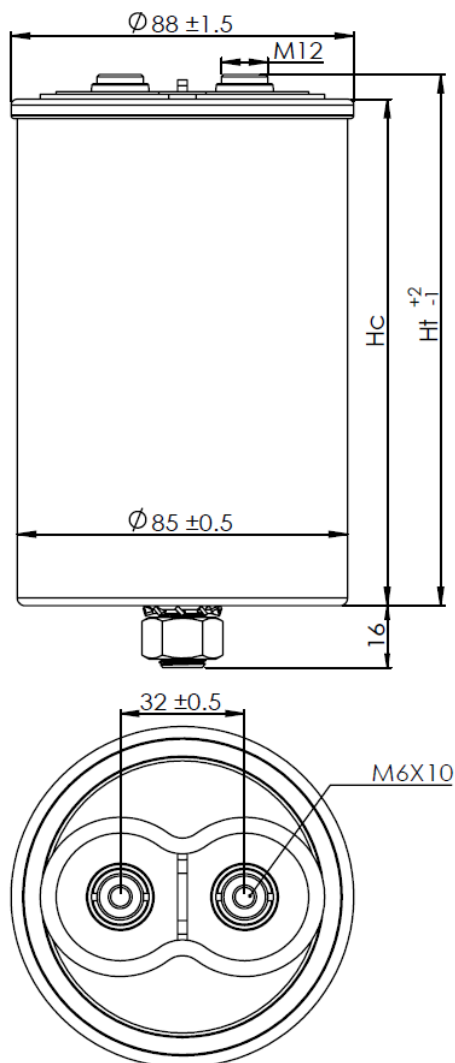
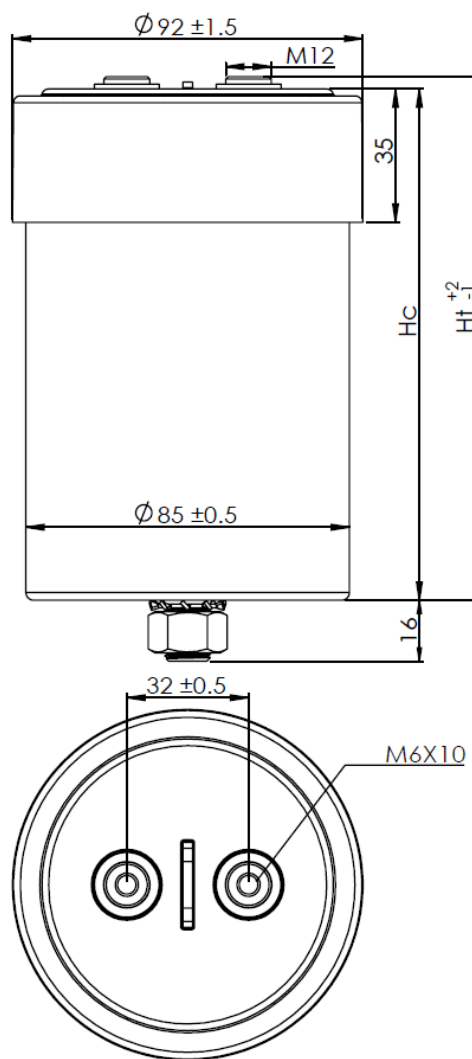

Figure 2: - B25680C - Ø 85 mm

- Female terminals (M6)
- Between terminals 32 ± 0.5 mm



M12 stud on bottom of the aluminum case, nut (DIN 934) and toothed lock washer (DIN 6797) for fixing are standard for all types.

Figure 4: - B25680C - \varnothing 116 mm
 - Female terminals (M6)
 - Between terminals 50 ± 0.5 mm

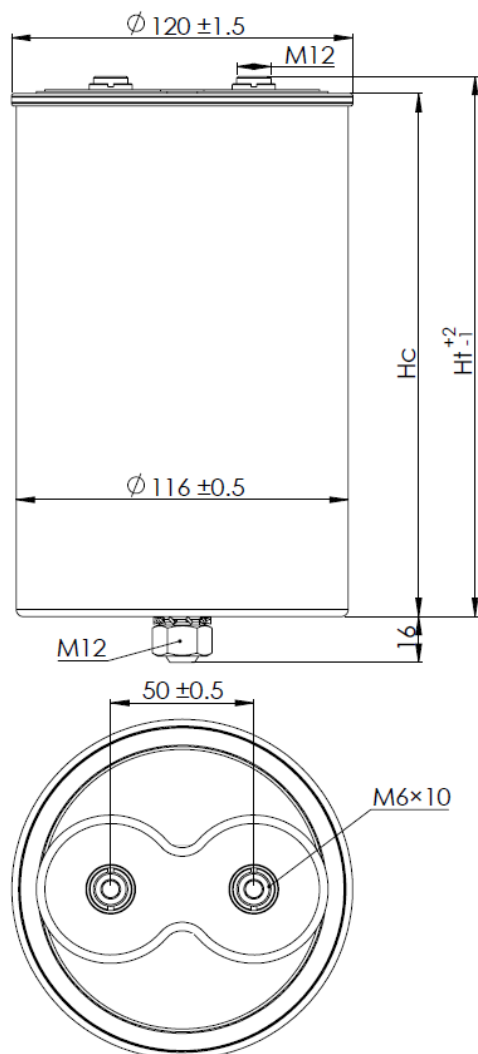
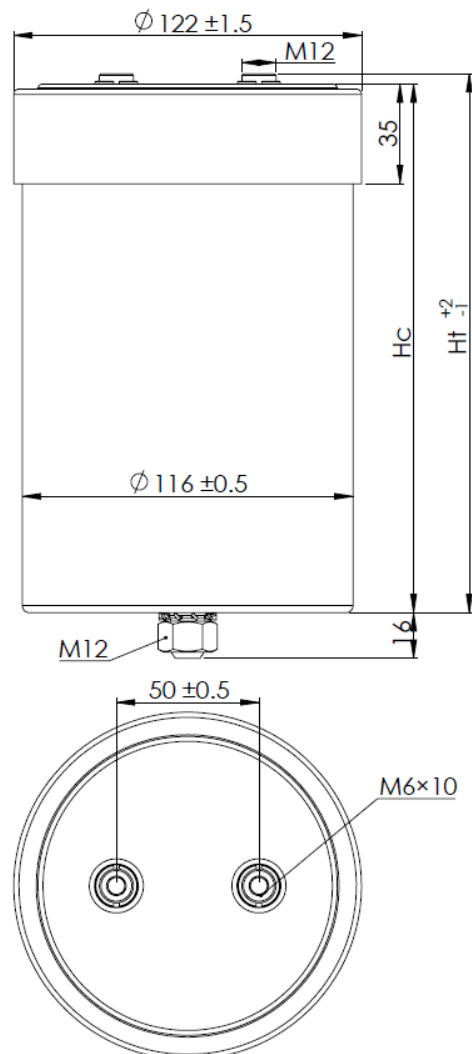

Figure 3: - B25680B - \varnothing 116 mm
 - Female terminals (M6)
 - Between terminals 50 ± 0.5 mm



M12 stud on bottom of the aluminum case, nut (DIN 934) and toothed lock washer (DIN 6797) for fixing are standard for all types.

Figure 5: - B25680B - Ø 136 mm
 - Female terminals (M6)
 - Between terminals 50 ±0.5mm

Figure 6: - B25680C - Ø 136 mm
 - Female terminals (M6)
 - Between terminals 50 ±0.5 mm

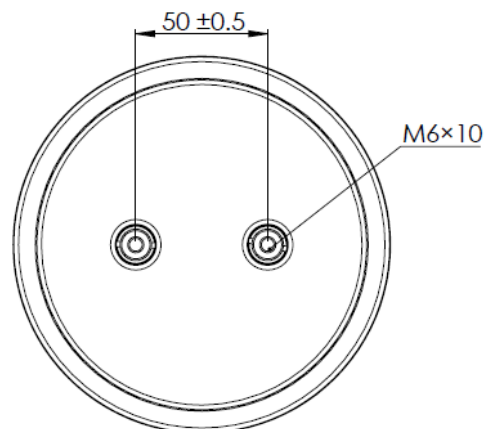
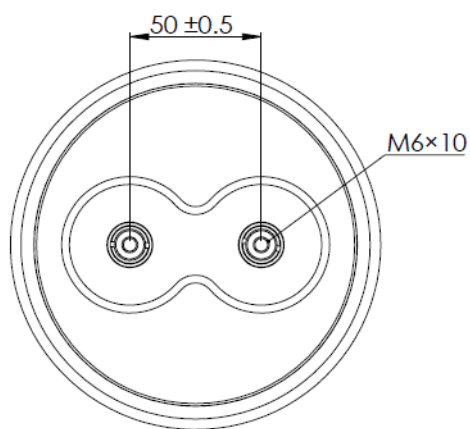
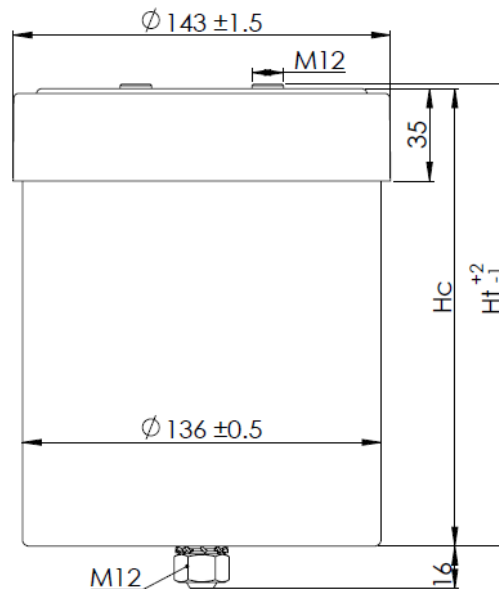
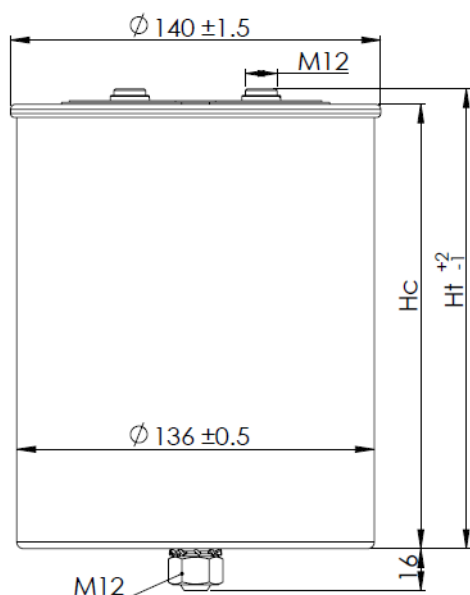

M12 stud on bottom of the aluminum case, nut (DIN 934) and toothed lock washer (DIN 6797) for fixing are standard for all types.

Terms and characteristics

The following definitions apply to power capacitors according to IEC 61071.

Rated capacitance C_R

Nominal value of the capacitance at 20 °C and measuring frequency of 100 Hz.

Rated DC voltage V_{RDC}

Maximum operating peak voltage of either polarity but of a non-reversing type wave form, for which the capacitor has been designed, for continuous operation.

Ripple voltage V_{ripple}

Peak-to-peak alternating component of the unidirectional voltage. This value must not exceed $0.28 \cdot V_{RDC}$

Maximum surge voltage V_s

Peak voltage induced by a switching or any other disturbance of the system which is allowed for a limited number of times and short period.

Insulation voltage V_i

RMS rated value of the insulation voltage of capacitive elements and terminals to case or earth. When it is not specified in the product data sheet, the insulation voltage is at least:

$$V_i = \frac{V_{RDC}}{\sqrt{2}}$$

AC voltage test between terminals and case V_{TC}

Units having all terminals insulated from the container shall be subjected for 10 s to a voltage applied between the terminals (joined together) and the container.

Maximum rate of voltage rise $(dv/dt)_{max}$

Maximum permissible repetitive rate of voltage rise of the operational voltage.

Maximum current I_{max}

Maximum rms current for continuous operation for the given frequency range and for the maximum ripple voltage. Please provide Frequency Spectrum of rms current to your sales contact.

Maximum peak current \hat{I}

Maximum permissible repetitive current amplitude during continuous operation.

Maximum peak current (\hat{I}) and maximum rate of voltage rise $(dv/dt)_{max}$ on a capacitor are related as follows:

$$\hat{I} = C \cdot (dv/dt)_{max}$$

Maximum surge current \hat{I}_s

Admissible peak current induced by a switching or any other disturbance of the system which is allowed for a limited number of times and short period.

$$\hat{I}_s = C \cdot (dv/dt)_s$$

Ambient temperature T_A

Temperature of the surrounding air, measured at 10 cm distance and 2/3 of the case height of the capacitor.

Lowest operating temperature $T_{op,min}$

Lowest permitted ambient temperature at which a capacitor may be energized.

Maximum operating temperature $T_{op,max}$

Highest permitted capacitor temperature during operation, i.e. temperature at the hottest point of the case.

Hot-spot temperature T_{hs}

Temperature zone inside of the capacitor at hottest spot.

$$T_{hs} = T_A + I_{RMS}^2 \cdot ESR \cdot R_{th}$$

Tangent of the loss angle of a capacitor $\tan \delta$

Ratio between the equivalent series resistance and the capacitive reactance of a capacitor at a specified sinusoidal alternating voltage, frequency and temperature.

Series resistance R_s

The sum of all Ohmic resistances occurring inside the capacitor.

ESR

Effective resistance which, if connected in series with an ideal capacitor of capacitance value equal to that of the capacitor in question, would have a power loss equal to active power dissipated in that capacitor under specified operating conditions.

$$ESR = \frac{\tan \delta}{\omega \cdot C} = R_s + \frac{\tan \delta_0}{\omega \cdot C}$$

Thermal resistance R_{th}

The thermal resistance indicates by how many degrees the capacitor temperature at the hot spot rises in relation to the dissipation losses.

Maximum power loss P_{max}

Maximum permissible power dissipation for the capacitor's operation.

$$P_{max} = \frac{T_{hs} - T_A}{R_{th}}$$

Self inductance L_{self}

The sum of all inductive elements which are contained in a capacitor.

Resonance frequency f_r

The lowest frequency at which the impedance of the capacitor becomes minimum.

$$f_r = \frac{1}{2\pi \cdot \sqrt{L_{self} \cdot C_R}}$$

$V_{RDC} = 900 \text{ V DC} / V_{TT} = 1350 \text{ V DC}, 10 \text{ s} / V_{TC} = 4000 \text{ V AC}, 10 \text{ s}$

C_R μF	I_{MAX}^1 A	I_s kA	\hat{I} kA	ESR ² m Ω	L_{self} nH	f kHz	R_{TH} K/W	D mm	H_C^3 mm	H_T mm	Weight ⁴ kg	Fig.	Ordering code
350	50	8.1	2.7	1.7	≤ 35	45.5	3.3	85	99	104	0.58	1	B25680B0357K901
350	50	8.1	2.7	1.7	≤ 35	45.5	3.3	85	102	104	0.61	2	B25680C0357K901
440	65	16.2	5.4	1.1	≤ 40	37.9	2.9	116	74	79	0.88	3	B25680B0447K903
440	65	16.2	5.4	1.1	≤ 40	37.9	2.9	116	77	79	0.92	4	B25680C0447K903
480	55	8.1	2.7	2.1	≤ 40	36.3	2.9	85	124	129	0.71	1	B25680B0487K901
550	50	8.7	2.9	2.3	≤ 40	33.9	2.9	85	136	141	0.85	1	B25680B0557K901
600	70	15.3	5.1	1.5	≤ 40	32.5	2.4	85	156	161	1	1	B25680B0607K901
700	70	15.9	5.3	1.2	≤ 40	30.1	2.3	116	99	104	1.13	3	B25680B0707K903
750	75	17.4	5.8	1.6	≤ 60	23.7	2.3	85	179	184	1.1	1	B25680B0757K901
900	75	14.1	4.7	1.6	≤ 60	21.7	2.2	85	229	234	1.4	1	B25680B0907K901
970	75	16.2	5.4	1.4	≤ 40	25.6	2.2	116	124	129	1.4	3	B25680B0977K903
1100	80	16.2	5.4	1.5	≤ 40	24.0	2.1	116	136	141	1.55	3	B25680B0118K903
1200	70	30.9	10.3	1	≤ 40	23.0	2.1	116	156	161	1.75	3	B25680B0128K903
1400	80	33	11	1.1	≤ 60	17.4	2	116	179	184	1.95	3	B25680B0148K903
1500	80	21.6	7.2	1.3	≤ 60	16.8	2	136	137	142	2.1	5	B25680B0158K903
1900	80	33	11	1.2	≤ 60	14.9	1.8	116	229	234	2.56	3	B25680B0198K903
2200	80	33	11	1.3	≤ 70	12.8	1.8	116	253	258	2.85	3	B25680B0228K903
2200	80	33	11	1.3	≤ 70	12.8	1.8	116	256	258	2.89	4	B25680C0228K903
3000	100	38.4	12.8	1.2	≤ 80	10.3	1.4	116	345	350	3.9	3	B25680B0308K903
3000	100	38.4	12.8	1.2	≤ 80	10.3	1.4	116	348	350	3.94	4	B25680C0308K903
3400	100	33	11	1.3	≤ 80	9.7	1.4	136	280	285	4.2	5	B25680B0348K903
3400	100	33	11	1.3	≤ 80	9.7	1.4	136	283	285	4.26	6	B25680C0348K903
4000	100	45	15	1	≤ 80	8.9	1.1	136	345	350	5.2	5	B25680B0408K903
4000	100	45	15	1	≤ 80	8.9	1.1	136	348	350	5.26	6	B25680C0408K903

¹ Please refer to current derating section for more details

² ESR at 1 kHz (typical value)

³ H_C is typical value

⁴ Weight is typical value

Other configurations and capacitance tolerances available upon request

$V_{RDC} = 1100 \text{ V DC} / V_{TT} = 1650 \text{ V DC}, 10 \text{ s} / V_{TC} = 4000 \text{ V AC}, 10 \text{ s}$

C_R μF	I_{MAX}^1 A	I_s kA	\hat{I} kA	ESR ² m Ω	L_{self} nH	f kHz	R_{TH} K/W	D mm	H_C^3 mm	H_T mm	Weight ⁴ kg	Fig.	Ordering code
230	50	6.9	2.3	1.9	≤ 35	56.1	3.3	85	99	104	0.58	1	B25680B1237K101
280	75	15.3	5.1	1.2	≤ 40	47.6	2.9	116	74	79	0.88	3	B25680B1287K103
310	50	7.8	2.6	2.3	≤ 40	45.2	2.9	85	124	129	0.71	1	B25680B1317K101
420	63	8.7	2.9	2.4	≤ 40	38.8	2.9	85	136	141	0.85	1	B25680B1427A101
420	75	15.3	5.1	1.7	≤ 40	38.8	2.4	85	156	161	1	1	B25680B1427K101
420	75	14.7	4.9	1.3	≤ 40	38.8	2.3	116	99	104	1.13	3	B25680B1427K103
480	80	15.6	5.2	1.8	≤ 60	29.7	2.3	85	179	184	1.1	1	B25680B1487K101
610	80	15	5	1.7	≤ 40	32.2	2.2	116	124	129	1.4	3	B25680B1617K103
610	80	15	5	1.7	≤ 40	32.2	2.2	116	127	129	1.44	4	B25680C1617K103
700	80	15	5	1.7	≤ 40	30.1	2.1	116	136	141	1.55	3	B25680B1707K103
700	80	15	5	1.7	≤ 40	30.1	2.1	116	139	141	1.59	4	B25680C1707K103
900	100	29.7	9.9	1.2	≤ 60	21.7	2	116	179	184	1.95	3	B25680B1907K103
900	100	29.7	9.9	1.2	≤ 60	21.7	2	116	182	184	1.99	4	B25680C1907K103
950	80	19.5	6.5	1.5	≤ 60	21.1	2	136	137	142	2.1	5	B25680B1957K103
950	80	19.5	6.5	1.5	≤ 60	21.1	2	136	140	142	2.16	6	B25680C1957K103
1500	100	29.1	9.7	1.5	≤ 80	14.5	1.7	116	279	284	3.13	3	B25680B1158K103
1500	100	29.1	9.7	1.5	≤ 80	14.5	1.7	116	282	284	3.17	4	B25680C1158K103
1900	100	34.5	11.5	1.2	≤ 80	12.9	1.4	116	345	350	3.9	3	B25680B1198K103
1900	100	34.5	11.5	1.2	≤ 80	12.9	1.4	116	348	350	3.94	4	B25680C1198K103
2200	100	29.1	9.7	1.4	≤ 80	12.0	1.4	136	280	285	4.2	5	B25680B1228K103
2200	100	29.1	9.7	1.4	≤ 80	12.0	1.4	136	283	285	4.26	6	B25680C1228K103
2700	100	42	14	1	≤ 80	10.8	1.1	136	345	350	5.2	5	B25680B1278K103
2700	100	42	14	1	≤ 80	10.8	1.1	136	348	350	5.26	6	B25680C1278K103

* Capacitance tolerance A: -15% ... 0%

¹ Please refer to current derating section for more details

² ESR at 1 kHz (typical value)

³ H_C is typical value

⁴ Weight is typical value

Other configurations and capacitance tolerances available upon request

$V_{RDC} = 1200 \text{ V DC} / V_{TT} = 1800 \text{ V DC}, 10 \text{ s} / V_{TC} = 4000 \text{ V AC}, 10 \text{ s}$

C_R μF	I_{MAX}^1 A	I_s kA	\hat{I} kA	ESR ² m Ω	L_{self} nH	f kHz	R_{TH} K/W	D mm	H_C^3 mm	H_T mm	Weight ⁴ kg	Fig.	Ordering code
180	50	6.9	2.3	2.1	≤ 35	63.4	3.3	85	99	104	0.58	1	B25680B1187K201
250	50	7.2	2.4	2.4	≤ 40	50.3	2.9	85	124	129	0.71	1	B25680B1257K201
280	50	7.2	2.4	2.5	≤ 40	47.6	2.9	85	136	141	0.85	1	B25680B1287K201
300	65	14.1	4.7	1.8	≤ 40	45.9	2.4	85	156	161	1	1	B25680B1307K201
350	65	13.5	4.5	1.9	≤ 60	34.7	2.3	85	179	184	1.1	1	B25680B1357K201
350	65	13.5	4.5	1.9	≤ 60	34.7	2.3	85	182	184	1.13	2	B25680C1357K201
360	70	14.7	4.9	1.6	≤ 40	41.9	2.3	116	99	104	1.13	3	B25680B1367K203
360	70	14.7	4.9	1.6	≤ 40	41.9	2.3	116	102	104	1.17	4	B25680C1367K203
500	75	15	5	1.7	≤ 40	35.6	2.2	116	124	129	1.4	3	B25680B1507K203
500	75	15	5	1.7	≤ 40	35.6	2.2	116	127	129	1.44	4	B25680C1507K203
520	70	13.8	4.6	1.6	≤ 60	28.5	2.2	85	229	234	1.4	1	B25680B1527K201
520	70	13.8	4.6	1.6	≤ 60	28.5	2.2	85	232	234	1.43	2	B25680C1527K201
570	75	15	5	1.7	≤ 40	33.3	2.1	116	136	141	1.55	3	B25680B1577K203
570	75	15	5	1.7	≤ 40	33.3	2.1	116	139	141	1.59	4	B25680C1577K203
620	80	29.1	9.7	1.3	≤ 60	26.1	2.1	116	156	161	1.75	3	B25680B1627K203
620	80	29.1	9.7	1.3	≤ 60	26.1	2.1	116	159	161	1.79	4	B25680C1627K203
730	100	29.4	9.8	1.3	≤ 60	24.0	2	116	179	184	1.95	3	B25680B1737K203
730	100	29.4	9.8	1.3	≤ 60	24.0	2	116	182	184	1.99	4	B25680C1737K203
800	75	19.5	6.5	1.5	≤ 60	23.0	2	136	137	142	2.1	5	B25680B1807K203
800	75	19.5	6.5	1.5	≤ 60	23.0	2	136	140	142	2.16	6	B25680C1807K203
1500	100	34.5	11.5	1.3	≤ 80	14.5	1.4	116	345	350	3.9	3	B25680B1158K203
1500	100	34.5	11.5	1.3	≤ 80	14.5	1.4	116	348	350	3.94	4	B25680C1158K203
2200	100	42	14	1	≤ 80	12.0	1.1	136	345	350	5.2	5	B25680B1228K203
2200	100	42	14	1	≤ 80	12.0	1.1	136	348	350	5.26	6	B25680C1228K203

¹ Please refer to current derating section for more details

² ESR at 1 kHz (typical value)

³ Hc is typical value

⁴ Weight is typical value

Other configurations and capacitance tolerances available upon request

$V_{RDC} = 1320 \text{ V DC} / V_{TT} = 1980 \text{ V DC}, 10 \text{ s} / V_{TC} = 4000 \text{ V AC}, 10 \text{ s}$

C_R μF	I_{MAX}^1 A	I_s kA	\hat{I} kA	ESR ² m Ω	L_{self} nH	f kHz	R_{TH} K/W	D mm	H_C^3 mm	H_T mm	Weight ⁴ kg	Fig.	Ordering code
160	48	6.9	2.3	2.3	≤ 35	67.3	3.3	85	99	104	0.58	1	B25680B1167K321
220	45	7.2	2.4	2.6	≤ 40	53.7	2.9	85	124	129	0.71	1	B25680B1227K321
250	45	7.2	2.4	2.7	≤ 40	50.3	2.9	85	136	141	0.85	1	B25680B1257K321
300	65	14.4	4.8	1.7	≤ 40	45.9	2.3	116	99	104	1.13	3	B25680B1307K323
320	70	13.2	4.4	2.1	≤ 60	36.3	2.3	85	179	184	1.1	1	B25680B1327K321
320	70	13.2	4.4	2.1	≤ 60	36.3	2.3	85	182	184	1.13	2	B25680C1327K321
400	70	12.3	4.1	2.2	≤ 60	32.5	2.2	85	229	234	1.4	1	B25680B1407K321
400	70	12.3	4.1	2.2	≤ 60	32.5	2.2	85	232	234	1.43	2	B25680C1407K321
420	65	14.1	4.7	1.8	≤ 40	38.8	2.2	116	124	129	1.4	3	B25680B1427K323
420	65	14.1	4.7	1.8	≤ 40	38.8	2.2	116	127	129	1.44	4	B25680C1427K323
470	70	14.1	4.7	1.8	≤ 40	36.7	2.1	116	136	141	1.55	3	B25680B1477K323
470	70	14.1	4.7	1.8	≤ 40	36.7	2.1	116	139	141	1.59	4	B25680C1477K323
500	80	26.7	8.9	1.4	≤ 60	29.1	2.1	116	156	161	1.75	3	B25680B1507K323
500	80	26.7	8.9	1.4	≤ 60	29.1	2.1	116	159	161	1.79	4	B25680C1507K323
610	100	27.9	9.3	1.4	≤ 60	26.3	2	116	179	184	1.95	3	B25680B1617K323
610	100	27.9	9.3	1.4	≤ 60	26.3	2	116	182	184	1.99	4	B25680C1617K323
650	70	18.6	6.2	1.8	≤ 60	25.5	2	136	137	142	2.1	5	B25680B1657K323
650	70	18.6	6.2	1.8	≤ 60	25.5	2	136	140	142	2.16	6	B25680C1657K323
850	100	27.3	9.1	1.6	≤ 70	20.6	1.8	116	229	234	2.56	3	B25680B1857K323
850	100	27.3	9.1	1.6	≤ 70	20.6	1.8	116	232	234	2.6	4	B25680C1857K323
1250	100	33.3	11.1	1.4	≤ 80	15.9	1.4	116	345	350	3.9	3	B25680B1128K323
1250	100	33.3	11.1	1.4	≤ 80	15.9	1.4	116	348	350	3.94	4	B25680C1128K323
1800	100	39	13	1.1	≤ 80	13.3	1.1	136	345	350	5.2	5	B25680B1188K323
1800	100	39	13	1.1	≤ 80	13.3	1.1	136	348	350	5.26	6	B25680C1188K323

¹ Please refer to current derating section for more details

² ESR at 1 kHz (typical value)

³ H_C is typical value

⁴ Weight is typical value

Other configurations and capacitance tolerances available upon request

$V_{RDC} = 1500 \text{ V DC} / V_{TT} = 2250 \text{ V DC}, 10 \text{ s} / V_{TC} = 4000 \text{ V AC}, 10 \text{ s}$

C_R	I_{MAX}^1	I_s	\hat{I}	ESR ²	L_{self}	f	R_{TH}	D	H_C^3	H_T	Weight ⁴	Fig.	Ordering code
μF	A	kA	kA	m Ω	nH	kHz	K/W	mm	mm	mm	kg		
130	40	6.3	2.1	2.6	≤ 35	74.6	3.3	85	99	104	0.58	1	B25680B1137K501*
180	40	6.3	2.1	2.8	≤ 40	59.3	2.9	85	124	129	0.71	1	B25680B1187K501*
210	40	6.6	2.2	2.7	≤ 40	54.9	2.9	85	136	141	0.85	1	B25680B1217K501*
220	50	12.9	4.3	2.3	≤ 40	53.7	2.4	85	156	161	1	1	B25680B1227K501*
260	50	12.3	4.1	1.8	≤ 40	49.4	2.3	116	99	104	1.13	3	B25680B1267K503*
270	50	12.9	4.3	2.3	≤ 60	39.5	2.3	85	179	184	1.1	1	B25680B1277K501*
360	50	12.6	4.2	2.3	≤ 40	41.9	2.2	116	124	129	1.4	3	B25680B1367K503*
360	50	12.6	4.2	2.3	≤ 40	41.9	2.2	116	127	129	1.44	4	B25680C1367K503*
370	70	12.3	4.1	2.5	≤ 60	33.8	2.2	85	229	234	1.4	1	B25680B1377K501
370	70	12.3	4.1	2.5	≤ 60	33.8	2.2	85	232	234	1.43	2	B25680C1377K501
410	50	12.6	4.2	2.3	≤ 40	39.3	2.1	116	136	141	1.55	3	B25680B1417K503*
410	50	12.6	4.2	2.3	≤ 40	39.3	2.1	116	139	141	1.59	4	B25680C1417K503*
420	60	25.2	8.4	1.7	≤ 60	31.7	2.1	116	156	161	1.75	3	B25680B1427K503
420	60	25.2	8.4	1.7	≤ 60	31.7	2.1	116	159	161	1.79	4	B25680C1427K503
520	60	25.2	8.4	1.6	≤ 60	28.5	2	116	179	184	1.95	3	B25680B1527K503
520	60	25.2	8.4	1.6	≤ 60	28.5	2	116	182	184	1.99	4	B25680C1527K503
570	50	16.5	5.5	2	≤ 60	27.2	2	136	137	142	2.1	5	B25680B1577K503*
570	50	16.5	5.5	2	≤ 60	27.2	2	136	140	142	2.16	6	B25680C1577K503*
720	80	24.9	8.3	1.8	≤ 70	22.4	1.8	116	229	234	2.56	3	B25680B1727K503
720	80	24.9	8.3	1.8	≤ 70	22.4	1.8	116	232	234	2.6	4	B25680C1727K503
1050	100	33.3	11.1	1.5	≤ 80	17.4	1.4	116	345	350	3.9	3	B25680B1108K503
1050	100	33.3	11.1	1.5	≤ 80	17.4	1.4	116	348	350	3.94	4	B25680C1108K503
1500	100	36	12	1.1	≤ 80	14.5	1.1	136	345	350	5.2	5	B25680B1158K503
1500	100	36	12	1.1	≤ 80	14.5	1.1	136	348	350	5.26	6	B25680C1158K503

¹ Please refer to current derating section for more details

² ESR at 1 kHz (typical value)

³ Hc is typical value

⁴ Weight is typical value

Other configurations and capacitance tolerances available upon request

*** This Part Number is affected by "Dual Use" regulations according to Export Control law. Deliveries of such products are subject to prior approval by Export Control authorities based on customer declarations. The delivery to certain countries might be restricted.**

$V_{RDC} = 2000 \text{ V DC} / V_{TT} = 3000 \text{ V DC}, 10 \text{ s} / V_{TC} = 4000 \text{ V AC}, 10 \text{ s}$

C_R μF	I_{MAX}^1 A	I_s kA	\hat{I} kA	ESR ² mΩ	L_{self} nH	f kHz	R_{TH} K/W	D mm	H_C^3 mm	H_T mm	Weight ⁴ kg	Fig.	Ordering code
70	40	4.8	1.6	3.5	≤ 35	101.7	3.3	85	99	104	0.58	1	B25680B2706K001*
70	40	4.8	1.6	3.5	≤ 35	101.7	3.3	85	102	104	0.61	2	B25680C2706K001*
95	40	4.8	1.6	3.6	≤ 40	81.6	2.9	85	124	129	0.71	1	B25680B2956K001*
95	40	4.8	1.6	3.6	≤ 40	81.6	2.9	85	127	129	0.74	2	B25680C2956K001*
110	40	4.5	1.5	3.6	≤ 40	75.9	2.9	85	136	141	0.85	1	B25680B2117K001*
110	40	4.5	1.5	3.6	≤ 40	75.9	2.9	85	139	141	0.88	2	B25680C2117K001*
130	50	10.2	3.4	2.7	≤ 60	57.0	2.3	85	179	184	1.1	1	B25680B2137K001*
130	50	10.2	3.4	2.7	≤ 60	57.0	2.3	85	182	184	1.13	2	B25680C2137K001*
180	60	9.6	3.2	2.8	≤ 40	59.3	2.2	116	124	129	1.4	3	B25680B2187K003*
180	60	9.6	3.2	2.8	≤ 40	59.3	2.2	116	127	129	1.44	4	B25680C2187K003*
190	70	9.3	3.1	2.8	≤ 60	47.1	2.2	85	229	234	1.4	1	B25680B2197K001
190	70	9.3	3.1	2.8	≤ 60	47.1	2.2	85	232	234	1.43	2	B25680C2197K001
205	60	9.6	3.2	2.9	≤ 40	55.6	2.1	116	136	141	1.55	3	B25680B2207K003*
205	60	9.6	3.2	2.9	≤ 40	55.6	2.1	116	139	141	1.59	4	B25680C2207K003*
210	80	17.7	5.9	1.8	≤ 60	44.8	2.1	116	156	161	1.75	3	B25680B2217K003
210	80	17.7	5.9	1.8	≤ 60	44.8	2.1	116	159	161	1.79	4	B25680C2217K003
260	80	18.9	6.3	1.9	≤ 60	40.3	2	116	179	184	1.95	3	B25680B2267K003
260	80	18.9	6.3	1.9	≤ 60	40.3	2	116	182	184	1.99	4	B25680C2267K003
290	60	12.6	4.2	2.7	≤ 60	38.2	2	136	137	142	2.1	5	B25680B2297K003*
290	60	12.6	4.2	2.7	≤ 60	38.2	2	136	140	142	2.16	6	B25680C2297K003*
470	100	19.2	6.4	3	≤ 80	26.0	1.7	116	279	284	3.13	3	B25680B2477K003
470	100	19.2	6.4	3	≤ 80	26.0	1.7	116	282	284	3.17	4	B25680C2477K003
800	100	27	9	1.1	≤ 80	19.9	1.1	136	345	350	5.2	5	B25680B2807K003
800	100	27	9	1.1	≤ 80	19.9	1.1	136	348	350	5.26	6	B25680C2807K003

¹ Please refer to current derating section for more details

² ESR at 1 kHz (typical value)

³ Hc is typical value

⁴ Weight is typical value

Other configurations and capacitance tolerances available upon request

*** This Part Number is affected by "Dual Use" regulations according to Export Control law. Deliveries of such products are subject to prior approval by Export Control authorities based on customer declarations. The delivery to certain countries might be restricted.**

$V_{RDC} = 2800 \text{ V DC} / V_{TT} = 4200 \text{ V DC}, 10 \text{ s} / V_{TC} = 5000 \text{ V AC}, 10 \text{ s}$

C_R μF	I_{MAX}^1 A	I_s kA	\hat{I} kA	ESR ² m Ω	L_{self} nH	f kHz	R_{TH} K/W	D mm	H_C^3 mm	H_T mm	Weight ⁴ kg	Fig.	Ordering code
60	60	10.2	3.4	2.8	≤ 60	83.9	2.3	85	179	184	1.1	1	B25680B2606K801*
60	60	10.2	3.4	2.8	≤ 60	83.9	2.3	85	182	184	1.13	2	B25680C2606K801*
85	60	9	3	2.9	≤ 60	70.5	2.2	85	229	234	1.4	1	B25680B2856K801
85	60	9	3	2.9	≤ 60	70.5	2.2	85	232	234	1.43	2	B25680C2856K801
120	70	19.5	6.5	2	≤ 60	59.3	2	116	179	184	1.95	3	B25680B2127K803
120	70	19.5	6.5	2	≤ 60	59.3	2	116	182	184	1.99	4	B25680C2127K803
165	70	19.8	6.6	2.5	≤ 70	46.8	1.8	116	229	234	2.56	3	B25680B2167K803
165	70	19.8	6.6	2.5	≤ 70	46.8	1.8	116	232	234	2.6	4	B25680C2167K803
250	100	27	9	2.6	≤ 80	35.6	1.4	116	345	350	3.9	3	B25680B2257K803
250	100	27	9	2.6	≤ 80	35.6	1.4	116	348	350	3.94	4	B25680C2257K803
425	100	26.1	8.7	1.1	≤ 80	27.3	1.1	136	345	350	5.2	5	B25680B2427K803
425	100	26.1	8.7	1.1	≤ 80	27.3	1.1	136	348	350	5.26	6	B25680C2427K803
470	100	24	8	1.2	≤ 90	24.5	1.1	136	365	370	5.5	5	B25680B2477K803
470	100	24	8	1.2	≤ 90	24.5	1.1	136	368	370	5.56	6	B25680C2477K803

¹ Please refer to current derating section for more details

² ESR at 1 kHz (typical value)

³ H_C is typical value

⁴ Weight is typical value

Other configurations and capacitance tolerances available upon request

*** This Part Number is affected by "Dual Use" regulations according to Export Control law. Deliveries of such products are subject to prior approval by Export Control authorities based on customer declarations. The delivery to certain countries might be restricted.**

$V_{RDC} = 3000 \text{ V DC} / V_{TT} = 4500 \text{ V DC}, 10 \text{ s} / V_{TC} = 5250 \text{ V AC}, 10 \text{ s}$

C_R μF	I_{MAX}^1 A	I_s kA	\hat{I} kA	ESR ² m Ω	L_{self} nH	f kHz	R_{TH} K/W	D mm	H_C^3 mm	H_T mm	Weight ⁴ kg	Fig.	Ordering code
50	40	6	2	3	≤ 60	91.9	2.3	85	179	184	1.1	1	B25680B3506K001*
50	40	6	2	3	≤ 60	91.9	2.3	85	182	184	1.13	2	B25680C3506K001*
75	60	8.7	2.9	3.1	≤ 60	75.0	2.2	85	229	234	1.4	1	B25680B3756K001
75	60	8.7	2.9	3.1	≤ 60	75.0	2.2	85	232	234	1.43	2	B25680C3756K001
100	70	9	3	2.1	≤ 60	65.0	2	116	179	184	1.95	3	B25680B3107K003
100	70	9	3	2.1	≤ 60	65.0	2	116	182	184	1.99	4	B25680C3107K003
140	70	16.5	5.5	2.5	≤ 70	50.8	1.8	116	229	234	2.56	3	B25680B3147K003
140	70	16.5	5.5	2.5	≤ 70	50.8	1.8	116	232	234	2.6	4	B25680C3147K003
210	100	24	8	2.7	≤ 80	38.8	1.4	116	345	350	3.9	3	B25680B3217K003
210	100	24	8	2.7	≤ 80	38.8	1.4	116	348	350	3.94	4	B25680C3217K003
380	100	26.1	8.7	1.2	≤ 80	28.9	1.1	136	345	350	5.2	5	B25680B3387K003
380	100	26.1	8.7	1.2	≤ 80	28.9	1.1	136	348	350	5.26	6	B25680C3387K003
400	100	24	8	1.3	≤ 90	26.5	1.1	136	365	370	5.5	5	B25680B3407K003
400	100	24	8	1.3	≤ 90	26.5	1.1	136	368	370	5.56	6	B25680C3407K003

¹ Please refer to current derating section for more details

² ESR at 1 kHz (typical value)

³ H_C is typical value

⁴ Weight is typical value

Other configurations and capacitance tolerances available upon request

*** This Part Number is affected by "Dual Use" regulations according to Export Control law. Deliveries of such products are subject to prior approval by Export Control authorities based on customer declarations. The delivery to certain countries might be restricted.**

Display of ordering codes for TDK Electronics products

The ordering code for one and the same product can be represented differently in data sheets, data books, other publications, on the company website, or in order-related documents such as shipping notes, order confirmations and product labels. **The varying representations of the ordering codes are due to different processes employed and do not affect the specifications of the respective products.** Detailed information can be found on the Internet under www.tdk-electronics.tdk.com/orderingcodes.

Current derating

Current derating graphs for capacitors 900 V_{RDC}

B25680B0357K901

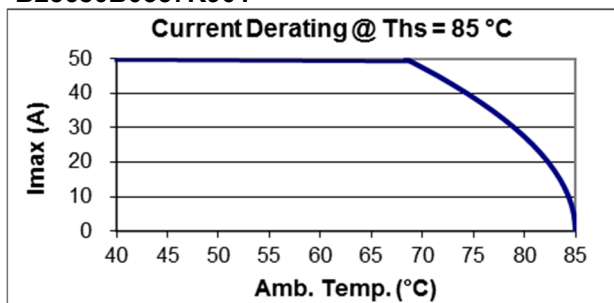

B25680B0447K903

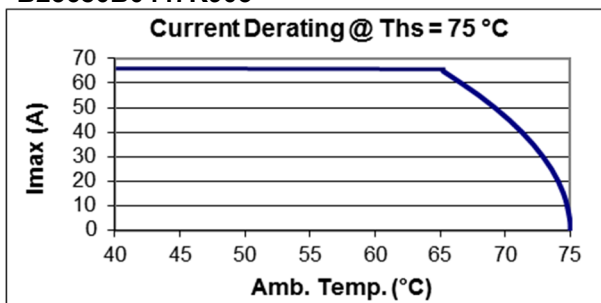

B25680B0487K901

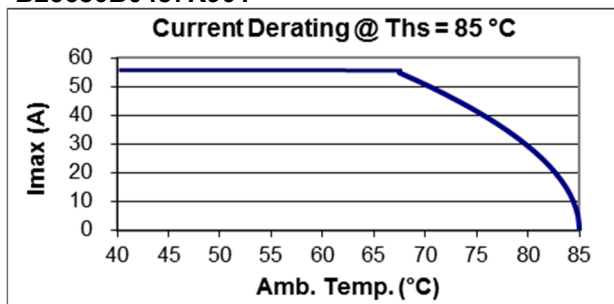

B25680B0557K901

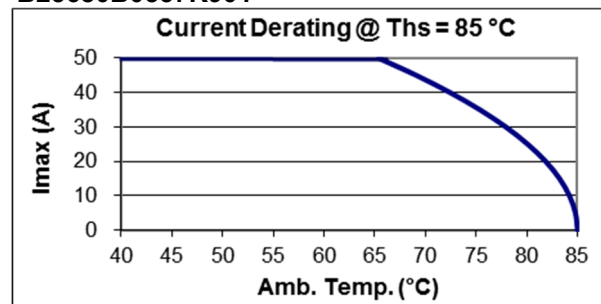

B25680B0607K901

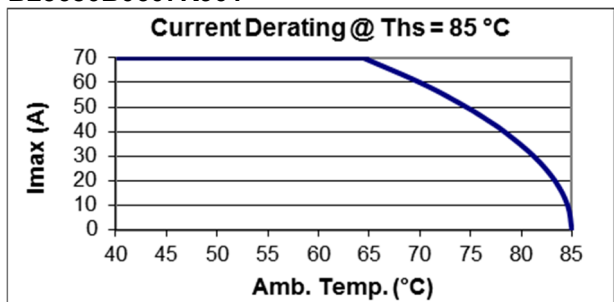

B25680B0707K903

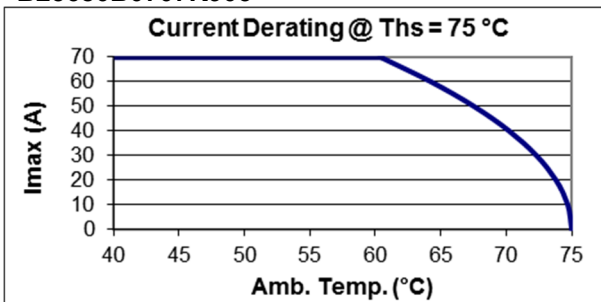

B25680B0757K901

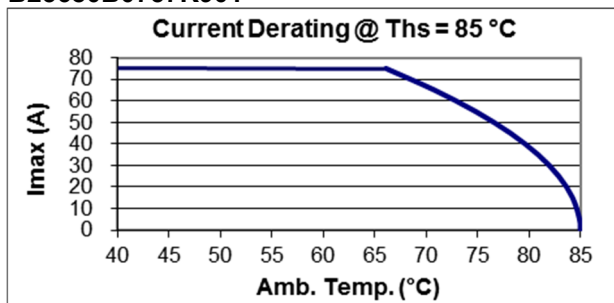

B25680B0907K901

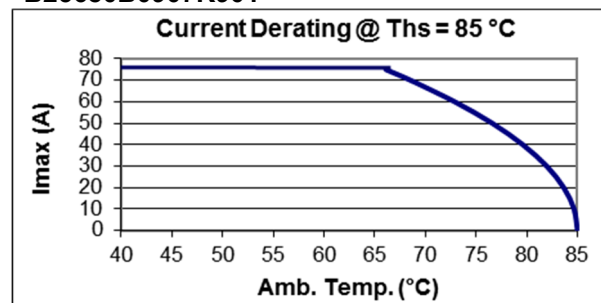

B25680B0977K903

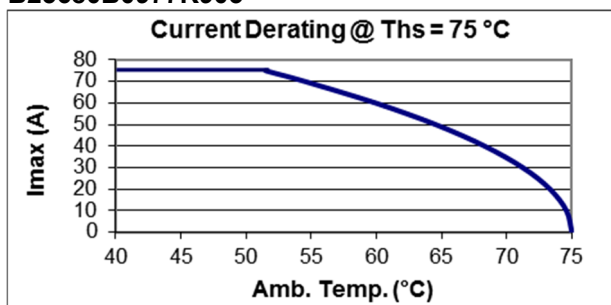

B25680B0118K903

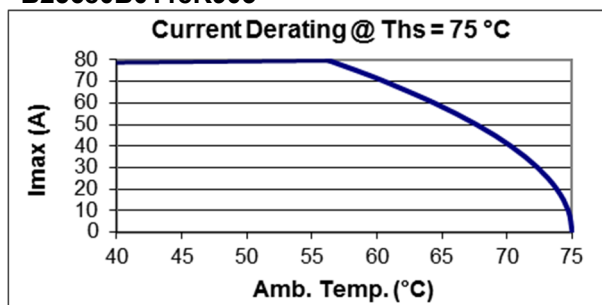

B25680B0128K903

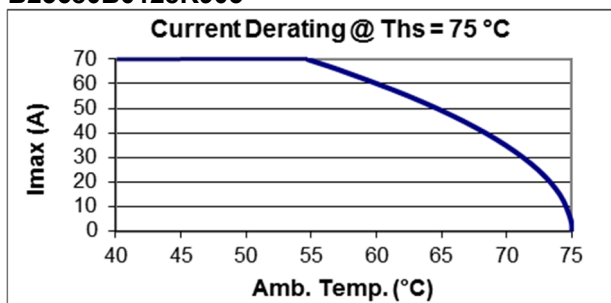

B25680B0148K903

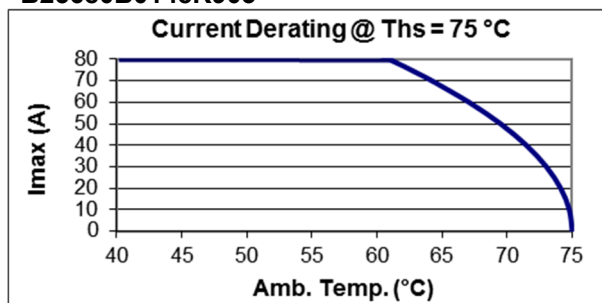

Current derating graphs for capacitors 1100 V_{RDC}

B25680B1237K101

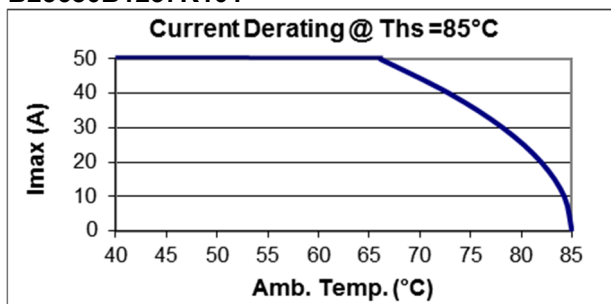

B25680B1287K103

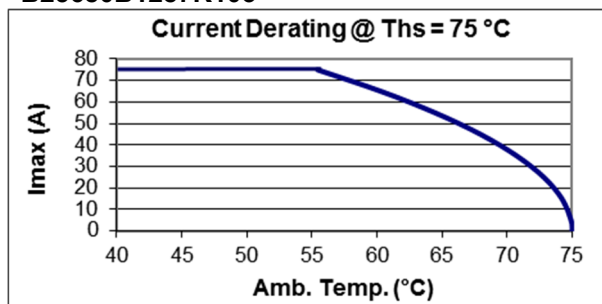

B25680B1317K101

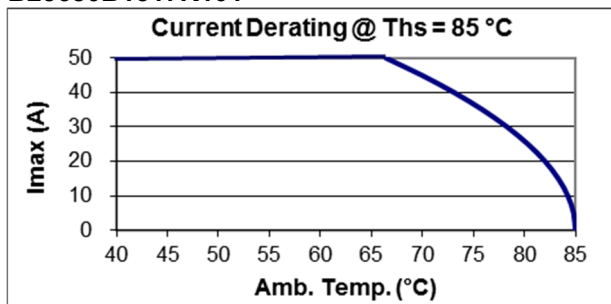

B25680B1427A101

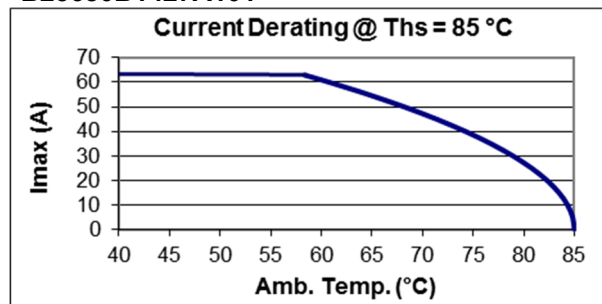

B25680B1427K101

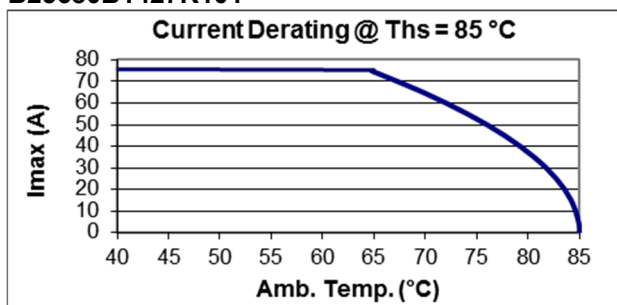

B25680B1427K103

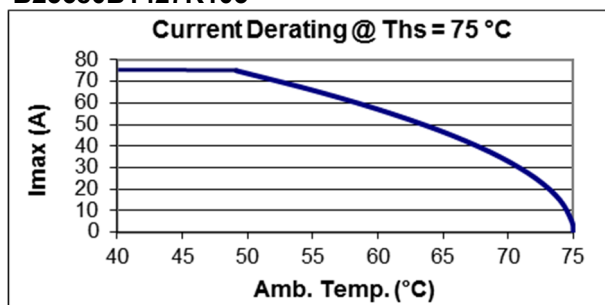

B25680B1487K101

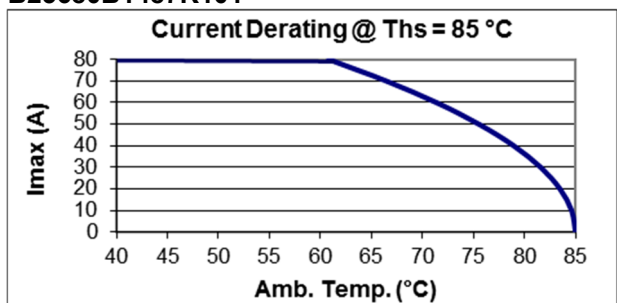

B25680B1617K103

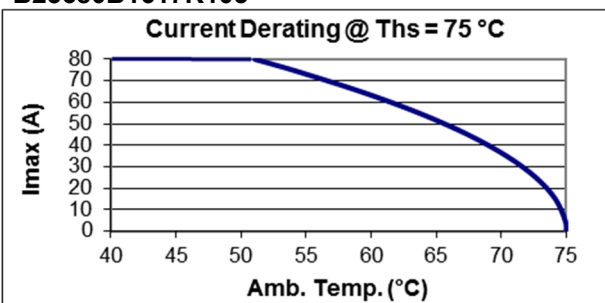

B25680B1707K103

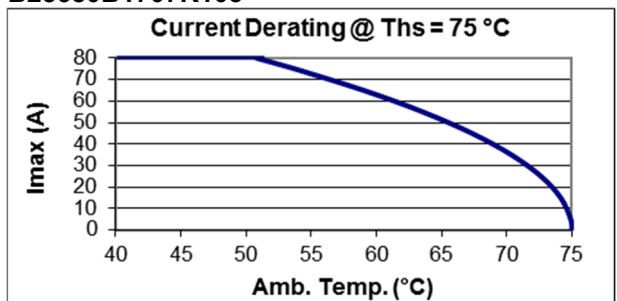

B25680B1907K103

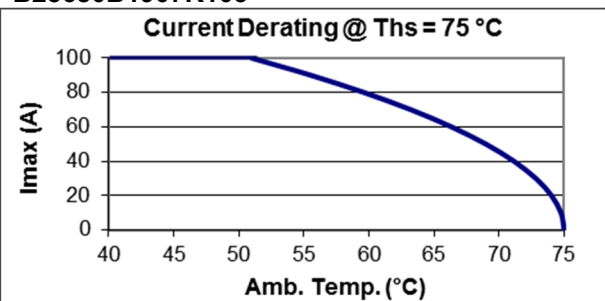

Current derating graphs for capacitors 1200 V_{RDC}

B25680B1187K201

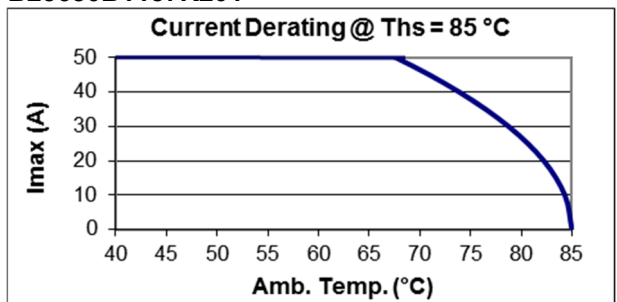

B25680B1257K201

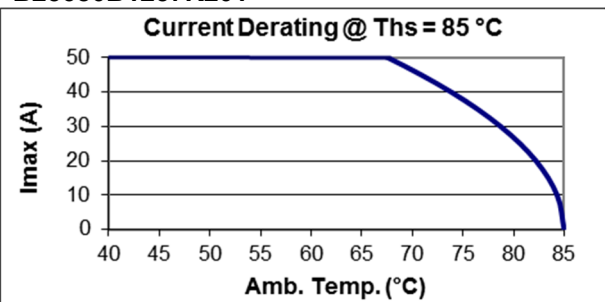

B25680B1287K201

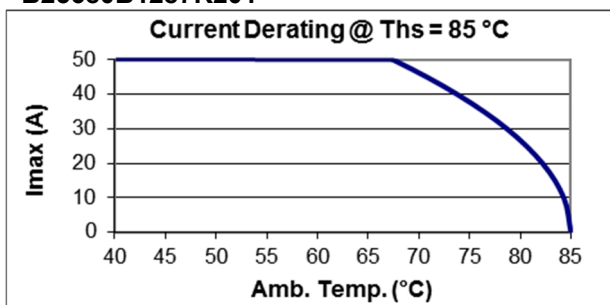

B25680B1307K201

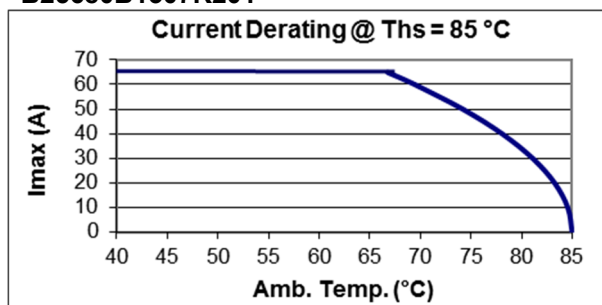

B25680B1357K201

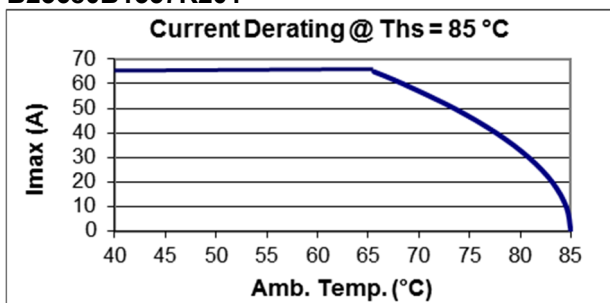

B25680B1367K203

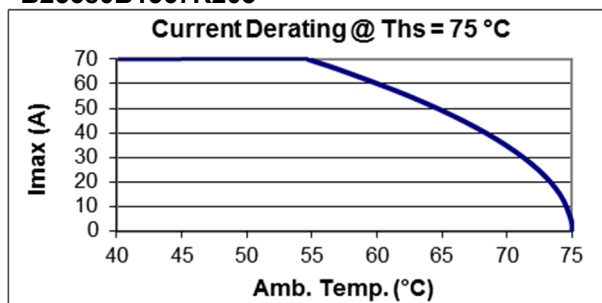

B25680B1507K203

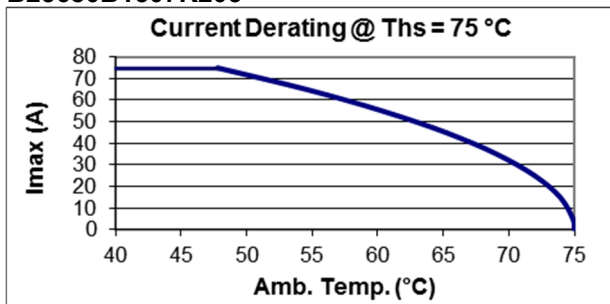

B25680B1527K201

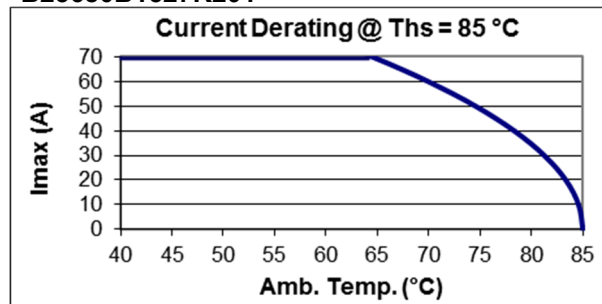

B25680B1577K203

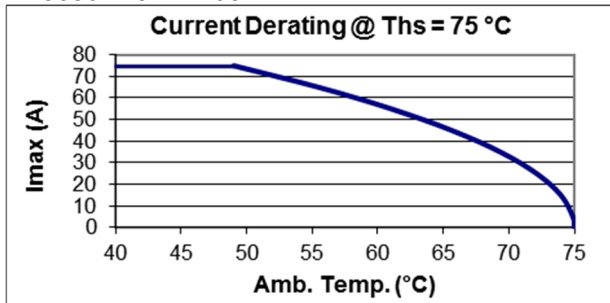

B25680B1627K203

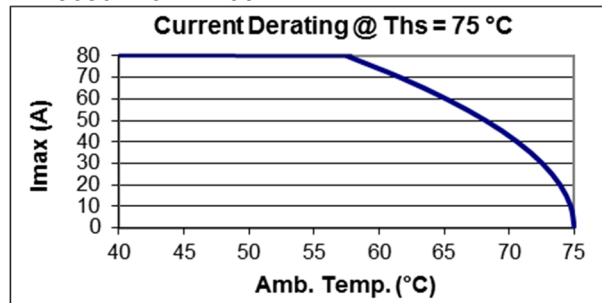

B25680B1737K203

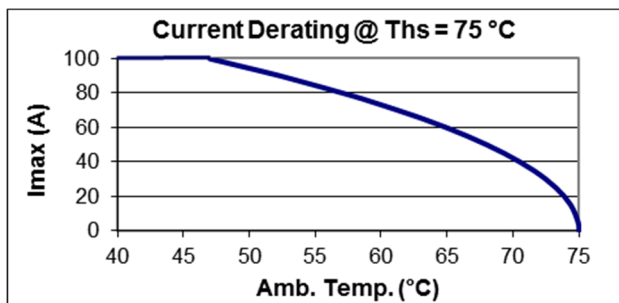

Current derating graphs are based on typical values. More graphs for capacitors are available upon request.

Service life

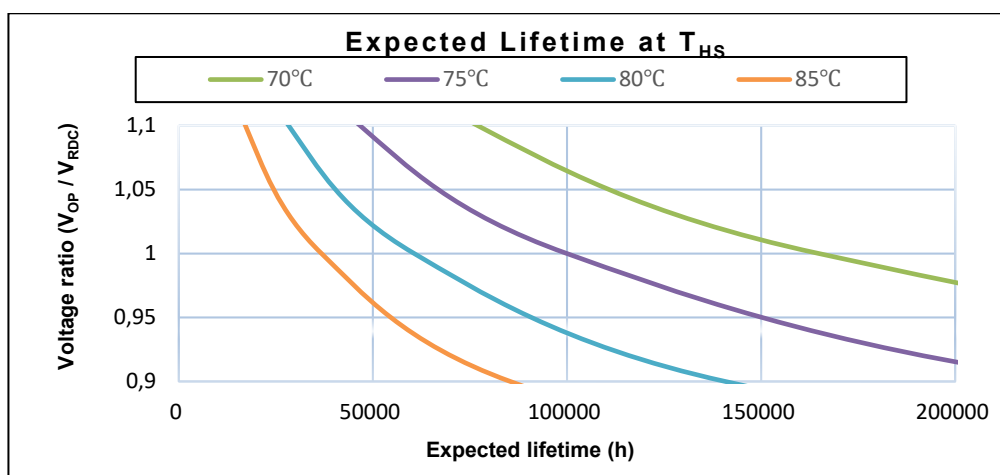

Service life t_{LD} in hours at different hotspot temperature (T_{hs}) and voltage V_{RDC} for $\varnothing D \leq 116\text{ mm}$ and $V_{RDC} \leq 2000\text{ V}$

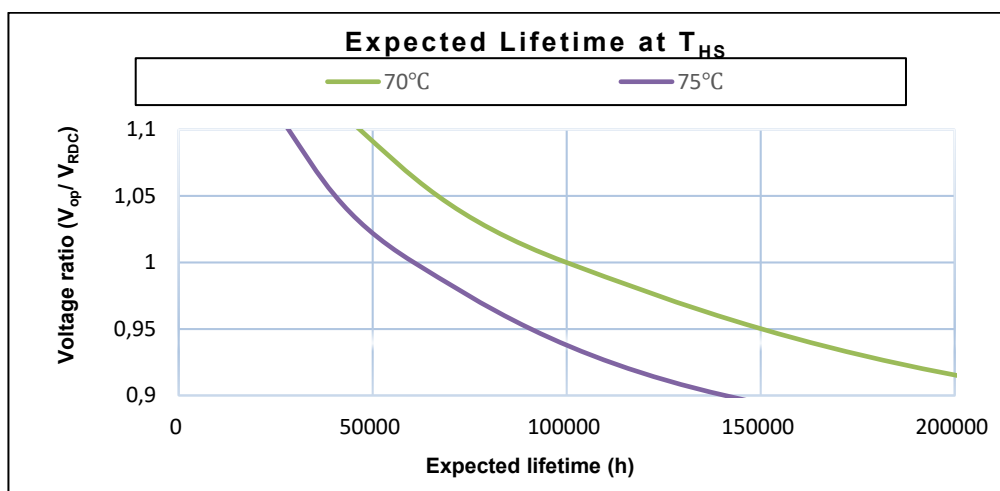

Service life t_{LD} in hours at different hotspot temperature (T_{hs}) and voltage V_{RDC} for $\varnothing D = 136\text{ mm}$ or $V_{RDC} > 2000\text{ V}$

For capacitors with diameter 116mm a maximum hot spot temperature of 85°C or capacitor with diameter 136 mm a maximum hot spot temperature of 80 °C is allowed during short term operation (maximum 10% of the total load duration) without further reduction of the service life.

Failure criteria is capacitance drop higher than 3%.

Lifetime estimations are typical theoretical values derived from lifetime tests based on TDK internal standards or mutually agreed test methods and are intended for guidance purposes only. The useful life does not constitute a warranty of any kind or a prolongation of the agreed warranty period.

Expected failure rate

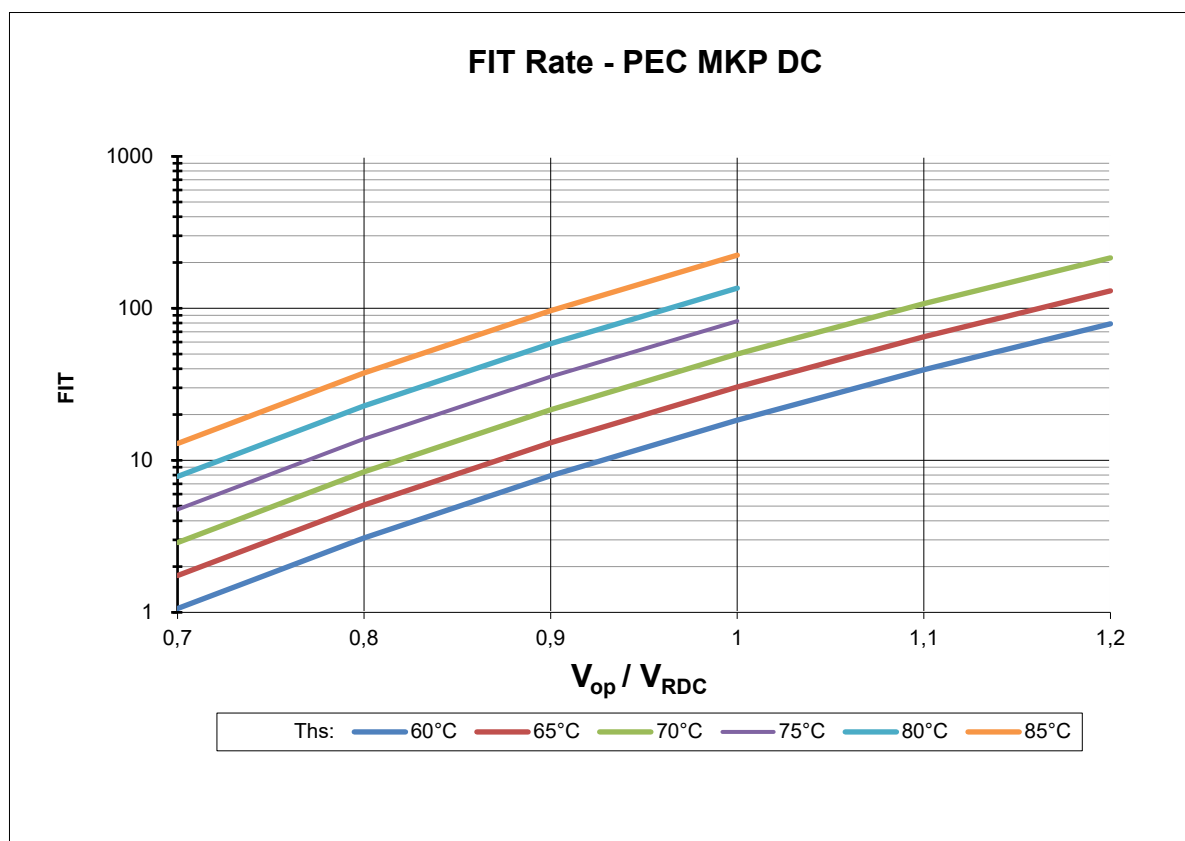

Expected Fit rate at different hot spot temperatures (T_{hs}) and voltage V_{RDC}

The FIT (Failure In Time) of a component is defined as the number of expected failures in 10^9 hours of operation. The FIT rate is calculated on the basis of the number of components operating in the field and the estimated hours of operation. All the reports of failures are taken into consideration for this calculation, which is updated every year.

The other values in the graph are given as indication and calculated based on acceleration factors.

Cautions and warnings

- In case of dents of more than 1 mm depth or any other mechanical damage, capacitors must not be used at all.
- The energy stored in capacitors may be lethal. To prevent any chance of shock, discharge and short-circuit the capacitor before handling.
- Failure to follow cautions may result, worst case, in premature failures, bursting and fire.
- Protect the capacitor properly against over current and short circuit.
- TDK Electronics is not responsible for any kind of possible damages to persons or things due to improper installation and application of capacitors for power electronics.

General safety notes for installation and operation

Electrical or mechanical misapplication of capacitors may be hazardous. Personal injury or property damage may result from bursting of the capacitor or from expulsion melted material due to mechanical disruption of the capacitor.

- Ensure good, effective grounding for capacitor enclosures.
- Observe appropriate safety precautions during operation (self-recharging phenomena and the high energy contained in capacitors).
- Handle capacitors carefully, because they may still be charged even after disconnection.
- The terminals of capacitors, connected bus bars and cables as well as other devices may also be energized.
- Follow good engineering practice.

Thermal load

After installation of the capacitor it is necessary to verify that maximum hot-spot temperature is not exceeded at extreme service conditions.

Installation

Capacitors must be installed in a cool and well ventilated place, and not close to objects that radiate heat, or in the direct sunlight. Within high-power inverter systems the capacitors usually produce the smallest portion of the total losses, and the permissible operating temperatures are low compared to power semiconductors, reactors and resistors. So, the distance between capacitor and heating sources must be large enough to avoid the capacitor overheating. In case of space constraint to make the best possible use of capacitors, technically and economically, it is advisable to supply forced cooling air.

Mechanical protection

The capacitor has to be installed in a way that mechanical damages and dents in the aluminum can are avoided.

Connecting

Ensure firm fixing of terminals, fixing torque to be applied as per individual specification. In any case, the maximum specified terminal current may not be exceeded. Please refer to the technical data of the specific series.

Grounding

The threaded bottom stud of the capacitor has to be used for grounding. In case grounding is done via metal chassis that the capacitor is mounted to, the layer of varnish beneath the washer and nut should be removed. The maximum tightening torque is 10 Nm.

Maintenance

Disregarding the following measures may result in severe operation failures, bursting and fire:

- Check tightness of the connections/terminals periodically, two weeks after installation at the latest, and then once every 6 months.
- Clean the terminals/bushings periodically to avoid short circuits due dust or other contamination.
- Take current reading twice a year and compare with nominal current. Use a harmonic analyser or true effective RMS-meter.
- In case of a current above the nominal current check your application for modification.
- Check the temperature of energized capacitors. In case of excessive temperature of individual capacitors, it is recommended to replace this capacitor, as this could be an indication for loss factor increase, which is a sign for reaching end of life.
- When power capacitors are used, suitable measures must always be taken to eliminate possible danger to humans, animals and property both during operation and when a failure occurs. This applies to capacitors both with and without protective devices. Regular inspection and maintenance by a competent person is therefore essential.

Storage and operating conditions

Do not use or store capacitors in corrosive atmosphere, especially where chloride gas, sulfide gas, acid, alkali, salt or the like are present. In dusty environments regular maintenance and cleaning especially of the terminals is required to avoid conductive path between phases and/or phases and ground.

Service life expectancy

Electrical components do not have an unlimited service life expectancy; this applies to self-healing capacitors, too. The maximum service life expectancy may vary depending on the application the capacitor is used in.

Handling

Discharge and short circuit the capacitor before handling! When handling the capacitor, do not take the capacitor from the terminal. This can cause accident in case the capacitor is charged, terminal break and capacitance loss due to capacitor is heavy.

Important notes

The following applies to all products named in this publication:

1. Some parts of this publication contain **statements about the suitability of our products for certain areas of application**. These statements are based on our knowledge of typical requirements that are often placed on our products in the areas of application concerned. We nevertheless expressly point out **that such statements cannot be regarded as binding statements about the suitability of our products for a particular customer application**. As a rule we are either unfamiliar with individual customer applications or less familiar with them than the customers themselves. For these reasons, it is always ultimately incumbent on the customer to check and decide whether a product with the properties described in the product specification is suitable for use in a particular customer application.
2. We also point out that **in individual cases, a malfunction of electronic components or failure before the end of their usual service life cannot be completely ruled out in the current state of the art, even if they are operated as specified**. In customer applications requiring a very high level of operational safety and especially in customer applications in which the malfunction or failure of an electronic component could endanger human life or health (e.g. in accident prevention or life-saving systems), it must therefore be ensured by means of suitable design of the customer application or other action taken by the customer (e.g. installation of protective circuitry or redundancy) that no injury or damage is sustained by third parties in the event of malfunction or failure of an electronic component.
3. **The warnings, cautions and product-specific notes must be observed.**
4. In order to satisfy certain technical requirements, **some of the products described in this publication may contain substances subject to restrictions in certain jurisdictions (e.g. because they are classed as hazardous)**. Useful information on this will be found in our Material Data Sheets on the Internet (www.tdk-electronics.tdk.com/material). Should you have any more detailed questions, please contact our sales offices.
5. We constantly strive to improve our products. Consequently, **the products described in this publication may change from time to time**. The same is true of the corresponding product specifications. Please check therefore to what extent product descriptions and specifications contained in this publication are still applicable before or when you place an order.

We also **reserve the right to discontinue production and delivery of products**. Consequently, we cannot guarantee that all products named in this publication will always be available. The aforementioned does not apply in the case of individual agreements deviating from the foregoing for customer-specific products.

6. Unless otherwise agreed in individual contracts, **all orders are subject to our General Terms and Conditions of Supply**.
7. **Our manufacturing sites serving the automotive business apply the IATF 16949 standard**. The IATF certifications confirm our compliance with requirements regarding the quality management system in the automotive industry. Referring to customer requirements and customer specific requirements ("CSR") TDK always has and will continue to have the policy of respecting individual agreements. Even if IATF 16949 may appear to support the acceptance of unilateral requirements, we hereby like to emphasize that **only requirements mutually agreed upon can and will be implemented in our Quality Management System**. For clarification purposes we like to point out that obligations from IATF 16949 shall only become legally binding if individually agreed upon.

Important notes

8. The trade names EPCOS, CarXield, CeraCharge, CeraDiode, CeraLink, CeraPad, CeraPlas, CSMP, CTVS, DeltaCap, DigiSiMic, FilterCap, FormFit, InsuGate, LeaXield, MediPlas, MiniBlue, MiniCell, MKD, MKK, ModCap, MotorCap, PCC, PhaseCap, PhaseCube, PhaseMod, PhiCap, PiezoBrush, PlasmaBrush, PowerHap, PQSine, PQvar, SIFERRIT, SIFI, SIKOREL, SilverCap, SIMDAD, SiMic, SIMID, SineFormer, SIOV, SurfIND, ThermoFuse, WindCap, XieldCap are **trademarks registered or pending** in Europe and in other countries. Further information will be found on the Internet at www.tdk-electronics.tdk.com/trademarks.

Release 2024-02