

# SCHRACK POWER PCB RELAY RZH 105°C 16A

## GENERAL PURPOSE PCB RELAYS

### INTRODUCTION

The SCHRACK Power PCB Relay RZH 105°C 16A is a versatile and robust relay designed for general-purpose applications. Featuring a single pole with 16A capacity and reinforced insulation, it ensures reliable performance even at high ambient temperatures of up to 105°C. This relay's low-profile package, high dielectric strength, and wide range of coil voltages make it ideal for industrial automation, HVAC systems, and high-temperature control applications such as ovens and cooking plates.

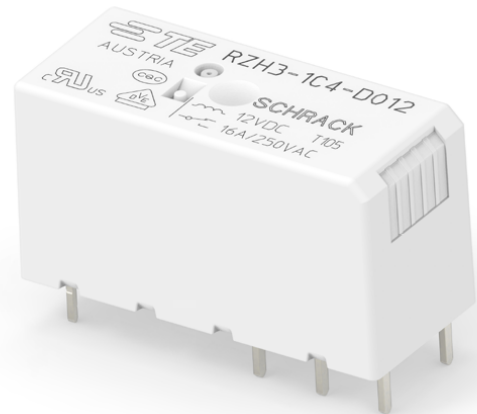

### FEATURES

- 1 pole 16A, 1 form C (CO) or 1 form A (NO) contact
- DC coil 400mW
- 5kV/10mm coil-contact, reinforced insulation
- Ambient temperature 105°C
- Product in accordance to IEC 60335-1

### APPLICATIONS

- Oven control
- Cooking plate control

### APPROVALS

- VDE Cert. No. 40023970
- cULus E214025
- CQC 12002066685



Technical data of approved types on request

# SCHRACK POWER PCB RELAY RZH 105°C 16A

GENERAL PURPOSE RELAYS PCB RELAYS

## CONTACT DATA

Contact arrangement	1 form C (CO) or 1 form A (NO)
Rated voltage	250VAC
Max. switching voltage	400VAC
Rated current	16A
Limiting making current, form A contact, max. 4s, duty factor 10 %	30A
Breaking capacity max.	4000VA
Contact material	AgNi 90/10 or AgSnO <sub>2</sub>
Frequency of operation, with/without load	360/72000h <sup>-1</sup>
Operate/release time max.	8/6ms
Bounce time max., form A/form B	4/6ms

## CONTACT RATINGS

Type	Contact	Load	Cycles
<b>Standard version</b>			
<b>IEC 61810</b>			
RZH3-1C4	A/C (NO/NC)	16 A, 250 VAC, 105°C	10x10 <sup>3</sup>
RZH3-1A3	A (NO)	16 A, 250 VAC, 85°C	40x10 <sup>3</sup>
RZH3-1A3	A (NO)	12 A, 250 VAC, 105°C	20x 10 <sup>3</sup>
RZH . -1A4	A (NO)	10 A, 250 VAC, 105°C	150x10 <sup>3</sup>
RZHH-1A4	A (NO)	12 A, 250 VAC, 85°C	150x10 <sup>3</sup>
RZHH-1A4	A (NO)	18 A, 250 VAC, 85°C	30x10 <sup>3</sup>
RZHH-1A4	A (NO)	12 A, 250 VAC, 105°C	100x10 <sup>3</sup>
RZHH-1A4	A (NO)	10 A, 250 VAC, 105°C	300x10 <sup>3</sup>
RZHH-1A4	A (NO)	16 A, 250 VAC, 105°C	30x10 <sup>3</sup>
RZH . -1A4	A (NO)	16 A, 250 VAC, 85°C	50x10 <sup>3</sup>
<b>UL 61810-1 (former UL 508)</b>			
RZH3-1A4	A (NO)	10 A, 250 VAC, 105°C	150x10 <sup>3</sup>
RZH3-1C4	A/C (NO/NC)	16 A, 250 VAC, 105°C	10x10 <sup>3</sup>
RZHH-1A4	A (NO)	10 A, 250 VAC, 105°C	300x10 <sup>3</sup>
RZHH-1A4	A (NO)	12 A, 250 VAC, 105°C	150x10 <sup>3</sup>
RZHH-1A4	A (NO)	12 A, 250 VAC, 85°C	150x10 <sup>3</sup>
RZHH-1A4	A (NO)	16 A, 250 VAC, 105°C	30x10 <sup>3</sup>
RZHH-1A4	A (NO)	16 A, 250 VAC, 85°C	50x10 <sup>3</sup>

## CONTACT RATINGS

Type	Contact	Load	Cycles
<b>RZ reinforced flux proof version</b>			
<b>IEC 61810</b>			
RZHH-1A4-D...-R	A (NO)	16A, 250VAC, 105°C	30x10 <sup>3</sup>
<b>IEC 61810 (former UL 508)</b>			
RZHH-1A4-D...-R	A (NO)	16A, 277VAC, GP, 105°C	100x10 <sup>3</sup>
Mechanical endurance		>10x10 <sup>6</sup> operations	

## MAX. DC LOAD BREAKING CAPACITY

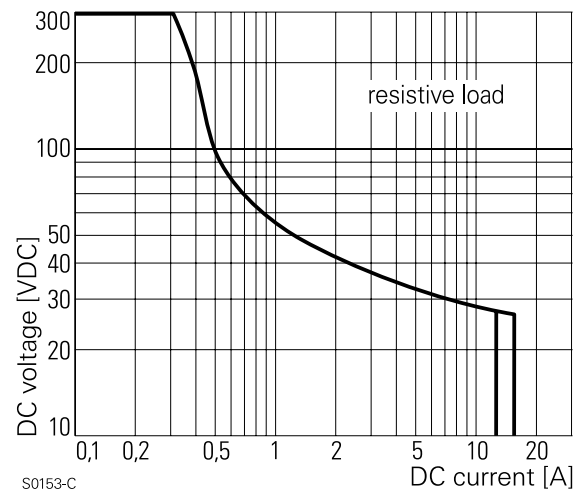

# SCHRACK POWER PCB RELAY RZH 105°C 16A

## GENERAL PURPOSE RELAYS PCB RELAYS

### COIL DATA

Coil voltage range	3 to 48VDC
Operative range, IEC 61810	90...110% $U_{RTD}$
Coil insulation system according UL1446	class F

### COIL VERSIONS, DC COIL

Coil code	Rated voltage VDC	Operate voltage VDC	Release voltage VDC	Coil resistance $\Omega \pm 10\%$	Rated coil power mW
D003	3	2.1	0.3	22	410
D005	5	3.5	0.5	60	420
D006	6	4.2	0.6	90	400
D009	9	6.3	0.9	200	400
D012	12	8.4	1.2	360	400
D024	24	16.8	2.4	1440	400
D048	48	33.6	4.8	5730	400

All figures are given for coil without pre-energization, at ambient temperature +23°C, Other coil voltages on request.

### COIL OPERATING RANGE DC

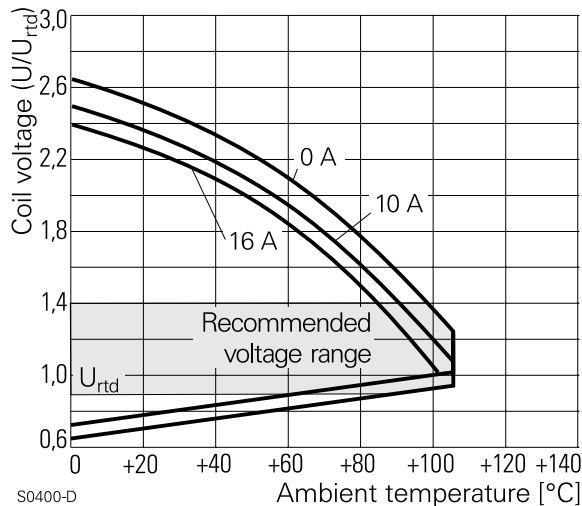

### INSULATION DATA

Initial dielectric strength	
between open contacts	1000V <sub>rms</sub>
between contact and coil	5000V <sub>rms</sub>
Clearance/creepage	
between contact and coil	≥10/10mm
Material group of insulation parts	IIIa
Tracking index of relay base	PTI 250V

### OTHER DATA

Material compliance	EU RoHS/ELV, China RoHS, REACH, Halogen content refer to the Product Compliance Support Center at <a href="http://www.te.com/customer-support/rohssupportcenter">www.te.com/customer-support/rohssupportcenter</a>
Resistance to heat and fire standard cover version	according EN 60335-1, par.30
Ambient temperature	-40 to 105°C
Category of environmental protection	
IEC 61810	RTII - flux proof
Vibration resistance (functional), 30 to 500Hz	
closing form A contact	>15g
opening form A contact	>20g
opening form B contact	>5g
Shock resistance (destructive)	100g
Terminal type	PCB-THT
Mounting distance	≥2mm
Weight	10g
Resistance to soldering heat THT	
IEC 60068-2-20	270°C/10s <sup>1)</sup>
Packaging/unit	tube/20 pcs., box/500 pcs.
suffix-00001/-R0001 & -00002/-R0002	See details C-1558100

1) The use of foaming flux is not permitted.

# SCHRACK POWER PCB RELAY RZH 105°C 16A

GENERAL PURPOSE RELAYS PCB RELAYS

## DIMENSIONS (Unit:mm)

16A, pinning 5mm

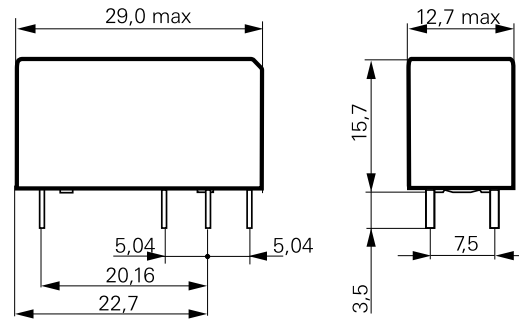

## PCB LAYOUT / TERMINAL ASSIGNMENT

Bottom view on solder pins

16A, pinning 5mm

1 form A (NO) contact

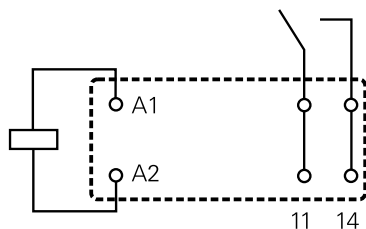

1 form C (CO) contact

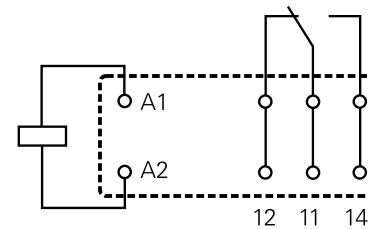

Recommended pcb hole for manual mounting:  $\varnothing 1.3\text{mm}$  For automated mounting please ask for detailed drawing.

## PRODUCT CODE STRUCTURE

**Typical product code**  
RZ H 3 -1A 4 -D012 -R

### Type

<b>RZ</b>	Power PCB Relay RZ
-----------	--------------------

### Version

<b>H</b>	Hot version 105°C
----------	-------------------

### Version

<b>3</b>	double pinning 5mm, 16A (1 form A or 1 form C)
<b>H</b>	double pinning 5mm, 16A High performance (1 form A)

### Contact Configuration

<b>1A</b>	1 form A (1 NO) contact
<b>1C</b>	1 form C (1 CO) contact

### Cover version

<b>Blank</b>	standard (hot stamped)
<b>-R</b>	reinforced flux proof (epoxy) and Plug-In capable (only AgNi contact versions)

### Coil version

<b>Coil code</b>	please refer to coil versions table
------------------	-------------------------------------

### Contact material

<b>4</b>	AgNi 90/10
<b>3</b>	AgSnO <sub>2</sub>

## PRODUCT INFORMATION

Product code	Version	Contacts	Contact material	Coll	Part Number	
					Austria	China
RZH3-1C4-D012	16A, 105°C pinning 5mm	1 form C (CO)	AgNi 90/10	12VDC	<a href="#">2-1415899-5</a>	-
RZH3-1C4-D024				24VDC	<a href="#">2-1415899-6</a>	-
RZH3-1A4-D009				9VDC	<a href="#">2-1415899-7</a>	-
RZH3-1A4-D009-R0001		1 form A (NO)		9VDC	-	<a href="#">2-2071452-6</a>
RZH3-1A4-D012				12VDC	<a href="#">2-1415899-8</a>	-
RZH3-1A4-D012-R0001				12VDC	-	<a href="#">2-2071452-7</a>
RZH3-1A4-D024				24VDC	<a href="#">2-1415899-9</a>	-
RZH3-1A4-D024-R0001				24VDC	-	<a href="#">2-2071452-8</a>
RZHH-1A4-D009				16A, 105°C pinning 5mm High performance	9VDC	<a href="#">6-1415899-2</a>
RZHH-1A4-D009-R0001	9VDC	<a href="#">2071452-8</a>	-			
RZHH-1A4-D012	12VDC	<a href="#">6-1415899-6</a>	-			
RZHH-1A4-D012-R0001	12VDC	-	<a href="#">2071452-7</a>			
RZHH-1A4-D024	24VDC	<a href="#">6-1415899-7</a>	-			
RZHH-1A4-D024-R0001	24VDC	-	<a href="#">3-2071452-2</a>			
RZH3-1A3-D012	16A, 105°C, pinning 5mm		AgSnO2	12VDC	<a href="#">9-1415899-0</a>	-

### Notes:

- Datasheets and product specification according to IEC 61810-1 and to be used only together with the 'Definitions' section.
- Datasheets and product data is subject to the terms of the disclaimer and all chapters of the 'Definitions' section, available at <http://relays.te.com/definitions>.
- Datasheets, product data, 'Definitions' section, application notes and all specifications are subject to change.

### te.com

©2026 TE Connectivity plc. family of companies. All Rights Reserved.

TE Connectivity, TE connectivity (logo) and Every Connection Counts are trademarks owned or licensed by the TE Connectivity plc. family of companies. All other logos, products and/or company names referred to herein might be trademarks of their respective owners.

While TE has made every reasonable effort to ensure the accuracy of the information in this document, TE does not guarantee that it is error-free, nor does TE make any other representation, warranty or guarantee that the information is accurate, correct, reliable or current. TE reserves the right to make any changes to the information contained herein without prior notice. TE Connectivity assumes only those obligations set forth in the terms and conditions for this product and shall in no event be liable for any incidental, indirect, or consequential damages arising out of the sale, resale, use, or misapplication of the product. TE expressly disclaims any implied warranties with respect to the information contained herein, including, but not limited to, implied warranties of merchantability or fitness for a particular purpose. Dimensions, specifications and/or information contained herein are for reference purposes only and are subject to change without notice. Consult TE for the latest dimensions, specifications and/or information. Users of TE Connectivity products must make their own assessment as to whether the respective product is suitable for the respective desired application.

05/26 ED