



	Page
1.1 Cable Scout+	9
1.2 Cable Scout+ Attachments	10
1.3 Technical Information/Packages	11
1.4 Cable Dispensing Tools	14
1.5 Hole Saws & Kits	15-23
1.6 Jigsaw Blades and Hacksaw Blades	24-25
1.7 Hole Cutting and Drills	26
1.8 Personal Safety Equipment	27-29
1.9 VDE Safety Tools	31-33
1.10 Tools	34-36
1.11 Tool Bags and Tool Belts	37-38
1.12 Lubricants and Sealants	39
1.13 Chemicals and Aerosols	41-46
1.14 Din Rail	47-48
1.15 Cable Glands	49-52
1.16 Fixings	53
1.17 HelaCon Plus	55-59
1.18 HelaCon Lux	60-61
1.19 HelaCon Kits	62
1.20 Connector Box	63
1.21 Terminal Strips	64
1.22 Terminals / Crimp Tools	65-68
1.23 Terminal Blocks & Accessories	69-73



Cable Scout⁺

Cable Scout⁺ has been specifically designed to be a time saving device to assist with many types of cable installation applications. Cable Scout⁺ can tackle some of the most difficult tasks users will encounter, routing, pulling and retrieving cables in the fastest and most economical way possible.

Deluxe Set CS-SD:

The most comprehensive set for carrying out larger installations.

Contents:	2 x 4mm x 1000mm (white) 6 x 5mm x 1000mm (red) 2 x 6mm x 1000mm (blue)
Rod Capacity (m):	10
Contents:	150mm white flexi lead, split ring, gender changer, tuff hook, mini eye, domed bullet, flat bullet, beam, single magnet.

Includes a light-weight carry bag with shoulder strap.

Deluxe Set	
Product	Reference
Deluxe Set	CS-SD



Standard Set CS-SB:

Designed to perform standard cable installation:

Contents:	10 x 4mm x 1000mm (white)
Rod Capacity (m):	10
Contents:	150mm white flexi lead, gender changer, tuff hook, mini eye.

Includes a light-weight easy access carry bag.

Standard Set	
Product	Reference
Standard Set	CS-SB



Handy Set CS-SH:

Suitable for tool box storage:

Contents:	1 x 4mm x 400mm (white) 2 x 5mm x 400mm (red) 1 x 6mm x 400mm (blue)
Rod Capacity (m):	1.6
Contents:	400mm white flexi lead, domed bullet, mini hook, mini eye

Includes a light-weight easy access carry bag.

Handy Set	
Product	Reference
Handy Set	CS-SH



Rod Pairs CS-P4, CS-P5, CS-P6, CS-PN:

Type: CS-P4, CS-P5, CS-P6, CS-PN

Contents:	4mm x 1000mm White Rods x 2 5mm x 1000mm Red Rods x 2 6mm x 1000mm Blue Rods x 2 5mm x 1000mm Nylon Rods x 2
------------------	---

Flexibility: Flexible, medium, strong, fully flexible

Rod Pairs	
Product	Reference
Rod Pairs	CS-P4, CS-P5, CS-P6, CS-PN



Attachments:

Whisk

Enables cables to glide over rough and uneven surfaces, and is particularly useful routing cable over ceiling insulation and joists.

Whisk	
Product	Reference
Whisk	CS-AW



Beam

Useful for inspection purposes in dark surroundings, fits onto any of the rod sets. Includes AAA battery.

Beam	
Product	Reference
Beam	CS-AB

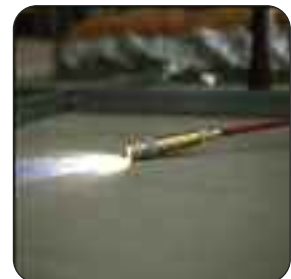

Cable Grips

Provides a quick and secure method of attaching cables to your rod sets. Grips reference CS-AXG0415 contains 3 cable grips suitable for a range of cable diameters from 4mm to 15mm. CS-ACG1630 contains 2 cable grips suitable for a range of cable diameters from 16mm to 30mm.

Cable Grips	
Product	Reference
Cable Grips	CS-ACG0415, CS-ACG1630



Strong Magnet

A helpful tool to lift metal objects up to 2.5kg in weight and can be used in conjunction with the chain to aid location.

Strong Magnet	
Product	Reference
Strong Magnet	CS-AMG2



Attachment Kit

Includes a 150mm long flexi lead, gender changer, mini hook, tuff hook, mini eye, split ring, round bullet, flat bullet, single magnet and chain.

Attachment Kit	
Product	Reference
Attachment Kit	CS-SA



Technical Information

Technical Table		
Colour	Flexibility	OD (mm)
Blue (BU)	Strong	6
Red (RD)	Medium	5
White (WH)	Flexible	4
Semi-transparent white	Fully Flexible	5



Performance Criteria:

The Rods are available in a number of different colours. Each colour signifies the external diameter of the Rod. Difference diameters of Rod have a different flexibility and consequently differing bending radius.

The maximum recommended bending radius for each of the Rods is shown in the diagram on the left.

Rods made of glass reinforced plastic (GRP) are able to pull a cable weight of up to 200kg.

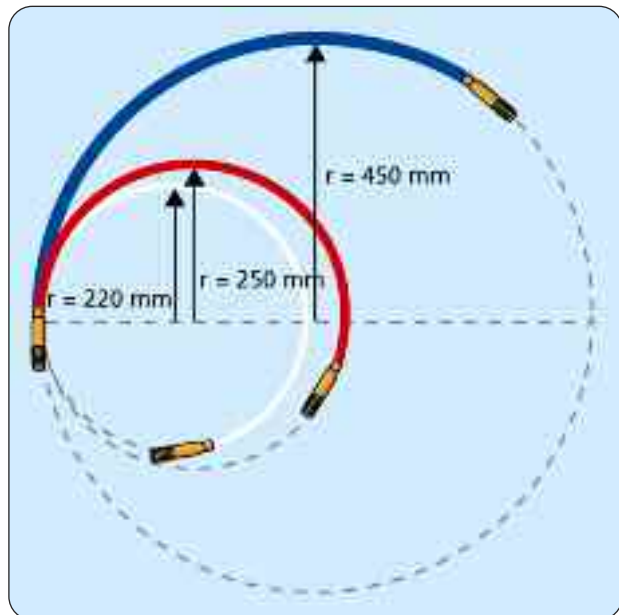

Many merchandising solutions are available!



For more information please contact us
0 1 9 2 2 4 5 8 1 5 1
distribution@hellermanntyton.co.uk



Cable Scout⁺

its all in the bag...



now with more pockets!!
what will you put in yours???

HellermannTyton

HellermannTyton

Cable Scout⁺

its all in the bag...









*New design, more pockets, more space,
more flexibility...*



order now:
01922 458 151
www.hellermannityton.co.uk

HellermannTyton











Welcome to the world of perfect cable management solutions.

To find out more contact us: **01922 458 151** distribution@hellermannityton.co.uk

www.hellermannityton.co.uk

Rack-A-Tiers ®

The Dependable Multi-Purpose Premium Wire Dispensing Tool

With RACK-A-TIERS you'll experience unmatched versatility!

- Ease of transport and storage
- Lightweight
- Durable one piece construction
- Waterproof, easy-clean
- Won't rust or rot
- Won't mark surfaces
- Made of recycled material
- Made in Canada

The ONE TOOL that does it all!

- Wire dispenser
- Pipe vise
- Saw horse
- Work bench
- Wall shelf
- Table

Cable Pulling Stands

- Unmatched ease & speed of set up
- Excellent versatility of use
- Accommodates wide range in cable sizes
- Loads of up to 150Kg (330lbs)
- Has 5* 1 1/4" (44.5mm) holes, 3* carry handles, & 2* V notches to hold larger cable bars
- Easy to store & transport
- Contractor to supply the conduit/bars for the mounting on the Rack-A Tier



Rack-A-Tiers		
Description	Order Code	Quantity
Rack-A-Tier	RT1	1

Starrett

HellermannTyton, aware of the needs of the professional user, presents a range of Starrett hole saws. Starrett bi-metal hole saws are constructed of hardened, heat and abrasion resisting high-speed steel teeth with a tough alloy body and cap in high visibility yellow. This gives them exceptional strength, durability and shatter resistance for user safety. They will cut any wood, metal or plastic in either a handheld drill or drill press. These can be used in a wide variety of applications from production and maintenance to the electrical and building trades.

Starrett Hole Saws			
Boxed Reference	Saw Dia	Arbor	Quantity
SH0096 *FCH0096-E	14MM	A1, A4	1
SH0058 *FCH0058-E	16MM	A1, A4	1
SH1016 *FCH1016-E	17MM	A1, A4	1
SH0034 *FCH0034-E	19MM	A1, A4	1
SH2532 *FCH2532-E	20MM	A1, A4	1
SH1036 *FCH1036-E	21MM	A1, A4	1
SH0078 *FCH0078-E	22MM	A1, A4	1
SH1056 *FCH1056-E	24MM	A1, A4	1
SH0100 *FCH0100-E	25MM	A1, A4	1
SH0116 *FCH0116-E	27MM	A1, A4	1
SH0118 *FCH0118-E	29MM	A1, A4	1
SH0136 *FCH0136-E	30MM	A1, A4	1
SH0114 *FCH0114-E	32MM	A2, A10	1
SH0156 *FCH0156-E	33MM	A2, A10	1
SH0138 *FCH0138-E	35MM	A2, A10	1
SH0176 *FCH0176-E	37MM	A2, A10	1
SH0112 *FCH0112-E	38MM	A2, A10	1
SH0196 *FCH0196-E	40MM	A2, A10	1
SH0158 *FCH0158-E	41MM	A2, A10	1
SH1116 *FCH1116-E	43MM	A2, A10	1
SH0134 *FCH0134-E	44MM	A2, A10	1
SH1136 *FCH1136-E	46MM	A2, A10	1
SH0178 *FCH0178-E	48MM	A2, A10	1
SH0200 *FCH0200-E	51MM	A2, A10	1
SH0216 *FCH0216-E	52MM	A2, A10	1
SH0218 *FCH0218-E	54MM	A2, A10	1
SH56MM *FCH56MM-E	56MM	A2, A10	1
SH0214 *FCH0214-E	57MM	A2, A10	1
SH0256 *FCH0256-E	59MM	A2, A10	1
SH0238 *FCH0238-E	60MM	A2, A10	1
SH0212 *FCH0212-E	64MM	A2, A10	1
SH0296 *FCH0296-E	65MM	A2, A10	1
SH0258 *FCH0258-E	67MM	A2, A10	1
SH68MM *FCH68MM-E	68MM	A2, A10	1
SH0234 *FCH0234-E	70MM	A2, A10	1
SH0278 *FCH0278-E	73MM	A2, A10	1
SH0300 *FCH0300-E	76MM	A2, A10	1
SH0318 *FCH0318-E	79MM	A2, A10	1
SH0314 *FCH0314-E	83MM	A2, A10	1
SH0338 *FCH0338-E	86MM	A2, A10	1
SH0312 *FCH0312-E	89MM	A2, A10	1
SH0358 *FCH0358-E	92MM	A2, A10	1
SH0334 *FCH0334-E	95MM	A2, A10	1
SH0378 *FCH0378-E	98MM	A2, A10	1
SH0400 *FCH0400-E	102MM	A2, A10	1
SH0418 *FCH0418-E	105MM	A2, A10	1
SH0414 *FCH0414-E	108MM	A2, A10	1
SH0438 *FCH0438-E	111MM	A2, A10	1
SH0412 *FCH0412-E	114MM	A2, A10	1
SH0434 *FCH0434-E	121MM	A2, A10	1
SH0500 *FCH0500-E	127MM	A2, A10	1
SH0514 *FCH0514-E	133MM	A2, A10	1

* code to be used from June 2014



Advantages:

- Exceptional strength and durability
- Smooth cut on thinner gauge materials.
- Less tendency to bite or snag on thinner gauge materials.
- Cutting depth 41mm (1 5/8").
- Shatter Resistant

The Hidden Edge Knife

The hidden edge keeps the blade safely tucked away when not in use, yet instantly available by simple releasing the safety lock and squeezing the lever.

- Supplied with 3 blades
- Adjustable cutting depth
- Quick release blade change
- Storage for up to 10 blades.

The Hidden Edge Knife		
Reference	Description	Quantity
SO11	The hidden edge Knife	1





Merchandising Packages

HellermannTyton can offer a range of merchandising options with eye catching displays which significantly increase sales and profits of the Starrett range of products.

- Merchandiser supplied free of charge with stock package
- Attention grabbing signage
- Increase sales of products
- Increase awareness of products stocked
- Take advantage of impulse buying

Call our customer service department for further details on 01922 458151.



Trade Counter Option



Floor Standing Options
2 versions 665mm wide and 1000mm wide

Reference	Description	Quantity
LSO1-CTU	Table Top Merchandiser	1
FSD004	Floor Standing Merchandiser 665mm wide	1
FSD003	Floor Standing Merchandiser 1000mm wide	1



DEBRIS COLLECTOR – HTDB2

No clean up, no drill damage, no debris spread!



Pass the shank of the arbor through the hole at the bottom of the HTDB2 and attach to the drill in the normal way. Always ensure that the Debris Collector spins freely prior to use.



Pass the shank of the arbor through the hole at the bottom of the HTDB2 and attach to the drill in the normal way. Always ensure that the Debris Collector spins freely prior to use.



Drill the hole!



All the dirt and debris from the cut hole is collected inside the Debris Collector!

Debris Collector		
Reference	Description	Quantity
HTDB2	Debris Collector	1

**Works with Starrett
Bi Metal
and Multi Purpose
Hole Saws**

NO CLEAN UP!

No need for time consuming masking of areas prior to drilling or clean up after drilling!

NO DRILL DAMAGE!

No dust or other debris in the drill motor!

NO DEBRIS SPREAD!

No spread of dust in the air

Bi Metal Cordless Smooth Cutting Hole Saw

- Thin wall hole saw for cordless drills
- Each saw supplied complete with arbor, Pilot drill and ejector
- 8 TPI smooth cutting hole saw
- Integral safety stop collar makes this hole saw ideal for use in cutting through electrical panels
- Suitable for cutting thin sheet metal such as Stainless Steel, Mild Steel, Copper, Zinc Plated Steel and Plasterboard
- Cutting depth 13mm
- Range 16mm to 38mm



Bi Metal Hole Saw		
Ref	Saw Dia	Quantity
CSC16	16mm	1
CSC20	20mm	1
CSC22	22mm	1
CSC25	25mm	1
CSC27	27mm	1
CSC29	29mm	1
CSC32	32mm	1
CSC35	35mm	1
CSC38	38mm	1



Kits available see page 22

Arbors

Four standard models are available, each one furnished with a 6.35mm (1/4") high speed steel pilot drills. The set-screw in the body allows for easy replacement of the pilot drill.

A4 type arbors are suitable for use with the AQC14 Quick Change Connector, A1 and A10 type arbors are suitable for use with the AQC38 Quick Change Connector.

Arbors		
Boxed Reference	Description	Quantity
A1	9.5mm Chuck	1
A10	9.5mm Quik-Hitch	1
A2	13.0mm Quik-Hitch	1
A4	6.35mm Round Shank	1
A5	Extension For A2, A17-12 & XA2	
A15	Extension For A1, A10, A17-38, XA1, XA10 & XA17-38	1
A014C	Pilot Drill All Types Except A4	1
A7	Ejector Spring	1
A1-1	For Holesaws 14-30mm - Use with SDS Chuck & Shank	1
A2-1	For Holesaws 32-152mm - Use with SDS Chuck & Shank	1



'Oops' Arbor

The A19 'Oops' arbor is for use in conjunction with either the A1, A2 or A10 hole saw arbors. Replacing the pilot drill, the A19 allows diameters to be enlarged by attaching a saw of the same size to that of the existing hole, thereby acting as a pilot for the larger diameter saw. Minimum hole enlargement is 4.7mm (3/16") between the pilot and the cutting saw diameter.



'Oops Arbor		
Boxed Reference	Description	Quantity
OOPS Arbor (A19)	Fits A1, A2 or A10 type Arbors	1

Hole Saw Kits

A range of Starrett hole saws in a durable, hard wearing carry case.

Starrett Hole Saw Kits			
Reference	Description	Contents	Quantity
KS2000G	General Purpose Kit	22, 29, 35, 44, 51 & 64mm A1 & A10, A7 Ejector Spring	1
KS2000E	Electricians Kit	16, 20, 25, 29, 44, & 51mm A1 & A10, A7 Ejector Spring	1
KS2000DE	Deluxe Electricians Kit	16, 20, 22, 25, 29, 35, 44, 51 64, 68 & 76mm, A1 & A2, A7 Ejector Spring	1
KS2000PE	Plumber & Electricians Kit	16, 20, 22, 29, 35, 38, 40, 44, 51, 57, 65, 68mm, A1 & A2, A7 Ejector Spring	1
KCSC2000G	General Purpose Kit	16, 20, 25, 29, 30, 32, 38 & AQCDH Quick Change Connector	1



ULTI-MATE Rapid Release Arbor System

The **ULTI-MATE** from Starrett offers super fast tool free changes between different diameters of hole saw without adjustment of the drill chuck. Removal of cores from a hole saw after a cut is also much improved by the rapid release of the hole saw from the arbor.



Using the **ULTI-MATE!**

ATTACHING A HOLE SAW

Screw the adapter onto the hole saw and push down **(1)**. Then turn the hole saw and the collar will click on **(2)**.



LOCKING A HOLE SAW

To lock it turn the collar on the arbor so that the arrow on the base of the arbor and the arrow on the collar are not aligned **(1)**.



RELEASING A HOLE SAW

To release it align the arrow on the collar and the arrow on the base of the arbor **(1)** and pull the collar back **(2)**.



Ref No	Desc	Qty
A3	Ulti-Mate Hole Saw Arbor with Pilot Drill (Hole Saw Adapters not included)	1
A3-6	ULTI-MATE hole saw arbor with pilot drill and one of each of the standard holesaw adapters (A3-3 and A3-4)	1
A3-3	Pack of three Ulti-Mate Hole Saw Adapters suitable for Hole Saws 14-30mm / 9/16 - 1.3/16"	1
A3-4	Pack of three Ulti-Mate Hole Saw Adapters suitable for Hole Saws 32-102mm / 1.1/4 - 4"	1
A3-5	Ulti-Mate Hole Saw Adapter, suitable for heavy duty cutting on large diameter saws (102mm/4" and greater)	1
A014M	Replacement Drill for Ulti-Mate Arbor	1
A3-7	Ulti-Mate Hole Saw Arbor with Pilot Drill, 20mm / 25/32" and 25mm / 1" Constant Pitch Hole Saws and Adapters	1
A3-8	Ulti-Mate Hole Saw Arbor with Pilot Drill, 20mm / 25/32" and 25mm / 1" Dual Pitch Hole Saws and Adapters	1

ULTI-MATE
Rapid Release Arbor System

Starrett®



Now in a kit!

The ULTI-MATE from Starrett offers super fast tool free changes between different diameters of hole saw without adjustment of the drill chuck. Removal of cores from a hole saw after a cut is also much improved by the rapid release of the hole saw from the arbour.



Contents of kit	
SH0058 *FCH0058E -	16mm fitted with Ulti-mate Adapter
SH2532 *FCH2532E -	16mm fitted with Ulti-mate Adapter
SH0100 *FCH0100E -	16mm fitted with Ulti-mate Adapter
SH0114 *FCH0114E -	16mm fitted with Ulti-mate Adapter
SH0196 *FCH0196E -	16mm fitted with Ulti-mate Adapter
SH0200 *FCH0200E -	16mm fitted with Ulti-mate Adapter
A3 Ulti Mate arbor with pilot drill.	

* code to be used from June 2014

Using the ULTI-MATE!

ATTACHING A HOLE SAW

Screw the adapter onto the hole saw and push down (1). Then turn the hole saw and the collar will click on (2).



Reference	Description
KS2000E1 (A3)	Hole Saw Kit

LOCKING A HOLE SAW

To lock it turn the collar on the arbor so that the arrow on the base of the arbour and the arrow on the collar are not aligned (1).



RELEASING A HOLE SAW

To release it align the arrow on the collar and the arrow on the base of the arbor (1) and pull the collar back (2).



Exclusive to
HellermannTyton



BI-METAL CORDLESS SMOOTH CUTTING HOLE SAW KIT KCSC2000E1

A handy kit comprising of three bi-metal cordless smooth cutting hole saws.

Kit contents:

1 x CSC20 (20mm)

1 x CSC25 (25mm)

1 x CSC32 (32mm)



- Thin wall hole saw for cordless drills
 - Saw comes complete with arbor, pilot drill and ejector
 - 8 TPI smooth cutting hole saw
 - Integral safety stop collar makes this hole saw ideal for use in cutting through electrical panels
- Suitable for cutting thin sheet metal such as stainless steel, mild steel, copper, zinc plated steel and plasterboard
Cutting depth 13mm



Smooth Cutting Hole Saw Kit		
Reference	Description	Quantity
KCSC2000E1	Smooth Cutting Hole Saw Kit	1

Downlight Hole Saw Kit

Tungsten Carbide Tipped Fast Cut Multi Purpose Hole Saws are perfect for plasterboard, wood, ceramics and anything which is wood based. The new kit contains all the most popular hole saw sizes for cutting downlight apertures.

Kit Contents:

1x35mm	1x73mm
1x40mm	1x76mm
1x44mm	1x83mm
1x51mm	1x86mm
1x60mm	1x92mm
1x65mm	1xA17-38 Arbor
1x70mm	



Down Light Hole Saw Kit		
Reference	Description	Qty
KMPH2000DL	Downlight Kit	1

Tungsten Carbide Tipped Fast Cut Multi Purpose Hole Saws



Starrett Tungsten Carbide Tipped Fast Cut Multi Purpose Hole Saws (MPH Hole Saws) are the perfect tool for users from construction and installation engineers to the DIY enthusiast. Offering very fast cutting times, and outstanding life, the MPH saws will power through wood, MDF, plastics and ceramic wall tiles. For installers our range of kits provide the perfect solution to all your cutting needs.

- Carbide tipped teeth for outstanding cutting performance and product durability
- Smooth cut, with minimal heat build up
- Cutting depth 54mm (2.1/8"). This allows use for cutting through strapping and joists, removing the need for ship auger drill bits.
- Suitable for use in mains and battery powered tools.
- Multiple uses - cutting wood, mdf, plastics, ceramic wall tiles and building bricks
- A range of general purpose and specialist Locksmith's Kit are available, featuring the most popular sizes of saw and appropriate arbors.

Diameter		Cat No	Arbor Ref No
mm	Inch		
20	25/32	MPH2532	1/2
22	7/8	MPH0078	1/2
25	1	MPH0100	1/2
30	1.3/16	MPH0136	1/2
32	1.1/4	MPH0114	3/4/5
38	1.1/2	MPH0112	3/4/5
41	1.5/8	MPH0158	3/4/5
51	2	MPH0200	3/4/5
54	2.1/8	MPH0218	3/4/5
64	2.1/2	MPH0212	3/4/5

Recommended Arbors					
Arbor Ref	Cat No	Fits Hole Saws		Fits Chuck Size	Additional Information
		mm	Inch		
1	A1E or XA1	14-30	9/16-1.3/16	9.5mm/3/8"	Fits AQC 38 Quick Change Connector
2	A4E or XA4C	14-30	9/16-1.3/16	6.5mm/1/4"	Fits AQC 14 Quick Change Connector
3	A17-38E or XA17-38	32-159	1.1/4-6.1/4	9.5mm/3/8"	Locking Arbor, fits AQC38 Quick Change Connector
4	A2E or XA2	32-159	1.1/4-6.1/4	13mm/1/2"	Quick Hitch Arbor

Hole Saw Kits			
Description	Cat No	Hole Saw Sizes	Arbors
General Purpose Kit 1	KM PH2000GP1	19mm, 22mm, 29mm, 35mm, 44mm and 51mm	A1E & A17-38E

NOTE: (1) For hole saws greater than 30mm (1.3/16") dia the Locking Arbor is the recommended arbor as it will provide the best results and maximise the life of the saw, although the A2E and A10E will also be suitable. (2) When cutting ceramics a carbide tipped pilot drill is recommended. Please order XA arbors.

Jig Saw Blades

Starrett offers industrial quality high speed steel edge bi-metal blades.

These blades have a high speed steel cutting edge welded to a tough, flexible back. This combination provides long life and makes them virtually unbreakable. These Jigsaw blades have the pitch printed on the shank end so that it will not easily wear off - no more guessing the pitch of a used blade.

Features & Benefits

- One shank fits all jig saw machines
- Only 17 blades to meet all cutting requirements
- 170% greater resistance to tooth breakage and fracture
- 25% more tool life
- Smoother, faster, straighter cuts
- Shatterproof design, unbreakable during normal use
- Lower cost per cut
- Merchandisable



For use on	Reference	Cutting Length	Width	No. Of Blades Per Pack
Wood	BU36T-5	75mm	7.5mm	5
Wood	BU36-5	75mm	7.5mm	5
Wood	BU46-5	100mm	9.5mm	5
Wood	BU56-5	125mm	9.5mm	5
Wood	BU38-5	75mm	7.5mm	5
Wood	BU310T-5	75mm	7.5mm	5
Wood	BU310DT-5	75mm	7.5mm	5
Multi purpose	BU41014-5	100mm	9.5mm	5
Multi purpose	BU214-5	50mm	7.5mm	5
Multi purpose	BU214S-5	50mm	4.5mm	5
Multi purpose	BU218-5	50mm	7.5mm	5
Multi purpose	BU418-5	100mm	9.5mm	5
Abrasive Materials	BU230X-5	50mm	7.5mm	5
Metal	BU224-5	50mm	7.5mm	5
Metal	BU224S-5	50mm	4.5mm	5
Metal	BU424-5	100mm	9.5mm	5
Metal	BU232-5	50mm	7.5mm	5

STARRETT JIGSAW BLADE WALLET

A 14 blade wallet of assortment Starrett jigsaw blades for cutting wood and wood based materials, plastics, acrylic and metal.

- Mixture of fine finish blades and some blades for high speed cutting
- Wallet includes dual cut, the Starrett patented blade for a top quality finish on both sides of wood and coated boards
- Starrett unified shank fits virtually all jigsaw blades.

Smooth Cutting Hole Saw Kit		
Reference	Description	Quantity
BU6	14 Blade Jigsaw Wallet	1



Hacksaw Frames

A range of heavy duty hacksaw frames and Junior Hacksaw frames.

Hacksaw Frames		
Reference	Description	Quantity
140G	Starrett Heavy Duty Tension Hacksaw Frame	1

- High tension frame
- Suitable for 300mm/12" blade
- Supplied with one bi-metal Safe-flex Frame

Hacksaw Frames		
Reference	Description	Quantity
145	Starrett Heavy Duty Hacksaw Frame	1

- Professional quality high tension hacksaw frame providing an easy to use adjustment handle, comfortable rigger handle and an ergonomic grip.
- 6 turns of the adjustment handle will tension the blade up to 2000kgs/cm sq.
- High tension keeps the blade from twisting and binding even in the most aggressive applications.
- Mounting pins keep the blade secure even when the tension is released.
- Supplied complete with one Bi-metal Unique Safe-flex blade.



Ref - 140



Ref - 145

Hacksaw Blades

A range of bi-metal hacksaw blades, 24 and 32 TPI (teeth per inch).

Hacksaw Blades		
Ref	Description	Quantity
BS1224	Starrett Blue Stripe – High Speed Steel 24PTI	100
BS1232	Starrett Blue Stripe – High Speed Steel 32TPI	100
GS1224	Starrett Grey Flex 24 TPI	100
GS1232	Starrett Grey Flex 32 TPI	100
KBS1218-10	Starrett 300 x 13 x .65mm hacksaw blades 18 TPI	10
KBS1224-10	Starrett 300 x 13 x .65mm hacksaw blades 24 TPI	10
KBS1232-10	Starrett 300 x 13 x .65mm hacksaw blades 32 TPI	10
DJH632	Disston Junior Hacksaw Blades	10



Hole Cutters

All cutting tools are ground using cubic Crystalline Boron Nitride (CBN). This gives a perfect cutting edge that lasts considerably longer and is more precise than other forms of grinding. All products are CBN ground from fully hardened material making further heat treatment which can distort the cutting edges and precision of the tool unnecessary.

Step Drills

The CBN ground and spiral flutes ensure quiet operation and high performance. The tapered, chamfered end of the cone makes it easier to withdraw the tool from the material.

Non slip point; needs no centre punch

- Enlarges existing holes
- Round shank
- Each step laser marked with hole size
- Can be used on non ferrous metal, special steel, thermoplastics and duoplastics



Step Drills		
Reference	Size	Cut out
101050-5	0/5	4-12mm - 5 steps
101051	1	4-20mm - 9 steps
101052	2	4-30mm - 14 steps
101095	11	6-25mm - 9 steps

Tube and Sheet Drills

The CBN ground and spiral flutes ensure quiet operation and high performance. The tapered, chamfered end of the cone makes it easier to withdraw the tool from the material.

Non slip point; needs no centre punch

- Enlarges existing holes
- Round shank
- Can be used on non ferrous metal, special steel, thermoplastics and duoplastics



Tube Sheet Drills		
Reference	Size	Cut out
101001	1	3-14mm
101002	2	5-20mm
101022	9	5-22.5mm
101003	3	16-30.5mm
101004	4	24-40mm
101005	5	36-50mm

Switch and Socket Box Rethreaders

HSS taps fitted with moulded handle. Designed for cleaning the threads in fixings holes of sockets or switch boxes with malformed threads or are blocked with plaster or cement.

Switch & Socket Rethreaders		
Reference	Size	Cut out
230350	3.5mm	Rethreader (No.1 selling size used)
230040	4.0mm	Rethreader



Guide and Dies

Guide & Dies	
Reference	Description
180/0020	20mm Die
180/0030	25mm Die
180/0050	20mm Guide
180/0060	25mm Guide
180/120	20 & 25mm Guide and Die Set

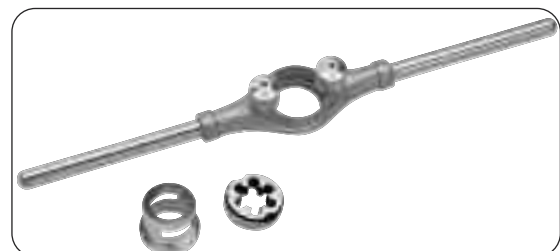

Eye Protection

Plano Eyewear

HellermannTyton, aware of the needs of the professional user, presents a new range of Plano security eyewear that offers comfort and a modern design in the most complete respect of European EN166 Standards specification.

G13

- Extremely sporting and lightweight frameless glasses
- Wraparound lenses offer total protection and unrestricted side view
- Polycarbonate, antiscratch and ultraviolet protection
- Cannot be used for welding

Recommended for

- Every mechanics processing: grinding, drilling and cutting
- Building

G13			
Reference	Frame Colour	Lens Colour	Pack Qty
PLG13	Silver	Transparent	1



G14

- Extremely sporting and lightweight frameless glasses
- Wraparound lenses offer total protection and unrestricted side view
- Polycarbonate, sun and ultraviolet protection
- Cannot be used for welding

Recommended for

- Every mechanics processing: grinding, drilling and cutting
- Building
- Outdoor applications where sunlight and glare cause eyestrain and fatigue

G14			
Reference	Frame Colour	Lens Colour	Pack Qty
PLG14	Blue	Blue mirror	1



G15

- Extremely sporting and lightweight frameless glasses
- Wraparound lenses offer total protection and unrestricted side view
- Polycarbonate, antiscratch, ultraviolet protection and high visibility
- Cannot be used for welding

Recommended for

- Every mechanics processing: grinding, drilling and cutting
- Building
- Low visibility situations

G15			
Reference	Frame Colour	Lens Colour	Pack Qty
PLG15	Gold	Yellow	1



G33

- Anti-scratch and give UV protection.
- Wraparound polycarbonate lenses
- Lightweight frames
- Anti-fog/mist
- Removable ventilation strip designed to prevent misting on the inside and also absorbs perspiration.
- Rubber nose grip provides extra comfort & reduces slipping when the head is lowered.
- Come with an easily attachable lanyard



G33			
Reference	Frame Colour	Lens Colour	Pack Qty
PLG33	Blue	Clear	1

G34

- Sun protective (protect from both UVA & UVB rays) & mirrored finish
- Wraparound polycarbonate lenses
- Lightweight frames
- Anti-fog/mist
- Removable ventilation strip designed to prevent misting on the inside and also absorbs perspiration.
- Rubber nose grip provides extra comfort & reduces slipping when the head is lowered.
- Come with an easily attachable lanyard



G34			
Reference	Frame Colour	Lens Colour	Pack Qty
PLG34	Grey	Silver	1

PL528

- Glasses case to protect all safety glasses featured



Glasses Case	
Reference	Description
PL528TX-3	Glasses Case

Head Torch

- Energy saving, high power long life time ultra bright 1W LED bulb
- ABS/Aluminium alloy body making it light weight 77gm inc. batteries
- 3 function settings
- Uses 3 AAA batteries (included)
- Fully adjustable head strap
- Pivoting lamp
- Bulb life 50,000 hours
- Blister packed

Head Torch		
Reference	Description	Pack Qty
HT105	1W LED Head Torch	1



Knee Protection

Nailers Protective Knee Pads

- New generation of effective knee pad joint protectors
- Comfortable, retain shape better, last longer and absorb shock effectively
- Quick fix and release adjustable straps - for all day comfort
- Fully certified - EN1621/1 - abrasion and impact tested

Protective Knee Pads		
Reference	Size	Qty
60200-G1	Gel swivel knee protector	1



CS
CONNECTIVITY
Solutions

A HUGE Range of Connectivity Solutions for you...

Ranging from Domestic to Industrial Installations.

For more information call our sales team on - **01922 458151**
Alternatively email us at - distribution@hellermannityton.co.uk

HellermannTyton
www.hellermannityton.co.uk

HellermannTyton

Welcome to the world of perfect cable management solutions.

To find out more contact us: **01922 458 151** distribution@hellermannityton.co.uk

www.hellermannityton.co.uk

NWS High Quality VDE Tested Electricians Safety Pliers/Side Cutters

NWS safety pliers are designed to protect personnel working on or around live equipment up to 1000AC and 1500DC. Made in Germany NWS tools are manufactured from top quality raw materials and rigorously tested to ensure compliance with the latest international standards.

NWS "Soft-Gripp"
handle *patented*

Anti-reflective finish

Optimised slip guards
according to EN 60900

Coloured grip marking for
indicating the minimum
safety distance

NWS 2-component-technology
with soft inlay

**5 YEAR
GUARANTEE**

Impact protection by safety cushion *patented*

Signal-colour: red-yellow

Features & Benefits

- Superior design quality pliers
- Patented bi-component red/yellow handles
- Ergonomic design improves handling
- Soft grip inlay indicates safety distance from working head
- Impact resistant safety cushion - protects handles when dropped
- Optimised grip guards in accordance with EN60900
- Optimised grip guards in accordance with EN60900
- Hot drop-forged from special alloy tool steel to NWS specification
- Matt chrome finish for maximum corrosion protection
- Precision cutting edges induction hardened, better cutting, longer life
- Joint and rivet machined and hardened for smooth operation and long life



VDE Safety Tools

6-in-1 VDE Cutter

- Shear M3.5 pattress screws
- Precision cutting edges
- Strip 1.5mm cable
- Strip 2.5mm cable
- Bend wire
- Crimp terminals and end sleeves
- Individually tested to 10,000V

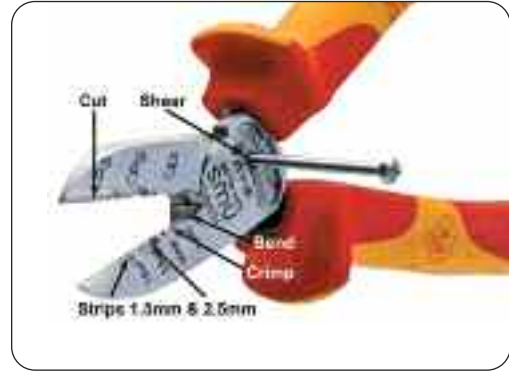

6-in-1 VDE Cutter		
Reference	Description	Qty
N1351-49-VDE-190C	6-in-1 VDE Cutter	1

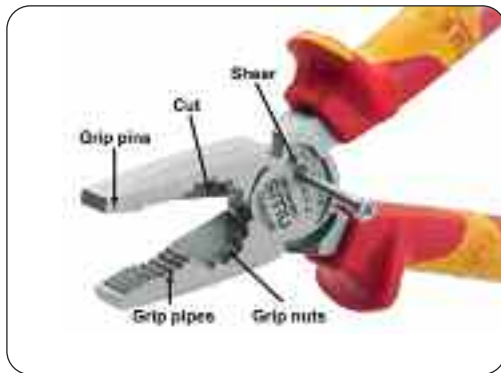

5-in-1 CombiMax Pliers

- Shear M3.5 pattress screws
- Precision cutting edges
- Grip nuts and bolts
- Grip flats and pipes
- Grip nails and pins
- Individually tested to 10,000V

5-in-1 CombiMax Pliers		
Reference	Description	Qty
N1093-49-VDE-180C	5-in-1 VDE CombiMax Pliers	1

2-in-1 VDE Side Cutters

- Shear M3.5 pattress screws
- Induction hardened precision cutting edges
- Improved leverage for better power transmission
- Individually tested to 10,000V

2-in-1 VDE Side Cutters		
Reference	Description	Qty
N1343-49-VDE-160C	2-in-1 VDE Cutter	1

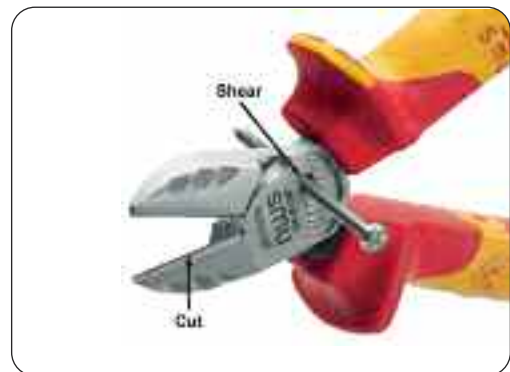

VDE Pliers and Cutters

Combination Pliers		
Reference	Size	Qty
N111-49-VDE-180C	180mm	1
N111-49-VDE-205C	205mm	1

Side Cutters		
Reference	Size	Qty
N134-49-VDE-160C	160mm	1
N134-49-VDE-180C	180mm	1

Heavy Duty Side Cutter		
Reference	Size	Qty
N137-49-VDE-200C	200mm	1

Long Nose Pliers		
Reference	Size	Qty
N140-49-VDE-170C	170mm	1
N140-49-VDE-205C	205mm	1

Wire Stripper		
Reference	Size	Qty
N145-49-VDE-160C	160mm	1

Cable Cutters		
Reference	Size	Qty
N043-49-VDE-160C	160mm	1
N043-49-VDE-210C	210mm	1

Waterpump Plier		
Reference	Size	Qty
N165-49-VDE-240C	240mm	1



VDE ErgoCombi & ErgoMulti Pliers Bi-Component Soft-grip handle

VDE ErgoCombi & ErgoMulti Pliers Bi-Component Soft-grip handle		
Reference	Size	Qty
N509609	7.3/4"/200mm VDE Ergo Combi pliers cuts 2.5mm hard wire – 13mm cable	1
N540626	7.3/4"/200mm VDE Ergo Multi pliers strips 1.5mm cable – 2.5mm cable	1



Nylon Fish Tape

Fish Tape		
Reference	Description	Quantity
DTN10	NYLON 10M	1
DTN20	NYLON 20M	1
DTN30	NYLON 30M	1

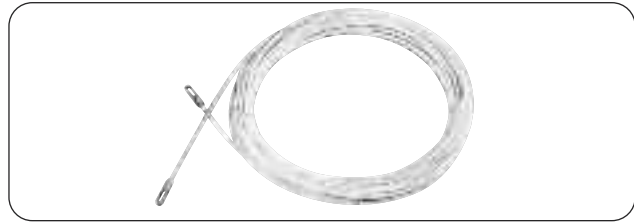

Pro Grabit – Damaged Screw & Bolt Remover

- Removes free spinning screws
- Winslow tip for self centring.
- Double ended 2 piece set.
- removes screw from wood, metal or plastic.
- Screw sizes no6-14.
- Bolt sizes M4-8

Prograbit		
Reference	Description	Qty
PROGRAB	Pro Grabit	1



Yellow Handled Cable Cutters



HTWC200
Cutter for Hardened Steel Stranded Cable

- Cuts hardened steel cable such as catenary wire up to 6mm diameter
- Provides very clean cut without splaying cable strands

Partref	Description
HTWC200	Cable Cutter



HTCA26F
Cable Cutter Suitable for Twin & Earth Cable

- Provides very clean cut of Twin and Earth Cable as well as single cables

Partref	Description
HTCA26F	Cable Cutter



HTCA450-AL
Cable Cutter

- Suitable for cutting Steel Wire Armour Cable up to 17mm diameter or cable of cross sectional area 227mm²
- Will also cut copper and Aluminium cable.

Partref	Description
HTCA450-AL	Cable Cutter

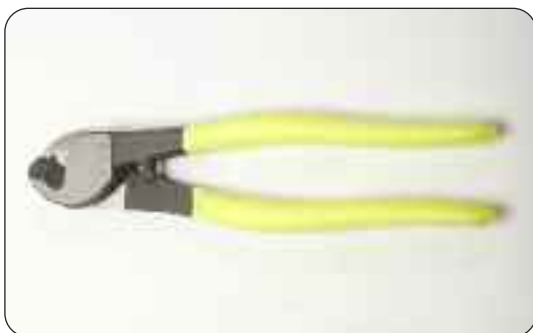

TTC8 & TTC10

- TTC8 - Cable cutting up to 35mm²
- TTC10 – Cable cutting up to 50mm²

Partref	Description
TTC8	Cable Cutters cuts up to 35mm ²
TTC10	Cable Cutters cuts up to 50mm ²



HT63915

- Cutting tool for removal of cable ties without damaging the cable.
- Jaw width 20mm, length 150mm

Partref	Description
HT63915	Cable Tie Cutter

Drill Bit Sets

- Selection of drill bit sets to meet the electricians requirements
- Drill bits to European standards
- Packed in re-usable cases

Drill Bit Sets		
Reference	Description	Qty
205200	170 piece rolled twist drill set. Metal carry case 10 pieces of each 1-8mm, 5 pieces of each 8.5-19mm in increments of 0.5mm	1
D16165	16mm 4 flute drill	1
D120165	20mm 4 flute drill	1
D22165	22mm 4 flute drill	1
D25165	25mm 4 flute drill	1
D32165	32mm 4 flute drill	1
D00165	5 piece set (all above sizes)	1
RU205202	Ruko 13 pce twist drill set	1
A205210	Ruko 19 pce twist drill set	1



Quick Change Adaptor

- Fits 1/4" and 3/8" power tool accessories without power groove
- Time saving – no need to change adaptors
- Quick change – push in shank and pull back collar to release
- Safety lock – secures shank in place
- Ideal for arbors, drill bits, hex screwdriver bits, flat bits and auger bits

Quick Change Adapter		
Reference	Description	Qty
D6567	Quick change Universal Adaptor 10mm (3/8") hexagonal shank	1



Plano Technic Line

- Latest ideas from Plano USA
- New concept in soft storage and work wear
- Smart colour co-ordinated red & grey
- Practical way to store tools
- Easily wiped clean
- Light weight but very durable
- Tools not included

Plano Toolbelts - Matt Black Collection

- Highly water resistant - water repellent, functional toolbelts
- Light weight and padded
- Quick release buckle
- Extremely durable - easily wiped clean
- Waist size 90-120cm
- Tools not included

Plano Toolbelts	
Reference	Size
PL52170	23 pocket belt - 2 x pouches, tape holder (up to 8m), hammer loop
PL52180	15 pocket belt - 1 x pouch, tape holder, cordless drill holster

* Tools not included



Plano Electricians Tool Case

- Pro-bag workstation
- Fit for electronic tools
- Opening on both sides
- Big outer pocket for documents

Plano Electricians Tool Case	
Reference	Description
PL552TX	Electricians Tool Case

* Tools not included



Plano Padded Tool Briefcase

- Large front pocket designed to hold laptop/files/documents, this also features 9 internal pockets and is fastened with 2 clips.
- The rear pocket is padded and ideal for holding tools, features and various sized elasticated tool holders.
- Complete with carry handle and shoulder strap.

Plano Padded Tool Briefcase	
Reference	Description
PL559T	Plano padded tool briefcase

* Tools not included



Plano Back Pocket Pouch

- Fits into back pocket
- Keeps contents safe 'n' secure – at all times
- 1 large tool pocket
- 2 small tool pockets
- Clip for tape rolls, gloves and keys
- Made from hard wearing re-inforced 600 x 600 polyester

Plano Back Pocket Pouch		
Reference	Description	Quantity
PL527RS/MB	Back Pocket Pouch	1

*Tools not included



Double Pocket Tool Holster

- 2 pockets for small tools
- 2 elastic holders for pens, terminal screwdrivers etc
- Universal metal clip to fit onto belts and trousers
- Loop for securing to belts
- Compact design provides useful storage
- Made from hard wearing re-inforced 600 x 600 polyester

Plano Double Pocket Tool Holster		
Reference	Description	Quantity
PL524RS/MB	Double Pocket Tool Holster	1

*Tools not included



NEW Formula Fospro PX

- Industrial Strength Protective Lubricant

Fospro is the complete maintenance treatment for protection against corrosion, water displacement, lubrication and light surface rust removal. One simple application – by spray, swab or dip – stops the spread of existing corrosion, gives lasting protection against further attack and removes and repels ambient moisture. Fitted with a 360° Spray System for all angle use, even upside down.

Application

Fospro PX is specifically used for preservation and corrosive inhibition after operation of certain gas turbine engines and as a de-watering and protective fluid.

Fospro PX is ideal for use on all mechanical and electrical equipment being suitable for use on low voltage equipment up to 250V.

As a penetrant, it will quickly free seized nuts, bolts and bearings, whilst the highly effective water displacing properties make the perfect 'damp-start' solution for ignition systems and other electrical equipment.

The protective, lubricating film is non-conductive and remains operational even at severe sub-zero temperatures. It will not affect paints or plastics and is lastingly effective on all metals, including aluminium. Freshly machined surfaces resist 'finger-marking' and will stay clean and bright, even in highly corrosive conditions.

Reference	Description	QTY
Fospro PX	Fospro - Industrial Strength Protective Lubricant	12 x 400ml



HellermannTyton
Delivering
60,000 Solutions to the
Electrical Wholesaler trade..

To find out more contact us:
Tel - 01922 458 151
 Email - distribution@hellermanntyton.co.uk
www.hellermanntyton.co.uk

HellermannTyton

Welcome to the world of perfect cable management solutions.

To find out more contact us: 01922 458 151 distribution@hellermanntyton.co.uk
www.hellermanntyton.co.uk



Electrical Maintenance		
Product Name / Reference	Carton Qty	Features
Contact Cleaner FG 1/400	1 x 400ml	CONTACT CLEANER FG is a highly effective precision cleaning solvent blend which does not contain chlorinated solvents, alcohols or Glycol ethers. Contact Cleaner FG improves the performance and reliability of electrical/electronic equipment in the food industry by preventing contact failures or malfunctions by dissolving and rinsing away contaminants which may hold moisture and cause corrosion or arcing.
Amberclens 1/400	1 x 400ml	AMBERCLENS is a unique anti-static foaming cleaner based on a blend of surfactants, solvents, inhibitors and water. Unrivalled in performance, it quickly and easily removes all types of dirt, grease, stains, soiling and other contamination from hard surfaces and fabrics.
40+ Protective Lube 1/400	1 x 400ml	AMBERSIL 40+ is the complete maintenance treatment for protection against corrosion, water displacement, lubrication and light surface rust removal. One simple application - by spray, swab or dip - stops the spread of existing corrosion, gives lasting protection against further attack and removes and repels ambient moisture.
AGL1 1/400	1 x 400ml	AGL 1 is a multi purpose, greaseless lubricant preventing electrical and electronic malfunction caused by water penetration, humidity, condensation or corrosion. The stable, low surface tension, high capillary action formula provides great penetrating and wetting power.
SV100 Electrical Varnish 1/400	1 x 400ml	Provides a tough, impervious insulating seal - ideal for components subjected to 'difficult' environments and high humidity. It is particularly suitable for improving leakage characteristics of terminal assemblies and also seals electrical leakage paths. It has excellent resistance to transformer oils and moisture with good noise reduction characteristics. Dries rapidly to form a hard red coloured film.
Amberklene FE10 1/400	1 x 400ml	AMBERKLENE FE10 is a fast evaporating solvent blend which contains no CFCs or other chlorinated solvents. It is an ideal alternative to 1,1,1 Trichloroethane.
CCL100 1/400	1 x 400ml	CCL 100 is a fast drying cleaner for all electrical and electronic components. Ideal for all types of contacts and switches where a light residue of lubrication is required after cleaning. CCL has the following benefits: · Clear, low odour, fast evaporating cleaner, Speedily cleans grease and dirt from metal electrical and electronic components. Low toxicity, Can be used on most plastics, Directional nozzle with separate extension tube.
NF Precision Cleaner 1/400	1 x 400ml	A unique non-flammable precision cleaner for electrical and electronic equipment. Chlorinated hydrocarbons (1,1,1-trichloroethane), chlorofluorocarbons (CFC's) and hydrochlorofluorocarbons (HCFC's) are extremely effective solvents.
IPA 1/400	1 x 400ml	IPA is an internationally approved general purpose, cost effective electronic cleaning solvent. Ideal for cleaning, degreasing and defluxing delicate electronic assemblies. IPA has many advantages including Forming an azeotrope with water to assist removal of moisture, Leaves no residue and is a highly versatile cleaning solvent.
Air Duster 1/400	1 x 400ml	AIR DUSTER is a liquified gas which provides a dry, powerful blast for easy removal of dust and other loose contamination. This product has been formulated without the use of any CFCs or HCFCs.
Anti-Static Spray 1/400	1 x 400ml	ANTI-STATIC SPRAY is a specialist formulation for the temporary reduction of electrostatic charges generated by friction and atmospheric conditions. Anti-Static Spray reduces airborne dust accumulation and is safe to use on most substrates. Particularly useful in the textile and paper making industries or for use in dust laden atmospheres.
AMS4 Silicone Grease 1/400	1 x 400ml	AMS4 SILICONE GREASE provides a smooth, non-melting coating with a broad spectrum of applications. Broad operating temperature range (-50°C to + 200°C), Heat resistant (up to 200°C), Insulates, lubricates, seals, preserves and waterproofs.
Greasil 400	1 x 100ml	High quality, pure silicone grease which is water repellent and non-melting. As an anti-tracking, anti-arcing coating, it will protect electrical systems.

Application	Type
Safe to use on all plastic and rubber surfaces, the rapid evaporation of Contact Cleaner FG ensures that no residues are left on the treated equipment.	Cleaner / Degreaser
Safe to use on all plastic and rubber surfaces, the rapid evaporation of Contact Cleaner FG ensures that no residues are left on the treated equipment.	Cleaner / Degreaser
Ambersil 40+ is ideal for use on all mechanical and electrical equipment. As a penetrant, it will quickly free seized nuts, bolts and bearings, whilst the highly effective water displacing properties make 40+ the perfect 'damp-start' solution for ignition systems and other electrical equipment.	Dewatering Lubricant
Helps to protect, lubricate and restore: Electrical connectors, Motors, Relays, Communication, Assemblies, Generators, Electronics, Circuit breakers, Controls, Alarm systems, Transformers, Instruments, Starters, Switch gears	Greaseless Lubricant
Protecting circuit boards, transformers and other coils, Protecting repaired or reworked jobs, Insulating against humidity and other 'difficult' environments, Improving leakage characteristics of terminal assemblies, Noise reduction in small transformers, Moisture protection, Finishing varnish to stop tracking, Tropicalisation on all types of electrical equipment.	Anti Corrosion / Anti Tracking
A highly effective degreasing agent for all hydrocarbon soiling, including oil, grease, tar and bitumen. For use in numerous industries including; where a fast and effective cleaning solvent is required. Efficiently cleans plastics, ferrous and non-ferrous metals, evaporating quickly to leave a clean, dry surface. Also recommended for spot removal in the textiles and associated industries.	Degreaser
CCL100 is typically used within the following areas: Automotive, Mechanical engineering, Workshops, Dock yards, Agricultural machinery, General maintenance	Contact Cleaner / Lubricant
NF Precision Clean is the first alternative on the market that meets the highest performance characteristics: Chlorinated Hydrocarbon Free, CFC and HCFC Free, Solvent Based, Non-flammable Blend, Fast Evaporation Rate.	Non Flammable Contact Cleaner
IPA is a universally recognised electronic cleaning solvent which conforms to BS 1595, ASTM D770 and DIN 53245.	Cleaner / Degreaser
Suitable for instant cleaning of inaccessible areas or where the use of solvents is not desirable. Can be used safely and efficiently on: Photocopiers, Fax Machines, Typewriters, Computers, Microscopes, Oscilloscopes, Cameras, Lenses, Watches, Precision Instruments & Laboratory Equipment	Cleaner
Plastic components, Screens and monitors, Paper mills, General static discharge	Static Charge Removal
Electronics and Telecommunicatios, Transport, Aviation, Mechanical Engineering and Production.	Silicone Grease
Food, Automotive, Mechanical engineering, Workshops, Civil engineering, Mining, Iron and steel, Dock yards, Agricultural machinery, Heavy engineering, Offshore	Pure Silicone Grease





General Maintenance		
Product Name / Reference	Carton Qty	Features
Label Remover 1/200	1 x 200ml	LABEL REMOVER is a unique blend of citrus and hydrocarbon oils which quickly releases self-adhesive labels and stickers. It neutralises the adhesive, thereby facilitating clean and easy removal.
Cold Gavanise 1/400	1 x 400ml	Cold Galvanising Spray is a unique combination of zinc powders and resins, formulated to form a high performance zinc-rich coating that actively fights rust and corrosion by its galvanic properties. Ferrous metals are protected by the sacrificial action, even when scratched or damaged. Zinc becomes the anode which is attacked by corrosion and the base metal the cathode. A film of water insoluble zinc oxide is formed, which stops rust and corrosion.
Corrosion Inhibitor 1/400	1 x 400ml	Corrosion Inhibitor is a protective coating that provides long lasting protection against rust and corrosion.
Penetrating Oil 1/400	1 x 400ml	PENETRATING OIL is a high-grade lubricating agent based on a mixture of oils and penetrants in a blend of solvents. It has been formulated to offer quick and easy removal of seized and rusted components.
Copper Anti-seize 1/400	1 x 400ml	COPPER PASTE is a high temperature anti-seize lubricant. A soft, copper-coloured paste, based on micronised copper powder and synergistic anti-oxidant, anti-corrosion and anti-wear additives suspended in a premium grade stable oil. It is an effective anti-seize formulation, preventing metal-to-metal contact, seizing, galling, and fretting corrosion.
Silicone Lubricant 1/500	1 x 500ml	SILICONE LUBRICANT is a general purpose, medium duty silicone lubricant, which exhibits excellent anti-stick and slip properties.
Bright Cold Galvanise - 400ml	1 x 400ml	A single component, zinc-aluminium coating combining corrosion protection properties with the lustre look of recently galvanized parts. Bright Cold Galvanising Spray is a combination of zinc and aluminium powders, resins and additives, formulated to form a flexible protective film with a bright, glossy appearance.
Leak Detector 1/400	1 x 400ml	LEAK DETECTOR is a unique water based formulation. It has been developed, without the use of harmful solvents, silicones or oils, to allow the safe and easy detection of all gas and air leaks.
5005a Silicone Sealant 1/75	1 x 75ml	Ambersil Silicone Adhesive Sealant 5005A is a high modulus, one part acetoxo curing sealant conforming to ISO 11600. In its uncured state, the sealant is a thixotropic paste which can be applied over a wide range of temperatures with no risk of slumping from normal joint widths. The product cures rapidly on exposure to moist air to provide a resilient rubber seal capable of repeated extension and compression during service with excellent resistance to aging, shrinkage, cracking and discolouration.
5-minute Epoxy 1/24	1 x 24ml	5-MINUTE EPOXY is a fast setting epoxy in a handy syringe - ideal for keeping in tool box or drawer. Will mend a wide variety of materials including metal, wood, ceramic, porcelain and glass.

Application	Type
Ideal for use on many different non-absorbent surfaces, including: Photocopiers, Fax Machines, Computers, Printers, Typewriters, Platens, Rollers, Cabinets, Shelving, Amusement Machines.	Label Remover
For general use in all situations where clean and degreased metal surfaces need to be protected against corrosion. Suitable for use as a renovation media for repairs to hot dip galvanising, as specified in BS EN ISO 1461:1999.	Galvanising Spray
Corrosion Inhibitor is designed to provide good short to medium term protection of metallic parts and components. Principally designed for indoor use, corrosion inhibitor will also provide a degree of short-term protection to components stored outdoors.	Corrosion Inhibitor
Ideal for freeing nuts, bolts, screws, studs, pins, valves, machine parts, pipe couplings and pulleys. Can also be used for cleaning rusted surfaces of moulds, dies and heavy tools and for softening or removing carbon deposits.	Lubricant
An effective anti-seize lubricant for bolts, nuts, pins etc. Anti-seize to 110°C, Lubricants to 300°C.	Lubricant
Ideal for use where a clean, colourless lubricant is required. Safe to use on wood, glass, fabrics, metals, most plastics, rubbers and hard surfaces. WRAS approved for use in water industry.	Lubricant
Bright, glossy coating for newly galvanised parts.	Anti Corrosion
Highlights all leaks even under low pressure and proves invaluable in the gas, plumbing, heating, automotive, offshore, engineering and welding industries. Ideal for QC tests, maintenance and safety checks meets DIN 30657 and BS EN ISO 14291:2004.	Leak Detector
Ambersil Silicone Adhesive Sealant 5005A offers good adhesion to various non-porous substrates such as glass, glazed ceramic tiles and Aluminium and is therefore recommended for producing formed-in-place gaskets, draught proofing of windows and doors, on-site and factory-channel glazing of flat or profiled glass, patent glazing, curtain wall sealing and for ceramic and plastic joints in sanitary ware, laboratories and hospitals where ease of cleaning and a high standard of hygiene are essential.	Silicone Sealant
Rapid, small scale repairs, Filling small holes and cracks, Repairing worn parts, including shafts, housings, keyways and flanges.	Adhesive





Cutting Compounds

Product Name / Reference	Carton Qty	Features
Tufcut Compound 1/500 Tufcut Spray 1/400	500g 1 x 400ml	The TUF CUT range is comprised of specialist metal cutting lubricants based on a mixture of extreme pressure additives and anti-oxidants. They have been formulated as instant, ready to use metal machining lubricants with high film-strength and resistance to extreme pressures.



Wipes

Product Name / Reference	Carton Qty	Features
Toughwipes 100's Tub	100	Tough wipes are impregnated with an effective cleaning and conditioning solution designed to be gentle on hands but tough on contamination, therefore Ambersil Tough Wipes can assist in the prevention of skin disorders such as occupational dermatitis. Hands are clean and dry in one application, all without the use of water.
Toughwipes 30's Pouch	30	



Electrical Maintenance

Product Name / Reference	Carton Qty	Features
Lec-Klene 1/400 Lec-Klene 1/5 Lec-Klene 1/25	1 x 400ml 1 x 5 ltr 1 x 25 ltr	LEC-KLENE is a highly refined, low aromatic solvent cleaner, which meets DEF STAN 68-148 issue 2, for the safe and effective cleaning of Electrical and Aerospace equipment. The high flash point and low aromatic content enable it to be safely used in confined areas where fire or health risks are to be minimised.

Application	Type
TUFCUT FOAM is a foaming lubricant specifically formulated to enable cutting applications to be performed on vertical surfaces without excessive loss of lubricant from the work piece. Tufcut Foam can also be used where close tolerance machining is to take place as the foam allows a longer contact time, and increased lubricant Cutting Compound	Metal Cutting



Application	Type
Effective on a wide range of soiling types - grease, oil, petrochemicals, paints, adhesives, tar, bitumen, resins and silicone sealants. Contains bactericide effect against Leptosira (Wells Disease).	Hand Wipes



Application	Type
LEC-KLENE is ideal for removing oils, greases, waxes, tar, bitumen, brake block dust, carbon and other general soiling. It has no detrimental effect on painted surfaces, ferrous and non-ferrous metals, composite materials, rubbers and plastics. It totally evaporates to leave surfaces clean and dry, ready for any post cleaning treatments.	Cleaner / Degreaser



DIN Rail

A range of Top Hat and G-Type rail, zinc coated, plain or slotted.

Available in 1 or 2 metre length.

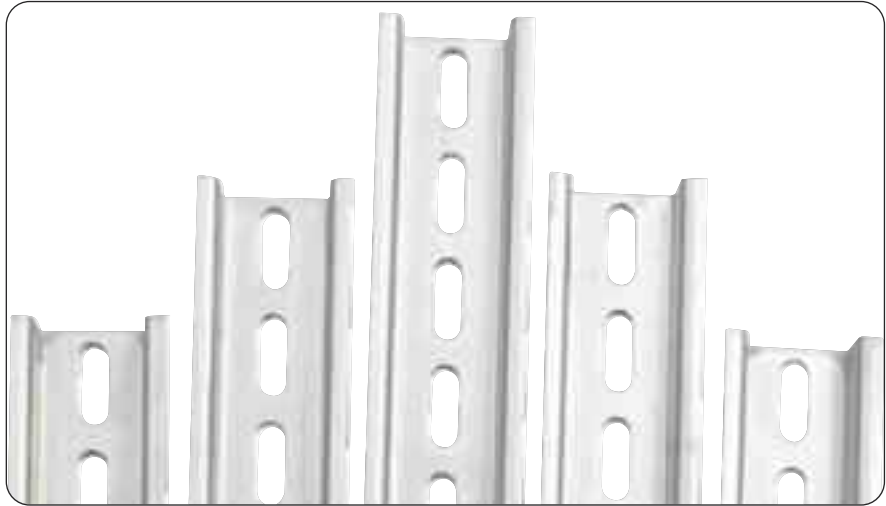

DIN Rail						
Reference	Description	Type	Rail Depth	Rail Width	Rail Length	Pack Quantity
TS15 TS15/F	Mini Top Hat	Standard Slotted	5.5 x 10.5	15mm 15mm	2m 2m	20 x 2 20 x 2
TS32 TS32/F	G Type	Standard Slotted		32mm 32mm	2m 2m	20 x 2 20 x 2
TS35 TS35/F TS35/S	Top Hat	Standard Slotted Standard	7.5 x 27 10 x 27	35mm 35mm 35mm	2m 2m 2m	20 x 2 20 x 2 20 x 2
TS35/C TS35/CF	Deep Top Hat	Standard Slotted	15 x 27 15 x 27	35mm 35mm	2m 2m	20 x 2 20 x 2
TS15/F.10	Top Hat	Slotted	5.5 x 10.5	15mm	1m	10 x 1
TS32.10 TS32/F.10	G Type G Type	Standard Standard		32mm 32mm	1m 1m	10 x 1 10 x 1
TS35.10 TS35/FP.10	Top Hat Top Hat	Standard Slotted	7.5 x 27 7.5 x 27	35mm 35mm	1m 1m	10 x 1 10 x 1
TS350.5 TS35F60.5	Top Hat Top Hat	Standard Slotted	7.5 x 27 7.5 x 27	35mm 35mm	0.5m 0.5m	10 x 1 10 x 1

Galvanised and aluminium available on request.

Mounting Brackets				
Reference	Type	Height	Fixing	Pack Quantity
BK0425	Angled	42mm	M6	2
TS-SM6	Angled	48mm	M6	1
BK0805	Angled	82mm	M6	2
BK0201	Straight	20mm	M6	2
BK0441	Straight	41mm	M6	2
BK0706	Straight	70mm	M6	2
BK0904	Straight	90mm	M6	2
CSK6.3	Screws to Suit		M6	10

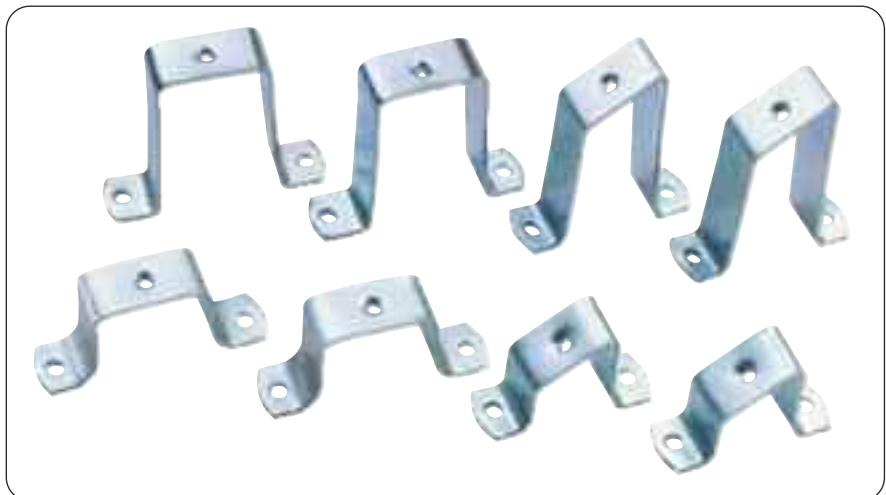

TS 35

Symmetrical 'Top Hat' style steel rail.
Standards: DIN 46277 CENELEC EN 50.022
Pack quantity: 40m (or 10 x 1m)
Weight: 0.35 kg/m Also available in galvanised ref TS 35 G

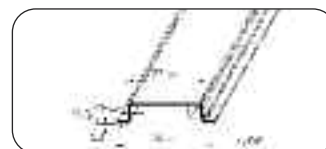

TS 35 F

Slotted version of TS 35.
Standards: DIN 46277 CENELEC EN 50.022
Pack quantity: 40m (or 10 x 1m)
Weight: 0.30 kg/m

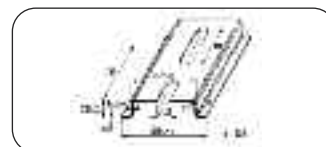

TS 35 C

15mm deep version of TS 35.
Standards: CENELEC EN 50.022
Pack quantity: 40m
Weight: 0.67 kg/m

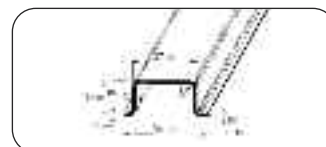

TS 35 CF

Slotted version of TS 35 C.
Standards: CENELEC EN 50.022
Pack quantity: 40m
Weight: 0.615 kg/m

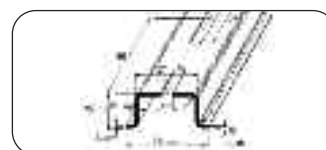

TS 35 S

10mm deep version of Type TS 35.
Standards: DIN 46277 CENELEC EN 50.022
Pack quantity: 40m
Weight: 0.39 kg/m



TS 15

Plain symmetrical rail for terminal block mounting.
Standards: DIN 46277
Pack quantity: 40m
Weight: 0.165 kg/m

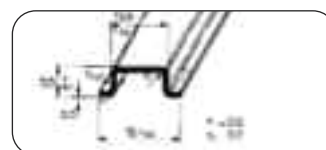

TS 15 F

Slotted version of TS 15.
Standards: DIN 46277
Pack quantity: 40m
Weight: 0.14 kg/m

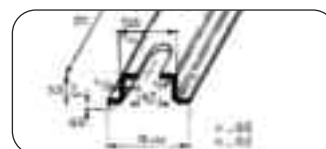

TS 32

Plain assymmetric steel rail punched for drilling.
Standards: DIN 46277 CENELEC EN 50.035
Pack quantity: 40m (or 10 x 1m)
Weight: 0.73 kg/m Also available in galvanised ref TS 32 G

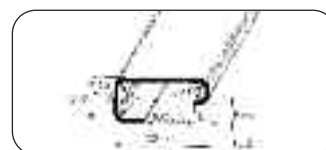

TS 32 F

Slotted version of TS 32.
Standards: DIN 46277 CENELEC EN 50.035
Pack quantity: 40m (or 10 x 1m)
Weight: 0.69 kg/m

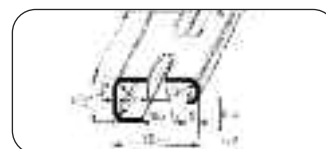

BRASS CABLE GLANDS

Gland Selection Chart For PVC SWA PVC Cables

Cable Cond. Size		Number of Cores													
Area mm ²	Neutral	1	2	3	3½	4	5	7	10	12	19	27	37	48	
1.5	-	-	20S	20S	-	20S	20S	20S	20	20	25	25	32	32	
2.5	-	-	20S	20S	-	20S	20S	20	25	25	25	32	32	40	
4	-	-	20S	20S	-	20	20	25	25	25	32	40	40	50	
6	-	-	20S	20	-	20									
10	-	-	25	25	-	25									
16	-	-	25	25	-	25									
25	16	-	25	25	32	32									
35	16	-	25	32	32	32									
50	25	25	32	32	32	40									
70	35	25	32	40	40	40									
95	50	25	40	40	50	50									
120	70	25	40	50	50	50									
150	70	32	40	50	50	50									
185	95	32	50	50	63	63									
240	120	40	50	63	63	63									
300	150	40	63	63	75	75									
300	185	-	-	-	75	-									
400	185	50	63	75	75	75									
500	-	50													
630	-	50													
800	-	63													
1000	-	63													

Glands manufactured as per
BS 6121 PT1: 1989
 For use with PVC SWA PVC 600/1000V Cables

This selection chart is given for guidance only.
 Actual cable dimension must be considered
 before making final selection.

◇ GLAND KIT

Type BW Indoor Gland

- For use with all types of SWA cables to BS6346
- For use indoors in dry locations
- Simple two part design with low resistance armour locking and no sealing



Type BW Indoor Gland

Reference	Description	Quantity
BW20S	20mm Small	2
BW20	20mm Standard	2
BW25	25mm Standard	2
BW32	32mm Standard	2
BW40	40mm Standard	1
BW50	50mm Standard	1
BW63	63mm Standard	1
BW75	75mm Standard	1

Type CW Industrial Gland

- For use with all types of SWA cables to BS6346
- For use indoors and outdoors whenever it is required to provide a sealing on the cable outer sheath
- CW glands are weatherproof and can be used in corrosive conditions when protected with a shroud
- Positive armour locking, effective earth continuity, increased mechanical strength



Type CW Industrial Gland

Reference	Description	Quantity
CW20S	20mm Small	2
CW20	20mm Standard	2
CW25	25mm Standard	2
CW32	32mm Standard	2
CW40	40mm Standard	1
CW50	50mm Standard	1
CW63	63mm Standard	1
CW75	75mm Standard	1

Type BW Indoor Gland – LSF

- BW LSF Gland for use on LSF cables and applications.
- For use with all types of BW cables
- For use in indoors in dry locations
- Simple two part design with low resistance armour locking and no sealing
- BW Gland LSF compliant as per BS 6724: 1990



Type BW Indoor Gland LSF		
Reference	Description	Qty
LSFBW20S	20mm Small LSF	2
LSFBW20	20mm Standard LSF	2
LSFBW25	25mm Standard LSF	2
LSFBW32	32mm Standard LSF	2
LSFBW40	40mm Standard LSF	1
LSFBW50	50mm Standard LSF	1
LSFBW63	63mm Standard LSF	1
LSFBW75	75mm Standard LSF	1

Type CW Industrial Gland – LSF

- CWLSF Gland for use with LSF cables
- For use indoors and outdoors whenever it is required to provide a sealing on the cable outer sheath
- CWLSF glands are weatherproof and can be used in corrosive conditions when protected with a shroud
- Positive armour locking, effective earth continuity, increased mechanical strength
- CWLSF gland is compliant as per BS 6724: 1990



Type CW Industrial Gland LSF		
Reference	Description	Qty
LSFCW20S	20mm Small LSF	2
LSFCW20	20mm Standard LSF	2
LSFCW25	25mm Standard LSF	2
LSFCW32	32mm Standard LSF	2
LSFCW40	40mm Standard LSF	1
LSFCW50	50mm Standard LSF	1
LSFCW63	63mm Standard LSF	1
LSFCW75	75mm Standard LSF	1

Type BWR Three Part Gland

- For use with all types of SWA cables to BS6346
- For use indoors in dry locations
- Positive armour locking, effective earth continuity, increased mechanical strength

Type BWR Three Part Gland		
Reference	Description	Quantity
BWR20S	20mm Small	2
BWR20	20mm Standard	2
BWR25	25mm Standard	2
BWR32	32mm Standard	2
BWR40	40mm Standard	1
BWR50	50mm Standard	1
BWR63	63mm Standard	1
BWR75	75mm Standard	1



Type E1W Industrial Gland

- For use with all types of SWA cables to BS6346
- Application indoor and outdoor whenever it is required to provide sealing on cable outer sheath as well as inner sheath
- E1W glands are weatherproof and can be used in corrosive conditions when protected with a shroud

Type E1W Industrial Gland		
Reference	Description	Quantity
E1W20S	20mm Small	2
E1W20	20mm Standard	2
E1W25	25mm Standard	2
E1W32	32mm Standard	2
E1W40	40mm Standard	1
E1W50	50mm Standard	1
E1W63	63mm Standard	1
E1W75	75mm Standard	1



Type LXT Light Duty Industrial Gland

- For use with flexible wire braided cable e.g. SY/CY cable

Type LXT Industrial Gland		
Ref	Description	Quantity
LXT20S	20mm Small	2
LXT20	20mm Standard	2
LXT25	25mm Standard	2
LXT32	32mm Standard	2
LXT40	40mm Standard	1
LXT50	50mm Standard	1



NYLON CABLE GLANDS

HellermannTyton nylon dome headed cable glands are quick and easy to install and cater for a wide range of cable sizes.

A range of quality nylon cable glands, that can be used on a wide range of applications when connecting cable to electrical equipment, (but not steel wire armoured cable).

Testing to IP68 provides protection against the ingress of dust and water. No need to dismantle the gland, just insert the cable and tighten.



- Material Nylon 66
- IP Rating IP68
- Metric thread
- Available in red, black, white and grey
- Euro slot packaging

Stock Code	Size	Colour	Cable Clamp Range	Pack Quantity
NGM12-RED	M12	RED	3-6.5 mm	10
NGM16-RED	M16	RED	5-10 mm	10
NGM20S-RED	M20	RED	6-12 mm	10
NGM20-RED	M20	RED	10-14 mm	10
NGM25-RED	M25	RED	13-18 mm	10
NGM32-RED	M32	RED	18-25 mm	5
NGM12-WHT	M12	WHITE	3-6.5 mm	10
NGM16-WHT	M16	WHITE	5-10 mm	10
NGM20S-WHT	M20	WHITE	6-12 mm	10
NGM20-WHT	M20	WHITE	10-14 mm	10
NGM25-WHT	M25	WHITE	13-18 mm	10
NGM32-WHT	M32	WHITE	18-25 mm	5
NGM12-GRY	M12	GREY	3-6.5 mm	10
NGM16-GRY	M16	GREY	5-10 mm	10
NGM20S-GRY	M20	GREY	6-12 mm	10
NGM20-GRY	M20	GREY	10-14 mm	10
NGM25-GRY	M25	GREY	13-18 mm	10
NGM32-GRY	M32	GREY	18-25 mm	5
NGM12-BLK	M12	BLACK	3-6.5 mm	10
NGM16-BLK	M16	BLACK	5-10 mm	10
NGM20S-BLK	M20	BLACK	6-12 mm	10
NGM20-BLK	M20	BLACK	10-14 mm	10
NGM25-BLK	M25	BLACK	13-18 mm	10
NGM32-BLK	M32	BLACK	18-25 mm	5
NGM40-BLK	M40	BLACK	22-32 mm	5
NGM50-BLK	M50	BLACK	30-38mm	2
NGM63-BLK	M63	BLACK	34-44mm	2

Plaster Board Fixing - Self Tapping

Plasterboard Screws

- Self drilling anchor for plasterboard
- Anchors complete with screws
- Zinc alloy

Twister Plaster Board Fixing - Self Tapping		
Reference	Material	Pack Qty
43000350/V63225	Zinc Alloy	100



NYLON CABLE GLANDS



• We offer a whole range of cable management *Solutions*

For more information call our sales team on - **01922 458151**
Alternatively email us at - distribution@hellermannntyton.co.uk

HellermannTyton
www.hellermannntyton.co.uk

HellermannTyton



Welcome to the world of perfect cable management solutions.

To find out more contact us: **01922 458 151** distribution@hellermannntyton.co.uk

www.hellermannntyton.co.uk

HelaCon Plus Series Wire Connectors

The HelaCon range of push-in wire connectors are used for fast, easy reliable connection and distribution of cable and conductors in electrical housing applications.

They are used within a typical voltage up to 450 volts. A huge variety of input poles allow a high flexibility in application depending on the number of conductors and available space.

Diameters of up to 2.5mm² can conveniently be processed and allow the use of thicker conductors when a voltage drop occurs. The flexible fixing of the double spring of HelaCon Plus allows different conductor diameters in each entry without influencing the adjacent ones. The connectors can be used in all kinds of junction boxes either on-wall or flush mounted.

The HelaCon connectors are used for fast, easy and reliable connection and distribution of cable and conductors in the field of electrical housing installations within junction boxes and control panels.



HelaCon Plus used in a wall mounted junction box.

Working with clear visibility

Screwless connectors in the field of house installations are used countless times every day. Although this is routine work it requires a lot of diligence in installing the connectors. A tight and secure fitting is indispensable for a failure-free long life operation. Less care may otherwise result in damage and overheating, worst case causing a very hazardous situation like a fire.

The transparent housing of the HelaCon Plus connector series allows a fast and easy optical control whether the conductor fits to the catch. This is a non negligible factor for safety and will expedite acceptance test of the complete electrical installation.

Newly developed double spring technology

The more connectors that are used for wiring a connection the more important it is to handle and process them very easily and conveniently.

Along with a secured fitting this was the utmost aim of the development of the double spring technology. Both springs have major roles to play. The first one allows very low push-in forces that is especially helpful when using soft conductors. The second spring secures the fixing very tightly. This results in a comfortable use of the connectors and maximum safety at the same time.

Different wire types and cross-section

The low push-in force due to the latest double spring technology enables the use of single and multicore conductors.

The free fixing of each double spring allows the concurrent use of various conductor cross-section between 0.5 and 2.5mm² within one connector without impact on the adjacent connection. Please note that HelaCon Plus is not designed for fine-stranded wires.



Easy push-in, safe fitting and optical check due to newly developed double spring technology.

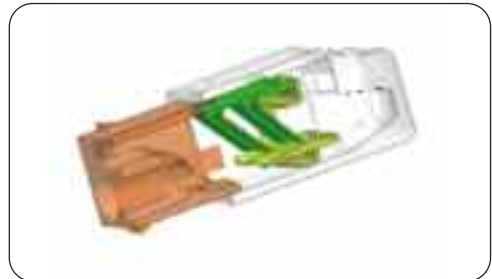

Sectional drawing of HelaCon Plus.



View through the housing shows the double spring.



Any cross-section between 0.5 and 2.5mm² can be used concurrently.

HelaCon Plus

Features and Benefits:

HelaCon Plus is a sophisticated push-in wire connector for professional cable connections in electrical housing applications.

The newly developed double spring allows easy processing and will support installers especially in tricky situations like overhead work. This ensures proper fixing that can optically be checked through the transparent housings.

Different colour codes provide a comfortable identification of the different connectors. A separate voltage test entry on the front guarantees safety during application, installation and maintenance.

Application

The HelaCon connectors are used for fast, easy and reliable connection and distribution of cable and conductors in the field of electrical housing applications.

Application Method

- Make sure that power is turned off before installation
- Solid and stranded copper conductors can be used
- Strip them off approximately 11mm
- Insert them completely into the connector
- Use voltage tester via separate test entry
- To change or connect a wire, hold and twist it alternatively left and right while pulling the connector.



A huge variety of connectors from 2 to 8 poles is available according to the application. The transparent housing allows a quick and easy check of the conductor fitting.

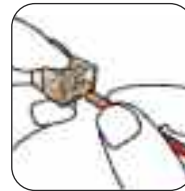

The double spring allows easy push-in of the connector.



HelaCon Plus - newly developed double spring technology.

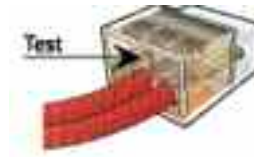

A separate test entry on the front allows the use of a voltage meter



Solid 0.5-2.5mm



Fine stranded



HECP-3



HECP-5



HECP-2



HECP-3



HECP-4



HECP-5



HECP-6



HECP-8

Material Data Table	
Material Housing	Polycarbonate (PC)
Material Plated Brass	Brass tinned
Material Spring Plate	Stainless Steel
Max Current	24 A
Max Voltage	450 V (VDE), 600 V (cULus)
Wire Range (cULus)	AWG 12 to 22 solid/stranded
Wire Range (VDE)	0.5 to 2.5mm ² solid/stranded (max 7 cores)
Stripping Length	11mm
Flammability	UL94 VO
Operating Temperature	-30°C to +110°C (VDE), -30°C to +105°C (cULus)
Specification	VDE, NEMKO, SEMKO, FIMKO, DEMKO, KEMA-KEUR, cULus.



HelaCon Plus						
Reference	Colour	No. of Conductors	Width (W) mm	Height (H) mm	Depth (D) mm	Pack Cont.
HECP-2	Transparent (CL), Yellow (YE)	2	11.75	10.45	19.00	100
HECP-3	Transparent (CL), Orange (OG)	3	15.90	10.45	19.00	100
HECP-4	Transparent (CL)	4	20.05	10.45	19.00	75
HECP-5	Transparent (CL), Blue (BU)	5	24.20	10.45	19.00	50
HECP-6	Transparent (CL), Violet (VT)	6	28.35	10.45	19.00	50
HECP-8	Transparent (CL), Grey (GY)	8	36.65	10.45	19.00	40

HelaCon Plus 32AMP Push-In Wire Connectors Releasable

A 32Amp 450V releasable push in wire connector used for fast, easy and reliable Connection of lighting and power circuits.

- Suitable for 0.5mm² to 4mm² solid/stranded cable and also flexible cable to 2.5mm²
- Can be released using special tool (supplied in carton)
- 3 poles

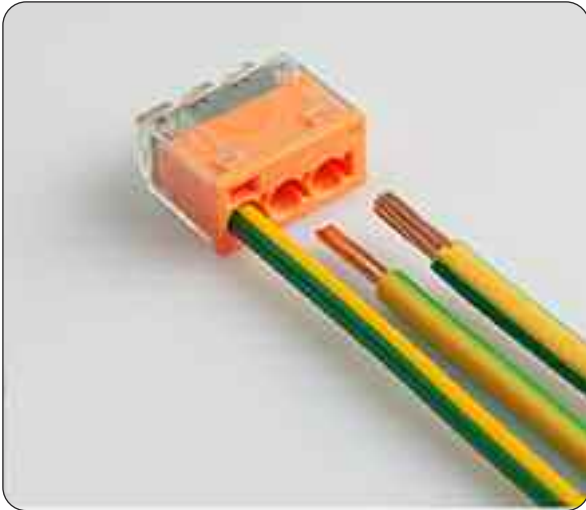

Material Data Table	
Material Housing	Polycarbonate (PC)
Insert	Copper plate, tin-plated, stainless spring steel
Steel Frame	Tin Plated
Flammability	UL94V-2
Operating Temps	T100°C (IEC) 105°C/221°C (UL)
Rated	600v Max. for bundling/wiring and 1000v max. for lighting/fixtures/luminaries and signs

Reference	Poles	Colour	Qty
HECP3-32A	3	Orange (OG)	75

Tool for HelaCon 32AMP Push-in Wire Connectors



Reference	Description	Qty
HECP3-32A - TOOL	Tool	1

HelaCon Lux

Features and Benefits:

HelaCon Lux is best suitable to connect solid and flexible wire. It combines the push-in connector technology that is well known from HelaCon Plus with a lock/unlock spring mechanism to connect fine-stranded conductors. They may be used within a typical housing range of 450 V / 24 A.

The two available variants showing either one or two inputs for solid conductor on the installation side offer high flexibility in application.

Instead of using screwed terminal blocks the tool-free application of the lighting connectors results in an easy, time-saving and safe connection of conductors. The user benefits from this especially in overhead work and when wires are difficult to access

Application

A typical application is lighting installation, where the solid conductor from concealed cabling has to be connected to a flexible conductor for lightings. The 2/1 variant allows the looping through of the supply lines for additional devices.

The conductor on the output/lighting side can easily be inserted by pressing the locking mechanism and can be released in the same way at any time. The lighting side can carry any kind of conductor and makes HelaCon Lux connectors also useful to connect devices that carry flexible connecting cables like control devices e.g. for blinds, fans and other drives.

Application Method

- Do not work under load
- Strip off the conductors 9 - 11 mm
- Push in the solid conductor into the round input on the installation side
- Unlock the lighting side by pressing the connector's rectangular input
- Insert the lighting conductor and release the connector
- To remove, simply press the connector again and withdraw the conductor
- The installation side can easily be removed by twisting and pulling the conductor
- The test entry can be used to check the voltage with a meter

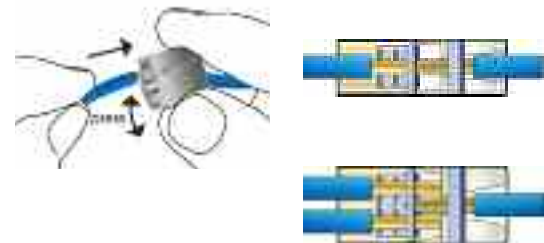

Tool free connection of lightings.



Installation side 0.75 – 2.5mm² solid.

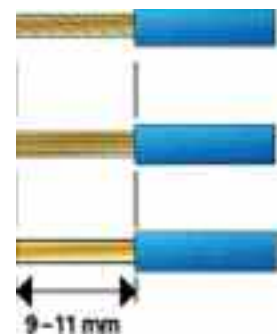

Lighting side 0.5 – 2.5mm² solid, stranded, fine stranded.



HelaCon Lux 1/1



HelaCon Lux 2/1



Material Data Table	
Material Housing	Polyamide 6.6 (PA66)
Max Currents	24 A
Max Voltage	450 V
Wire Range (VDE)	0.5 (0.75) – 2.5mm ²
Stripping Length	11mm
Flammability	UL94 V2
Wire Range (VDE)	0.5 to 2.5mm ² solid/stranded (max 7 cores)
Stripping Length	11mm
Flammability	UL94 VO
Operating Temperature	-5°C to +100°C
Certification	VDE, FMKO, cULus, KEMA-KEUR, CEBC, ENEC.



HelaCon Lux						
Reference	Colour	No. of Conductors	Width (W)	Height (H)	Depth (D)	Pack Cont.
HECL-1/1	Grey (GY)	2	8.1	15.8	20.8	100
HECL-2/1	White (WH)	3	9.5	15.8	20.8	100

HellermannTyton now offer two types of **HelaCon Kit**, the **BIG ONE** or the **LITTLE ONE!** Each comes in it's own handy top quality case which can be refilled over and over again.

'THE BIG ONE'



NEW HelaCon Kit

The HelaCon range of plastic wire connectors are used for fast, easy and reliable connection and distribution of cable and conductors in electrical housing applications.

This new kit contains 740 pieces and comes in a top quality case which can be refilled over and over again.

Kit contents are:

200	HECP-2
200	HECP-3
150	HECP-4
100	HECP-5
50	HECP-6
40	HECP-8



Type	Desc
148-00107	Helacon Kit

'THE LITTLE ONE'



HelaCon Kit

The smaller kit contains 100 pieces of connectors and comes in a top quality carrying case, which again can be refilled over and over again.

Kit contents are:

15	HECP-2
40	HECP-3
8	HECP-4
25	HECP-5
6	HECP-6
8	HECP-8



Type	Desc
148-00077	Helacon Kit

Connector Box



Connector Box ⁺

HTCB+

HellermannTyton has manufactured its own enclosure to house terminal strips. A thermo plastic (polypropylene) enclosure, which can be used as a junction box for fixed wiring and when used in conjunction with the cable restraints (supplied) can also be used as an in-line connector for such applications as terminating solid/stranded cable to flexible cable. Its tapered pin allows ease when locating the connector strip within the housing.

Contents include:

- 1 x connector box enclosure
- 2 x cable restraints
- 4 screws 12.5mm x 3mm (for cable restraints)
- 2 x screws 19.5mm x 3mm (for box lid)
- Screws and cable restraints are packed separately to save contractors assembly time
- Supplied in a trade counter merchandiser in quantities of 50

Dimensions: 109mm x 52mm x 28mm

Voltage: 250 V AC

The HTCB+ is designed to take up to 4 pole 15/16A terminal strips across its width enabling wiring of typical lighting circuit with cabling loop in, loop out, switch and light, for example.



Reference	Description
HTCB+	Connector Box

PE Terminal Strip Connectors

New range of terminal strips:

- 3, 5, 15, 30 & 60 amp
- Polyethylene (80°C)
- Packed 10 strips of 12 poles
- colours natural (NT) or black (BK)



Material	Type	Specification
PE	CS3NT	3A-4mm
PE	CS5NT	5A-6mm
PE	CS15NT	15A-12mm
PE	CS30NT	30A-16mm
PE	CS60NT	60A-25mm

Material	Type	Specification
PE	CS3BK	3A-4mm
PE	CS5BK	5A-6mm
PE	CS15BK	15A-12mm
PE	CS30BK	30A-16mm
PE	CS60BK	60A-25mm



PP Terminal Strip Connectors

3, 5, 15, 30 & 60 Amp

Polypropylene (-20°C +90°C)

Colour : White

Packed 10 strips of 12 poles

Material	Type	Specification
PP	CS3WT-PP	3A-4mm
PP	CS5WT-PP	5A-6mm
PP	CS15WT-PP	15A-12mm
PP	CS30WT-PP	30A-16mm
PP	CS60WT-PP	60A-25mm



Sigma terminals

Terminals made of self-extinguishing Polyamide-6. Black base, terminal made of MS-58 brass (DIN-17660), ring made of tempered, galvanised and bichromated steel and cap made of self-extinguishing orange polypropylene.

- Clipping proof. The connection is done through a tightening device that presses evenly all of the contact surface, avoiding frictions and strains that could damage the conductors.
 - Loosening proof. The ring that surrounds the brass body guarantees that the pressure exerted by the conductors will not open the terminal and loosen the connection.
 - Total insulation. All SIGMA "S" terminals are supplied with a cap, which avoids any accidental contacts with live parts.
- All sizes can be joined together. Nominal current: 500 V.















Sigma Modular Line Taps			
Reference	Cross Section & Ampage	Amps	Pack Qty
NSYS04	4mm ² Cable	25A	20
NSYS06	6mm ² Cable	32A	20
NSYS10	10mm ² Cable	50A	20
NSYS16	16mm ² Cable	63A	20
NSYS25/35	25-35mm ² Cable	100A	20
NSYS50	50mm ² Cable	125A	20
NSYS70	70mm ² Cable	160A	20
NSYS95/100	95-100mm ² Cable	200A	20

Pre-Insulated Light Duty Terminals

Sizes:

- Red Insulation 0.5-1.5mm²
- Blue Insulation 1.5-2.5mm²
- Yellow Insulation 4.0-6.0mm²
- Material: Copper Tin Plated. Sleeve PVC
- Retail packaging
- RoHS
- UL



Light Duty Terminals	TYPE	MM	Red Pre-insulated Part No	Pack Size	Blue Pre-insulated Part No	Pack Size	Yellow Pre-insulated Part No	Pack Size
Ring 	RING	3	HFP1.5-003	100	HFP2.5-003	100	-	-
		3.5	HFP1.5-003.5	100	HFP2.5-003.5	100	HFP4.0-003.5	100
		4	HFP1.5-004	100	HFP2.5-004	100	HFP4.0-004	100
		5	HFP1.5-005	100	HFP2.5-005	100	HFP4.0-005	100
		6	HFP1.5-006	100	HFP2.5-006	100	HFP4.0-006	100
		10	HFP1.5-010	100	HFP2.5-010	100	HFP4.0-010	100
Fork 	FORK	3	HFP1.5-S3	100	-	-	-	-
		3.5	HFP1.5-S3.5	100	HFP2.5-S3.5	100	HFP4.0-S3.5	100
		4	HFP1.5-S4	100	HFP2.5-S4	100	-	-
		5	HFP1.5-S5	100	HFP2.5-S5	100	HFP4.0-S5	100
Pin 	FORK	6	HFP1.5-S6	100	HFP2.5-S6	100	HFP4.0-S6	100
		8	HFP1.5-S8	100	HFP2.5-S8	100	HFP4.0-S8	100
		10	HFP1.5-S10	100	HFP2.5-S10	100	HFP4.0-S10	100
		12	HFP1.5-S12	100	HFP2.5-S12	100	HFP4.0-S12	100
Flat Blade 	FLAT BLADE	Pin Length 12	HFP1.5-WP12	100	HFP2.5-WP12	100	HFP4.0-WP14	100
		Blade Size 9.0 x 2.8	-	-	HFP2.5-FB9	100	-	-
Hook Blade 	HOOK BLADE	18.0 x 2.3	HFP1.5-FB18	100	HFP2.5-FB18	100	-	-
		10.0 x 2.3	HFP1.5-FB10	100	-	-	-	-
Butt 	BUTT	Blade Width 3.0	HFP1.5-HB	100	HFP2.5-HB	100	-	-
		-	HFP1.5-BC	100	HFP2.5-BC	100	HFP4.0-BC	100
Female Push On 	FEMALE PUSH ON	To fit Tab 2.8 x 0.6	HFP1.5-F119-S	100	-	-	-	-
		2.8 x 0.8	HFP1.5-F119-S	100	-	-	-	-
		4.7 x 0.5	HFP1.5-F187-S	100	HFP2.5-F187-S	100	-	-
		4.7 x 0.8	HFP1.5-F187-S	100	HFP2.5-F187-S	100	-	-
		5.3 x 0.8	HFP1.5-F250-S	100	HFP2.5-F250-S	100	HFP4.0-F250-S	100
		9.5 x 1.0	-	-	-	-	HFP4.0-F375-S	100
Male Push On 	MALE PUSH ON	6.3 x 0.8	HFP1.5-M250-S	100	HFP2.5-M250-S	100	HFP4.0-M250-S	100
		To fit Tab 6.3 x 0.8	HFP1.5-FS250-S	100	HFPT2.5FS250-S	100	-	-
Female fully insulated 	INSULATED	6.3 x 0.8	-	-	HFP2.5-F250-S	100	HFP4.0-FS250-S	100
		6.3 x 0.8	HFP1.5-MF250-S	100	HFP2.5-MF250-S	100	-	-
Push On Adaptor 	PUSH ON ADAPTOR	6.3 x 0.8	-	-	-	-	-	
Male Bullet Connector 	MALE BULLET CONNECTOR	4	HFP1.5-MB	100	HFP2.5-MB	100	-	-
Female Bullet Connector 	FEMALE BULLET CONNECTOR	4	HFP1.5-FB	100	HFP2.5-FB	100	-	-

630 Piece Terminal Kit

- 0.5-6mm cable diameter
- Colour coded pre-insulated
- Quality steel carry box
- Cutting tool
- Ratchet crimper
- Cable Ties included



630 Piece Terminal Kits
Reference
A801632T



Pre-Insulated End Sleeve Terminals

A comprehensive range of pre-insulated end sleeve terminals available in both French and German standard colour codings.

Pre-Insulated End Sleeve Terminals					
Type	Reference	Cable Size	Colour	Pack Qty	
Pre-Insulated End Sleeve French Colour 	CE005008	0.50mm x 8F	White	500	
	CE075008	0.75mm x 8F	Blue	500	
	CE010008	1.0mm x 8F	Red	500	
	CE015008	1.5mm x 8F	Black	500	
	CE025008	2.5mm x 8F	Grey	500	
	CE040010	4.0mm x 10F	Orange	500	
	CE060012	6.0mm x 12F	Green	100	
	CE100012	10mm x 12F	Brown	100	
	CE160012	16mm x 12F	Ivory	100	
	CE250016	25mm x 16F	Black	100	
	CE350016	35mm x 16F	Red	50	
	CE500020	50mm x 20F	Blue	50	
	German Colour 	CE005008W	0.50mm x 8G	Orange	500
		CE075008W	0.75mm x 8G	White	500
CE010008W		1.0mm x 8G	Yellow	500	
CE015008W		1.5mm x 8G	Red	500	
CE25008W		2.5mm x 8G	Blue	500	
CE040010W		4.0mm x 10G	Grey	500	
CE0060012W		6.0mm x 12G	Black	100	

Sizes 10mm - 50mm in German Colour Codes available to special order.

Pre-Insulated Twin End Sleeve Terminals

Pre-Insulated End Sleeve Terminals					
Type	Reference	Cable Size	Colour	Pin Length	Pack Qty
Pre-Insulated Twin End Sleeve 	CT205008	2 x 0.5	White	8mm	1000
	CT207508	2 x 0.75	Grey	8mm	1000
	CT207510	2 x 0.75	Grey	10mm	1000
	CT210008	2 x 1.0	Red	8mm	1000
	CT210010	2 x 1.0	Red	10mm	1000
	CT215008	2 x 1.5	Black	8mm	1000
	CT225013	2 x 2.5	Blue	13mm	1000
	CT225010	2 x 2.5	Grey	10mm	1000
	CT225013	2 x 2.5	Grey	13mm	1000
	CT240013	2 x 4.0	Grey	13mm	1000
	CT260014	2 x 6.0	Yellow	14mm	1000

Copper Tube Terminals & Copper Tube Splices

• HCT/HCBS Series

Suitable for the termination of cables and stud connectors and splices for joining cable together.

- Material: High conductivity copper BS EN12449
- Purity: >99.9%
- Coating: Electro Tin Plating to BS1872
- Terminals have flared (bell mouth) entry for ease of cable insertion
- Terminals have inspection holes to check that the cable is inserted properly before terminal is crimped
- Range covers cable sizes from 6mm to 300mm
- Packed in polythene (PE) bags with Euro slot



HCT SERIES

Copper Tube Terminal			
Reference	To fit Cable Size mm ²	Stud Dia	Pack Qty
HCT 6-4	6	4mm	100
HCT 6-6	6	6mm	100
HCT 6-8	6	8mm	100
HCT 6-10	6	10mm	100
HCT 10-6	10	6mm	100
HCT 10-8	10	8mm	100
HCT 10-10	10	10mm	100
HCT 10-12	10	12mm	100
HCT 16-6	16	6mm	100
HCT 16-8	16	8mm	100
HCT 16-10	16	10mm	100
HCT 16-12	16	12mm	100
HCT 25-6	25	6mm	100
HCT 25-8	25	8mm	100
HCT 25-10	25	10mm	100
HCT 25-12	25	12mm	100
HCT 35-6	35	6mm	100
HCT 35-8	35	8mm	100
HCT 35-10	35	10mm	100
HCT 35-12	35	12mm	100
HCT50-6	50	6mm	50
HCT 50-8	50	8mm	50
HCT 50-10	50	10mm	50
HCT 50-12	50	12mm	50
HCT 70-6	70	6mm	50
HCT 70-8	70	8mm	50
HCT 70-10	70	10mm	50
HCT 70-12	70	12mm	50
HCT 70-14	70	14mm	50
HCT 70-16	70	16mm	50
HCT 95-8	95	8mm	5
HCT 95-10	95	10mm	5
HCT 95-12	95	12mm	5
HCT 95-14	95	14mm	5
HCT 95-16	95	16mm	5
HCT120-8	120	8mm	5
HCT 120-10	120	10mm	5
HCT 120-12	120	12mm	5
HCT120-14	120	14mm	5
HCT 120-16	120	16mm	5

HCBS SERIES

Copper Tube Terminal			
Reference	To fit Cable Size mm ²	Stud Dia	Pack Qty
HCT 150-10	150	10mm	5
HCT 150-12	150	12mm	5
HCT150-14	150	14mm	5
HCT150-16	150	16mm	5
HCT 185-10	185	10mm	5
HCT 185-12	185	12mm	5
HCT 185-14	184	14mm	5
HCT 185-16	185	16mm	5
HCT240-10	240	10mm	5
HCT240-12	240	12mm	5
HCT 300-10	300	10mm	5
HCT 300-12	300	12mm	5
HCT 300-16	300	16mm	5

Copper Tube Butt Splice

Reference	Cable Cross section (mm ²)	Pack Qty
HCBS-6	6	50
HCBS10	10	25
HCBS-16	16	25
HCBS-25	25	25
HCBS-35	35	25
HCBS-50	50	10
HCBS-70	70	10
HCBS-95	95	10
HCBS-120	120	5
HCBS-150	150	5
HCBS-185	185	5
HCBS-240	240	5
HCBS-300	300	5



Full range of tooling available on page 68

Ratchet Crimp Tools for Pre-insulated Terminals

7700 - Ratchet

- Size - 8³/₅" , 220mm
- Crimp range - 0.5 - 6.0mm

Ratchet		
Reference	Crimp Type	Crimp Range
7700	Pre Insulated L/Duty	0.5 - 6.0mm



7700

7702 - Ratchet

- Size - 8³/₅" , 220mm
- Crimp range - 0.5 - 4.0mm

Ratchet		
Reference	Crimp Type	Crimp Range
7702	Pre Insulated End Sleeve	0.5 - 4.0mm

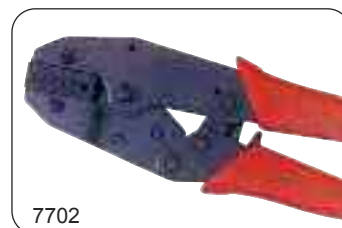

7702

7703 – Ratchet for End Sleeves

- Size - 8³/₅" , 220mm
- Crimp range - 6, 10, 16mm

Ratchet		
Reference	Crimp Type	Crimp Range
7703	Pre-insulated End Sleeves	6, 10 & - 16mm



7703

Ratchet Tools for Non Insulated Copper Tube Terminals

Ref	Crimp Type	Crimp Range
6095	Heavy duty indent	10mm-95mm ²
60150	Heavy duty indent	10mm-150mm ²
7701516	Medium duty indent	0.5mm-16mm ²
7800	Medium duty indent	1.5mm-16mm ²
7725	Medium duty indent	10mm-25mm ²
8038	Medium duty indent	6mm-35mm ²
60050H	Medium duty hexagonal	6mm-50mm ²
60120H	Medium duty hexagonal	10mm-120mm ²

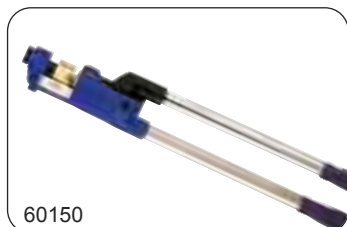

60150



6095

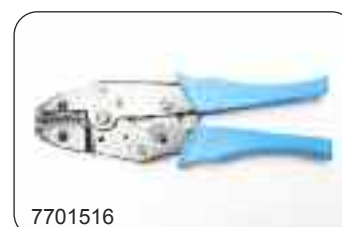

7701516



60050H + 60120H



7725, 7800 + 8038

Feed Through Rail Mount Terminal Blocks

- Conforms to all major international standards including UL, cUL, CSA, KEMA and LR
- Ex-e Certified
- Self extinguishing UL94V-0 material
- Polyamide material for use between -30°C to +110°C
- Full range of accessories available
- Current ratings up to 192 Amps (to IEC standards)
- Top Hat / G Rail
- Blue EXI version available on request

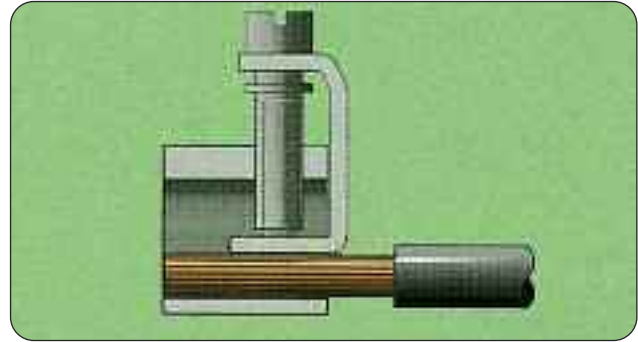

Feed Through Rail Mount Terminal Blocks				
Reference	Rated Wire (flexible)	Current Rating	Terminal Width	Pack Qty
CBD.2	0.5-4mm ²	24A	5.5	10
CBD.4	0.5-6mm ²	32A	6.5	10
CBD.6	0.5-10mm ²	41A	8	10
CBD.10	0.5-16mm ²	57A	10	10
CBD.16	0.5-25mm ²	76A	12	5
CBD.35	0.5-35mm ²	101A	16	5
CBD.50	1.5-50mm ²	125A	18	5
CBD.70	1.5-95mm ²	192A	20.5	5

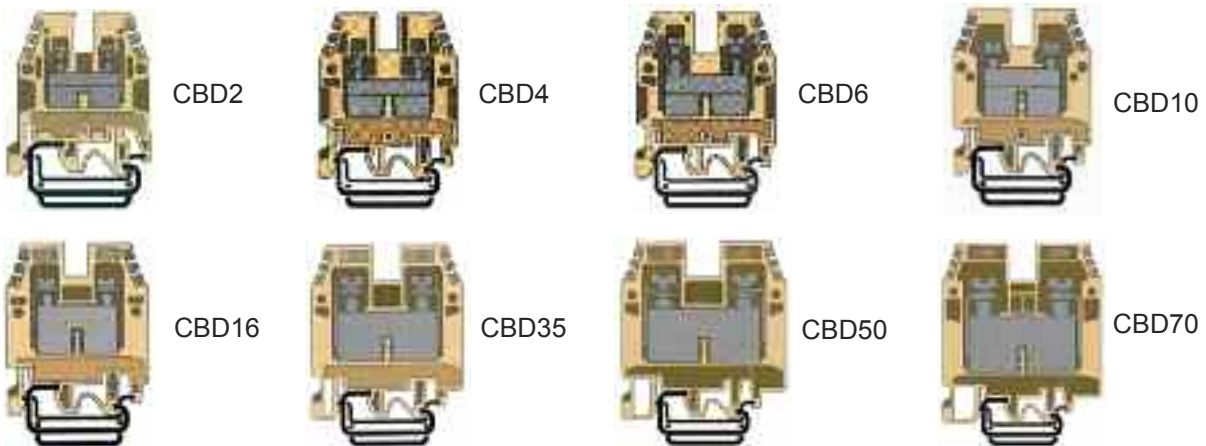

End Sections for Above Terminals		
Reference	Description	Pack Qty
CB.2/PT	End Section For CBD.2	10
CB.4/6/PT	End Section For CBD.4 & CBD.6	10
CB.10/PT	End Section For CBD.10	10
CB.16/PT	End Section For CBD.16	5
CB.35/PT	End Section For CBD.35	5
CB.50/PT	End Section For CBD.50	5
CB.70/PT	End Section For CBD.70	5



CBC SERIES RAIL MOUNTED TERMINAL BLOCKS

- These new terminal blocks offer reduced overall dimension, resulting in high compactness.
- Same overall dimensions from 2.5mm to 10mm²
- Patented 'easy bridge' system: doubles the possibility to insert PTC multi cross-connections, without the need of insulating protection.
- High conductivity with 3 products able to cover the needs normally satisfied by 6 terminals.
- UL94V-0 polyamide insulating body
- Suited for photovoltaic plants with rated voltage up to 100 vdc
- KEMA, UL, R.I.NA, ATEX and IEC Ex Certified



Ratings

CBC SERIES	CBC.2/GR	CBC.4/GR	CBC.6/GR	CBC.10/GR	TEO.4/0	TEC.6/0	TEC.10/0
Electrical function	Feed through	Feed through	Feed through	Feed through	Earth	Earth	Earth
Rated cross-section (mm ²)	2.5	4	6	10	4	6	10
Rated voltage (V)	1000	1000	1000	1000	-	-	-
Rated current (A)	32	41	57	76	-	-	-

Terminal Blocks

MOQ Pack

CBC.2/GR Feed Through Terminal Block	120
CBC.4/GR Feed Through Terminal Block	100
CBC.6/GR Feed Through Terminal Block	100
CBC.10/GR Feed Through Terminal Block	100
TEO.4/0 Earth Terminal Block	1
TEC.6/0 Earth Terminal Block	1
TEC.10/0 Earth Terminal Block	1

Accessories

MOQ Pack

CBC.2-10/PT/GR End Section	50
PTC/2/10 10 pole plug in jumper	25
PTC/4/10 pole plug in jumper	25
PTC/6/10 pole plug in jumper	25
PTC/10/10 pole plug in jumper	10
PTC/SP jumper marking strip	10
DFM900 jumper barrier	50
CNU8 marking tags	500
BTO end bracket	25



Earth Terminals

- Polyamide insulator
- Available as 35mm Top Hat and 32mm G Rail types in screw clamp fixing form
- TEO.2 earth terminal, suitable for 35mm Top Hat rail mounting through blade connect system to rail
- Copper/zinc alloy, high percentage of copper conductor

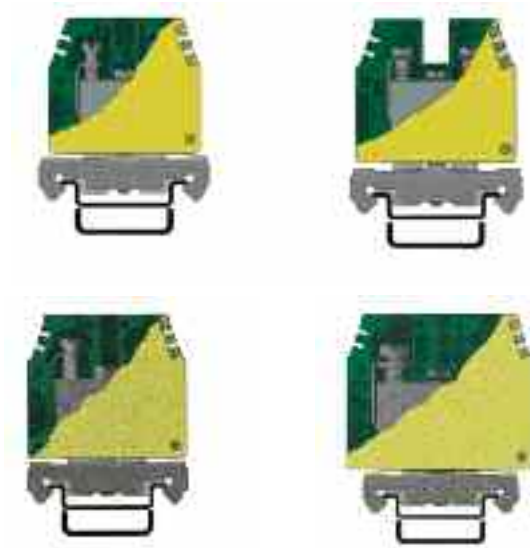

Earth Terminals			
Reference	Rated Wire	Description	Pack Qty
TEO.2	Earth Terminal 2.5mm ²	35mm Rail	1
TEO.4	Earth Terminal 4mm ²	35mm Rail	1
TE.6/0	Earth Terminal 6mm ²	35mm Rail	1
TE.10/0	Earth Terminal 10mm ²	35mm Rail	1
TE.16/0	Earth Terminal 16mm ²	35mm Rail	1
TE.50/0	Earth Terminal 50mm ²	35mm Rail	1
TE.4/D	Earth Terminal 4mm ²	G Rail	1
TE.6/D	Earth Terminal 6mm ²	G Rail	1
TE.10/D	Earth Terminal 10mm ²	G Rail	1
TE.16/D	Earth Terminal 16mm ²	G Rail	1
TE.50/D	Earth Terminal 50mm ²	G Rail	1
CBC2/4PT	End section for TEO.4 terminal		50

Cross Connections

For connecting 2 or more terminals via link.

Screw and distance sleeve included with 2 way kit, to be ordered separately for multipole commoning bar.



Cross Connections			
Reference	Description	For Terminal Type	Pack Qty
PMP/01	45 Way Multiple Connecting Bar	CBD.2	2M (8x250mm)
PMP/42	38 Way Multiple Connecting Bar	CBD.4	2M (8x250mm)
PMP/13	31 Way Multiple Connecting Bar	CBD.6	2M (8x250mm)
PMP/04	25 Way Multiple Connecting Bar	CBD.10	2M (8x250mm)
PMP/05	21 Way Multiple Connecting Bar	CBD.16	2M (8x250mm)
PMP/06	16 Way Multiple Connecting Bar	CBD.35	2M (8x250mm)
PMP/07	14 Way Multiple Connecting Bar	CBD.50	2M (8x250mm)
PMP/08	12 Way Multiple Connecting Bar	CBD.70	2M (8x250mm)
CPM/21	Screw And Distance Sleeve For PMP/01	CBD.2	25
CPM/12	Screw And Distance Sleeve For PMP/42	CBD.4	25
CPM/83	Screw And Distance Sleeve For PMP/13	CBD.6	25
CPM/03	Screw And Distance Sleeve For PMP/04	CBD.10	25
CPM/44	Screw And Distance Sleeve For PMP/05	CBD.16	25
CPM/06	Screw And Distance Sleeve For PMP/06	CBD.35	10
CPM/07	Screw And Distance Sleeve For PMP/07	CBD.50	10
CPM/08	Screw And Distance Sleeve For PMP/08	CBD.70	15
POF/44	2 Way Link Including Distance Sleeve/Screws	CBD.16	25
POF/06	2 Way Link Including Distance Sleeve/Screws	CBD.35	15
POF/07	2 Way Link Including Distance Sleeve/Screws	CBD.50	15
POF/08	2 Way Link Including Distance Sleeve/Screws	CBD.70	15

End Brackets

- Top hat or G Rail end brackets



End Brackets		
Reference	Description	Pack Quantity
BT/3	End Bracket For 35mm Top Hat Rail	25
BT/DIN/PO	End Bracket For 32mm G Type Rail	25
BT/U	Universal End Bracket 32/35mm Top Hat/G-Type Rail	25

Coloured Partitions For Rail Mount Terminals

Manufactured in polyamide and available in red only. Used for the separation of elements on the terminal board, in order to make certain circuits easy to locate or to increase the insulation distances between terminal blocks.

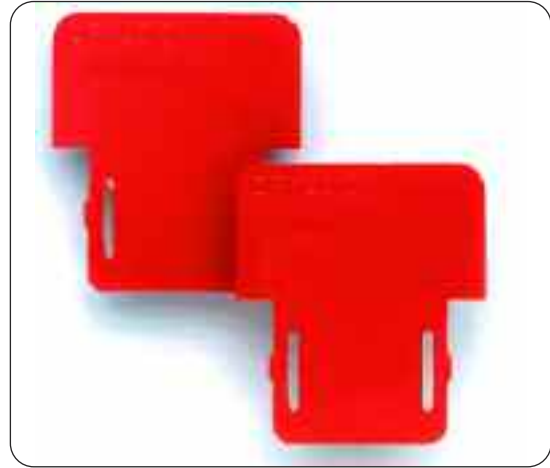

Coloured Partitions		Pack Qty
Reference	To Fit Screw Clamp Terminal	
DFU/1	CBD.2,	50
DFU/4	CBD.4, CBD.6, CBD.10, CBD.16	50
DFU/5	CBD.25, CBD.35	25
DFU/6	CBD.70	25

Quick Attaching Clip-on Marker

Quick attaching clip-on marker tags allowing the composition of identification markings, also alphanumerical for circuits.



Type CSC/		
Reference	Composition	Minimum Order
CSC/09	Blank	500 Tags
For other identical numbers/letters the reference is CSC/(state number or letter required)		

Marking Systems

Marking tags ideal for marking all terminals, the black on white marker is attached directly into position either before or after composition of the terminal board.



Type CNU/8/			
Reference	Description	Marking	Minimum Order Qty
CNU/8/001		1 to 50	500
CNU/8/051		51 to 100	500
CNU/8/301		301 to 350	500
For other progressive series of 50 digits the reference is CNU/8/state the initial number			
CNU/8/510		1 to 10	500
CNU/8/600		91 to 100	500
CNU/8/030	Blank Marker Card	Blank	500
CB/CTL/BLACK	Black Marker Pen		1



HelaCon

HECP3-32

"A new edition to the HelaCon family"



- 32 Amp Rated
- Cable size/type:
 - 0.5-4.0mm² - Solid & Stranded
 - 0.5-2.5mm² Flexible
- Releasable
- Versatile...accepts Solid, Stranded & Flexible cables in the same connector
- ENEC approval
- Double Spring Technology

HellermannTyton
www.hellermanntyton.co.uk

For more information call our sales team on **01922 458151**
Alternatively email us at distribution@hellermanntyton.co.uk



Welcome to the world of perfect cable management solutions.

To find out more contact us: **01922 458 151** distribution@hellermanntyton.co.uk

www.hellermanntyton.co.uk