

ECS-TXO-32CSMV Clipped Sine Wave SMD TCXO MultiVolt™ capability of 1.7 ~ 3.465V. The 3.2 x 2.5 x 1.2 mm ceramic package is ideal for portable, wireless applications where stability is critical.

Request a Sample

OPERATING CONDITIONS / ELECTRICAL CHARACTERISTICS



- Clipped Sine Wave TCXO
- 3.2 x 2.5 mm Footprint
- MultiVolt™ (1.7 ~ 3.465V)
- PbFree/RoHS Compliant
- MSL 1
- Lead Finish Au
- Compatible with 1.8V, 2.5V or 3.3V Power Supply

Parameters	Conditions	ECS-TXO-32CSMV			Units
		MIN	TYP	MAX	
Frequency Range		10.000		52.000	MHz
Frequency Tolerance	@ +25°C ±2°C			±2.0	PPM
Frequency Stability	Vs. Temp (-40 ~ +85°C) BN Opt			±1.0	PPM
	Vs. Supply Change (±5%)			±0.2	PPM
	Vs. Load Change (±10%)			±0.2	PPM
	Vs. Aging 1 st Year			±1.0	PPM
Input Voltage	VDD	+1.7		+3.465	VDC
Current Consumption	10 ~ 26 MHz			2.0	mA
	26.1 ~ 52 MHz			2.5	mA
Output Level	Clipped Sine Wave	0.8			V p-p
Output Load		10KΩ//10 pF			
Start-up Time				2	mS
Phase Noise	@ 10 KHz Offset		-145		dBc/Hz
Operating Temperature	* N Option	-40		+85	°C
Storage Temperature		-40		+90	°C

Part Numbering Guide: Example ECS-TXO-32CSMV-260-BN-TR

ECS	Series	Frequency Abbreviations	Stability	Temperature	Packaging
ECS	TXO-32CSMV = Clipped Sine Wave TCXO	260 = 26.000 MHz	A= ±0.5 ppm B= ±1.0 ppm C= ±1.5 ppm D= ±2.0 ppm E= ±2.5 ppm	L= -10 ~ +70°C M= -20 ~ +70°C Y= -30 ~ +85°C N= -40 ~ +85°C	TR = Tape & Reel 1K/reel

Package Dimensions (mm)

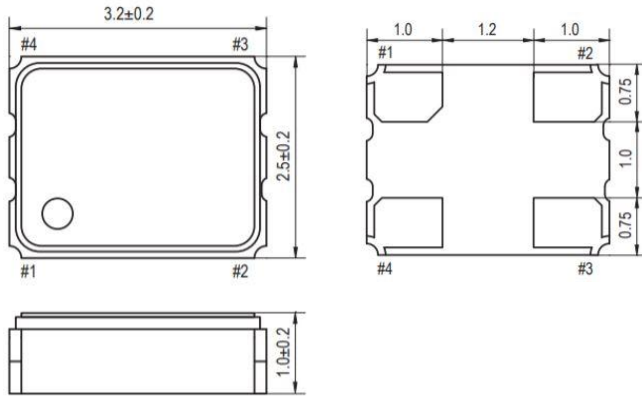

Figure 1) Top, Side, and Bottom views

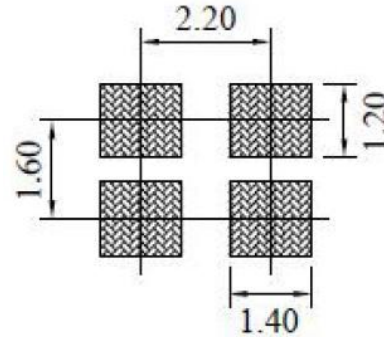

Figure 2) Land Pattern

Pin Connections	
#1	Ground
#2	Ground
#3	Output
#4	VDD

Developed Frequencies	
* Abbreviation	Frequency (MHz)
100	10.000
194.4	19.440
200	20.000
240	24.000
260	26.000
300	30.000
400	40.000

