

RoHS
Compliant



Features

- $V_{DS} = -40V$
- $I_D = -13A$
- $R_{DS(on)} < 15m\Omega @ V_{GS} = -10V$
- $R_{DS(on)} < 18m\Omega @ V_{GS} = -4.5V$
- High density cell design for ultra low $R_{ds(on)}$
- Fully characterized avalanche voltage and current
- Excellent package for good heat dissipation

Absolute Maximum Ratings (TA = 25°C unless otherwise noted)

Parameter	Symbol	Rating	Unit
Drain-Source Voltage	V_{DS}	-40	V
Gate-Source Voltage	V_{GS}	+20	
Continuous Drain Current	I_D	-13	A
Pulsed Drain Current	I_{DM}	-50	
Maximum Power Dissipation	P_D	2.5	W
Thermal Resistance, Junction- to-Ambient (Note 2)	$R_{\theta JA}$	50	°C/W
Junction Temperature	T_J	150	°C
Junction Storage Temperature Range	T_{stg}	-55 to 150	

Notes:

1. Repetitive Rating: Pulse width limited by maximum junction temperature.
2. Surface Mounted on FR4 Board, $t \leq 10$ sec.

Electrical Characteristics (TA = 25°C unless otherwise noted)

Parameter	Symbol	Test Conditions	Min	Typ	Max	Unit
Off Characteristics						
Drain-Source Breakdown Voltage	V_{DSS}	$I_D = -250\mu A, V_{GS} = 0V$	-40			V
Zero Gate Voltage Drain Current	I_{DSS}	$V_{DS} = -48V, V_{GS} = 0V$			-1	μA
Gate-Body leakage current	I_{GSS}	$V_{DS} = 0V, V_{GS} = \pm 20V$			± 100	nA
On Characteristics (Note 3)						
Gate Threshold Voltage	$V_{GS(th)}$	$V_{DS} = V_{GS}, I_D = -250\mu A$	-1.3	-2	-2.5	V
Static Drain-Source On-Resistance	$R_{DS(on)}$	$V_{GS} = -10V, I_D = -12A$		12	15	$m\Omega$
Forward Transconductance	g_{FS}	$V_{DS} = -15V, I_D = -10A$	35			S
Dynamic Characteristics (Note 4)						
Input Capacitance	C_{iss}	$V_{GS} = 0V, V_{DS} = -30V, f = 1MHz$		2800		pF
Output Capacitance	C_{oss}			320		
Reverse Transfer Capacitance	C_{rss}			220		

Newark.com/multicomp-pro
Farnell.com/multicomp-pro
sg.element14.com/b/multicomp-pro

Parameter	Symbol	Test Conditions	Min	Typ	Max	Unit
Switching Characteristics (Note 4)						
Turn-On Delay Time	$t_{d(on)}$	$V_{DS}=-20V, R_L = 2\Omega$ $V_{GS}=-10V, R_{GEN}=6\Omega$		11		nS
Turn-On Rise Time	t_r			75		
Turn-Off Delay Time	$t_{d(off)}$			89		
Turn-Off Fall Time	t_f			35		
Total Gate Charge	Q_g	$V_{DS}=-20V, I_D=-12A, V_{GS}=-10A$		40		nC
Gate Source Charge	Q_{gs}			6		
Gate Drain Charge	Q_{gd}			12		
Drain-Source Diode Characteristics Note 3)						
Diode Forward Voltage	V_{SD}	$I_{SD}=-12A, V_{GS}=0V$			-1.2	V
Diode Forward Current	I_S				-13	A

Notes:

1. Pulse Test: Pulse Width $\leq 300\mu s$, Duty Cycle $\leq 2\%$.
2. Guaranteed by design, not subject to production

Typical Characteristics

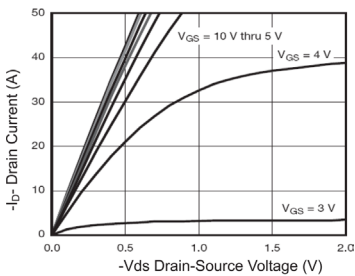

Figure 1 Output Characteristics

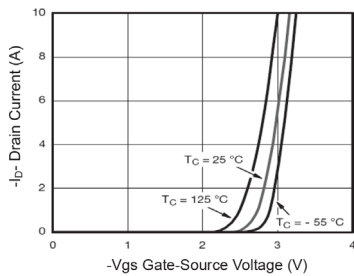

Figure 2 Transfer Characteristics

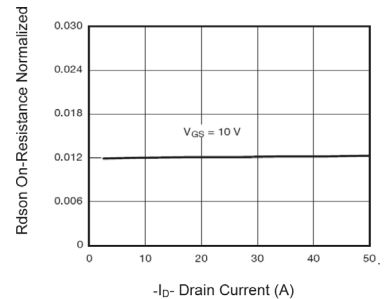

Figure 3 Rdson- Drain Current

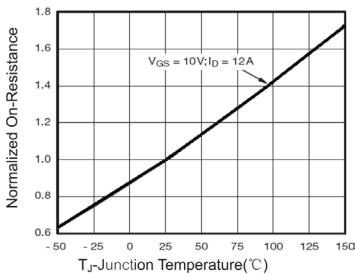

Figure 4 Rdson-Junction Temperature

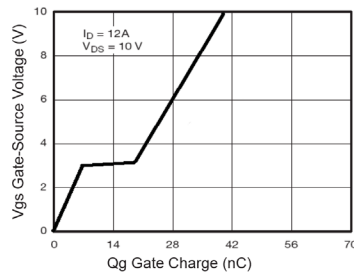

Figure 5 Gate Charge

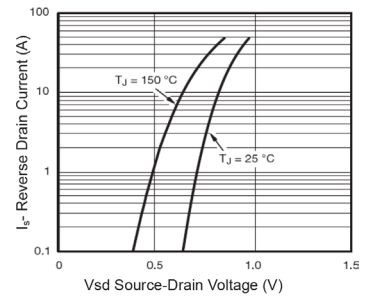
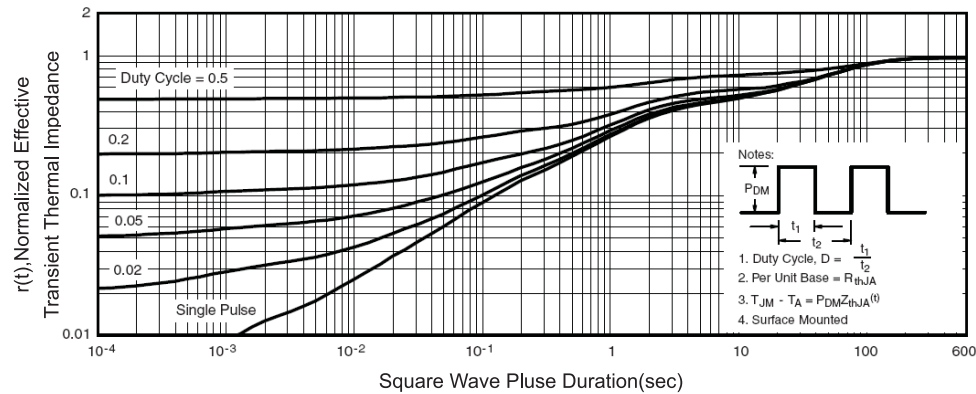
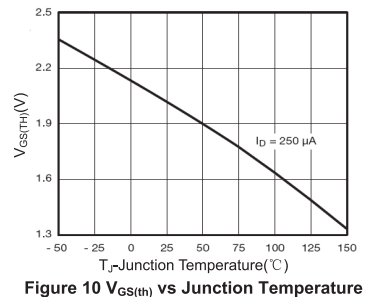
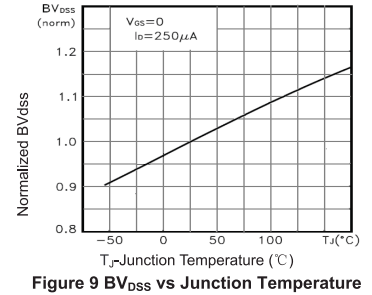
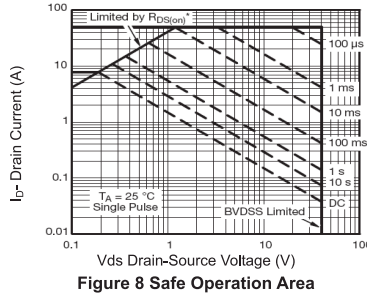
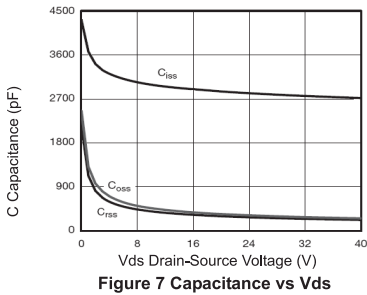

Figure 6 Source- Drain Diode Forward

Typical Characteristics



P Channel MOSFET

Diagram

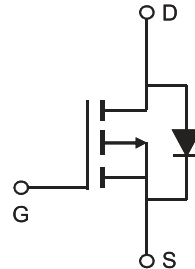
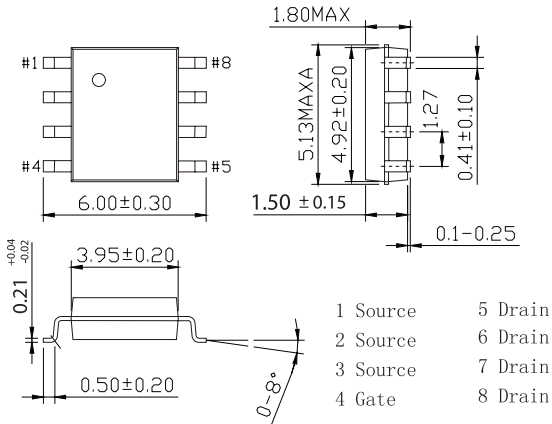

Part Number Table

Description	Part Number
P Channel MOSFET, 13A, 40V, SOP8	2KJ7008

Dimensions : Millimetres

Important Notice : This data sheet and its contents (the "Information") belong to the members of the AVNET group of companies (the "Group") or are licensed to it. No licence is granted for the use of it other than for information purposes in connection with the products to which it relates. No licence of any intellectual property rights is granted. The Information is subject to change without notice and replaces all data sheets previously supplied. The Information supplied is believed to be accurate but the Group assumes no responsibility for its accuracy or completeness, any error in or omission from it or for any use made of it. Users of this data sheet should check for themselves the Information and the suitability of the products for their purpose and not make any assumptions based on information included or omitted. Liability for loss or damage resulting from any reliance on the Information or use of it (including liability resulting from negligence or where the Group was aware of the possibility of such loss or damage arising) is excluded. This will not operate to limit or restrict the Group's liability for death or personal injury resulting from its negligence. Multicomp Pro is the registered trademark of Premier Farnell Limited 2019.

Newark.com/multicomp-pro
 Farnell.com/multicomp-pro
 sg.element14.com/b/multicomp-pro