

# Safety Controllers



## Safety Controller Highlights

- Intuitive icon-based drag-and-drop configuration via free PC software
- 10 input, 26 input, and expandable models available
- Communicates over industrial Ethernet
  - 80 virtual non-safe inputs
  - 256 virtual non-safe status outputs
- EtherCAT expansion module is daisy chain and line topology ready with two RJ45 connectors
- Export tag feature for easy PLC setup and integration
- Live view and configure controller via network access feature

# Safety Relays and Controllers

Industrial safety controllers and relays provide an interface between safety devices and the machines and processes those devices monitor for a complete and easy-to-use safety control solution.

## Expandable Safety Controller



- Expandable for Complex Safety applications where 3 or more safety relays are typically used
- PC Configurable: Flexible and easy-to-use
  - Network Accessible: Configure and Live View via an Ethernet connection (Ethernet enabled XS26 and SC26 models only)
  - Safe Devices: Up to 394 with ISD
  - Safety Inputs: 26 (base unit) up to 154
  - Independently controlled Safety Outputs: up to 68, 0.5A to 6A each
  - Convertible Safety Inputs: 8 (Base Unit) up to 40
  - LCD Display for easy troubleshooting
  - Industrial Ethernet
  - In-Series Diagnostic (ISD) provides detailed status and performance data

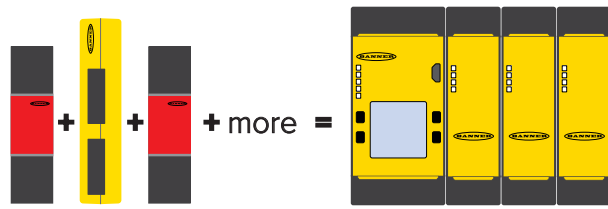

## Hybrid Safety Controller plus 2 Safety Relays

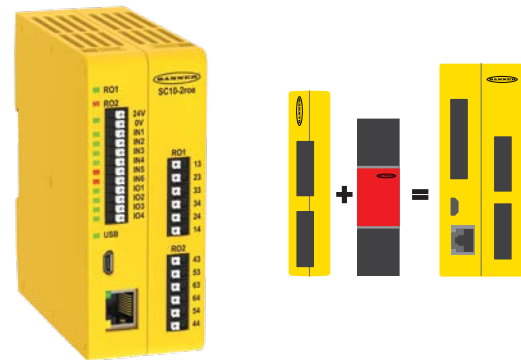

- Flexible and cost effective solution for machines typically using 2 Safety Relays
- PC Configurable: Flexible and easy-to-use
  - Safe Devices: Up to 70 with ISD
  - Safety Inputs: up to 14 using Automatic Terminal Optimization (ATO)
  - Independently controlled Safety Outputs: 2, 6A each
  - Convertible Safety Inputs: 4
  - Terminal LEDs for easy troubleshooting
  - Industrial Ethernet

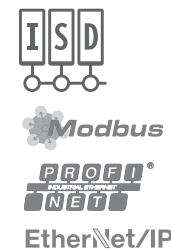

## Safety Relays



- Cost effective for simple safety circuits
- Pre-set Functionality: Configuration not required
  - Safety Inputs: 1
  - Independently controlled Safety Outputs: 1, 4 to 7A

### Configurable Safety Controllers

### Pre-configured Safety Relay Modules



	XS26	SC26	SC10	SR	IM	ES	UM	GM	SM	AT Two-Hand	MMD
# of Input Terminals	up to 154*	up to 26	10*	1	1	1	1	1	1	2 STB	2
# of Safe Devices when using ISD	394	1	70	1	1	1	1	1	1	2	1
Independently Controlled Safe Outputs	up to 68*	2	2	1	1	1	1	1	1	1	1
Max. Safety Output Rating	0.5A, 6A* ea.	0.5A ea.	6A ea.	6A	6A	7A	7A	6A	6A	6A	6A
In-Series Diagnostics (ISD)	✓		✓								
Modbus TCP/IP	✓	✓	✓								
PROFIBUS DP	✓	✓	✓								
EtherNet/IP	✓	✓	✓								
EtherCAT	✓										
Network Access and View	✓	✓									
E-Stop	✓	✓	✓			✓	✓				✓
Rope Pull	✓	✓	✓			✓	✓				✓
Light Curtain/Scanner	✓	✓	✓				✓				✓
Light Curtain/Scanner with EDM	✓	✓	✓	✓	✓		✓				✓
Gate Switch (Complimentary Outputs ie. NC/NO)	✓	✓	✓					✓			
Gate Switch (Similar Outputs ie. NC/NC)	✓	✓	✓			✓	✓				✓
Safety Mat Monitoring	✓	✓	✓						✓		
Two-Hand Control	✓	✓	✓							✓	
Muting	✓	✓	✓								✓
ON/OFF Delay	✓	✓	✓								

NOTE: Up to Cat. 4 PL e. per EN ISO 13849-1; SIL 3 per IEC 61508 and IEC 62061. See [www.bannerengineering.com](http://www.bannerengineering.com) for additional information.

\*Expandable input and output modules available

# Build System and Select Equipment

Start using the free software today. Go to [bannerengineering.com/safetycontrol](http://bannerengineering.com/safetycontrol)

The feature-rich SC10 and SC/XS26 safety controller software provides a seamless user interface for setting up and managing safety systems. The software features an intuitive icon-based, drag-and-drop user interface to reduce the learning curve and speed up commissioning.

- Complex configurations made easy
- Simulate configurations before implementation
- Auto configure industrial Ethernet for remote monitoring and diagnostics

## 1. Choose controller



## 2. Equipment view

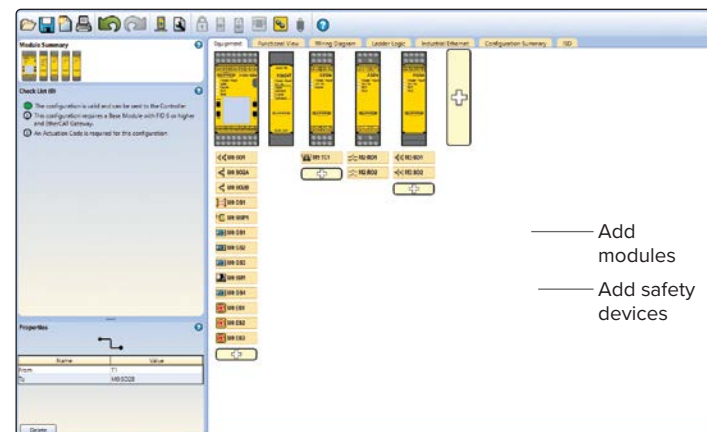

## 3. Add safety devices



## 4. Select safety device properties

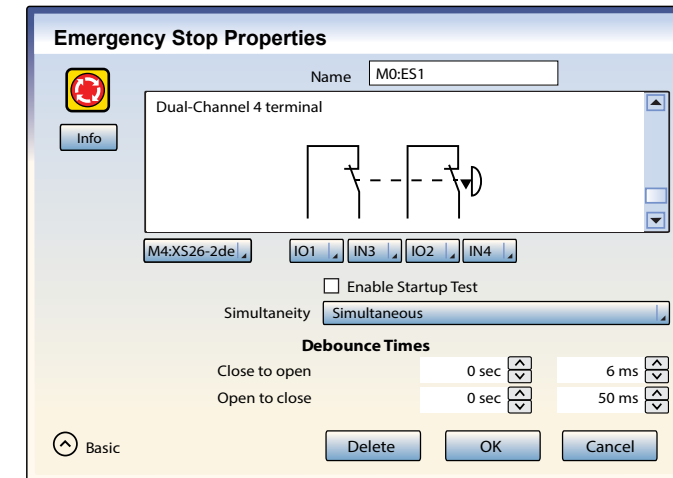

## 5. Add virtual non-safety inputs



## 6. Configure your system in minutes

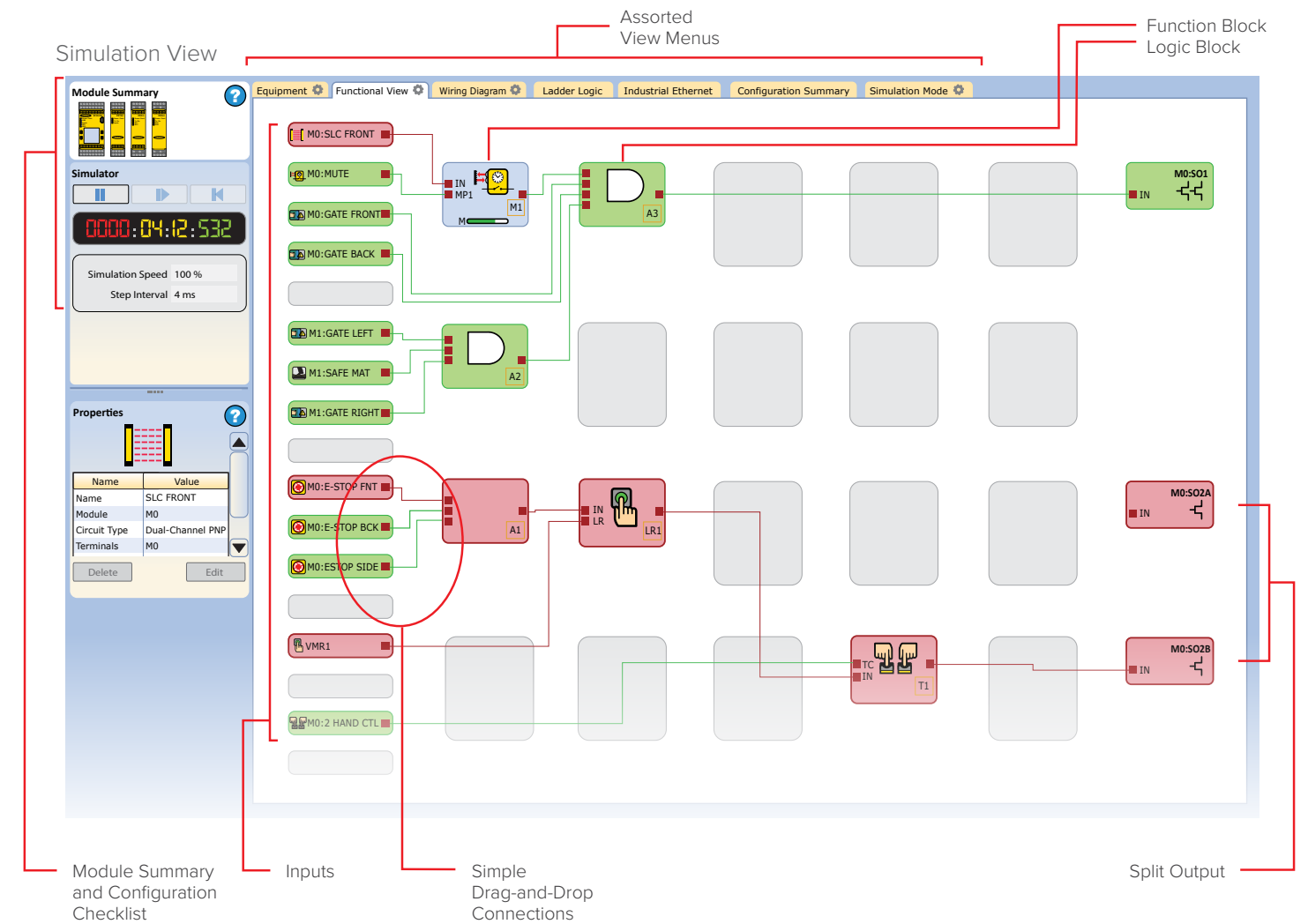

## Wiring diagram in live mode

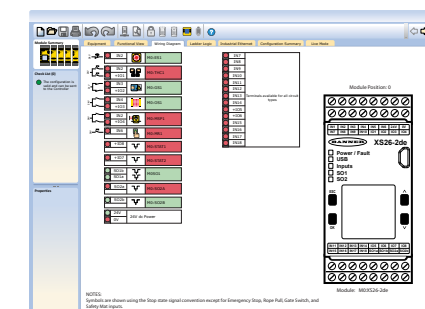

## Ladder logic

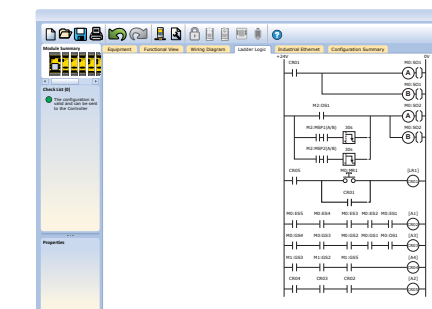

## Industrial network integration

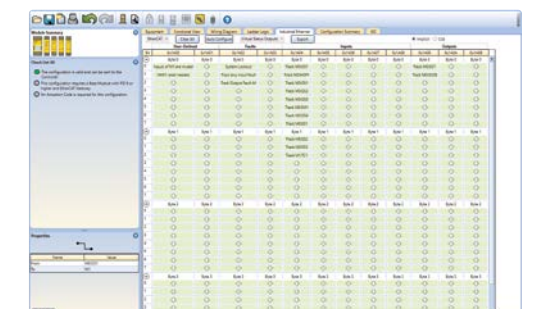

# XS26 Expandable Safety Controller

- Optional display screen allows local diagnostics for efficient troubleshooting
- Up to eight expansion I/O modules can be added as automation requirements grow or change
- Choose from six expansion module models with a variety of safety inputs, solid-state safety outputs and safety relay outputs
- Controller and input modules allow safety inputs to be converted to status outputs for efficient terminal use
- Fast programming and swapout using the SC-XM3 memory card (see next page)
- Network accessible: configure and live view via an Ethernet connection (Ethernet enabled XS26 and SC26 models only)

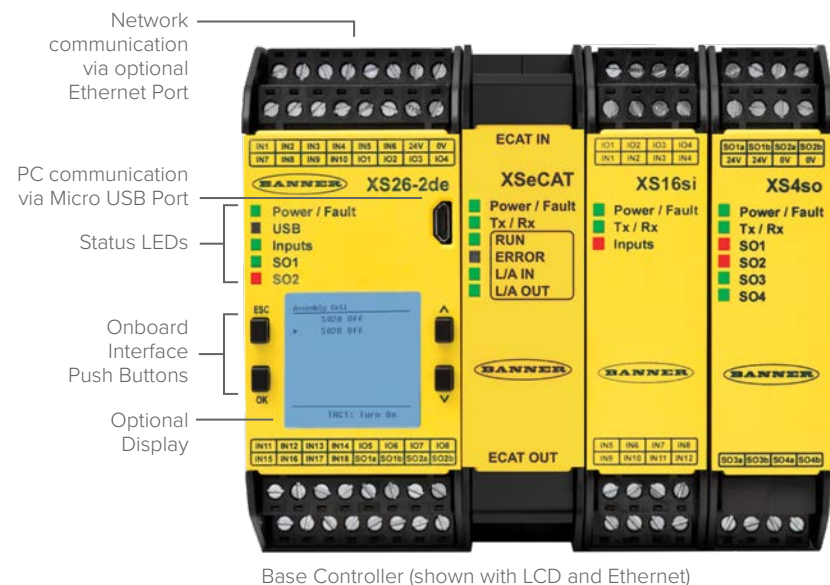

## XS26 Safety Controller

- Base Controller allows eight of the 26 inputs to be configured as outputs for efficient terminal use
- Two independent pairs of safe outputs at 0.5A each
- In-Series Diagnostic (ISD) provides detailed status and performance data



## SC26 Safety Controller

- Base Controller allows eight of the 26 inputs to be configured as outputs for efficient terminal use
- Two independent pairs of safe outputs at 0.5A each
- Models available with optional Ethernet and display

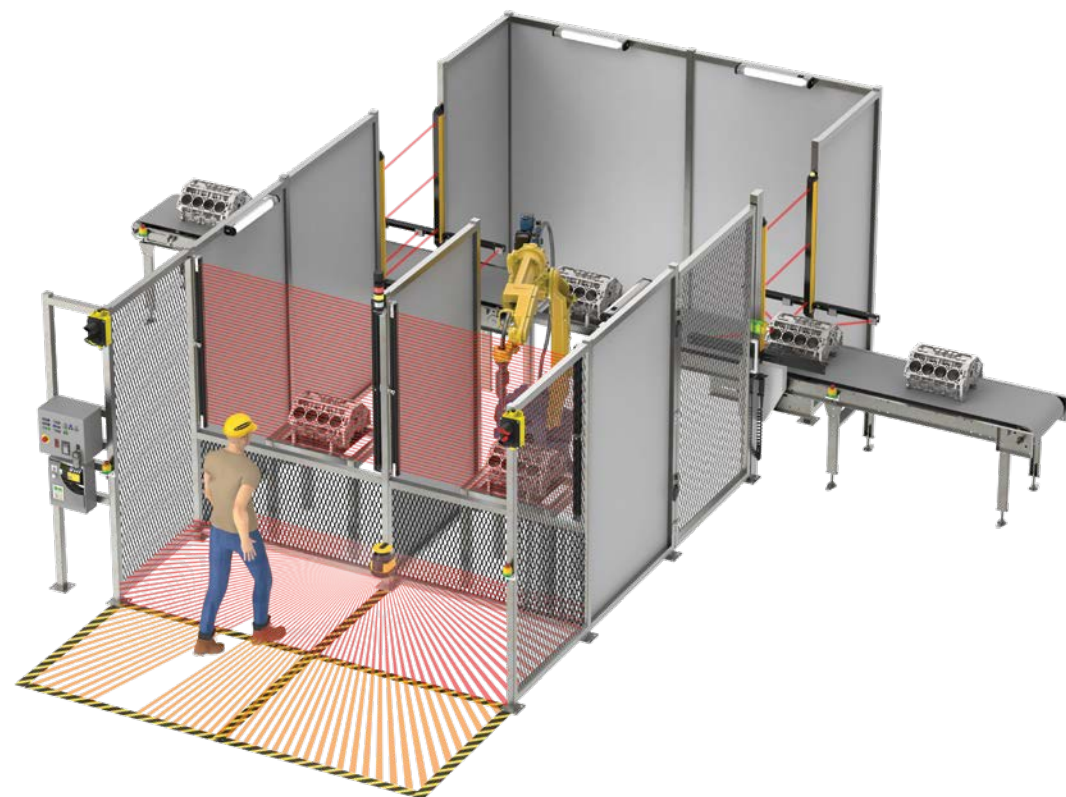

# SC10 Safety Controller

## Automatic Terminal Optimization (ATO)

Allows for an increase from 10 to 14 inputs

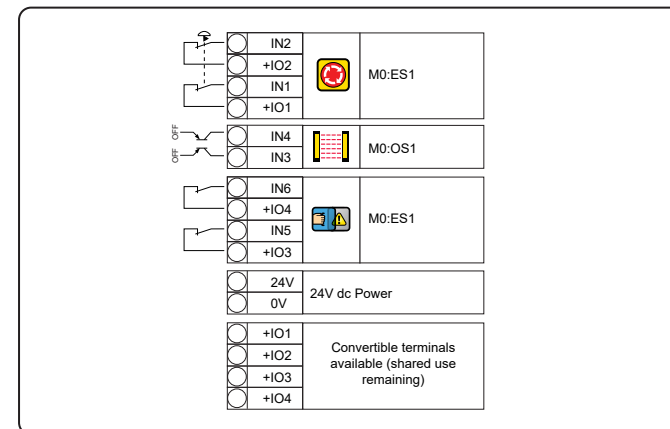

Wire Diagram View for 10 Inputs without ATO

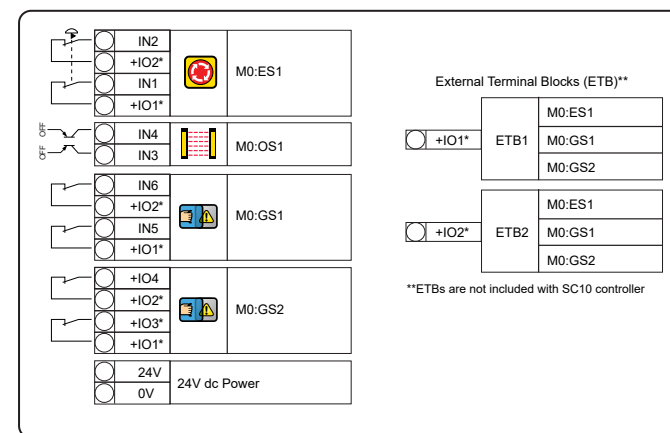

Wire Diagram View for 14 Inputs with ATO

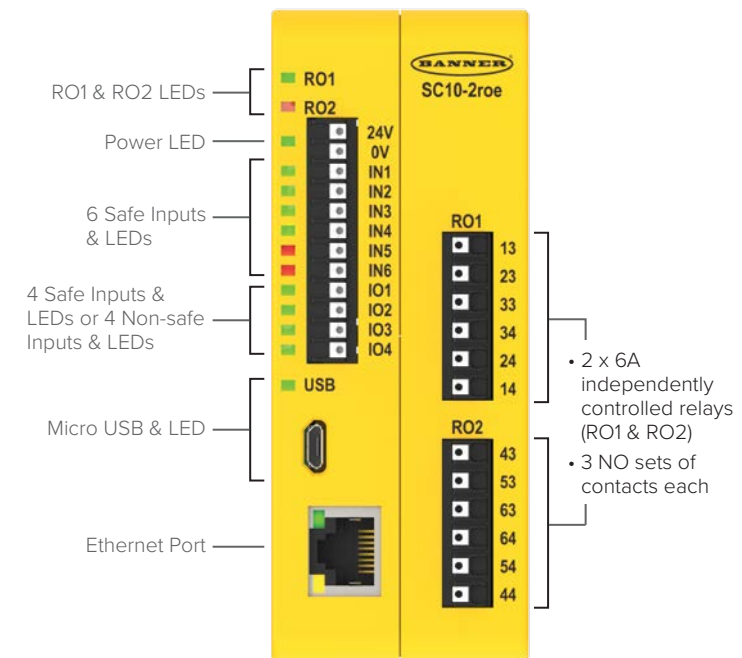

Store SC-XM3 memory card directly on SC10 or XS26

## SC-XM3

Fast Programming and Swapout

- Backup copy of configuration, password, network settings
- Download configuration without a PC; Save time during panel build
- Fast swapout to minimize downtime at swapout



In-Series Diagnostics (ISD) makes it easy to access diagnostic data from devices in a safety system without special equipment or designated cabling. Users can troubleshoot machine safety systems, prevent system faults, and reduce equipment downtime.

This innovative, next generation technology is exclusive to safety devices from Banner Engineering. For more information go to [www.bannerengineering.com/isd](http://www.bannerengineering.com/isd)



Model*	Description	Industrial Ethernet	Inputs/Convertible	Independently Controlled Safe Outputs	Max. Safety Output Rating	Model*	Description	Industrial Ethernet	Inputs/Convertible	Independently Controlled Safe Outputs	Max. Safety Output Rating
XS26-2d XS26-2de	Base Controller with LCD	✓	26/8	2	0.5A PNP @24 V DC	XS4so	Safety Output Module		–	2	0.5A PNP @24 V DC
XS26-2 XS26-2e	Base Controller	✓	26/8	2	0.5A PNP @24 V DC	XS1ro	Safety Relay Output Module		–	1	6A; 2 NO, 1 NC aux
XS26-ISDd	Base Controller 	✓	26/8	2	0.5A PNP @24 V DC	XS2ro	Safety Relay Output Module		–	2	6A; 2 NO, 1 NC aux
XSeCAT	EtherCAT Expansion Module	EtherCAT	–	–	–	SC26-2d SC26-2de	Base Controller with LCD	✓	26/8	2	0.5A PNP @24 V DC
XS8si	Safety Input Module		8/2	–	–	SC26-2 SC26-2e	Base Controller	✓	26/8	2	0.5A PNP @24 V DC
XS16si	Safety Input Module		16/4	–	–	SC10-2roe	Base Controller 	✓	10/4	2	6A; 3 NO
XS2so	Safety Output Module		–	1	0.75A PNP @24 V DC						

\*Models operate at 24 V DC +/- 20%.

## Specifications



## Accessories



SC-USB2  
USB Cable



SC-XM3  
Memory Card



SC-XMP2  
SC-XM2/3 Configuration Tool

Additional accessories are available at [bannerengineering.com](http://bannerengineering.com)

Start using the free software today. Go to [bannerengineering.com/safetycontroller](http://bannerengineering.com/safetycontroller)



Banner Engineering Corp.

9714 10th Avenue North • Minneapolis, MN 55441 • 1-888-373-6767 • [www.bannerengineering.com](http://www.bannerengineering.com)