



# Film Capacitors - Power Electronic Capacitors

## Power Electronic Capacitors

**Series/Type:** MKP DC LSI  
**Ordering code:** B2563xB\*  
Date: April 2026  
Version: 2

**Construction and general data**

<b>Characteristics</b>	
Capacitance tolerance	K: $\pm 10\%$
Dielectric dissipation factor ( $\tan \delta_o$ )	$2 \cdot 10^{-4}$
Service life expectancy $t_{LD (co)}$	100000 h at $T_{hs} +70\text{ °C}$ and $V_{RDC}$ Up to 200 000 h (Considering deratings in voltage and/or temperature upon request)
Expected Fit rate $\alpha_{FQ (co)}$	100 Fit at $V_{RDC}$ and $70\text{ °C}$
Storage temperature $T_{stg}$	$-40 \dots +85\text{ °C}$
Minimum temperature $T_{op,min.}$	$-40\text{ °C}$
Maximum temperature $T_{op,max.}$	$+85\text{ °C}$
Maximum hotspot temperature $T_{hs}$	$+85\text{ °C}$
Climatic category	40/85/56
Maximum altitude	2000 m above sea level (derating curves for altitudes higher than 2000 m available upon request)
Safety device	No internal protection
Clearance distance between terminals	28 mm (typical value)
Creepage distance between terminals	33.5 mm (typical value)

<b>Test data</b>	
Voltage between terminals $V_{TT}$	$1.5 \cdot V_{RDC}$ , 10 s
Dissipation factor $\tan \delta$ (100 Hz)	$\leq 1.0 \cdot 10^{-3}$
Life test	According to IEC 61071-2017
Cooling	Naturally air-cooled (or forced air cooling)
Degree of protection	IP00 (indoor mounting)

<b>Design data</b>	
Resin filling	Non PCB, hard polyurethane (dry type)
Mounting	Lateral brackets
Max. torque terminal	Male M8: 8 Nm Female M5: 2.5 Nm

<b>Reference standards</b>	
IEC 61071-2017, GB/T 17702-2021	
RoHS and CE compliance	
UL 94 V0	

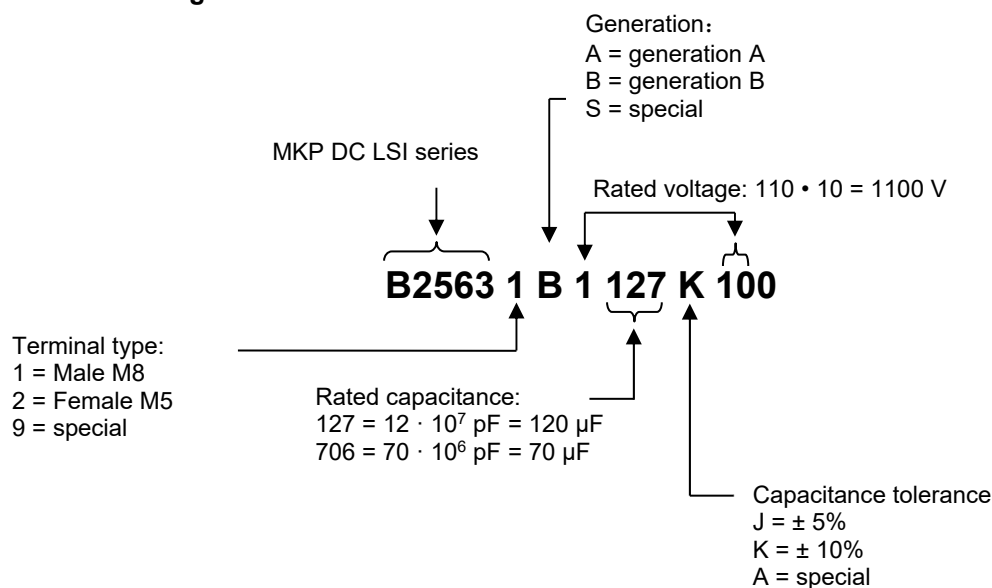
**Structure of ordering code**

**Label information**

**B25632B1127K100**

 120 $\mu$ F                       $\pm 10\%$ 
 $V_{\text{RDC}} = 1100\text{V}$ 

-40...+85°C                      IEC 61071

SH-No PCB                      Dry Type

Max. torque of terminals: 2.5Nm

Discharge before handling

Made by TDK                      10 Z 2022

**The label explanation is following:**
**10 Z 2022:** Production in TDK Electronics Zhuhai factory **2022** year, calendar week **10**;

Bar code consists of lot number and serial number:

 Lot number: 9 digits (ex.: **905887304**)

 Serial number: 3 digits (ex.: **001**)

Dimensional drawings

Figure 1: B25631B  
- Male M8 terminals

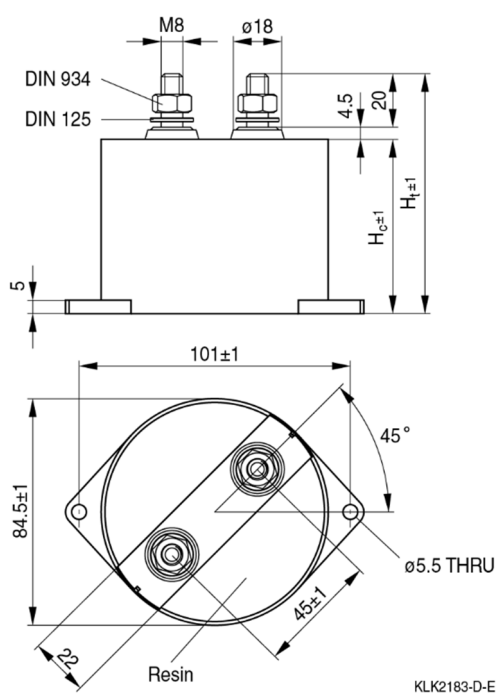
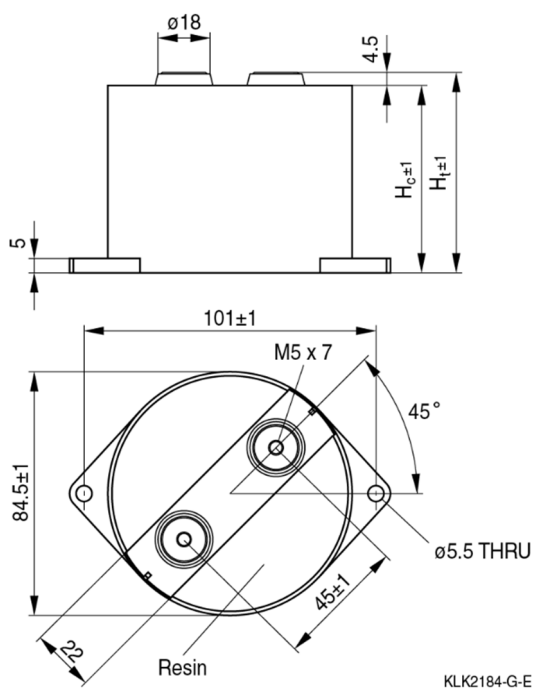

Figure 2: B25632B  
- Female M5 terminals



## Terms and characteristics

The following definitions apply to power capacitors according to IEC 61071.

### Rated capacitance $C_R$

Nominal value of the capacitance at 20 °C and measuring frequency of 100 Hz.

### Rated DC voltage $V_{RDC}$

Maximum operating peak voltage of either polarity but of a non-reversing type wave form, for which the capacitor has been designed, for continuous operation.

### Ripple voltage $V_{ripple}$

Peak-to-peak alternating component of the unidirectional voltage.

This value must not exceed  $0.28 \cdot V_{RDC}$

### Maximum surge voltage $V_s$

Peak voltage induced by a switching or any other disturbance of the system which is allowed for a limited number of times and short period.

### Insulation voltage $V_i$

RMS rated value of the insulation voltage of capacitive elements and terminals to case or earth. When it is not specified in the product data sheet, the insulation voltage is at least:

$$V_i = \frac{V_{RDC}}{\sqrt{2}}$$

### AC voltage test between terminals and case $V_{TC}$

Units having all terminals insulated from the container shall be subjected for 10 s to a voltage applied between the terminals (joined together) and the container.

### Maximum rate of voltage rise $(dv/dt)_{max}$

Maximum permissible repetitive rate of voltage rise of the operational voltage.

### Maximum current $I_{max}$

Maximum RMS current for continuous operation for the given frequency range and for the maximum ripple voltage. Please provide Frequency Spectrum of RMS current to your sales contact.

### Maximum peak current $\hat{I}$

Maximum permissible repetitive current amplitude during continuous operation.

Maximum peak current ( $\hat{I}$ ) and maximum rate of voltage rise  $(dv/dt)_{max}$  on a capacitor are related as follows:

$$\hat{I} = C \cdot (dv/dt)_{max}$$

### Maximum surge current $\hat{I}_s$

Admissible peak current induced by a switching or any other disturbance of the system which is allowed for a limited number of times and short period.

$$\hat{I}_s = C \cdot (dv/dt)_s$$

**Ambient temperature  $T_A$** 

Temperature of the surrounding air, measured at 10 cm distance and 2/3 of the case height of the capacitor.

**Lowest operating temperature  $T_{op,min}$** 

Lowest permitted ambient temperature at which a capacitor may be energized.

**Maximum operating temperature  $T_{op,max}$** 

Highest permitted capacitor temperature during operation, i.e. temperature at the hottest point of the case.

**Hot-spot temperature  $T_{hs}$** 

Temperature zone inside of the capacitor at hottest spot.

$$T_{hs} = T_A + I_{RMS}^2 \cdot ESR \cdot R_{th}$$

**Tangent of the loss angle of a capacitor  $\tan \delta$** 

Ratio between the equivalent series resistance and the capacitive reactance of a capacitor at a specified sinusoidal alternating voltage, frequency and temperature.

**Series resistance  $R_s$** 

The sum of all ohmic resistances occurring inside the capacitor.

**ESR**

ESR (Equivalent Series Resistance) which if connected in series with an ideal capacitor of capacitance value equal to that of the capacitor in question, would have a power loss equal to active power dissipated in that capacitor under specified operating conditions.

$$ESR = \frac{\tan \delta}{\omega \cdot C} = R_s + \frac{\tan \delta_0}{\omega \cdot C}$$

**Thermal resistance  $R_{th}$** 

The thermal resistance indicates by how many degrees the capacitor temperature at the hot spot rises in relation to the dissipation losses.

**Maximum power loss  $P_{max}$** 

Maximum permissible power dissipation for the capacitor's operation.

$$P_{max} = \frac{T_{hs} - T_A}{R_{th}}$$

**Self inductance  $L_{self}$** 

The sum of all inductive elements which are contained in a capacitor.

**Resonance frequency  $f_r$** 

The lowest frequency at which the impedance of the capacitor becomes minimum.

$$f_r = \frac{1}{2\pi \cdot \sqrt{L_{self} \cdot C_R}}$$

V <sub>RDC</sub>	C <sub>R</sub>	I <sub>max</sub> <sup>1</sup>	I <sub>̂</sub>	I <sub>s</sub>	ESR <sup>2</sup>	L <sub>self</sub>	f <sub>r</sub>	R <sub>th</sub>	H <sub>c</sub>	H <sub>t</sub>	Weight <sup>3</sup>	Ordering code
	μF	A	kA	kA	mΩ	nH	kHz	K/W	mm	mm	kg	
600	200	55	2.9	8.7	0.9	30	65	6.8	50	74.5	0.4	B25631B0207K600
	300	60	2.9	8.7	1.2	35	49	4.5	65	89.5	0.49	B25631B0307K600
	300	60	2.9	8.7	1.2	35	49	4.5	65	69.5	0.46	B25632B0307K600
700	150	55	2.5	7.5	0.9	30	75	6.8	50	74.5	0.4	B25631B0157K700
	220	60	2.4	7.3	1.2	35	57	4.5	65	89.5	0.49	B25631B0227K700
800	120	55	2.2	6.7	1.0	30	84	6.8	50	74.5	0.4	B25631B0127K800
	180	60	2.2	6.7	1.3	35	63	4.5	65	89.5	0.49	B25631B0187K800
	180	60	2.2	6.7	1.3	35	63	4.5	65	69.5	0.46	B25632B0187K800
900	100	55	2.7	8.1	1.0	30	92	6.8	50	74.5	0.4	B25631B0107K900
	150	60	2.5	7.5	1.3	35	69	4.5	65	89.5	0.49	B25631B0157K900
1100	80	50	2.3	6.9	1.1	30	103	6.8	50	74.5	0.4	B25631B1806K100
	120	55	2.2	6.6	1.4	35	78	4.5	65	89.5	0.49	B25631B1127K100
	120	55	2.2	6.6	1.4	35	78	4.5	65	69.5	0.46	B25632B1127K100
1200	60	50	2.1	6.3	1.3	30	119	6.8	50	74.5	0.4	B25631B1606K200
	95	55	2.2	6.6	1.6	35	87	4.5	65	89.5	0.49	B25631B1956K200
1300	50	50	2.0	6.0	1.4	30	130	6.8	50	74.5	0.4	B25631B1506K300
	80	55	2.0	6.0	1.7	35	95	4.5	65	89.5	0.49	B25631B1806K300
1400	45	50	1.7	5.1	1.5	30	137	6.8	50	74.5	0.4	B25631B1456K400*
	70	55	1.8	5.4	1.7	35	102	4.5	65	89.5	0.49	B25631B1706K400*
1500	40	45	1.6	4.8	1.6	30	145	6.8	50	74.5	0.4	B25631B1406K500*
	60	50	1.6	4.8	1.9	35	110	4.5	65	89.5	0.49	B25631B1606K500*
1600	35	45	1.5	4.5	1.7	30	155	6.8	50	74.5	0.4	B25631B1356K600*
	55	50	1.6	4.8	2.3	35	115	4.5	65	89.5	0.49	B25631B1556K600*
2000	20	45	1.2	3.6	1.8	30	205	6.8	50	74.5	0.4	B25631B2206K000*
	30	50	1.3	3.9	2.5	35	155	4.5	65	89.5	0.49	B25631B2306K000*

<sup>1</sup> I<sub>max</sub> at ambient temperature 55 °C

<sup>2</sup> ESR at 1 kHz (typical value)

<sup>3</sup> Weight is typical value

Other configurations and capacitance tolerances available upon request

**\* This ording code is affected by "Dual Use" regulations according to Export Control law. Deliveries of such products are subject to prior approval by Export Control authorities based on customer declarations. The delivery to certain countries might be restricted.**

**Service life expectancy**

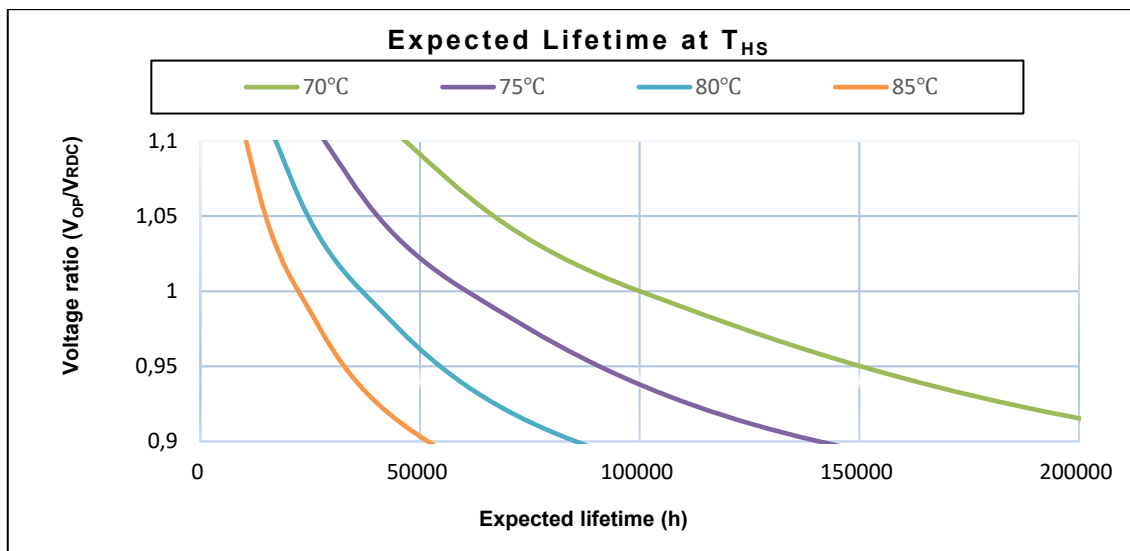

Service life  $t_{LD}$  at different hot spot temperature ( $T_{hs}$ ) and  $V_{OP}$

Failure criteria is capacitance drop higher than 3%.

Lifetime estimations are typical theoretical values derived from lifetime tests based on TDK internal standards or mutually agreed test methods and are intended for guidance purposes only. The useful life does not constitute a warranty of any kind or a prolongation of the agreed warranty period.

**Expected failure rate**

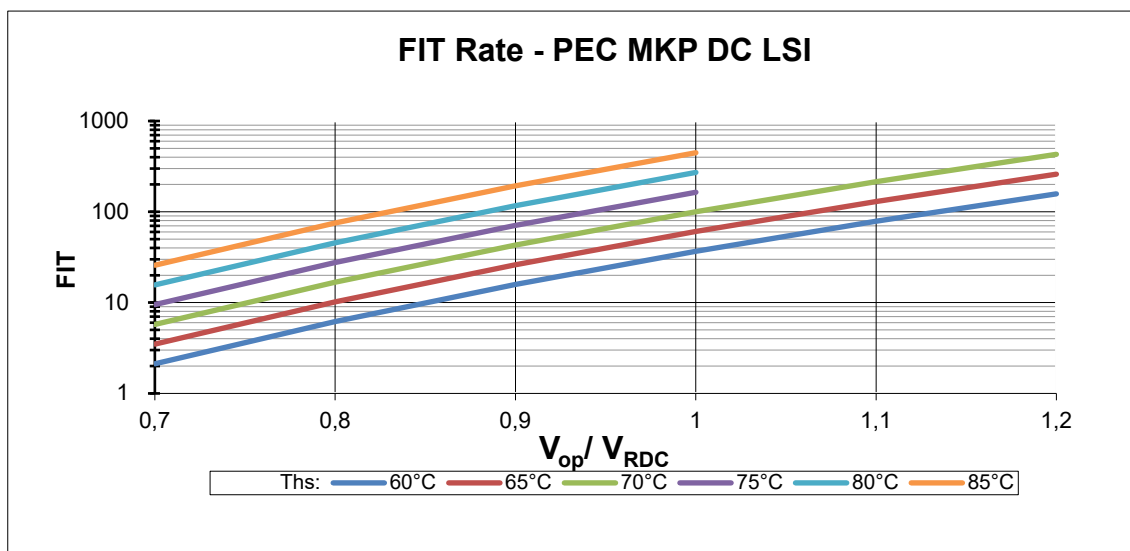

Expected fit rate at different hot spot temperatures ( $T_{hs}$ ) and voltage  $V_{RDC}$

The FIT (Failure In Time) of a component is defined as the number of expected failures in  $10^9$  hours of operation.

The FIT rate is calculated on the basis of the number of components operating in the field and the estimated hours of operation. All the reports of failures are taken into consideration for this calculation, which is updated every year.

The other values in the graph are given as indication and calculated based on acceleration factors.

### Display of ordering codes for TDK Electronics products

The ordering code for one and the same product can be represented differently in data sheets, data books, other publications, on the company website, or in order-related documents such as shipping notes, order confirmations and product labels. **The varying representations of the ordering codes are due to different processes employed and do not affect the specifications of the respective products.** Detailed information can be found on the Internet under [www.tdk-electronics.tdk.com/orderingcodes](http://www.tdk-electronics.tdk.com/orderingcodes).

## Cautions and warnings

- In case of dents of more than 1 mm depth or any other mechanical damage, capacitors must not be used at all.
- The energy stored in capacitors may be lethal. To prevent any chance of shock, discharge and short-circuit the capacitor before handling.
- Failure to follow cautions may result, worst case, in premature failures, bursting and fire.
- Protect the capacitor properly against over current and short circuit.
- TDK Electronics is not responsible for any kind of possible damages to persons or things due to improper installation and application of capacitors for power electronics.

### General safety notes for installation and operation

Electrical or mechanical misapplication of capacitors may be hazardous. Personal injury or property damage may result from bursting of the capacitor or from expulsion melted material due to mechanical disruption of the capacitor.

- Observe appropriate safety precautions during operation (self-recharging phenomena and the high energy contained in capacitors).
- Handle capacitors carefully, because they may still be charged even after disconnection.
- The terminals of capacitors, connected bus bars and cables as well as other devices may also be energized.
- Follow good engineering practice.

### Thermal load

After installation of the capacitor it is necessary to verify that maximum hot-spot temperature is not exceeded at extreme service conditions.

### Installation

Capacitors must be installed in a cool and well ventilated place, and not close to objects that radiate heat, or in the direct sunlight. Within high-power inverter systems the capacitors usually produce the smallest portion of the total losses, and the permissible operating temperatures are low compared to power semiconductors, reactors and resistors. So, the distance between capacitor and heating sources must be large enough to avoid the capacitor overheating. In case of space constraint to make the best possible use of capacitors, technically and economically, it is advisable to supply forced cooling air.

### Mechanical protection

The capacitor has to be installed in a way that mechanical damages and dents in the case are avoided.

### Connecting

Ensure firm fixing of terminals, fixing torque to be applied as per individual specification. In any case, the maximum specified terminal current may not be exceeded. Please refer to the technical data of the specific series.

### Maintenance

Disregarding the following measures may result in severe operation failures, bursting and fire:

- Check tightness of the connections/terminals periodically, two weeks after installation at the latest, and then once every 6 months.
- Clean the terminals/bushings periodically to avoid short circuits due dust or other contamination.
- Take current reading twice a year and compare with nominal current. Use a harmonic analyser or true effective RMS-meter.
- In case of a current above the nominal current check your application for modification.
- Check the temperature of energized capacitors. In case of excessive temperature of individual capacitors, it is recommended to replace this capacitor, as this could be an indication for loss factor increase, which is a sign for reaching end of life.
- When power capacitors are used, suitable measures must always be taken to eliminate possible danger to humans, animals and property both during operation and when a failure occurs. This applies to capacitors both with and without protective devices. Regular inspection and maintenance by a competent person is therefore essential.

#### Storage and operating conditions

Do not use or store capacitors in corrosive atmosphere, especially where chloride gas, sulfide gas, acid, alkali, salt or the like are present. In dusty environments regular maintenance and cleaning especially of the terminals is required to avoid conductive path between phases and/or phases and ground.

#### Service life expectancy

Electrical components do not have an unlimited service life expectancy; this applies to self-healing capacitors, too. The maximum service life expectancy may vary depending on the application the capacitor is used in.

#### Handling

Discharge and short circuit the capacitor before handling! When handling the capacitor, do not take the capacitor from the terminal. This can cause accident in case the capacitor is charged, terminal break and capacitance loss due to capacitor is heavy.

## Important notes

The following applies to all products named in this publication:

1. Some parts of this publication contain **statements about the suitability of our products for certain areas of application**. These statements are based on our knowledge of typical requirements that are often placed on our products in the areas of application concerned. We nevertheless expressly point out **that such statements cannot be regarded as binding statements about the suitability of our products for a particular customer application**. As a rule we are either unfamiliar with individual customer applications or less familiar with them than the customers themselves. For these reasons, it is always ultimately incumbent on the customer to check and decide whether a product with the properties described in the product specification is suitable for use in a particular customer application.
2. We also point out that **in individual cases, a malfunction of electronic components or failure before the end of their usual service life cannot be completely ruled out in the current state of the art, even if they are operated as specified**. In customer applications requiring a very high level of operational safety and especially in customer applications in which the malfunction or failure of an electronic component could endanger human life or health (e.g. in accident prevention or life-saving systems), it must therefore be ensured by means of suitable design of the customer application or other action taken by the customer (e.g. installation of protective circuitry or redundancy) that no injury or damage is sustained by third parties in the event of malfunction or failure of an electronic component.
3. **The warnings, cautions and product-specific notes must be observed.**
4. In order to satisfy certain technical requirements, **some of the products described in this publication may contain substances subject to restrictions in certain jurisdictions (e.g. because they are classed as hazardous)**. Useful information on this will be found in our Material Data Sheets on the Internet ([www.tdk-electronics.tdk.com/material](http://www.tdk-electronics.tdk.com/material)). Should you have any more detailed questions, please contact our sales offices.
5. We constantly strive to improve our products. Consequently, **the products described in this publication may change from time to time**. The same is true of the corresponding product specifications. Please check therefore to what extent product descriptions and specifications contained in this publication are still applicable before or when you place an order.

We also **reserve the right to discontinue production and delivery of products**. Consequently, we cannot guarantee that all products named in this publication will always be available. The aforementioned does not apply in the case of individual agreements deviating from the foregoing for customer-specific products.

6. Unless otherwise agreed in individual contracts, **all orders are subject to our General Terms and Conditions of Supply**.
7. **Our manufacturing sites serving the automotive business apply the IATF 16949 standard**. The IATF certifications confirm our compliance with requirements regarding the quality management system in the automotive industry. Referring to customer requirements and customer specific requirements ("CSR") TDK always has and will continue to have the policy of respecting individual agreements. Even if IATF 16949 may appear to support the acceptance of unilateral requirements, we hereby like to emphasize that **only requirements mutually agreed upon can and will be implemented in our Quality Management System**. For clarification purposes we like to point out that obligations from IATF 16949 shall only become legally binding if individually agreed upon.

## Important notes

8. The trade names EPCOS, CarXield, CeraCharge, CeraDiode, CeraLink, CeraPad, CeraPlas, CSMP, CTVS, DeltaCap, DigiSiMic, FilterCap, FormFit, InsuGate, LeaXield, MediPlas, MiniBlue, MiniCell, MKD, MKK, ModCap, MotorCap, PCC, PhaseCap, PhaseCube, PhaseMod, PhiCap, PiezoBrush, PlasmaBrush, PowerHap, PQSine, PQvar, SIFERRIT, SIFI, SIKOREL, SilverCap, SIMDAD, SiMic, SIMID, SineFormer, SIOV, SurfIND, ThermoFuse, WindCap, XieldCap are **trademarks registered or pending** in Europe and in other countries. Further information will be found on the Internet at [www.tdk-electronics.tdk.com/trademarks](http://www.tdk-electronics.tdk.com/trademarks).

Release 2024-02