



Contents

<i>Description</i>	<i>Page</i>
5 x 15mm fuses	4-2
5 x 20mm IEC fuses	4-3
5 x 20mm UL fuses	4-5
1/4" x 5/8" to 1" fuses	4-6
1/4" x 1 1/4" fast-acting fuses	4-7
1/4" x 1 1/4" time-delay fuses	4-8
PCB mount fuse holders	4-9
PCB fuseclips for 5mm dia. fuses	4-11
PCB fuseclips for 1/4" dia. fuses	4-12
PCB fuseclips for 9/32", 13/32" and 9/16" dia. fuses	4-14

Electronic fuses

5 x 15mm fuses

C515 (axial leads)

C519

Specifications

Description:
Time-delay fuse.

Dimensions:
5 x 15mm
(0.197" X 0.591").

Construction:
Glass tube.

Ratings:

- Volts — 125Vac (3.5-7A)
- 250Vac (125mA-3A)
- 32Vdc (self certified)
- Amps — 125mA-7A
- IR — 25A (350mA @ 600Vac)
- 35A (125mA-1A @ 250Vac)
- 100A (1.25-3A @ 250Vac)
- 400A (3.5-7A @ 125Vac)
- 10kA (125mA-3A @ 125Vac)

Agency information: CE, UL Listed File E19180, Guide JDYX 125mA-250mA and 375mA-3A, UL Recognized, File E19180, Guide JDYX2, 350mA and 3.5A-7A, CSA Certification File 53787, Class 1422-01, 125mA-250mA and 375mA-3A.

Features and benefits

- Time-delay for closer sizing on inductive circuits.

Typical application

- Electronic circuits
- Printed circuit boards

Catalog numbers (amps)

With axial leads		
C515-125-R	C515-800-R	C515-2.5-R
C515-250-R	C515-1-R	C515-3-R
C515-350-R	C515-1.25-R	C515-3.5-R
C515-375-R	C515-1.5-R	C515-4-R
C515-500-R	C515-1.6-R	C515-5-R
C515-600-R	C515-2-R	C515-6-R
C515-750-R	C515-2.25-R	C515-7-R
Without axial leads		
C519-125-R	C519-750-R	C519-2.25-R
C519-250-R	C519-1-R	C519-2.5-R
C519-350-R	C519-1.25-R	C519-3-R
C519-375-R	C519-1.5-R	C519-3.5-R
C519-500-R	C519-1.6-R	C519-4-R
C519-600-R	C519-2-R	C519-5-R



C518 (axial leads)

C520

Specifications

Description:
Fast-acting fuse.

Dimensions:
5 x 15mm
(0.197" X 0.591").

Construction:
Glass tube.

Ratings:

- Volts — 250Vac
- 32Vdc (self certified)
- Amps — 100mA-5A
- IR — 35A (100mA-750mA @ 250Vac)
- 10kA (100mA-5A @ 125Vac)
- 100A (1.5-3.5A @ 250Vac)
- 200A (4-5A @ 250Vac)

Agency information: CE, UL Recognized File E19180, Guide JDYX2CSA Certification File 53787, Class 1422-01.

Features and benefits

- Small footprint saves space in equipment.
- Fast-acting for maximum component protection.
- Available in ferrule and axial leaded configurations

Typical applications

- Electronic circuits
- Printed circuit boards

Catalog numbers (amps)

With axial leads		
C518-100-R	C518-750-R	C518-4-R
C518-125-R	C518-2-R	C518-5-R
C518-250-R	C518-2.5-R	
C518-375-R	C518-3-R	
C518-500-R	C518-3.5-R	
Without axial leads		
C520-100-R	C520-750-R	C520-3.5-R
C520-125-R	C520-1.5-R	C520-4-R
C520-250-R	C520-2-R	C520-5-R
C520-375-R	C520-2.5-R	
C520-500-R	C520-3-R	



C517 (axial leads)

Specifications

Description: Fast-acting fuse.

Construction: Glass tube.

Ratings:

- Volts — 350Vac*
- 32Vdc (self certified)
- Amps — 3A
- IR — 100A @ 350Vac
- 100A @ 250Vac
- 10kA @ 125Vac

*350Vac/100A IR is UL Recognized

Agency information: CE, UL Listing File E19180, Guide JDYX, CSA Certification File 53787, Class 1422-01, UL Recognized, File E19180, Guide JDYX2.

- Small footprint saves space in equipment.
- Fast-acting for maximum component protection.
- 350Vac rating for 277V ballast circuit protection.

Typical applications

- Electronic circuits
- Printed circuit boards
- Electronic ballast protection

Catalog number (amps)

With axial leads
C517-3-R



S500-V (GDB-V)* (axial leads)

S500 (GDB)*

Specifications

Description: Fast-acting, low-breaking capacity fuse.

Construction:

Glass tube, nickel-plated brass endcaps (silver-plated endcaps, 32-125mA).

Ratings:

- Volts — 250Vac (or less)
- 32Vdc (self certified)
- Amps — 32mA-10A
- IR — See catalog table

Agency information: CE, cURus, SEMKO, VDE, BSI, IMQ, CCC. See data sheet for complete agency information. Not all approvals apply to all ratings.

Features and benefits

- Fast-acting for maximum protection, conforms to IEC 60127-2 (160mA-10A).

Typical applications

- Electronic circuits

Catalog numbers (amps)

Catalog numbers	IR (amps)	I ² t	Max voltage drop (mV)
S500-32-R	35	0.000047	3200
S500-40-R	35	0.00011	2500
S500-50-R	35	0.00020	2400
S500-63-R	35	0.00057	2000
S500-80-R	35	0.0012	1200
S500-100-R	35	0.003	1100
S500-125-R	35	0.005	1000
S500-160-R	35	0.008	2000
S500-200-R	35	0.016	1700
S500-250-R	35	0.028	1400
S500-315-R	35	0.058	1300
S500-400-R	35	0.018	1100
S500-500-R	35	0.018	220
S500-630-R	35	0.035	220
S500-800-R	35	0.067	190
S500-1-R	35	0.60	200
S500-1.25-R	35	0.84	200
S500-1.6-R	35	1.6	190
S500-2-R	35	4.2	150
S500-2.5-R	35	6.1	150
S500-3.15-R	35	13	130
S500-4-R	40	22	130
S500-5-R	50	42	120
S500-6.3-R	63	69	120
S500-8-R	80	-	120
S500-10-R	100	-	120

Options

Axial leads, put “V” in P/N,
*When ordering GDB version, do not add “-R” suffix to part number.

Data Sheet: 2052 (S500), 2015 (GDB)

S501-V (GDA-V)* (axial leads)

S501 (GDA)*

Specifications

Description: Fast-acting, high-breaking capacity fuse.

Construction:

Ceramic tube, nickel-plated brass endcaps (silver-plated endcaps 50mA-400mA).

Ratings:

- Volts — 250Vac (or less)
- 32Vdc (self certified)
- Amps — 50mA-10A**
- IR — 1500A @ 250Vac

Agency information: CE, cURus, SEMKO, VDE, IMQ, CCC, CSA, BSI. See data sheet for complete agency information. Not all approvals apply to all ratings.

Features and benefits

- Fast-acting for maximum protection.
- High break capacity for use in higher fault energy electronic circuitry.
- Conforming to IEC standards.

Typical applications

- Electronic circuits

Catalog numbers (amps)

Catalog numbers	I ² t	Typical voltage drop (mV)
S501-50-R	0.0017	9000
S501-63-R	0.0005	3300
S501-80-R	0.0011	2600
S501-100-R	0.0018	2300
S501-125-R	0.0037	1900
S501-160-R	0.008	1600
S501-200-R	0.020	1350
S501-250-R	0.027	1300
S501-315-R	0.010	1400
S501-400-R	0.018	1200
S501-500-R	0.038	1050
S501-630-R	0.064	1200
S501-800-R	0.097	490
S501-1-R	0.146	330
S501-1.25-R	0.313	297
S501-1.6-R	0.748	239
S501-2-R	2.0	205
S501-2.5-R	3.9	190
S501-3.15-R	8.1	160
S501-4-R	14	160
S501-5-R	25	155
S501-6.3-R	48	150
S501-8-R	N/A	N/A
S501-10-R	N/A	N/A

Options

Axial leads, put “V” in P/N.
*When ordering GDA version, do not add “-R” suffix to part number.
**GDA is not available above 6.3A.

Data Sheet: 2051 (S501), 2014 (GDA)

S505-V (axial leads)

S505

Specifications

Description: Time-delay, high-breaking capacity fuse.

Construction:

Ceramic tube, silver-plated brass endcaps.

Ratings:

- Volts — 250Vac (or less)
- 32Vdc (self certified)
- Amps — 500mA-12A
- IR — 1500A @ 250Vac

Agency information: UL, CSA, SEMKO, VDE, BSI, IMQ, PSE/JET, CCC, EK, FIMKO.

See data sheet for complete agency information. Not all approvals apply to all ratings.

Features and benefits

- Time-delay performance ideal for inductive circuits.
- Conforming to IEC standards.

Typical applications

- Electronic circuits

Catalog numbers (amps)

Catalog numbers	Typical I ² t	Max voltage drop (mV)
S505-500-R	0.188*	295
S505-800-R	0.632*	189
S505-1-R	1.28	152.5
S505-1.25-R	2.22	150
S505-1.6-R	6.78	125
S505-2-R	9.60	118.5
S505-2.5-R	16.60	115
S505-3.15-R	36.60	102.5
S505-4-R	38.45*	86.5
S505-5-R	71.30*	77.5
S505-6.3-R	197	75
S505-8-R	311	75
S505-10-R	397	72
S505-12-R	713.7*	77

*The typical I²t value was measured at 10 times of rated current under DC.

Options

Axial leads, put “V” in P/N.

Data Sheet: 2037

Electronic fuses

S505H (S505H-V)*

(axial leads)

Specifications**Description:** Time-delay, high-breaking capacity fuse.**Construction:**

Ceramic tube, nickel-plated brass endcaps.

Ratings:

Volts — 600Vac/400Vdc
 — 500mA-5A
 — 6.3A-10A
 — 500Vac/400Vdc

Amps — 500mA-10A

IR — 35A @ 250Vac

Agency information: cURus, CCC, CQC, TUV, PSE/JET.

See data sheet for complete agency information. Not all approvals apply to all ratings.

Features and benefits

- Time-delay, high breaking capacity
- Conforming to IEC standards

Typical applications

- Power supplies - adapters
- Desktops/notebooks

Catalog numbers (amps)

Catalog numbers	Typical I^2t (A ² s) ¹	Max voltage drop (mV) ³
S505H-500-R	0.188	295
S505H-800-R	0.632	189
S505H-1-R	1.28	153
S505H-1.25-R	2.22	150
S505H-1.6-R	6.78	125
S505H-2-R	11.44	128
S505H-2.5-R	24.23	126
S505H-3.15-R	43.55	121
S505H-4-R	38.45	90
S505H-5-R	71.3	89
S505H-6.3-R	111.4	80
S505H-8-R	228.2	76
S505H-10-R	349.5	72

1. Typical Pre-Arc Pt: Measured at 10I_n DC.
2. - Breaking Capacity of 250VAC/1500A is tested by all agency approvals, test condition is 250Vac, PF: 0.7-0.8.
 - Breaking Capacity of Max. voltage is tested by UL, PF:1.
 - Breaking Capacity Test of DC is tested by UL under Capacitor Bank 4800mF (for 400V, 1500A) 2400mF (for 400V, 500A).
3. Typical Voltage Drop: Voltage drop is measured under ambient 20°C with rated current.

Options

Axial leads, put "V" in P/N.

Data Sheet: 4406

S506-V (GDC-V)* (axial leads)**S506 (GDC)*****Specifications****Description:** Time-delay, low-breaking capacity fuse.**Construction:** Glass tube, nickel-plated brass endcaps.**Ratings:**

Volts — 250Vac (or less)
 — 32Vdc (self certified)
 Amps — 32mA-15A**
 IR — 35A @ 250Vac

Agency information: UR, CSA, cURus, SEMKO, VDE, BSI, IMQ, PSE/JET, CCC.

See data sheet for complete agency information. Not all approvals apply to all ratings.

Features and benefits

- Time-delay compatibility for inductive circuits
- Conforming to IEC standards

Typical applications

- Electronic circuits

Catalog numbers (amps)

Catalog numbers	Typical I^2t	Max voltage drop (mV)
S506-32-R	0.0051	1050
S506-40-R	0.0072	920
S506-50-R	0.0095	800
S506-63-R	0.021	760
S506-80-R	0.038	580
S506-100-R	0.045	490
S506-125-R	0.063	390
S506-160-R	0.093	320
S506-200-R	0.114	340
S506-250-R	0.265	270
S506-315-R	0.621	250
S506-400-R	0.872	210
S506-500-R	0.827	140
S506-630-R	1.33	150
S506-800-R	2.78	75
S506-1-R	6.45	87.5
S506-1.25-R	10.05	86
S506-1.6-R	21.7	82
S506-2-R	31.6	77
S506-2.5-R	59.4	72.5
S506-3.15-R	96.4	68.5
S506-4-R	71.8	67
S506-5-R	142.5	60.5
S506-6.3-R	237.6	54
S506-8-R	255.8	55
S506-10-R	450	54
S506-12.5-R	1019.5	45
S506-15-R	1091.7	65.5

Options

Axial leads, put "V" in P/N.

*When ordering GDC version, do not add "-R" suffix to part number.

**GDC series is not available above 6.3A.

Data Sheet: 2016 (GDC), 4332 (S506)

GMA-V (axial leads)

GMA

Specifications

Description: Fast-acting fuse.

Dimensions: 5 x 20mm (0.197" x 0.788").

Construction: Glass tube, nickel-plated brass endcaps.

Ratings:

- Volts — 250Vac (63mA-2.5A)
- 125Vac (3.15-15A)
- 32Vdc (self certified)
- Amps — 63mA-15A
- IR — 35A (63mA- 1A @ 250Vac, p.f. = 0.7-0.8)
- 10kA (63mA-6A @ 125Vac, p.f. = 0.7-0.8)
- 100A (1.25-2.5A @ 250Vac, p.f. = 0.7-0.8)
- 200A (7-8A @ 125Vac, p.f. = 1.0)
- 150A (10-15A @ 125Vac, p.f. = 1.0)

Agency information: CE, Std. 248-14 UL Listed Guide JDYX, File E19180, 0-6A, UL Recognized, Guide JDYX2, File E19180, 7-15A, CSA Certified, Class 1422-01, File 53787, 0-6.

Features and benefits

- Fast-acting for maximum protection.

Typical applications

- Electronic circuits

Catalog numbers (amps)

With axial leads		
GMA-V-63-R	GMA-V-800-R	GMA-V-4-R
GMA-V-100-R	GMA-V-1-R	GMA-V-5-R
GMA-V-125-R	GMA-V-1.25-R	GMA-V-6-R
GMA-V-200-R	GMA-V-1.5-R	GMA-V-7-R
GMA-V-250-R	GMA-V-1.6-R	GMA-V-8-R
GMA-V-300-R	GMA-V-2-R	GMA-V-10-R
GMA-V-500-R	GMA-V-2.5-R	GMA-V-15-R
GMA-V-600-R	GMA-V-3.15-R	
GMA-V-750-R	GMA-V-3.5-R	
Without axial leads		
GMA-63-R	GMA-800-R	GMA-4-R
GMA-100-R	GMA-1-R	GMA-5-R
GMA-125-R	GMA-1.25-R	GMA-6-R
GMA-200-R	GMA-1.5-R	GMA-7-R
GMA-250-R	GMA-1.6-R	GMA-8-R
GMA-300-R	GMA-2-R	GMA-10-R
GMA-500-R	GMA-2.5-R	GMA-15-R
GMA-600-R	GMA-3.15-R	
GMA-750-R	GMA-3.5-R	

Data Sheet: 2017



GMC-V (axial leads)

GMC

Specifications

Description: Medium time-delay fuse.

Dimensions: 5 x 20mm (0.197" x 0.788").

Construction: Glass tube, nickel-plated brass endcaps.

Ratings:

- Volts — 250Vac (63mA-3.15A)
- 125Vac (3.5-10A)
- 32Vdc (self certified)
- Amps — 63mA-10A
- IR — 35A (63mA- 1A @ 250Vac, p.f. = 0.7-0.8)
- 10kA (63mA-6A @ 125Vac, p.f. = 0.7-0.8)
- 100A (1.25-3.15A @ 250Vac, p.f. = 0.7-0.8)
- 200A (6.3-10A @ 125Vac, p.f. = 1.0)

Agency information: CE, Std. 248-14, UL Listed Guide JDYX, File E19180, 0-6.3A, UL Recognized, Guide JDYX2, File E19180, 7-8A, CSA Certified, Class 1422-01, File 53787, 0-6.3A.

Features and benefits

- Conforming to UL standards.

Typical applications

- Electronic circuits

Catalog numbers (amps)

With axial leads		
GMC-V-63-R	GMC-V-500-R	GMC-V-2.5-R
GMC-V-80-R	GMC-V-600-R	GMC-V-3.15-R
GMC-V-100-R	GMC-V-630-R	GMC-V-3.5-R
GMC-V-125-R	GMC-V-750-R	GMC-V-4-R
GMC-V-150-R	GMC-V-800-R	GMC-V-5-R
GMC-V-200-R	GMC-V-1-R	GMC-V-6-R
GMC-V-250-R	GMC-V-1.25-R	GMC-V-6.3-R
GMC-V-300-R	GMC-V-1.5-R	GMC-V-7-R
GMC-V-315-R	GMC-V-1.6-R	GMC-V-8-R
GMC-V-400-R	GMC-V-2-R	GMC-V-10-R
Without axial leads		
GMC-63-R	GMC-500-R	GMC-2.5-R
GMC-80-R	GMC-600-R	GMC-3.15-R
GMC-100-R	GMC-630-R	GMC-3.5-R
GMC-125-R	GMC-750-R	GMC-4-R
GMC-150-R	GMC-800-R	GMC-5-R
GMC-200-R	GMC-1-R	GMC-6-R
GMC-250-R	GMC-1.25-R	GMC-6.3-R
GMC-300-R	GMC-1.5-R	GMC-7-R
GMC-315-R	GMC-1.6-R	GMC-8-R
GMC-400-R	GMC-2-R	GMC-10-R

Data Sheet: 4395



GMD-V (axial leads)

GMD

Specifications

Description: Time-delay fuse.

Dimensions: 5 x 20mm (0.197" x 0.788").

Construction: Glass tube, nickel-plated brass endcaps.

Ratings:

- Volts — 250Vac
- 32Vdc (self certified)
- Amps — 125mA-4A
- IR — 10kA (125mA-3A @ 125Vac, p.f. = 0.7-0.8)
- 10kA (4A @ 125Vac, p.f. = 1.0)
- 35A (125mA-1A @ 250Vac, p.f. = 0.7-0.8)
- 100A (1.2A-3.A @ 250Vac, p.f. = 0.7-0.8)
- 200A (4A @ 250Vac, p.f. = 1.0)

Agency information: CE, UL Listed Guide JDYX, File E19180, 125mA-3A, UL Recognized, Guide JDYX2, File E19180, 4A, CSA Certified, Class 1422-01, File 53787, 0-4A, PSE/JET. File 1641-31003-1001, 1.2A-4A.

Features and benefits

- Time-delay compatibility for inductive circuits.
- Conforming to UL standards.

Typical applications

- Electronic circuits

Catalog numbers (amps)

With axial leads		
GMD-V-125-R	GMD-V-500-R	GMD-V-1.5-R
GMD-V-150-R	GMD-V-600-R	GMD-V-1.6-R
GMD-V-200-R	GMD-V-630-R	GMD-V-2-R
GMD-V-250-R	GMD-V-750-R	GMD-V-2.5-R
GMD-V-300-R	GMD-V-800-R	GMD-V-3-R
GMD-V-315-R	GMD-V-1-R	GMD-V-4-R
GMD-V-375-R	GMD-V-1.2-R	
GMD-V-400-R	GMD-V-1.25-R	
Without axial leads		
GMD-125-R	GMD-500-R	GMD-1.5-R
GMD-150-R	GMD-600-R	GMD-1.6-R
GMD-200-R	GMD-630-R	GMD-2-R
GMD-250-R	GMD-750-R	GMD-2.5-R
GMD-300-R	GMD-800-R	GMD-3-R
GMD-315-R	GMD-1-R	GMD-4-R
GMD-375-R	GMD-1.2-R	
GMD-400-R	GMD-1.25-R	

Data Sheet: 2019



Electronic fuses

4

Electronic – PCB and small dimension fuses

1/4" x 5/8" to 1" fuses

AGA

Specifications

Description: Fast-acting fuse.

Dimensions:

1/4" x 5/8"
(6.4 x 15.9mm).

Construction: Glass tube.

Ratings:

Volts — 125Vac (or less)
— 32Vdc (self certified)

Amps — 1-30A

IR — 10kA (1-1½A @ 125Vac)
— 200A (2-5A @ 125Vac)
— 1000A (6-30A @ 32Vac)

Agency information: CE, Std. 248-14, UL File E19180, UL Listed, Guide JDYX 0-3½A UL Recognized, Guide JDYX2 12-30A.

Features and benefits

- Fast-acting for maximum protection.
- Size rejects insertion of other fuse types.

Typical applications

- Electronic circuits

Catalog numbers (amps)

AGA-1	AGA-5	AGA-15
AGA-1-½	AGA-6	AGA-20
AGA-2	AGA-7	AGA-25
AGA-2-½	AGA-7-½	AGA-30
AGA-3	AGA-10	



AGW

Specifications

Description: Fast-acting fuse.

Dimensions: ¼" x 1"
(6.4 x 22.2mm).

Construction: Glass tube.

Ratings:

Volts — 32Vac
— 32Vdc (self certified)

Amps — 1-30A

Features and benefits

- Fast-acting for maximum protection.

Typical applications

- Electronic circuits

Catalog numbers (amps)

AGW-1	AGW-4	AGW-15
AGW-1-½	AGW-5	AGW-20
AGW-2	AGW-6	AGW-25
AGW-2-½	AGW-7-½	AGW-30
AGW-3	AGW-10	



AGX

Specifications

Description: Fast-acting fuse.

Dimensions: ¼" x 1"
(6.4 x 25.4mm).

Construction: Glass tube.

Ratings:

Volts — 250Vac (1/16-20A)
— 125Vac (25-30A)
— 32Vdc (1/16-30A)

Amps — 1/16-30A

IR — 35A (1/16-1A @ 250Vac)
— 10kA (1/16-10A @ 125Vac)
— 200A (15-20A @ 125Vac)
— 100A (25-30A @ 125Vac)
— 1000A (8-30A @ 32Vac)

Agency information: cULus: AGX 0-10A (Guide JDYX, File E 19180 and Guide JDYX7, File E19180), UL Recognized Card: AGX 15-30A (Guide JDYX2, File E19180), CSA Component Acceptance Card : AGX 15-30A (Class No. 1422-01, File 53787)

Features and benefits

- Size rejects insertion of other fuse types.

Typical applications

- Electronic circuits

Catalog numbers (amps)

AGX-1/16	AGX-1-1/2	AGX-8
AGX-3/16	AGX-2	AGX-10
AGX-1/8	AGX-2-1/2	AGX-15
AGX-1/4	AGX-3	AGX-20
AGX-1/2	AGX-4	AGX-25
AGX-3/4	AGX-5	AGX-30
AGX-1	AGX-6	
AGX-1-1/4	AGX-7	



AGC (AGC-V axial leads)

Specifications

Description: Fast-acting fuse.

Dimensions: 1/4" x 1 1/4" (6.4 x 31.7mm).

Construction: Glass tube with nickel-plated brass endcaps.

Ratings:

- Volts — 250Vac (1/20-10A)
- 32Vac (12-40A)
- 32Vdc (self certified)

Amps — 1/20-40A

- IR — 35A (1/20-1A @ 250Vac)
- 100A (1 1/4-3A @ 250Vac)
- 200A (4-10A @ 250Vac)
- 10kA (1/20-10A @ 125Vac)
- 1000A (12-40A @ 32Vac)

Agency information: CE, UL Listed, Guide JDYX, File E19180, 0-10A UL Recognized, Guide JDYX2, File E19180, 12-30A CSA Certification, Class 1422-01, File 053787, 1/20-30A.

Features and benefits

- Original electronic glass tube fuse.
- Fast-acting for maximum protection.
- Wide amp/volt ratings allow versatility of protecting electronic circuits.

Typical applications

- Electronic circuits

Catalog numbers (amps)

With axial leads		
AGC-V-1/20-R	AGC-V-1-1/4-R	AGC-V-8-R
AGC-V-1/10-R	AGC-V-1-1/2-R	AGC-V-9-R
AGC-V-1/6-R	AGC-V-2-R	AGC-V-10-R
AGC-V-3/16-R	AGC-V-2-1/2-R	AGC-V-12-R
AGC-V-1/8-R	AGC-V-2-1/2-R	AGC-V-14-R
AGC-V-1/4-R	AGC-V-3-R	AGC-V-15-R
AGC-V-3/10-R	AGC-V-4-R	AGC-V-20-R
AGC-V-3/8-R	AGC-V-5-R	AGC-V-25-R
AGC-V-1/2-R	AGC-V-6-R	AGC-V-30-R
AGC-V-3/4-R	AGC-V-7-R	AGC-V-35-R
AGC-V-1-R	AGC-V-7-1/2-R	AGC-V-40-R

Without axial leads		
AGC-1/20-R	AGC-1-1/4-R	AGC-8-R
AGC-1/10-R	AGC-1-1/2-R	AGC-9-R
AGC-1/6-R	AGC-2-R	AGC-10-R
AGC-3/16-R	AGC-2-1/2-R	AGC-12-R
AGC-1/8-R	AGC-2-1/2-R	AGC-14-R
AGC-1/4-R	AGC-3-R	AGC-15-R
AGC-3/10-R	AGC-4-R	AGC-20-R
AGC-3/8-R	AGC-5-R	AGC-25-R
AGC-1/2-R	AGC-6-R	AGC-30-R
AGC-3/4-R	AGC-7-R	AGC-35-R
AGC-1-R	AGC-7-1/2-R	AGC-40-R

Data Sheet: 2543



ABC (ABC-V axial leads)

Specifications

Description: Fast-acting fuse.

Dimensions: 1/4" x 1 1/4" (6.4 x 31.7mm).

Construction: Ceramic tube with nickel-plated brass endcaps.

Ratings:

- Volts — 250Vac/125Vdc (1/4-15A, 20-30A)*
- 250Vac (18A)
- 32Vdc (self certified)

Amps — 1/4-30A

- IR** — 35A (1/4-1A @ 250Vac)
- 100A (1 1/4-3A @ 250Vac)
- 200A (4-10A @ 250Vac)
- 750A (12-15A @ 250Vac)
- 400A (18-20A @ 250Vac)
- 10kA (1/4-15A @ 125Vac)
- 1kA (18-30A @ 125Vac)
- 10kA (1/4-15, 20A @ 125Vdc)
- 400A (25-30A @ 125Vdc)
- 200A (25-30A @ 250Vac)

*CSA approvals for 25A and 30A are at 125Vac – IR 1000A and Vdc – IR 400A (IR 1000A at 75Vdc)

**Interrupting ratings measured at 70% – 80% power factor on AC. The interrupting ratings for 18A and 20A were measured at 85%-95% power factor on AC. The interrupting ratings for 25A and 30A were measured at 89% power factor on AC.

Agency information: CE, Std. 248-14 UL Listed, Guide JDYX File E19180, 1/4-15A; UL Recognized, Guide JDYX2, File E19180, 18-30A; CSA Certification, Class 1422-01 & 1422-30, File 53787, 1/4-30A.

Features and benefits

- Ceramic body allows for higher amp/volt rating combinations.

Typical applications

- Electronic circuits

Catalog numbers (amps)

With axial leads		
ABC-V-1/4-R	ABC-V-3-R	ABC-V-12-R
ABC-V-1/2-R	ABC-V-4-R	ABC-V-15-R
ABC-V-3/8-R	ABC-V-5-R	ABC-V-18-R
ABC-V-1-R	ABC-V-6-R	ABC-V-20-R
ABC-V-1-1/2-R	ABC-V-7-R	ABC-V-25-R
ABC-V-2-R	ABC-V-8-R	ABC-V-30-R
ABC-V-2-1/2-R	ABC-V-10-R	

Without axial leads		
ABC-1/4-R	ABC-3-R	ABC-12-R
ABC-1/2-R	ABC-4-R	ABC-15-R
ABC-3/8-R	ABC-5-R	ABC-18-R
ABC-1-R	ABC-6-R	ABC-20-R
ABC-1-1/2-R	ABC-7-R	ABC-25-R
ABC-2-R	ABC-8-R	ABC-30-R
ABC-2-1/2-R	ABC-10-R	

Data Sheet: 2000



GBB (GBB-V axial leads)

Specifications

Description: Very fast-acting fuse.

Dimensions: 1/4" x 1 1/4" (6.4 x 31.7mm).

Construction: Ceramic cartridge with nickel-plated brass endcaps.

Ratings:

- Volts — 250Vac/125Vdc
- Amps — 1-30A
- IR — 200A @ 250Vac
- 200A (20-30A @ 125Vac/dc)
- 10,000A (1A -15A @ 125Vac/dc)

Agency information:

CE, Std. 248-14, UL Recognized, 1-30, 125Vdc/250Vac, File E56412, Guide JFHR2, CSA Accepted, 1-30, 125Vdc/250Vac, File 53787, Class 1422-30.

Features and benefits

- Very fast-acting performance allows protection of highly sensitive electronic circuitry.

Typical applications

- Electronic circuits

Catalog numbers (amps)

With axial leads		
GBB-V-1-R	GBB-V-6-R	GBB-V-15-R
GBB-V-1-1/4-R	GBB-V-7-R	GBB-V-20-R
GBB-V-2-R	GBB-V-8-R	GBB-V-25-R
GBB-V-3-R	GBB-V-9-R	GBB-V-30-R
GBB-V-4-R	GBB-V-10-R	
GBB-V-5-R	GBB-V-12-R	

Without axial leads		
GBB-1-R	GBB-6-R	GBB-15-R
GBB-1-1/4-R	GBB-7-R	GBB-20-R
GBB-2-R	GBB-8-R	GBB-25-R
GBB-3-R	GBB-9-R	GBB-30-R
GBB-4-R	GBB-10-R	
GBB-5-R	GBB-12-R	

Data Sheet: 2013



Electronic fuses

1/4" x 1 1/4" time-delay fuses

MDL-V (axial leads)

MDL

Specifications Description:
Time-delay fuse.

Dimensions: 1/4" x 1 1/4"
(6.4 x 31.7mm).

Construction:

Glasstube with nickel-plated brass endcaps.

Ratings:

Volts — 250Vac (1/16-8A)
— 32Vac (9-30A)
— 32Vdc (Self Certified)

Amps — 1/16-30A

IR* — 35A (1/16-1A @ 250Vac)
— 100A (1 1/4-3A @ 250Vac)
— 200A (4-8A @ 250Vac)
— 10000A (1/16-8A @ 125Vac)
— 1000A (9-30A @ 32Vac)

*Interrupting ratings were measured at 70% – 80% power factor on AC, and at a time constant described in UL 198L.

Agency information: CE, UL Listed, Guide JDYX, File E19180, 1/16-8A; CSA Certification Class 1422-01, 1/16-8A; UL Recognized, Guide JDYX2, File E19180, 9-30A; CSA Component Acceptance, Class 142230, 9-30A.

Features and benefits

- Time-delay allows close sizing on inductive circuits.

Typical applications

- Electronic circuits

Catalog numbers (amps)

With axial leads

MDL-V-1/16-R	MDL-V-1-R	MDL-V-6-R
MDL-V-1/8-R	MDL-V-1-1/4-R	MDL-V-7-R
MDL-V-1/4-R	MDL-V-1-1/2-R	MDL-V-8-R
MDL-V-3/8-R	MDL-V-2-R	MDL-V-9-R
MDL-V-1/2-R	MDL-V-2-1/4-R	MDL-V-10-R
MDL-V-3/4-R	MDL-V-2-1/2-R	MDL-V-12-R
MDL-V-5/8-R	MDL-V-3-R	MDL-V-15-R
MDL-V-3/4-R	MDL-V-3-3/8-R	MDL-V-20-R
MDL-V-1-1/8-R	MDL-V-4-R	MDL-V-25*
MDL-V-1-1/4-R	MDL-V-5-R	MDL-V-30*

Without axial leads

MDL-1/16-R	MDL-1-R	MDL-6-R
MDL-1/8-R	MDL-1-1/4-R	MDL-7-R
MDL-1/4-R	MDL-1-1/2-R	MDL-8-R
MDL-3/8-R	MDL-2-R	MDL-9-R
MDL-1/2-R	MDL-2-1/4-R	MDL-10-R
MDL-3/4-R	MDL-2-1/2-R	MDL-12-R
MDL-5/8-R	MDL-3-R	MDL-15-R
MDL-3/4-R	MDL-3-3/8-R	MDL-20-R
MDL-1-1/8-R	MDL-4-R	MDL-25*
MDL-1-1/4-R	MDL-5-R	MDL-30*

*MDL-25 & MDL-30 are not available in RoHS compliant construction.

Data Sheet: 2004

MDQ-V (axial leads)

MDQ

Specifications Description:
Dual-element, time-delay fuse.

Dimensions: 1/4" x 1 1/4"
(6.4 x 31.7mm).

Construction: Glass tube with nickel-plated brass endcaps.

Ratings:

Volts — 250Vac (1/100-7A)
— 32Vac (7 1/2-15A)
— 32Vdc (Self Certified)

Amps — 1/100-15A

IR — 35A (1/100-1A @ 250Vac)
— 100A (1 1/4-3A @ 250Vac)
— 200A (4-7A @ 250Vac)
— 1000A (7 1/2-12A @ 32Vac)

Agency information: Std. 248-14, UL Listed, File E19180; Guide JDYX, 1/16-7A CSA Certification, File 47233, Class 1422-01, 1/16-7A, UL Recognized, Guide JDYX2, File E19180, 7.1-30A.

Features and benefits

- Dual-element design allows closer sizing to inductive circuits than any other fuses.

Typical applications

- Electronic relay and control circuits

Catalog numbers (amps)

With axial leads

MDQ-V-1/100	MDQ-V-1/50	MDQ-V-1-1/2	MDQ-V-5
MDQ-V-1/50	MDQ-V-1/25	MDQ-V-1-3/4	MDQ-V-6
MDQ-V-1/25	MDQ-V-1/10	MDQ-V-1-3/4	MDQ-V-6-1/4
MDQ-V-1/10	MDQ-V-1/5	MDQ-V-2	MDQ-V-7
MDQ-V-1/5	MDQ-V-3/10	MDQ-V-2-1/4	MDQ-V-7-1/2
MDQ-V-1/5	MDQ-V-3/10	MDQ-V-2-1/2	MDQ-V-8
MDQ-V-1/5	MDQ-V-3/10	MDQ-V-2-3/4	MDQ-V-9
MDQ-V-1/5	MDQ-V-1	MDQ-V-3	MDQ-V-10
MDQ-V-1/5	MDQ-V-1-1/10	MDQ-V-3-3/10	MDQ-V-12
MDQ-V-1/4	MDQ-V-1-1/4	MDQ-V-4	MDQ-15

Without axial leads

MDQ-1/100	MDQ-1/50	MDQ-1-1/2	MDQ-5
MDQ-1/50	MDQ-1/25	MDQ-1-3/4	MDQ-6
MDQ-1/25	MDQ-1/10	MDQ-1-3/4	MDQ-6-1/4
MDQ-1/10	MDQ-1/5	MDQ-2	MDQ-7
MDQ-1/5	MDQ-3/10	MDQ-2-1/4	MDQ-7-1/2
MDQ-1/5	MDQ-3/10	MDQ-2-1/2	MDQ-8
MDQ-1/5	MDQ-3/10	MDQ-2-3/4	MDQ-9
MDQ-1/5	MDQ-1	MDQ-3	MDQ-10
MDQ-1/5	MDQ-1-1/10	MDQ-3-3/10	MDQ-12
MDQ-1/4	MDQ-1-1/4	MDQ-4	MDQ-15

Data Sheet: 2044

MDA-V (axial leads)

MDA

Specifications Description: Time-delay fuse.
Dimensions: 1/4" x 1 1/4" (6.35 x 31.75mm).

Construction: Ceramic tube with nickel-plated brass endcaps.

Ratings:

Volts — 250Vac (or less)
— 125Vdc (20A- 30A)
— 32Vdc (Self certified)

Amps — 1/4-30A

IR** — 35A (1/4-1A @ 250Vac)
— 100A (1 1/2-2A @ 250Vac)
— 200A (2 1/2-10A @ 250Vac)
— 750A (12-15A @ 250Vac)
— 1500A (20-30A @ 250Vac)
— 10kA (1/4-30A @ 125Vac)
— 10kA (20-30A @ 125Vdc)

**Interrupting ratings were measured at 70% – 80% power factor on AC, and at a time constant described in UL 248.

Agency information: CE, Std. 248-14, UL Listed, Guide JDYX, File E19180, 0-20A CSA Certification, Class 1422-01, File 53787, 0-20A. UL Recognized, Guide JDYX2, File E19180, 25-30A, CSA Component Acceptance, Class 1422-30, 25-30A

Features and benefits

- Ceramic body allows for higher amp/volt rating combinations.
- Inventory consolidation by replacing MDL fuses allows for reduced SKU investment and minimizing potential for misapplying fuse.

Typical applications

- Electronic circuits

Catalog numbers (amps)

With axial leads

MDA-V-1/4-R	MDA-V-3-R	MDA-V-12-R
MDA-V-1/2-R	MDA-V-4-R	MDA-V-15-R
MDA-V-3/4-R	MDA-V-5-R	MDA-V-20-R
MDA-V-1-R	MDA-V-6-R	MDA-V-25A-R
MDA-V-1-1/2-R	MDA-V-7-R	MDA-V-30A-R
MDA-V-2-R	MDA-V-8-R	
MDA-V-2-1/2-R	MDA-V-10-R	

Without axial leads

MDA-1/4-R	MDA-3-R	MDA-12-R
MDA-1/2-R	MDA-4-R	MDA-15-R
MDA-3/4-R	MDA-5-R	MDA-20-R
MDA-1-R	MDA-6-R	MDA-25A-R
MDA-1-1/2-R	MDA-7-R	MDA-30A-R
MDA-2-R	MDA-8-R	
MDA-2-1/2-R	MDA-10-R	

Data Sheet: 2002

HTC-45M



PCB vertical mount

Specifications

Description: PCB vertical mount bayonet cap and fuse holder.

Dimensions: See dimensions illustration.

Ratings:

See specifications table.

Agency information:

See specifications table notes 1, 2, 5.

Dimensions - in (mm)

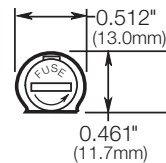
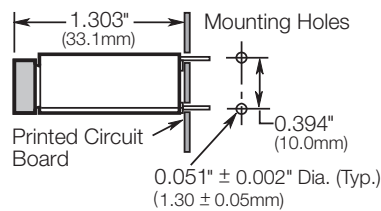

Data Sheet 2110

HTC-50M



PCB horizontal mount

Specifications

Description: PCB horizontal mount bayonet cap and fuse holder.

Dimensions: See dimensions illustration.

Ratings:

See specifications table.

Agency information:

See specifications table notes 1, 2.

Dimensions - in (mm)

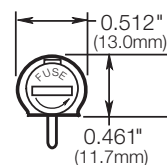
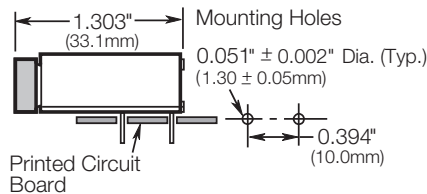

Data Sheet 2110

HTC-60M

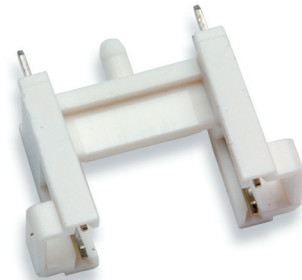

PCB stand-off mount

Specifications

Description: Four-leg PCB stand-off fuse holder.

Dimensions: See dimensions illustration.

Ratings:

Volts: — 250V

Amps: — 6.3A

Agency information:

See specifications table notes 1, 4.

Dimensions - in (mm)

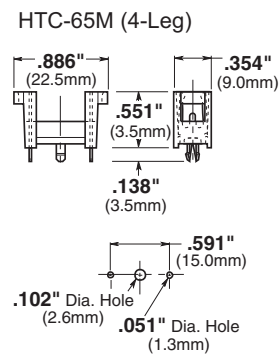

Data Sheet 2110

Electronic fuses

Specifications

Terminals — Tin-plated brass with 3mm (HTC-35M, -55M) and 4.8mm (HTC-70M).

Molded materials — High temperature thermoplastic that meets the flammability ratings of UL 94VO; Glow Wire Test: 960°C per IEC 695-2-1.

Solderability — In accordance with IEC 68-2-20.

Electrical — Contact resistance: ≤10mΩ; Insulation Resistance: ≥10MΩ; dielectric strength ≥2000Vac.

Ratings — 250V, 10A, UL

Shock safety — PC2 (fuse holders).

Agency information:

- 1) cURus: Guide 1ZLT2 & IZLT8, File E14853
- 2) VDE: 40004457
- 3) VDE: 40004458
- 4) VDE: 40004459
- 5) VDE: 40004463

HBH-I (for ¼" x 1 ¼" fuses)

HBH-M (for 5 x 20mm fuses)

PCB horizontal mount

Specifications

Description: PCB horizontal mount fuse holder.

Dimensions: See dimensions illustration.

Ratings:

See specifications table.



Dimensions - in (mm)

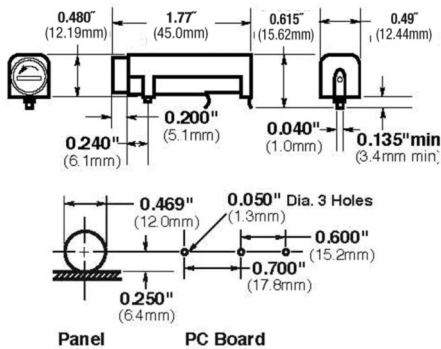

Data Sheet: 2118

HBV-I (for ¼" x 1 ¼" fuses)

HBV-M (for 5 x 20mm fuses)

PCB vertical mount with stability pins

Specifications

Description: PCB vertical mount fuse holder with stability pins.

Dimensions: See dimensions illustration.

Ratings:

See specifications table.



Dimensions - in (mm)

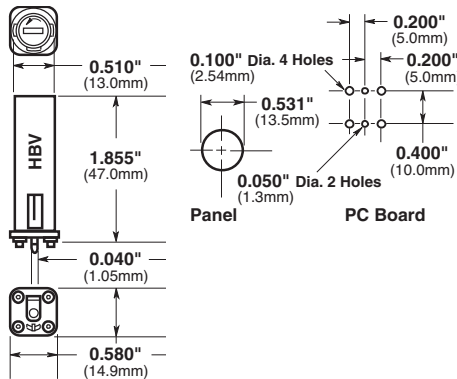

Data Sheet: 2118

HBW-I (for ¼" x 1 ¼" fuses)

HBW-M (for 5 x 20mm fuses)

PCB vertical mount without stability pins

Specifications

Description: PCB vertical mount fuse holder without stability pins.

Dimensions: See dimensions illustration.

Ratings:

See specifications table.



Dimensions - in (mm)

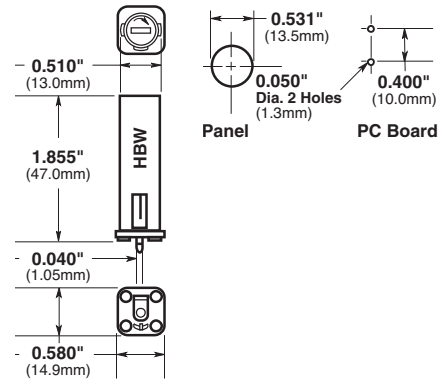

Data Sheet: 2118



FBI



FBM

Fuse holder caps (fit all three shown above)

Specifications

Electrical ratings: UL — 16A @ 250V; CSA — 12A @ 250V; VDE — 6.3A @ 250V; SEMKO — 10A @ 250V
Insulation resistance — 10 megohm at 500Vdc. Contact resistance — less than 0.005 ohms @ 200mV. Dielectric strength — over 200V/mil.

Molded material: High dielectric molded phenolic with a UL 94V0 flammability rating.

Fuse carrier and knob: Spring-loaded, bayonet-type. Tin plated brass. Screwdriver slotted.

Mounting: "Kicked" terminals (all models) and stabilizer pins on HBV and HBW models for increased stability.

Temperature Rating (RTI): Body: 150°C, Knob: 130°C

Agency information: CE, UL Recognized — Guide IZLT2, File EI4853;

CSA Certified — Class 6225-01, File 47235

VDE — 4009241 (HBV, HBW)

SEMKO — 800444

HTC-15M, HTC-140M

PCB mounted fuse holder and snap-on cover

Voltage rating: 250V, 6.3A, 1.6W

HTC-15M (fuse holder), HTC-140M (natural cover),
HTC-150M* (transparent cover)



Agency information: See specifications table notes 1, 3 on bottom of page 65

*Available in bulk only. Use this format: BK/HTC-150M

Data Sheet: 2110

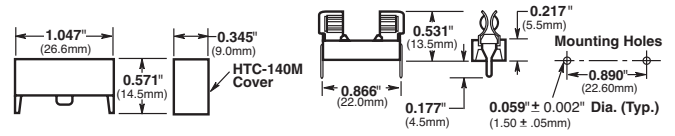

HTC-200M

PCB mounted fuseclip

Construction: Tin-plated bronze

Tape and fan fold packed

Ammo Pack (AP/HTC-200M) 1000 pieces per box

Data Sheet: 2110

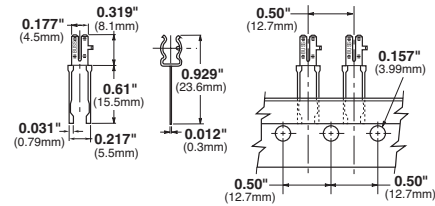

HTC-210M

PCB mounted fuseclip with end stops

Data Sheet: 2110

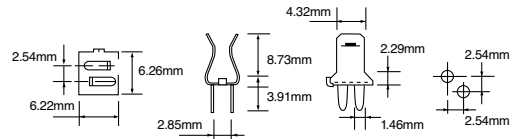

1A3399

PCB fuseclips with end stops and straight leads

Catalog numbers	Clip material*	Finish
1A3399-01	Beryllium copper*	Silver
1A3399-04-R	Beryllium copper*	Bright tin
1A3399-10-R	Spring bronze	Bright tin

*Beryllium copper recommended for amps higher than 15 amps.

Data Sheet: 2131

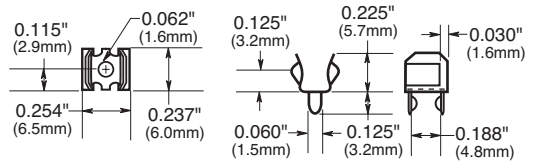

1A5018

PCB high profile fuseclips with end stops and straight leads

Catalog numbers	Clip material*	Finish
1A5018-07	Spring bronze	Silver
1A5018-10-R	Spring bronze	Bright tin

*Beryllium copper recommended for amps higher than 15 amps.

Data Sheet: 2131

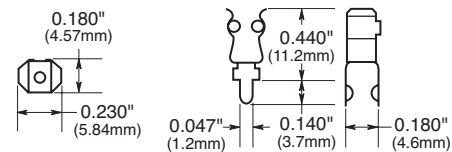

1A5601

PCB fuseclips (0-7A)

Catalog number	Clip material	Finish
1A5601	Cartridge brass	Bright tin

Data Sheet: 2131

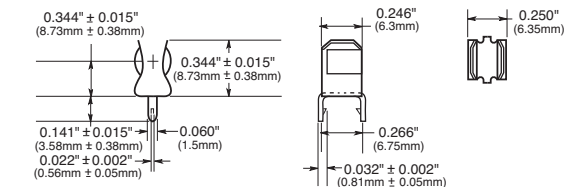

1A5602

PCB fuseclips (0-7A)

Catalog number	Clip material	Finish
1A5602	Cartridge brass	Bright tin

Data Sheet: 2131

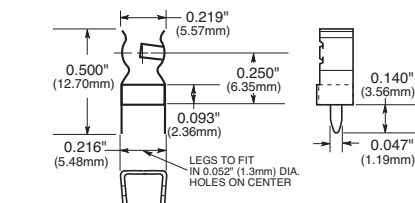

Electronic fuses

PC board fuseclips for 1/4" diameter fuses

1A3398

PCB fuseclips without end stops with straight leads

Catalog numbers	Clip material	Finish
1A3398-07-R	Cartridge brass	Bright tin

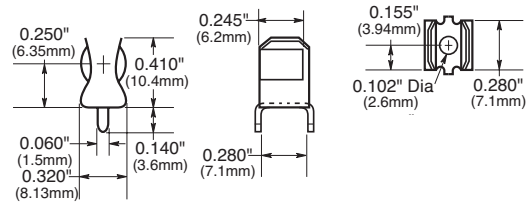

1A1907

PCB fuseclips with end stops and straight leads

Catalog numbers	Clip material*	Finish
1A1907-02	Cartridge brass	None/bright dipped
1A1907-03-R	High performance copper*	Bright tin
1A1907-05	High performance copper*	Silver
1A1907-06-R	Cartridge brass	Bright tin

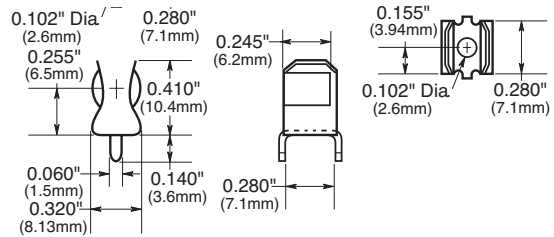

*High performance copper recommended for amps higher than 15A.
Data Sheet: 2131

1A4533

PCB fuseclips without end stops or angled out leads

Catalog numbers	Clip material*	Finish
1A4533-01-R	High performance copper*	Bright tin
1A4533-06-R	Cartridge brass	Bright tin

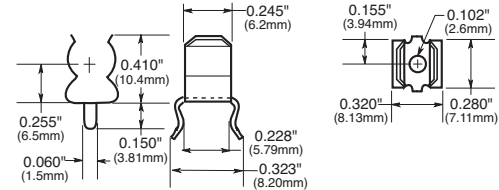

*High performance copper recommended for amps higher than 15A.
Data Sheet: 2131

1A4534

PCB fuseclips with end stops and angled out leads

Catalog numbers	Clip material*	Finish
1A4534-01-R	High performance copper*	Bright tin
1A4534-06-R	Cartridge brass	Bright tin

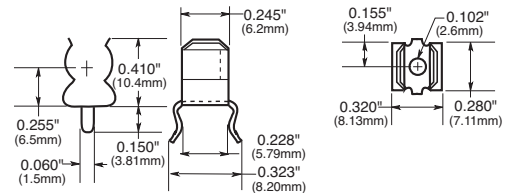

*High performance copper recommended for amps higher than 15A.
Data Sheet: 2131

1A1119

Fuseclips with end stops and angled in leads

Catalog numbers	Clip material*	Finish
1A1119-04-R	High performance copper*	Bright tin
1A1119-05	High performance copper*	Silver
1A1119-10-R	Cartridge brass	Bright tin

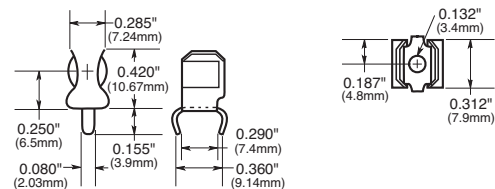

*High performance copper recommended for amps higher than 15A.
Data Sheet: 2131

1A1120

PCB fuseclips without end stops or angled in leads

Catalog numbers	Clip material*	Finish
1A1120-02	Cartridge brass	None/bright dipped
1A1120-05	High performance copper*	Silver
1A1120-06-R	High performance copper*	Bright tin
1A1120-09-R	Cartridge brass	Bright tin

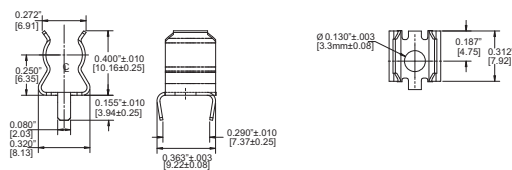

*High performance copper recommended for amps higher than 15A.
Data Sheet: 2131

5681 and 5682

PCB fuseclips with mounting holes For 1/4" diameter fuses

Catalog number	End stop	Clip mat.**	Finish	Dimensions (Inches)					Ref.
				B (To end stop)	C (Contact)	D (Height)	E (Width)	Hole dia.	
5681-01	No	BeCu	Silver	†	0.265	0.41	0.32	0.132	Fig. 2
5681-08		Spg. br.	Nickel						
5681-15-R		Spg. br.	Bright tin						
5682-01	Yes	BeCu	Silver	0.108	0.262	0.41	0.32	0.132	Fig. 1
5682-02		BeCu	Silver						
5682-11-R		BeCu	Bright tin	0.131					
5682-41-R		Spg. br.	Bright tin	0.106					
5682-44-R		Spg. br.	Bright tin	0.132					

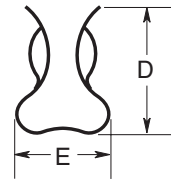
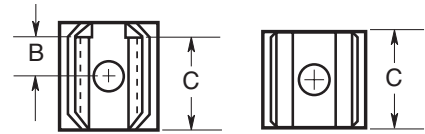

Figure 1

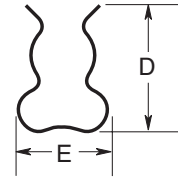

Figure 2

4

Electronic – PCB and small dimension fuses

PC board fuseclips for 9/32", 13/32" and 9/16" diameter fuses

5672 and 5674

PCB fuseclips with mounting holes for 9/32" diameter fuses

Catalog number	End stop	Clip mat.**	Finish	Dimensions (Inches)					Ref.
				B (To end stop)	C (Contact)	D (Height)	E (Width)	Hole dia.	
5672-11	No	Spg. br.	Bright tin	†	0.362	0.52	0.38	0.172	Fig. 2
5674-01	Yes	BeCu	Silver	0.168	0.356	0.52	0.38	0.172	Fig. 1
5674-10		BeCu	Bright tin						
5674-41		Spg. br.	Bright tin						

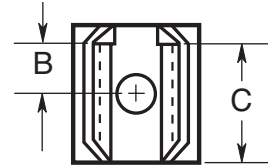

1A3400***

For 13/32" diameter fuses

With end stops and straight leads

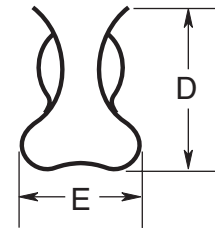
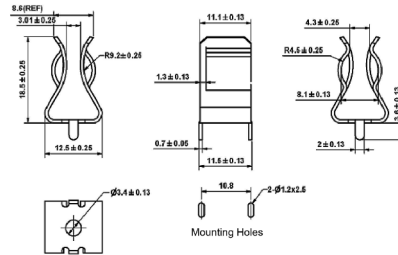
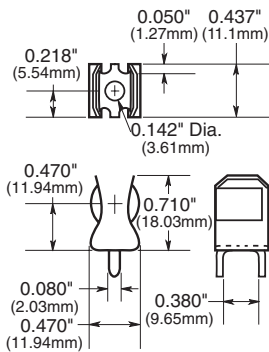

Figure 1

Dimensional data



1A3400-09 and 1A3400-10

1A3400-12

Specifications:

Catalog number	Clip material	Finish	Amp rating
1A3400-09	Copper-clad steel	Bright tin	20A max.
1A3400-10	Copper-clad steel	Silver	30A max.
1A3400-12	Spring brass	Bright tin	15A max.

***For RoHS compliant version add "-R" option code suffix to part number.

5956 and 5960

PCB fuseclips with mounting holes for 13/32" diameter fuses

Catalog number	End stop	Clip mat.**	Finish	Dimensions (inches)					Ref.	
				B (To end stop)	C	D	E	Hole dia.		
5956-16	No	Spg. br.	Bright tin	†	0.312	0.71	0.47	0.172	Fig. 2	
5960-07	Yes	BeCu	Silver	0.168	0.387	0.71	0.47	0.196	Fig. 1	
5960-09		BeCu	Silver							0.20
5960-44		Spg. br.	Nickel							0.20
5960-51		Spg. br.	Bright dip*							0.168
5960-53		Spg. br.	Bright dip*							0.20
5960-61-R		Spg. br.	Bright tin							0.168
5960-62-R		Spg. br.	Bright tin							0.168
5960-63-R		Spg. br.	Bright tin							0.20
5960-64-R		Spr. br.	Bright tin							0.20

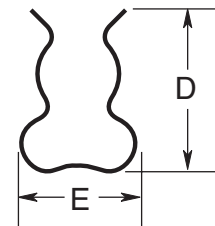
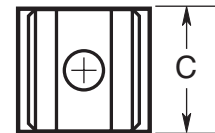

Figure 2

5591 and 5592

PCB fuseclips with mounting holes for 9/16" diameter fuses

Catalog number	End stop	Clip mat.**	Finish	Dimensions (inches)					Ref.
				B (To end stop)	C	D	E	Hole dia.	
5591-42	Yes	Spg. br.	Bright dip*	0.26	0.51	0.89	0.60	0.172	Fig. 1
5591-52-R		Spg. br.	Bright tin						
5592-01	No	BeCu	Silver	0.252	0.56	0.875	0.60	0.20	Fig. 2



* Bright dip is actually treated bare metal with no plating.
 ** Spg. br. — Spring bronze; BeCu — Beryllium copper.
 † Hole in center of both clip and contact area.

Data Sheet: 2132