

G9KC

PCB Power Relays

480 VAC 40 A 4-pole High Power Relay with Low Contact Resistance



- Low initial contact resistance: 6 mΩ max.
- 4-pole 40 A switching with compact size: W35 mm x L58 mm x H47 mm
- Contact gap: 3.6 mm min.
- High short circuit capacity conformed to IEC62955 (I_{nc}=10 kA, I_n≤32 A)
- Low coil power consumption: approx. 613 mW with holding voltage 35%
- Auxiliary contact conformed to IEC60947-4-1 mirror contact requirement

Refer to the *Precautions* on page 6.

Model Number Legend

G9KC-□□
1 2

- | | |
|----------------------|----------------------------|
| 1. Main Contact Form | 2. Auxiliary Contact Form |
| 4A: 4PST-NO (Form A) | None: No Auxiliary contact |
| | 1B: SPST-NC (Form B) |

Application Examples

- EV Charging Station
- Inverter for Solar and Energy Storage
- Uninterruptible Power Supply

Ordering Information

Type	Contact form	Enclosure rating	Terminal shape	Model	Rated coil voltage (V)	Minimum packing unit
Standard	4PST-NO (4a)	Flux protection	PCB terminals	G9KC-4A	12 VDC	45 pcs/box
	4PST-NO (4a) + SPST-NC (1b)			G9KC-4A1B	24 VDC	

Note: When ordering, add the rated coil voltage to the model number.

Example: G9KC-4A DC12

□□ Rated coil voltage

Both the coil voltage on the product case and the packing will be marked as □□ VDC.

Ratings

●Coil

Item	Rated current (mA)	Coil resistance (Ω)	Must operate voltage (V)	Must release voltage (V)	Max. voltage (V)	Power consumption (mW)
Rated voltage			% of rated voltage			
12 VDC	Approx. 417	28.8	75% max.	5% min.	110%	Approx. 5,000 Approx. 613 *1
24 VDC	Approx. 208	115				

Note: 1. The rated current and resistance are measured at a coil temperature of 23°C with a tolerance of ±10%.

Note: 2. The operation characteristic are measured at a coil temperature of 23°C.

Note: 3. The maximum permissible voltage is the maximum value of the fluctuation range of the relay coil operating power supply and was measured at an ambient temperature of 23°C.

Note: 4. Use this relay with coil voltage reduction.

*1. Power consumption with holding voltage is approx. 613 mW (when applying holding voltage at 35%). Please confirm the details on *Coil Voltage Reduction (holding voltage) after Relay Operation* on page 6.

●Contacts

Item		G9KC-4A	G9KC-4A1B
Contact type	Main contact	Double break	
	Auxiliary contact	---	Single break
Contact material	Main contact	Ag Alloy (Cd free)	
	Auxiliary contact	---	Ag + Au plating
Rated load (resistive)	Main contact	480VAC 40A / 277VAC 32A	
	Auxiliary contact	---	1 A at 277 VAC, 1 A at 30 VDC
Rated carry current	Main contact	40 A	
	Auxiliary contact	---	1 A
Max. switching voltage	Main contact	480 VAC	
	Auxiliary contact	---	277 VAC, 30 VDC
Max. switching current	Main contact	40 A	
	Auxiliary contact	---	1 A

Characteristics

Item		G9KC-4A, G9KC-4A1B
Contact resistance *1		Main contact: 6 mΩ max. (Refer to <i>Engineering Data</i> on page 3.) Auxiliary contact: 100 mΩ max.
Operate time *2		50 ms max.
Release time *2		30 ms max.
Insulation resistance *3		1,000 MΩ min.
Dielectric strength	Between coil and contacts	Between coil & main contacts: 5,000 VAC, 50/60 Hz for 1 min Between coil & auxiliary contact: 2,000 VAC, 50/60 Hz for 1 min
	Between contacts of the same polarity	Between open main contacts: 2,000 VAC, 50/60 Hz for 1 min Between open auxiliary contacts: 1,000 VAC, 50/60 Hz for 1min
	Between contacts of different polarity	Between main contact sets: 5,000 VAC, 50/60 Hz for 1 min Between main contact and auxiliary contact: 5,000 VAC, 50/60 Hz for 1 min
Impulse withstand voltage	Between coil and contacts	Main contact: 10 kV (1.2 x 50 μs) Auxiliary contact: 2.5 kV (1.2 x 50 μs)
Vibration resistance	Destruction	10 to 55 to 10 Hz, 0.5 mm single amplitude (1.0 mm double amplitude)
	Malfunction	Excitation: 10 to 55 to 10 Hz, 0.15 mm single amplitude (0.3 mm double amplitude)
Shock resistance	Destruction	735 m/s ²
	Malfunction	Excitation: 25 m/s ²
Durability	Mechanical	G9KC-4A: 1,000,000 operations min (at 10,800 operations/h) G9KC-4A1B: 100,000 operations min (at 10,800 operations/h)
	Electrical (Resistive) *4	Main contact: 32 A at 277 VAC 50,000 operations min. 40 A at 480 VAC 30,000 operations min. Auxiliary contact: 1 A at 277 VAC 100,000 operations min. 1 A at 30 VDC 100,000 operations min. (Switching frequency: 1 second ON - 9 seconds OFF)
Failure rate (M level) (Reference value) *5		Main contact: 100 mA at 24 VDC Auxiliary contact: 10 mA at 5 VDC
Use conditions	Coil holding voltage *6	35% to 50% of rated coil voltage
	Ambient operating temperature	-40°C to 85°C (with no icing or condensation)
	Ambient operating humidity	5% to 85% RH
Weight		Approx. 220 g

Note: The values given above are initial values at 23°C.

*1. Measurement conditions: The main contact complies with the 5 VDC, 40 A (after 3 minutes) voltage drop method, and the auxiliary contact complies with the 5 VDC, 1 A voltage drop method.

*2. Measurement conditions: Applied rated coil voltage, no contact bouncing.

*3. Measurement conditions: Measured with a 500 VDC megohmmeter at the same point as the dielectric strength was measured.

*4. Dielectric strength after electrical durability test

Between coil & main contacts: 5,000 VAC 50/60 Hz for 1 min

Between coil & auxiliary contact: 2,000 VAC 50/60 Hz for 1 min

Between open main contacts: 1,500 VAC 50/60 Hz for 1 min

Between open auxiliary contacts: 700 VAC 50/60 Hz for 1 min

Between main contact sets: 2,000 VAC 50/60 Hz for 1 min

Between main contact and auxiliary contact: 2,000 VAC 50/60Hz for 1 min

*5. The value was measured at a switching frequency of 180 operations/minute.

*6. For the detail regarding holding voltage usage, please refer to *Coil Voltage Reduction (holding voltage) after Relay Operation* on page 6.

Engineering Data

● Contact resistance

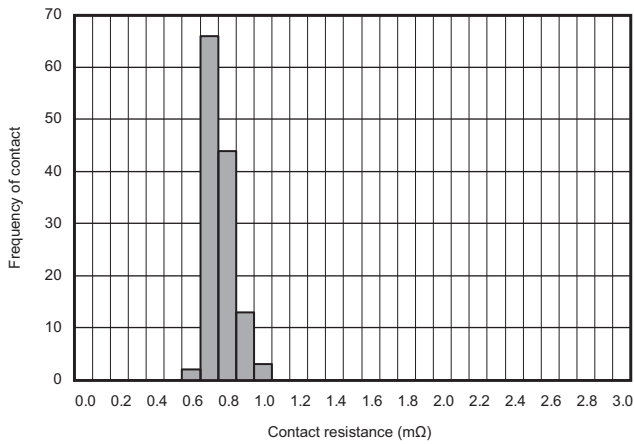

● Malfunction shock resistance

G9KC-4A

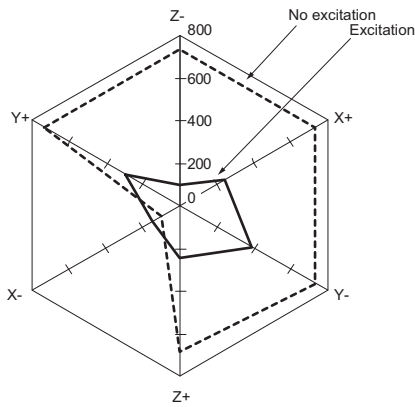

G9KC-4A1B

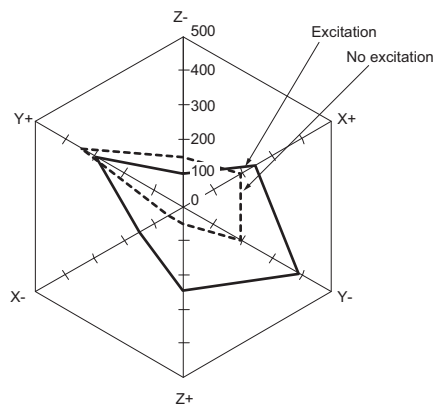

Measurement: Measure the value of contact malfunction happening by applying 3 axes with 6 directions 3 times each.
 The energized voltage is within the range of the rated holding voltage.
 Standard value: Excitation 25 m/s²

Shock direction

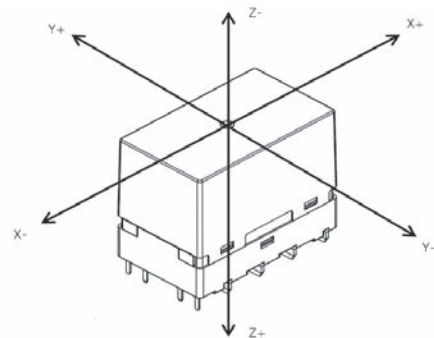

G9KC

Dimensions

CAD Data marked products, 2D drawings and 3D CAD models are available.
For CAD information, please visit our website, which is noted on the last page.

(Unit: mm)

G9KC-4A

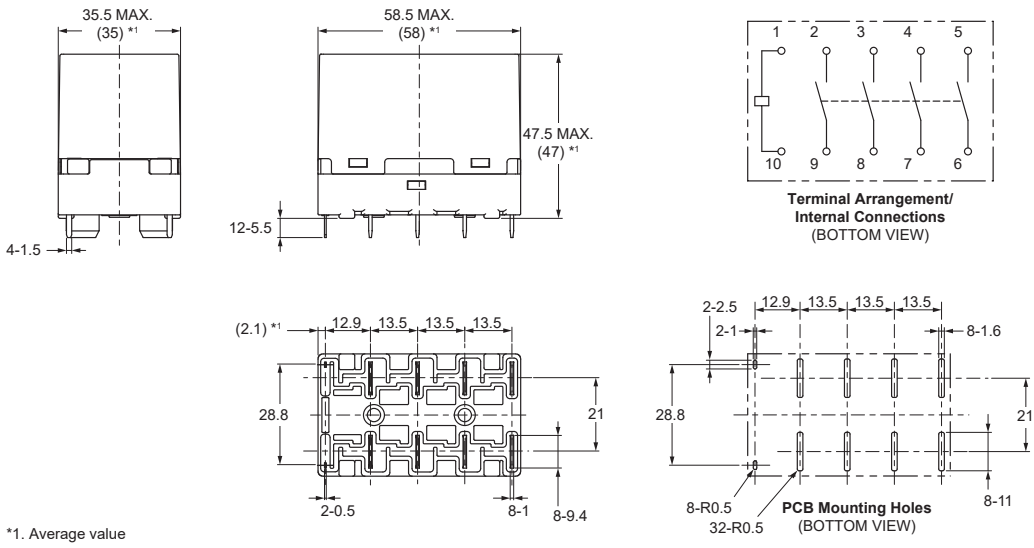

CAD Data

G9KC-4A1B

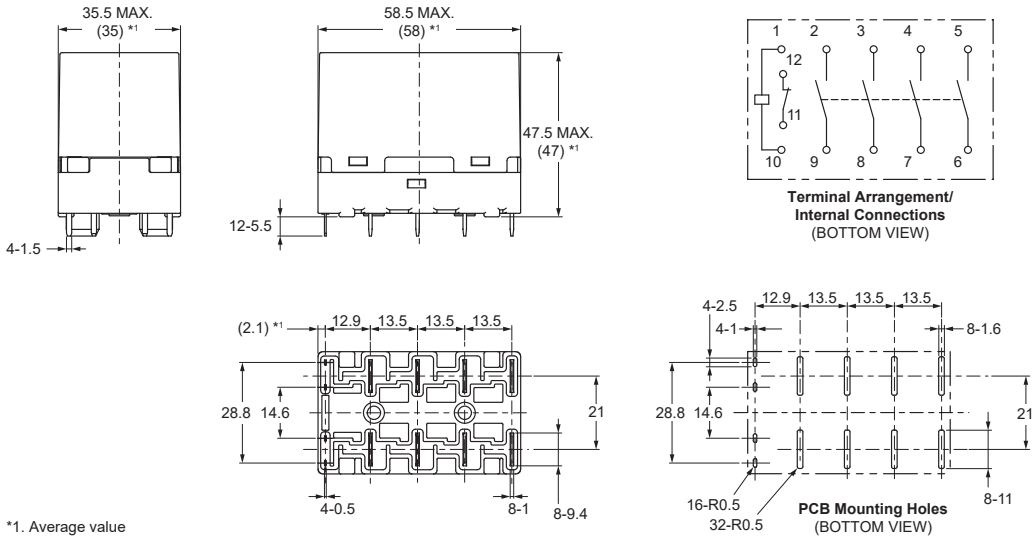

CAD Data

Approval Standard

UL/C-UL Certificated:  (File No. E41515)

Model	Contact form	Coil ratings	Contact ratings	Number of test operations
G9KC-4A	4a	12, 24 VDC *1	277 VAC 32 A (Resistive) 85°C	50,000
			277 VAC 40 A (Resistive) 85°C	30,000
G9KC-4A1B	4a	12, 24 VDC *1	277 VAC 32 A (Resistive) 85°C	50,000
			277 VAC 40 A (Resistive) 85°C	30,000
	1b	12, 24 VDC *1	277 VAC 1 A (Resistive) 85°C	100,000
			30 VDC 1 A (Resistive) 85°C	100,000

*1. Holding voltage of 35% (after applying rated voltage to coil for 0.1 seconds)

EN/IEC, TÜV Certificated:  (Certificate No. R50624494)

Model	Contact form	Coil ratings	Contact ratings	Number of test operations
G9KC-4A	4a	12, 24 VDC *1	277 VAC 32 A (Resistive) 85°C	50,000
			480 VAC 40 A (Resistive) 85°C	30,000
G9KC-4A1B	4a	12, 24 VDC *1	277 VAC 32 A (Resistive) 85°C	50,000
			480 VAC 40 A (Resistive) 85°C	30,000
	1b	12, 24 VDC *1	277 VAC 1 A (Resistive) 85°C	100,000
			30 VDC 1 A (Resistive) 85°C	100,000

*1. Holding voltage of 35% (after applying rated voltage to coil for 0.1 seconds)

CQC Certificated:  (Certificate No. CQC24002430461)

Model	Contact form	Coil ratings	Contact ratings	Number of test operations
G9KC-4A	4a	12, 24 VDC *1	277 VAC 32 A (Resistive) 85°C	50,000
			480 VAC 40 A (Resistive) 85°C	30,000
G9KC-4A1B	4a	12, 24 VDC *1	277 VAC 32 A (Resistive) 85°C	50,000
			480 VAC 40 A (Resistive) 85°C	30,000
	1b	12, 24 VDC *1	277 VAC 1 A (Resistive) 85°C	100,000
			30 VDC 1 A (Resistive) 85°C	100,000

*1. Holding voltage of 35% (after applying rated voltage to coil for 0.1 seconds)

Creepage distance (requirement value)	8 mm min. (Between main contacts and coil)	
Clearance (requirement value)	6.3 mm min. (Between main contacts and coil)	
Insulation material group	IIIa	
Type of insulation	between contacts and coil	Basic (480 V, OV-cat.III, Pollution degree 3) (Main contact)
	between open contacts	Micro disconnection at 480 V and Full disconnection at 277 V (Main contact)
Rated insulation system	277 V / 480 V (Main contact)	
Rated voltage system	277 V / 480 V (Main contact)	
Category of protection (IEC61810-1)	RTII	
Flammability class (UL94)	V-0	
Coil insulation system (UL)	Class F	

Compliant Standard

IEC62955:2018

Main contact: 9.11.2.3 a) + 9.11.2.2

Main contact: 9.11.2.3 b) + 9.11.2.3 c)

$I_p = 2.6 \text{ kA}$, $I^2t = 6.5 \text{ kA}^2\text{s}$ ($I_n \leq 32 \text{ A}$, I_{nc} and $I_{\Delta c} = 10 \text{ kA}$)

$I_m = 500 \text{ A}$, $U = 277/480 \text{ VAC}$

Precautions

● Please refer to "Safety Precautions for All PCB Relays" for correct use.

Warning

As this relay is a high-voltage and high-current type, there is a risk of abnormal heat generation, smoke generation or fire if you use the relay with a contact voltage, current, or for a number of times beyond the specified range. Use only within the specified ranges.



If the power is switched on when the connections are insufficient, there is a risk of abnormal heat generation. Do not connect and use clips and sockets on individual relays.



If the power is switched on when the connections are insufficient, there is a risk of abnormal heat generation. Please install and use relays under recommended conditions.



Precautions for Safe Use

● Drop

- Do not use relays that have been dropped as they may not function properly.

Precautions for Correct Use

● Coil Voltage Reduction (holding voltage) after Relay Operation

- Use this relay with coil voltage reduction.
- Apply the rated voltage for 0.1 to 3 seconds to the coil first.
- The range of coil rated voltage must be set as 100 to 110%, and holding voltage must be 35 to 50%. Do not exceed the ranges due to the change of coil voltage change and so on.

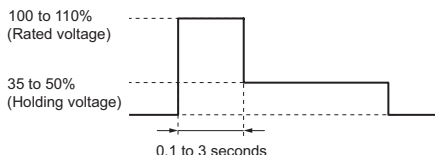

	Applied coil voltage	Coil resistance *	Coil power consumption
Rated voltage	100 to 110%	28.8 Ω (DC12)	Approx. 5 to 6 W
Holding voltage	35 to 50%	115 Ω (DC24)	Approx. 0.6 to 1.3 W

* The coil resistances were measured at a coil temperature of 23°C with tolerances of ± 10%.

● Diode Connection for Operating Coil

- The coil has no polarity. Connect the diodes in the reverse polarity of the voltage applied to the coil.
- Use diodes with a reverse withstand voltage of 10 times or more than the coil rated voltage, and a forward current of at least the coil rated current.

● PCB Terminal Soldering

- Perform soldering under the following conditions.
 - Solder bath
Conduct at 280°C for 20 seconds or less.
 - Flow solder mounting
Mount using the following temperature profile.

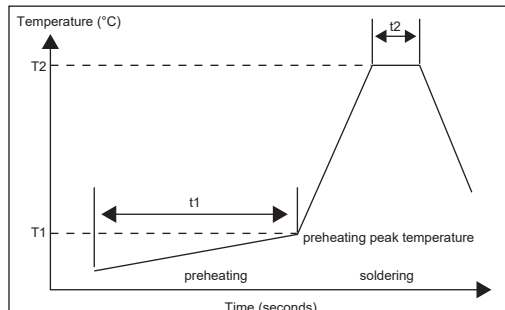

T1 preheating peak temperature (°C)	T2 soldering temperature (°C)	t1 preheating time	t2 soldering time
120	260	40 s or less.	5 s or less.

- It is not possible to wash relay as this is not fully sealed type.

● Assembly

- Assemble relays in an environment with less amount of dust and harmful gases.
- Using the relay under high temperature, high humidity, or harmful gas may deteriorate its performance characteristics due to condensation or corrosive materials, resulting in failure or burn damage to the relay.
- This product weight is about 220 g. Be careful of the strength of PCB. To reduce soldering crack due to heat stress, use both sides through hole PCB.

● Electrical Endurance

- This relay's electrical endurance specification is based on our company's standard test procedure with resistive loads. Relays intended for use with remove; types of drive circuits PWM, capacitive, resistive dropper etc.), types of loads (e.g. capacitive or inductive), and switching cycles (duty and operation timing) must be tested to confirm suitability to the actual intended application.
- The final failure mode is failure to break the circuit. In such a case, burning may extend to surrounding components. Implement safety circuits and other measures to minimize the risk of mechanical failure.

● Micro Load

- The main contact of the relay is suitable for high capacity opening and closing applications. Do not use it for opening and closing of minor loads, such as for signal applications.

Please check each region's Terms & Conditions by region website.

OMRON Corporation

Device & Module Solutions Company

Regional Contact

Americas

<https://components.omron.com/us>

Asia-Pacific

<https://components.omron.com/ap>

Korea

<https://components.omron.com/kr>

Europe

<https://components.omron.com/eu>

China

<https://components.omron.com.cn>

Japan

<https://components.omron.com/jp>