



L29S-3D3430

L29

SAFETY SINGLE-BEAM SENSORS

SICK
Sensor Intelligence.



Ordering information

Scanning range	Housing material	System part	Type	Part no.
6 m	VISTAL®	Sender	L29S-3D3430	2075831

Other models and accessories → www.sick.com/L29



Detailed technical data

Features

Light source	LED
Type of light	Visible red light
Scanning range	6 m
Number of beams	1
Response time	0.54 ms
Response time	0.54 ms + Test device response time (Flexi Classic)

Safety-related parameters

Type	Type 2 (IEC 61496-1) ¹⁾
Safety integrity level	SIL 1 (IEC 61508) ¹⁾
Category	Category 2 (EN ISO 13849) ¹⁾
Test rate (external test)	100 /s (EN ISO 13849) ²⁾
Maximum demand rate	≤ 60 min ⁻¹ (EN ISO 13849) ³⁾
Performance level	PL c (EN ISO 13849) ¹⁾
PFH_D (mean probability of a dangerous failure per hour)	1.0 x 10 ⁻⁶ (EN ISO 13849) ¹⁾
T_M (mission time)	20 years (EN ISO 13849)

¹⁾ Only in conjunction with Flexi Classic (UE410-MU).

²⁾ The test rate shall not be exceeded.

³⁾ Between two requirements on a safety-related response of the device, at least 100 internal or external tests must be carried out.

Interfaces

Connection type	Male connector M12, 4-pin
Length of cable	120 mm
Permitted cable length	≤ 30 m
Display elements	LED

Electrical data

Protection class	III (IEC 61140)
Supply voltage V_s	24 V DC (19.2 V DC ... 30 V DC)
Power consumption	≤ 30 mA

Mechanical data

Design	Rectangular
Dimensions (W x H x D)	12.2 mm x 50 mm x 23.6 mm
Housing material	VISTAL®
Weight	+ 80 g

Ambient data

Enclosure rating	IP65 (IEC 60529) IP66 (IEC 60529) IP67 (IEC 60529) IP69K (ISO 20653)
Ambient operating temperature	-40 °C ... +60 °C
Storage temperature	-40 °C ... +75 °C
Air humidity	15 % ... 95 %, Non-condensing
Vibration resistance	5 g, 10 Hz ... 55 Hz (IEC 60068-2-6)
Shock resistance	10 g, 16 ms (IEC 60068-2-29)

Other information

Light source	LED
Type of light	Visible red light
Wave length	650 nm
Light spot diameter (distance)	25 mm (1 m)
Average service life (T_A)	100,000 h (+25 °C)
Aperture angle/receiving angle	± 5° / ± 5°

Classifications

ECLASS 5.0	27272701
ECLASS 5.1.4	27272701
ECLASS 6.0	27272701
ECLASS 6.2	27272701
ECLASS 7.0	27272701
ECLASS 8.0	27272701
ECLASS 8.1	27272701
ECLASS 9.0	27272701
ECLASS 10.0	27272701
ECLASS 11.0	27272701
ECLASS 12.0	27272701
ETIM 5.0	EC001831
ETIM 6.0	EC001831
ETIM 7.0	EC001831

ETIM 8.0	EC001831
UNSPSC 16.0901	46171620

Dimensional drawing (Dimensions in mm (inch))

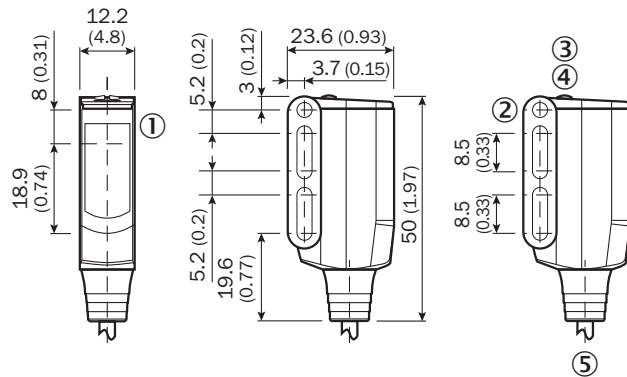

- ① Optical axis, sender and receiver
- ② Mounting hole \varnothing 3.1 mm
- ③ LED indicator yellow: Status of received light beam
- ④ LED indicator green: Supply voltage active
- ⑤ Cable with M12 male connector, 4-pin

Recommended accessories

Other models and accessories → www.sick.com/L29

Brief description	Type	Part no.
Plug connectors and cables		
 <ul style="list-style-type: none"> • Connection type head A: Female connector, M12, 4-pin, straight, A-coded • Connection type head B: Flying leads • Signal type: Sensor/actuator cable • Cable: 5 m, 4-wire, PVC • Description: Sensor/actuator cable, unshielded • Application: Zones with chemicals 	YF2A14-050VB3XLEAX	2096235

SICK AT A GLANCE

SICK is one of the leading manufacturers of intelligent sensors and sensor solutions for industrial applications. A unique range of products and services creates the perfect basis for controlling processes securely and efficiently, protecting individuals from accidents and preventing damage to the environment.

We have extensive experience in a wide range of industries and understand their processes and requirements. With intelligent sensors, we can deliver exactly what our customers need. In application centers in Europe, Asia and North America, system solutions are tested and optimized in accordance with customer specifications. All this makes us a reliable supplier and development partner.

Comprehensive services complete our offering: SICK LifeTime Services provide support throughout the machine life cycle and ensure safety and productivity.

For us, that is “Sensor Intelligence.”

WORLDWIDE PRESENCE:

Contacts and other locations –www.sick.com