

Current Transducer FL-SDxlxx series

$I_{PN} = 12000 \text{ A} \dots 28000 \text{ A}$

Ref: FL 12000-SDxlxx, FL 16000-SDxlxx, FL 20000-SDxlxx, FL 24000-SDxlxx,
FL 28000-SDxlxx

For the electronic measurement of current: DC, AC, pulsed..., with galvanic separation between the primary and the secondary circuit.



Features

- Hall effect Open Loop Coreless Integral current transducer
- Uni- or Bi-polar ¹⁾ measurement of primary current up to 42 kA
- Instantaneous 4-20 mA current output
- Power supply +12 or +24 V DC
- Galvanic separation between primary and secondary circuit
- Factory calibrated.

Advantages

- Wide measurement range
- 2 aperture widths: 200 and 300 mm
- No magnetic offset
- Low consumption and low losses
- Wide range of rectangular busbar dimensions
- Light weight design
- M12 field connector.

Applications

- Wind turbine power converter
- Electrolyser
- High power drives.

Standards

- IEC 62477-1: 2022
- IEC 61800-5-1: 2022
- IEC 62109-1: 2010
- IEC 61010-1: 2010
- EN 50155: 2021
- IEC 61992-7-2: 2006
- UL 61010-1: 3ED 2022.

Application Domains

- Industrial
- Trackside.

Note: ¹⁾ see references on [page 11](#).

Safety



Caution

If the device is used in a way that is not specified by the manufacturer, the protection provided by the device may be compromised. Always inspect the electronics unit and connecting cable before using this product and do not use it if damaged. Mounting assembly shall guarantee the maximum primary conductor temperature, fulfill clearance and creepage distance, minimize electric and magnetic coupling, and unless otherwise specified can be mounted in any orientation.



Caution, risk of electrical shock

This transducer must be used in limited-energy secondary circuits SELV according to IEC 61010-1, in electric/electronic equipment with respect to applicable standards and safety requirements in accordance with the manufacturer's operating specifications.

Use caution during installation and use of this product; certain parts of the module can carry hazardous voltages and high currents (e.g. power supply, primary conductor).

Ignoring this warning can lead to injury and and/or cause serious damage.

De-energize all circuits and hazardous live parts before installing the product.

All installations, maintenance, servicing operations and use must be carried out by trained and qualified personnel practicing applicable safety precautions.

This transducer is a build-in device, whose hazardous live parts must be inaccessible after installation.

This transducer must be mounted in a suitable end-enclosure.

Main supply must be able to be disconnected.

Never connect or disconnect the external power supply while the primary circuit is connected to live parts.

Always wear protective clothing and gloves if hazardous live parts are present in the installation where the measurement is carried out.

This transducer is a built-in device, not intended to be cleaned with any product. Nevertheless if the user must implement cleaning or washing process, validation of the cleaning program has to be done by himself.

Do not dispose of this product as unsorted municipal waste.

Contact a qualified recycler for disposal.

Absolute maximum ratings

Parameter	Symbol	Unit	Value
Maximum supply voltage (not destructive)	$\pm U_{C\max}$	V	-0.3 ... 32 V DC
Maximum primary conductor temperature	$T_{B\max}$	°C	105
Electrostatic discharge voltage (HBM - Human Body Model)	$U_{ESD\ HBM}$	kV	2

Stresses above these ratings may cause permanent damage.
Exposure to absolute maximum ratings for extended periods may degrade reliability.

Insulation coordination

Parameter	Symbol	Unit	Value	Comment
RMS voltage for AC insulation test, 50 Hz, 1 min	U_d	kV	12	
Impulse withstand voltage 1.2/50 μ s	U_{Ni}	kV	44	Target, TBC
RMS voltage for AC insulation routine test, 50 Hz, 2"		kV	5.3	Industry application ¹⁾
RMS voltage for AC insulation routine test, 50 Hz, 5"		kV	18.5	Traction application ¹⁾
Partial discharge RMS type test voltage ($q_m < 10$ pC)	U_t	V	2480	Primary/Secondary Industry application ^{1) 2)}
Partial discharge RMS type test voltage ($q_m < 10$ pC)	U_t	V	4840	Primary/Secondary Traction application ^{1) 2)}
Minimum clearance (pri. - sec.)	d_{Cl}	mm	> 72	Shortest distance through air
Minimum creepage distance (pri. - sec.)	d_{Cp}	mm	> 100	Shortest path along device body
Case material	-	-	V0	According to UL 94
Comparative tracking index	<i>CTI</i>		600	
Application example Industry Working voltage		V	1500	Reinforced insulation non-uniform According to: IEC 61800-5-1, CAT III PD2 IEC 61010-1, CAT IV PD3 IEC 62477-1, CAT IV PD3
Application example Trackside/Traction Nominal voltage Rated insulation voltage	U_N U_{Nm}	V	3000 3600/3700	Reinforced insulation non-uniform According to: IEC 62497-1, CAT III PD3

Environmental and mechanical characteristics

Parameter	Symbol	Unit	Min	Typ	Max	Comment
Ambient operating temperature	T_A	°C	-40		+85	
Ambient storage temperature	$T_{A\ st}$	°C	-40		+90	
Mass	m	g		1180 1320		- SDxlx200 - SDxlx300

- Notes:** ¹⁾ See reference table on [page 11](#)
²⁾ Guaranteed with a centered busbar of 200 (300) x 100 mm maximum dimension with an edge chamfer of 1.5 mm or any other shape and layout providing a minimum clearance of 3 mm between the bare metal and the inner wall of the transducer.

Electrical data FL 12000-SDx1x200

 At $T_A = 25\text{ °C}$, $U_C = +24\text{ V}$, $R_M = 100\text{ }\Omega$, unless otherwise noted (see Min, Max, typ, definition paragraph in [page 9](#)).

Parameter		Symbol	Unit	Min	Typ	Max	Comment
Primary nominal current		I_{PN}	A		12000		See ¹⁾
Primary current, measuring range		I_{PM}	A	-18000 0		18000 18000	SDB1x version SDU1x version
Supply voltage		U_C	V	10		28	See ²⁾
Current consumption	SDxx200	I_C	mA		$200 + 1.2 \times I_{out}$ $100 + 1.2 \times I_{out}$	240 120	@ $U_C = 12\text{ V DC}$ @ $U_C = 24\text{ V DC}$
	SDxx300				$240 + 1.2 \times I_{out}$ $120 + 1.2 \times I_{out}$	280 140	@ $U_C = 12\text{ V DC}$ @ $U_C = 24\text{ V DC}$
Output current range		I_{out}	mA	4		20	SDB1x version $I_{out} = 12\text{ mA @ } I_p = 0$ SDUx version $I_{out} = 4\text{ mA @ } I_p = 0$
Measuring resistance range		R_M	Ω	10	100	240	
Electrical offset current referred to primary		I_{OE}	A	-27		27	
Nominal sensitivity		S_N	mV/A		0.444 0.889		SDB1x version SDU1x version
Magnetic offset current (@ I_{PN}) referred to primary		I_{OM}	A		none		No magnetic core inside, OLCI technology
Sensitivity error @ I_{PN}		ϵ_S	%	-0.15		0.15	Factory adjustment
Linearity error 0 ... I_{PM}		ϵ_L	% of I_{PM}	-0.35		0.35	
Temperature coefficient of I_{OE} ³⁾		TCl_{OE}	A/K	-2.7 -1.8		2.7 1.8	-40 °C ... +25 °C +25 °C ... +85 °C
Temperature coefficient of S		TCS	ppm/K	-120		120	-40 °C ... +85 °C
Sum of sensitivity & Linearity error 0 ... I_{PM}		ϵ_{SL}	% of I_{PM}	-0.5		0.5	Primary busbar centered No return busbar considered ⁴⁾
Total error @ 25 °C @ $I_p = 0$ @ $I_p = \pm I_{PM}$		ϵ_{tot}	% of I_{PM}	-0.15 -0.65		0.15 0.65	Primary busbar centered No return busbar considered ⁴⁾
Total error @ -40 °C @ $I_p = 0$ @ $I_p = \pm I_{PM}$		ϵ_{tot}	% of I_{PM}	-0.99 -1.55		0.99 1.55	Primary busbar centered No return busbar considered ⁴⁾
Total error @ 85 °C @ $I_p = 0$ @ $I_p = \pm I_{PM}$		ϵ_{tot}	% of I_{PM}	-0.62 -1.25		0.62 1.25	Primary busbar centered No return busbar considered ⁴⁾
Delay time @ 10 % of the final output value I_{PN} step		t_{D10}	μs			2.5	@ 100 A/ μs
Delay time @ 90 % of the final output value I_{PN} step		t_{D90}	μs			2.5	@ 100 A/ μs
Frequency bandwidth (-3 dB)		BW	kHz		100		
Noise current spectral density referred to primary 100 Hz ... 100 kHz 100 kHz ... 1 MHz		i_{no}	mA/ $\sqrt{\text{Hz}}$		TBD		
RMS noise current spectral density referred to primary: up to 10 kHz up to 100 kHz up to 1 MHz		I_{no}	mA		TBD		

- Notes:**
- ¹⁾ This low power coreless transducer may accept up to I_{Pmax} permanent current; at the only condition of respecting the maximum primary conductor temperature (105 °C)
 - ²⁾ Above 28 V, accuracy performance may change irremediably
 - ³⁾ Rounded, actual value is obtained by the following formula: $12\text{ mA} \pm I_{PM} \times S_N$ or $4\text{ mA} + I_{PM} \times S_N$
 - ⁴⁾ See [page 10](#) typical influence of the return busbar regarding its position.

Electrical data FL 16000-SDx1x200

 At $T_A = 25\text{ °C}$, $U_C = +24\text{ V}$, $R_L = 100\ \Omega$, unless otherwise noted (see Min, Max, typ, definition paragraph in [page 9](#)).

Parameter		Symbol	Unit	Min	Typ	Max	Comment
Primary nominal current		I_{PN}	A		16000		See ¹⁾
Primary current, measuring range		I_{PM}	A	-24000 0		24000 24000	SDB1x version SDU1x version
Supply voltage		U_C	V	10		28	See ²⁾
Current consumption	SDxx200	I_C	mA		$200 + 1.2 \times I_{out}$ $100 + 1.2 \times I_{out}$	240 120	@ $U_C = 12\text{ V DC}$ @ $U_C = 24\text{ V DC}$
	SDxx300				$240 + 1.2 \times I_{out}$ $120 + 1.2 \times I_{out}$	280 140	@ $U_C = 12\text{ V DC}$ @ $U_C = 24\text{ V DC}$
Output current range		I_{out}	mA	4		20	SDB1x version $I_{out} = 12\text{ mA @ } I_P = 0$ SDUx version $I_{out} = 4\text{ mA @ } I_P = 0$
Measuring resistance range		R_M	Ω	0	100	240	
Electrical offset current referred to primary		I_{OE}	A	-36		36	
Nominal sensitivity		S_N	mV/A		0.333 0.667		SDB1x version SDU1x version
Magnetic offset current (@ I_{PN}) referred to primary		I_{OM}	A		none		No magnetic core inside, OLCI technology
Sensitivity error @ I_{PN}		ε_S	%	-0.15		0.15	Factory adjustment
Linearity error 0 ... I_{PM}		ε_L	% of I_{PM}	-0.35		0.35	
Temperature coefficient of U_{ref}		TCU_{ref}	ppm/K	-80		80	-40 °C ... +85 °C
Temperature coefficient of I_{OE} ³⁾		TCI_{OE}	A/K	-3.6 -2.4		3.6 2.4	-40 °C ... +25 °C +25 °C ... +85 °C
Temperature coefficient of S		TCS	ppm/K	-120		120	-40 °C ... +85 °C
Sum of sensitivity & Linearity error 0 ... I_{PM}		ε_{SL}	% of I_{PM}	-0.5		0.5	Primary busbar centered No return busbar considered ⁴⁾
Total error @ 25 °C @ $I_P = 0$ @ $I_P = \pm I_{PM}$		ε_{tot}	% of I_{PM}	-0.15 -0.65		0.15 0.65	Primary busbar centered No return busbar considered ⁴⁾
Total error @ -40 °C @ $I_P = 0$ @ $I_P = \pm I_{PM}$		ε_{tot}	% of I_{PM}	-0.99 -1.55		0.99 1.55	Primary busbar centered No return busbar considered ⁴⁾
Total error @ 85 °C @ $I_P = 0$ @ $I_P = \pm I_{PM}$		ε_{tot}	% of I_{PM}	-0.62 -1.25		0.62 1.25	Primary busbar centered No return busbar considered ⁴⁾
Delay time @ 10 % of the final output value I_{PN} step		t_{D10}	μs			2.5	@ 100 A/ μs
Delay time @ 90 % of the final output value I_{PN} step		t_{D90}	μs			2.5	@ 100 A/ μs
Frequency bandwidth (-3 dB)		BW	kHz		100		
Noise current spectral density referred to primary 100 Hz ... 100 kHz 100 kHz ... 1 MHz		i_{no}	mA/ $\sqrt{\text{Hz}}$		TBD		
RMS noise current spectral density referred to primary: up to 10 kHz up to 100 kHz up to 1 MHz		I_{no}	mA		TBD		

Notes: ¹⁾ This low power coreless transducer may accept up to $I_{P\text{max}}$ permanent current; at the only condition of respecting the maximum primary conductor temperature (105 °C)

²⁾ Above 28 V, accuracy performance may change irremediably

³⁾ Rounded, actual value is obtained by the following formula: $\pm I_{PM} \times S_N$

⁴⁾ See [page 10](#) typical influence of the return busbar regarding its position.

Electrical data FL 20000-SDx1x200

 At $T_A = 25\text{ °C}$, $U_C = +24\text{ V}$, $R_L = 100\text{ }\Omega$, unless otherwise noted (see Min, Max, typ, definition paragraph in [page 9](#)).

Parameter		Symbol	Unit	Min	Typ	Max	Comment
Primary nominal current		I_{PN}	A		20000		See ¹⁾
Primary current, measuring range		I_{PM}	A	-30000 0		30000 30000	SDBIx version SDUIx version
Supply voltage		U_C	V	10		28	See ²⁾
Current consumption	SDxx200	I_C	mA		$200 + 1.2 \times I_{out}$ $100 + 1.2 \times I_{out}$	240 120	@ $U_C = 12\text{ V DC}$ @ $U_C = 24\text{ V DC}$
	SDxx300				$240 + 1.2 \times I_{out}$ $120 + 1.2 \times I_{out}$	280 140	@ $U_C = 12\text{ V DC}$ @ $U_C = 24\text{ V DC}$
Output current range		I_{out}	mA	4		20	SDBIx version $I_{out} = 12\text{ mA @ } I_P = 0$ SDUIx version $I_{out} = 4\text{ mA @ } I_P = 0$
Measuring resistance range		R_M	Ω	0	120	240	
Electrical offset current referred to primary		I_{OE}	A	-45		45	
Nominal sensitivity		S_N	mV/A		0.267 0.533		SDBIx version SDUIx version
Magnetic offset current (@ I_{PN}) referred to primary		I_{OM}	A		none		No magnetic core inside, OLCI technology
Sensitivity error @ I_{PN}		ε_S	%	-0.15		0.15	Factory adjustment
Linearity error 0 ... I_{PM}		ε_L	% of I_{PM}	-0.35		0.35	
Temperature coefficient of I_{OE} ³⁾		TCI_{OE}	A/K	-4.5 -3		4.5 3	-40 °C ... +25 °C +25 °C ... +85 °C
Temperature coefficient of S		TCS	ppm/K	-120		120	-40 °C ... +85 °C
Sum of sensitivity & Linearity error 0 ... I_{PM}		ε_{SL}	% of I_{PM}	-0.5		0.5	Primary busbar centered No return busbar considered ⁴⁾
Total error @ 25 °C @ $I_P = 0$ @ $I_P = \pm I_{PM}$		ε_{tot}	% of I_{PM}	-0.15 -0.65		0.15 0.65	Primary busbar centered No return busbar considered ⁴⁾
Total error @ -40 °C @ $I_P = 0$ @ $I_P = \pm I_{PM}$		ε_{tot}	% of I_{PM}	-0.99 -1.55		0.99 1.55	Primary busbar centered No return busbar considered ⁴⁾
Total error @ 85 °C @ $I_P = 0$ @ $I_P = \pm I_{PM}$		ε_{tot}	% of I_{PM}	-0.62 -1.25		0.62 1.25	Primary busbar centered No return busbar considered ⁴⁾
Delay time @ 10 % of the final output value I_{PN} step		t_{D10}	μs			2.5	@ 100 A/ μs
Delay time @ 90 % of the final output value I_{PN} step		t_{D90}	μs			2.5	@ 100 A/ μs
Frequency bandwidth (-3 dB)		BW	kHz		100		
Noise current spectral density referred to primary 100 Hz ... 100 kHz 100 kHz ... 1 MHz		i_{no}	mA/ $\sqrt{\text{Hz}}$		TBD		
RMS noise current spectral density referred to primary: up to 10 kHz up to 100 kHz up to 1 MHz		I_{no}	mA		TBD		

- Notes:**
- ¹⁾ This low power coreless transducer may accept up to I_{Pmax} permanent current; at the only condition of respecting the maximum primary conductor temperature (105 °C)
 - ²⁾ Above 28 V, accuracy performance may change irremediably
 - ³⁾ Rounded, actual value is obtained by the following formula: $\pm I_{PM} \times S_N$
 - ⁴⁾ See [page 10](#) typical influence of the return busbar regarding its position.

Electrical data FL 24000-SDx1x200

 At $T_A = 25\text{ °C}$, $U_C = +24\text{ V}$, $R_L = 100\text{ }\Omega$, unless otherwise noted (see Min, Max, typ, definition paragraph in [page 9](#)).

Parameter		Symbol	Unit	Min	Typ	Max	Comment
Primary nominal current		I_{PN}	A		24000		See ¹⁾
Primary current, measuring range		I_{PM}	A	-36000 0		36000 36000	SDB1x version SDU1x version
Supply voltage		U_C	V	10		28	See ²⁾
Current consumption	SDxx200	I_C	mA		$200 + 1.2 \times I_{out}$ $100 + 1.2 \times I_{out}$	240 120	@ $U_C = 12\text{ V DC}$ @ $U_C = 24\text{ V DC}$
	SDxx300				$240 + 1.2 \times I_{out}$ $120 + 1.2 \times I_{out}$	280 140	@ $U_C = 12\text{ V DC}$ @ $U_C = 24\text{ V DC}$
Output current range		I_{out}	mA	4		20	SDB1x version $I_{out} = 12\text{ mA @ } I_P = 0$ SDUx version $I_{out} = 4\text{ mA @ } I_P = 0$
Measuring resistance range		R_M	Ω	0	120	240	
Electrical offset current referred to primary		I_{OE}	A	-36		36	
Nominal sensitivity		S_N	mV/A		0.222 0.444		SDx version SDUx version
Magnetic offset current (@ I_{PN}) referred to primary		I_{OM}	A		none		No magnetic core inside, OLCI technology
Sensitivity error @ I_{PN}		ε_S	%	-0.15		0.15	Factory adjustment
Linearity error 0 ... I_{PM}		ε_L	% of I_{PM}	-0.35		0.35	
Temperature coefficient of I_{OE} ³⁾		TCI_{OE}	A/K	-5.4 -3.6		5.4 3.6	-40 °C ... +25 °C +25 °C ... +85 °C
Temperature coefficient of S		TCS	ppm/K	-120		120	-40 °C ... +85 °C
Sum of sensitivity & Linearity error 0 ... I_{PM}		ε_{SL}	% of I_{PM}	-0.5		0.5	Primary busbar centered No return busbar considered ⁴⁾
Total error @ 25 °C @ $I_P = 0$ @ $I_P = \pm I_{PM}$		ε_{tot}	% of I_{PM}	-0.15 -0.65		0.15 0.65	Primary busbar centered No return busbar considered ⁴⁾
Total error @ -40 °C @ $I_P = 0$ @ $I_P = \pm I_{PM}$		ε_{tot}	% of I_{PM}	-0.99 -1.55		0.99 1.55	Primary busbar centered No return busbar considered ⁴⁾
Total error @ 85 °C @ $I_P = 0$ @ $I_P = \pm I_{PM}$		ε_{tot}	% of I_{PM}	-0.62 -1.25		0.62 1.25	Primary busbar centered No return busbar considered ⁴⁾
Delay time @ 10 % of the final output value I_{PN} step		t_{D10}	μs			2.5	@ 100 A/ μs
Delay time @ 90 % of the final output value I_{PN} step		t_{D90}	μs			2.5	@ 100 A/ μs
Frequency bandwidth (-3 dB)		BW	kHz		100		
Noise current spectral density referred to primary 100 Hz ... 100 kHz 100 kHz ... 1 MHz		i_{no}	$\text{mA}/\sqrt{\text{Hz}}$		TBD		
RMS noise current spectral density referred to primary: up to 10 kHz up to 100 kHz up to 1 MHz		I_{no}	mA		TBD		

Notes: ¹⁾ This low power coreless transducer may accept up to I_{Pmax} permanent current; at the only condition of respecting the maximum primary conductor temperature (105 °C)

²⁾ Above 28 V, accuracy performance may change irremediably

³⁾ Rounded, actual value is obtained by the following formula: $\pm I_{PM} \times S_N$

⁴⁾ See [page 10](#) typical influence of the return busbar regarding its position.

Electrical data FL 28000-SDx1x200

 At $T_A = 25\text{ °C}$, $U_C = +24\text{ V}$, $R_L = 100\ \Omega$, unless otherwise noted (see Min, Max, typ, definition paragraph in [page 9](#)).

Parameter		Symbol	Unit	Min	Typ	Max	Comment
Primary nominal current		I_{PN}	A		28000		See ¹⁾
Primary current, measuring range		I_{PM}	A	-42000 0		42000 42000	SDBIx version SDUix version
Supply voltage		U_C	V	10		28	See ²⁾
Current consumption	SDxx200	I_C	mA		$200 + 1.2 \times I_{out}$ $100 + 1.2 \times I_{out}$	240 120	@ $U_C = 12\text{ V DC}$ @ $U_C = 24\text{ V DC}$
	SDxx300				$240 + 1.2 \times I_{out}$ $120 + 1.2 \times I_{out}$	280 140	@ $U_C = 12\text{ V DC}$ @ $U_C = 24\text{ V DC}$
Output current range		I_{out}	mA	4		20	SDBIx version $I_{out} = 12\text{ mA @ } I_p = 0$ SDUix version $I_{out} = 4\text{ mA @ } I_p = 0$
Measuring resistance range		R_M	Ω	0	120	240	
Electrical offset current referred to primary		I_{OE}	A	-63		63	
Nominal sensitivity		S_N	mV/A		0.190 0.381		SDBIx version SDUix version
Magnetic offset current (@ I_{PN}) referred to primary		I_{OM}	A		none		No magnetic core inside, OLCI technology
Sensitivity error @ I_{PN}		ε_S	%	-0.15		0.15	Factory adjustment
Linearity error 0 ... I_{PM}		ε_L	% of I_{PM}	-0.35		0.35	
Temperature coefficient of I_{OE} ³⁾		TCl_{OE}	A/K	-6.3 -4.2		6.3 4.2	-40 °C ... +25 °C +25 °C ... +85 °C
Temperature coefficient of S		TCS	ppm/K	-120		120	-40 °C ... +85 °C
Sum of sensitivity & Linearity error 0 ... I_{PM}		ε_{SL}	% of I_{PM}	-0.5		0.5	Primary busbar centered No return busbar considered ⁴⁾
Total error @ 25 °C @ $I_p = 0$ @ $I_p = \pm I_{PM}$		ε_{tot}	% of I_{PM}	-0.15 -0.65		0.15 0.65	Primary busbar centered No return busbar considered ⁴⁾
Total error @ -40 °C @ $I_p = 0$ @ $I_p = \pm I_{PM}$		ε_{tot}	% of I_{PM}	-0.54 -1.25		0.54 1.25	Primary busbar centered No return busbar considered ⁴⁾
Total error @ 85 °C @ $I_p = 0$ @ $I_p = \pm I_{PM}$		ε_{tot}	% of I_{PM}	-0.50 -1.19		0.50 1.19	Primary busbar centered No return busbar considered ⁴⁾
Delay time @ 10 % of the final output value I_{PN} step		t_{D10}	μs			2.5	@ 100 A/ μs
Delay time @ 90 % of the final output value I_{PN} step		t_{D90}	μs			2.5	@ 100 A/ μs
Frequency bandwidth (-3 dB)		BW	kHz		100		
Noise current spectral density referred to primary 100 Hz ... 100 kHz 100 kHz ... 1 MHz		i_{no}	mA/ $\sqrt{\text{Hz}}$		TBD		
RMS noise current spectral density referred to primary: up to 10 kHz up to 100 kHz up to 1 MHz		I_{no}	mA		TBD		

- Notes:**
- ¹⁾ This low power coreless transducer may accept up to I_{Pmax} permanent current; at the only condition of respecting the maximum primary conductor temperature (105 °C)
 - ²⁾ Above 28 V, accuracy performance may change irremediably
 - ³⁾ Rounded, actual value is obtained by the following formula: $\pm I_{PM} \times S_N$
 - ⁴⁾ See [page 10](#) typical influence of the return busbar regarding its position.

Definition of typical, minimum and maximum values

Minimum and maximum values for specified limiting and safety conditions have to be understood as such as well as values shown in “typical” graphs.

On the other hand, measured values are part of a statistical distribution that can be specified by an interval with upper and lower limits and a probability for measured values to lie within this interval.

Unless otherwise stated (e.g. “100 % tested”), the LEM definition for such intervals designated with “min” and “max” is that the probability for values of samples to lie in this interval is 99.73 %.

For a normal (Gaussian) distribution, this corresponds to an interval between -3 sigma and $+3$ sigma. If “typical” values are not obviously mean or average values, those values are defined to delimit intervals with a probability of 68.27 %, corresponding to an interval between $-\sigma$ and $+\sigma$ for a normal distribution.

Typical, maximal and minimal values are determined during the initial characterization of the product.

Typical input/output characteristics

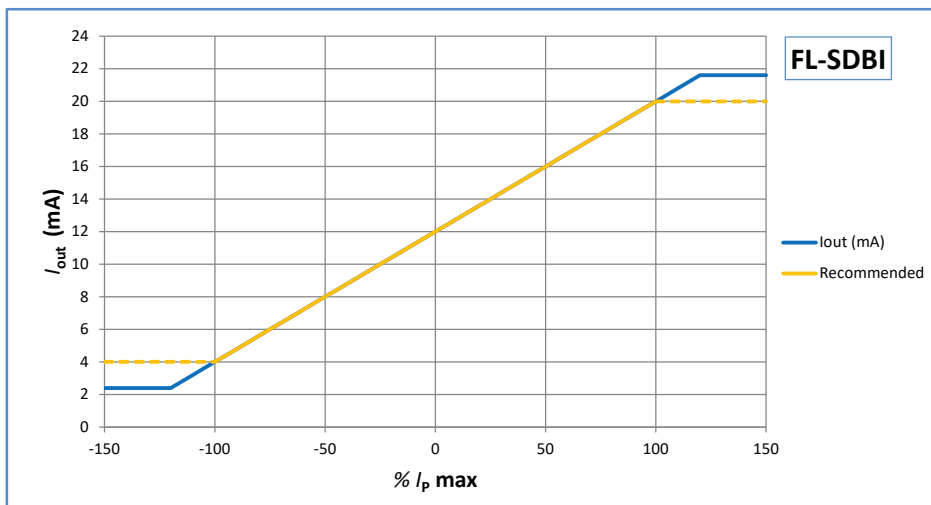

Figure 1: Bi-polar output current I_{out} VS primary current I_p

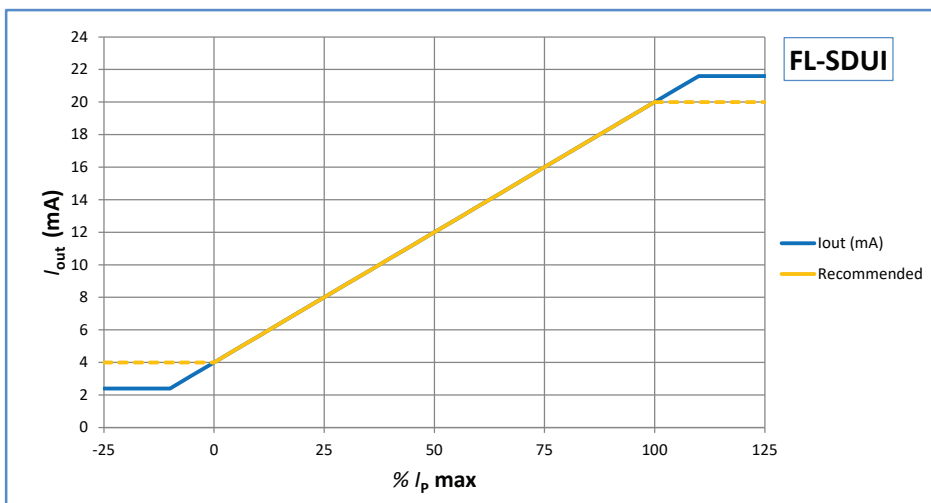
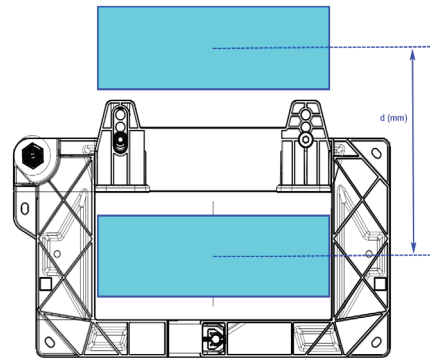
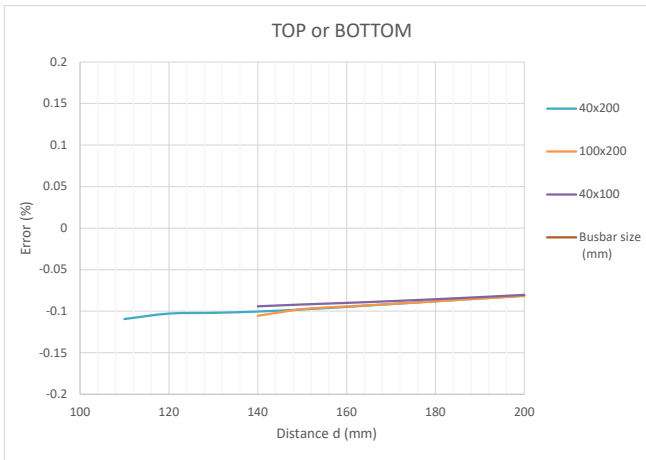
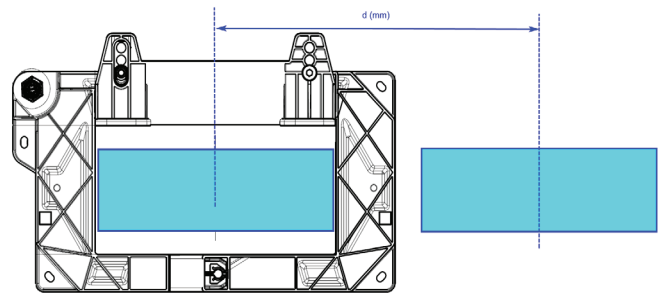
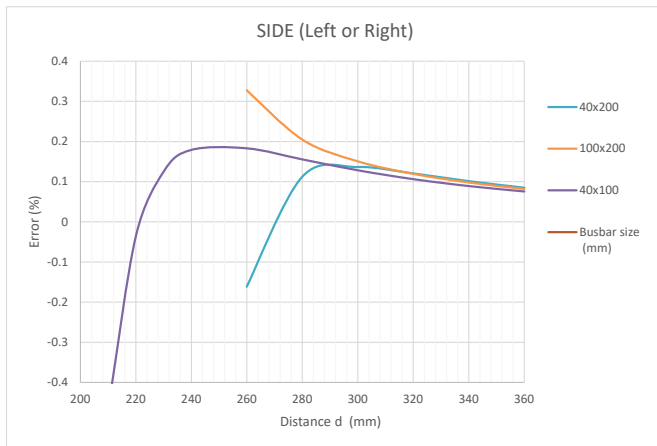

Figure 2: Uni-polar output current I_{out} VS primary current I_p

Typical additional error due to return busbar layout and distance



Busbar on TOP or BOTTOM



Busbar on the side (LEFT or RIGHT)

FL-SDxlxx series: name and codification

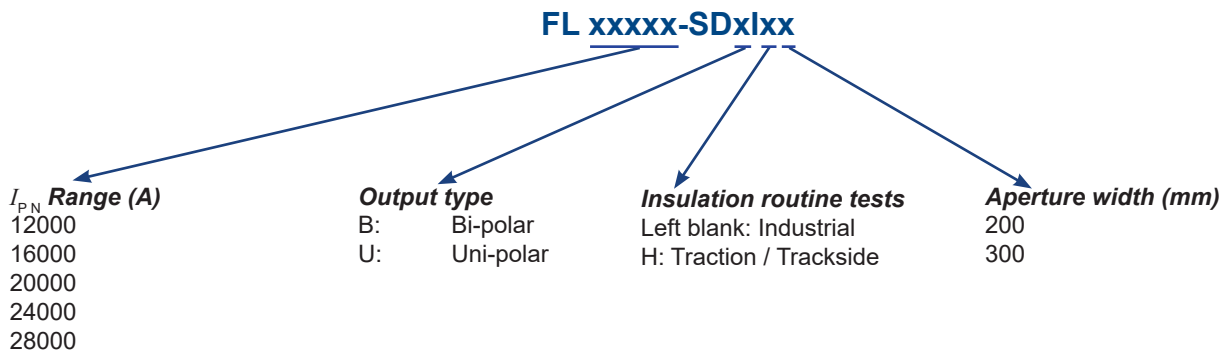

FL-SDxlxx series: ordering ¹⁾

Name	Part numbers	Name	Part numbers
FL 12000-SDBI200	90.Z2.80.001.0	FL 12000-SDBIH200	90.Z2.80.031.0
FL 12000-SDUI200	90.Z2.80.002.0	FL 12000-SDUIH200	90.Z2.80.032.0
FL 16000-SDBI200	90.Z2.82.003.0	FL 16000-SDBIH200	90.Z2.82.033.0
FL 16000-SDU200	90.Z2.82.004.0	FL 16000-SDUH200	90.Z2.82.034.0
FL 20000-SDBI200	90.Z2.84.005.0	FL 20000-SDBIH200	90.Z2.84.035.0
FL 20000-SDUI200	90.Z2.84.006.0	FL 20000-SDUIH200	90.Z2.84.036.0
FL 24000-SDBI200	90.Z2.H7.007.0	FL 24000-SDBIH200	90.Z2.H7.037.0
FL 24000-SDUI200	90.Z2.H7.008.0	FL 24000-SDUIH200	90.Z2.H7.038.0
FL 28000-SDBI200	90.Z2.R9.009.0	FL 28000-SDBIH200	90.Z2.R9.039.0
FL 28000-SDUI200	90.Z2.R9.010.0	FL 28000-SDUIH200	90.Z2.R9.040.0
FL 12000-SDBI300	90.Z2.80.021.0	FL 12000-SDBIH300	90.Z2.80.051.0
FL 12000-SDUI300	90.Z2.80.022.0	FL 12000-SDUIH300	90.Z2.80.052.0
FL 16000-SDBI300	90.Z2.82.023.0	FL 16000-SDBIH300	90.Z2.82.053.0
FL 16000-SDUI300	90.Z2.82.024.0	FL 16000-SDUIH300	90.Z2.82.054.0
FL 20000-SDBI300	90.Z2.84.025.0	FL 20000-SDBIH300	90.Z2.84.055.0
FL 20000-SDUI300	90.Z2.84.026.0	FL 20000-SDUIH300	90.Z2.84.056.0
FL 24000-SDBI300	90.Z2.H7.027.0	FL 24000-SDBIH300	90.Z2.H7.057.0
FL 24000-SDUI300	90.Z2.H7.028.0	FL 24000-SDUIH300	90.Z2.H7.058.0
FL 28000-SDBI300	90.Z2.R9.029.0	FL 28000-SDBIH300	90.Z2.R9.059.0
FL 28000-SDUI300	90.Z2.R9.030.0	FL 28000-SDUIH300	90.Z2.R9.060.0

Note: ¹⁾ This is an exhaustive list, to date some references may not yet exist, please contact your local LEM's sales support.

Dimensions FL-SDxl series (in mm)

FL xxxxx-SDxl-200

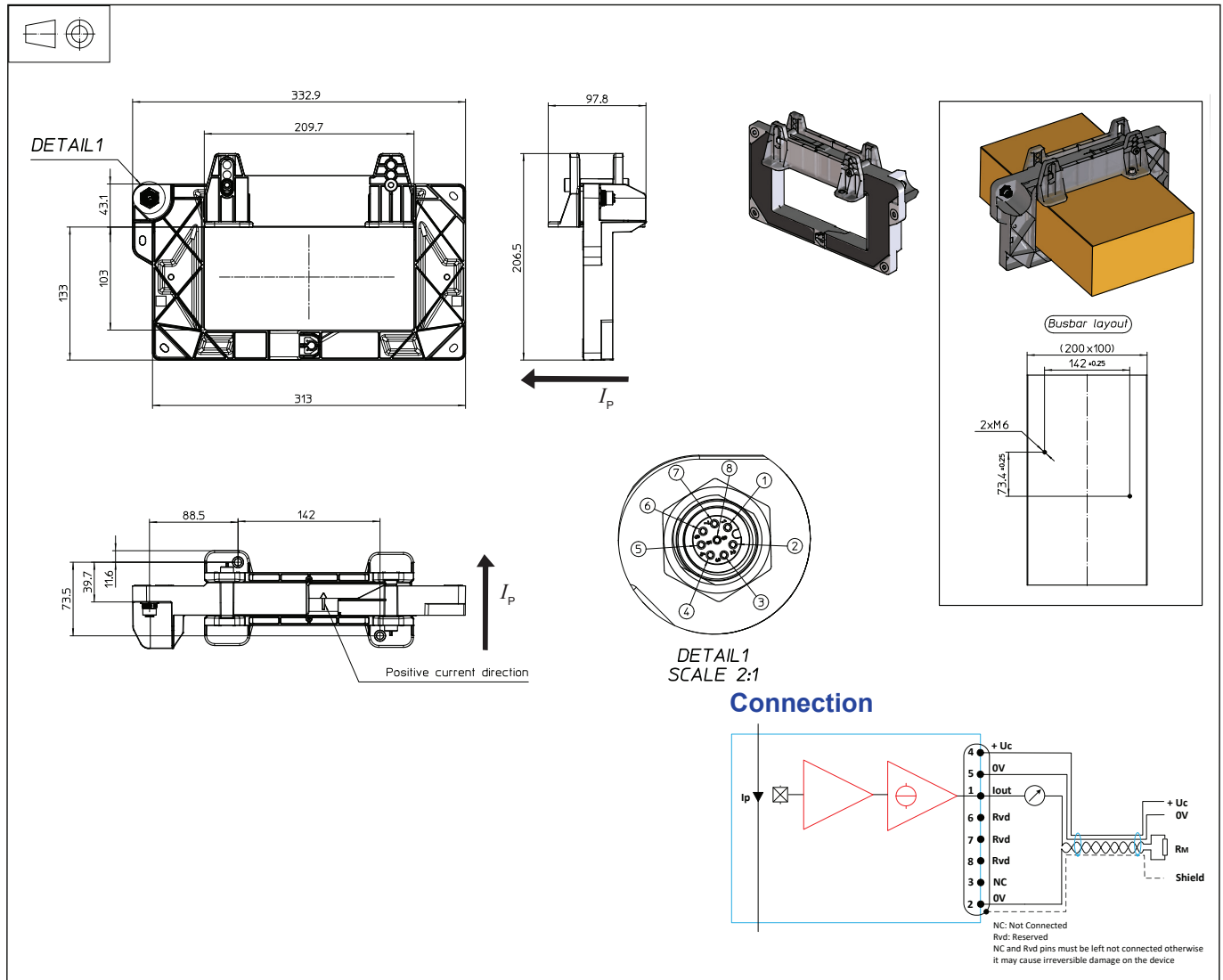

Mechanical characteristics

- General tolerance ± 1 mm
- Maximum primary conductor dimensions:
 200 mm \times 100 mm
 300 mm \times 100 mm
- Transducer fastening
- Bracket fastening $2 \times M6$ (supplied)
- Busbar fastening $2 \times M6$ (not supplied)
- Recommended fastening torque 6 N·m
- Connection to secondary
 Use M12 Male/Male, coding A, 8 terminals, shielded

Remarks

- I_{out} is positive when positive I_p flows in direction of the arrow shown on the drawing above.
- Temperature of the primary conductor should not exceed 105 °C.
- Installation of the transducer must be done unless otherwise specified on the datasheet, according to LEM Transducer Generic Mounting Rules. Please refer to LEM document N°ANE120504 available on our Web site:
<https://www.lem.com/en/file/3137/download>

Dimensions FL-SDxlx series (in mm)

FL xxxxx-SDxl-300

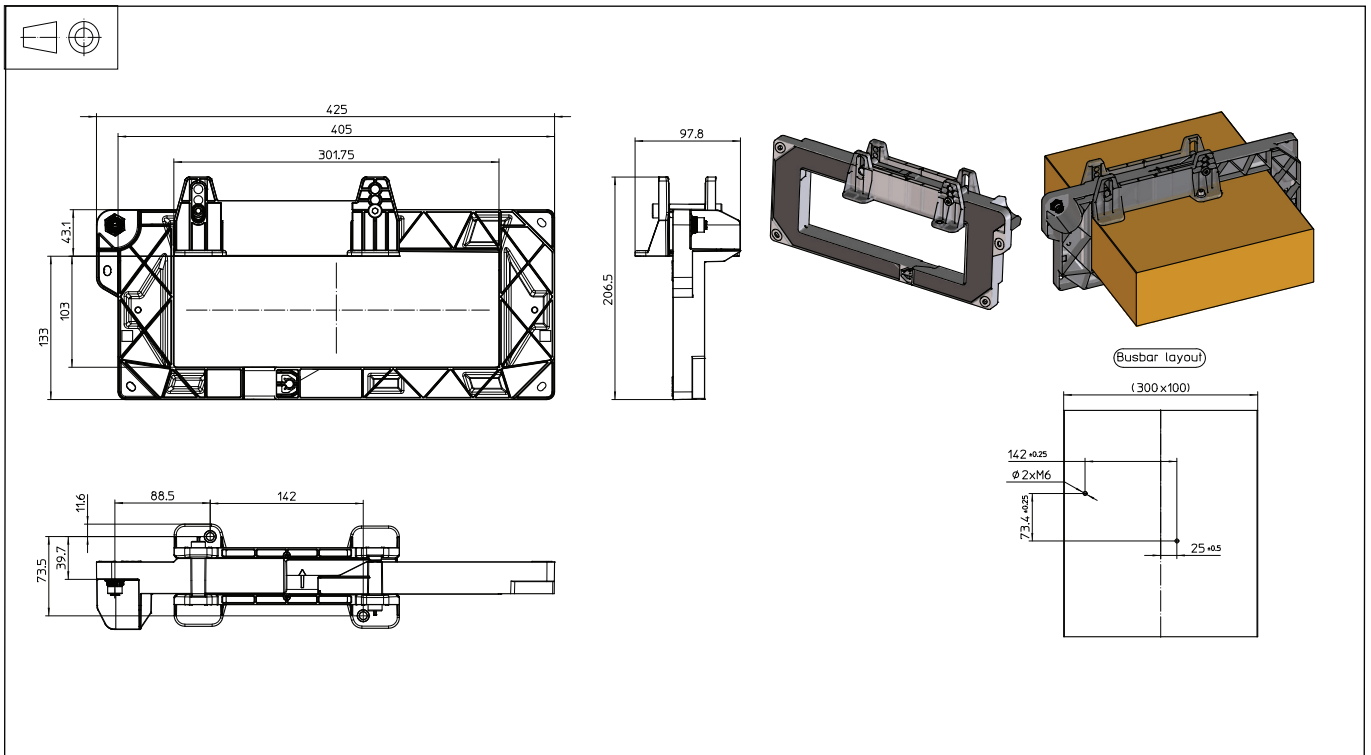

Mechanical characteristics

- General tolerance ± 1 mm
- Maximum primary conductor dimensions:
 200 mm \times 100 mm
 300 mm \times 100 mm
- Transducer fastening
 Bracket fastening 2 \times M6 (supplied)
 Busbar fastening 2 \times M6 (not supplied)
 Recommended fastening torque 6 N·m
- Connection to secondary
 Use M12 Male/Male, coding A, 8 terminals, shielded

Remarks

- I_{out} is positive when positive I_p flows in direction of the arrow shown on the drawing above.
- Temperature of the primary conductor should not exceed 105 °C.
- Installation of the transducer must be done unless otherwise specified on the datasheet, according to LEM Transducer Generic Mounting Rules. Please refer to LEM document N°ANE120504 available on our Web site:
<https://www.lem.com/en/file/3137/download>