

Enclosed Switching Power Supply



Description

Enclosed Switching Power Supply for AC/DC and DC/DC power requirement. The new SPPE family provides flexible OEM power solutions for industrial control and automation applications. This series is available with range from 25 W to 350 W, and from 12 V to 24 V. All the range carries full certification offering a wide range of universal input and screw terminal connections.

All specifications are at nominal values, full load, 25°C unless otherwise stated.

Benefits

- **Universal AC, DC input range.** SPPE Series can be powered with AC Voltage (80-85-90 VAC to 264-305 VAC) or with DC Voltage (100-240 VDC to 370-430 VDC).
- **Reliable power in very compact dimensions.** SPPE offers high compactness, miniature size, long life and high power density, efficiency and reliability.
- **Reliable critical protection.** The operation safety is guaranteed by the various output protections: Over Voltage (OVC), Over Load (OLP), Short Circuit (SCP), Over Power (OVP) and Over Temperature (OTP) depending on the model.
- **Built-in features.** All SPPE models come with the DC OK LED.
- **Wide operating and isolation ranges.** The operating temperature range is from -30/-40°C to +70/+85°C, depending on the model.
- **High altitude.** SPPE series assures the operating altitude up to 5000m and high I/O isolation voltage up to 4000 VAC, with OVC III.

Applications

This product is suitable for all applications which require single-phase power supply with universal AC or DC voltage input range, high efficiency and high compactness for panel mounting solution. Installations with limited panel space, industrial equipment, machinery.

Main functions

- High efficiency up to 91.5%
- Universal AC, DC input voltage range
- 25 W, 35 W, 50 W, 75 W, 150 W, 200 W, 350 W

References

Order code



SPPE 1



Enter the code entering the corresponding option instead of .

| Code | Option | Description | Notes |
|--------------------------|--------|--------------------|----------------------|
| S | - | Switching | Device typology |
| P | - | Power supply | |
| P | - | Panel mount | |
| E | - | High efficiency | Mounting |
| <input type="checkbox"/> | 12 | 12 VDC | Rated output voltage |
| | 24 | 24 VDC | |
| <input type="checkbox"/> | 25 | 25 W | Rated output power |
| | 35 | 35 W | |
| | 50 | 50 W | |
| | 75 | 75 W | |
| | 150 | 150 W | |
| | 200 | 200 W | |
| 1 | 350 | 350 W | Input type |
| | - | Single phase input | |

Selection guide

| Output Voltage | Output power | | | | | | |
|----------------|--------------|-----------|-----------|-----------|------------|------------|------------|
| | 25 W | 35 W | 50 W | 75 W | 150 W | 200 W | 350 W |
| 12 VDC | SPPE12251 | SPPE12351 | SPPE12501 | SPPE12751 | SPPE121501 | SPPE122001 | SPPE123501 |
| 24 VDC | SPPE24251 | SPPE24351 | SPPE24501 | SPPE24751 | SPPE241501 | SPPE242001 | SPPE243501 |

Further reading

| Information | Where to find it | QR |
|-------------------------|---|---|
| SPPE Data sheet | https://gavazziautomation.com/images/PIM/DATASHEET/ENG/SPPE_DS_EN.pdf |  |
| SPPE Instruction manual | https://gavazziautomation.com/images/PIM/MANUALS/ENG/SPPE_IM.pdf |  |

Structure

SPPE 25 W

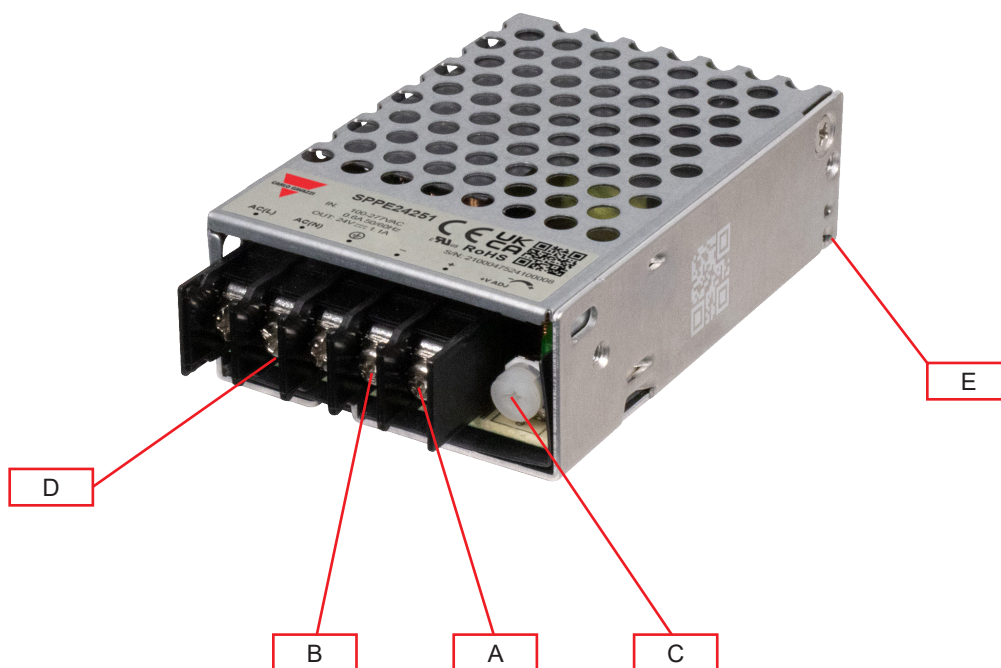

| Element | Component | Function |
|---------|-------------------------------|--------------------------------------|
| A | + V terminals | Positive DC output terminals |
| B | - V terminals | Negative DC output terminals |
| C | VADJ Trimmer | Output voltage adjustment |
| D | Power supply terminals | L, N supply terminals + GND |
| E | Panel Mounting Predisposition | Predispositions present on two sides |

SPPE 35 / 50 W

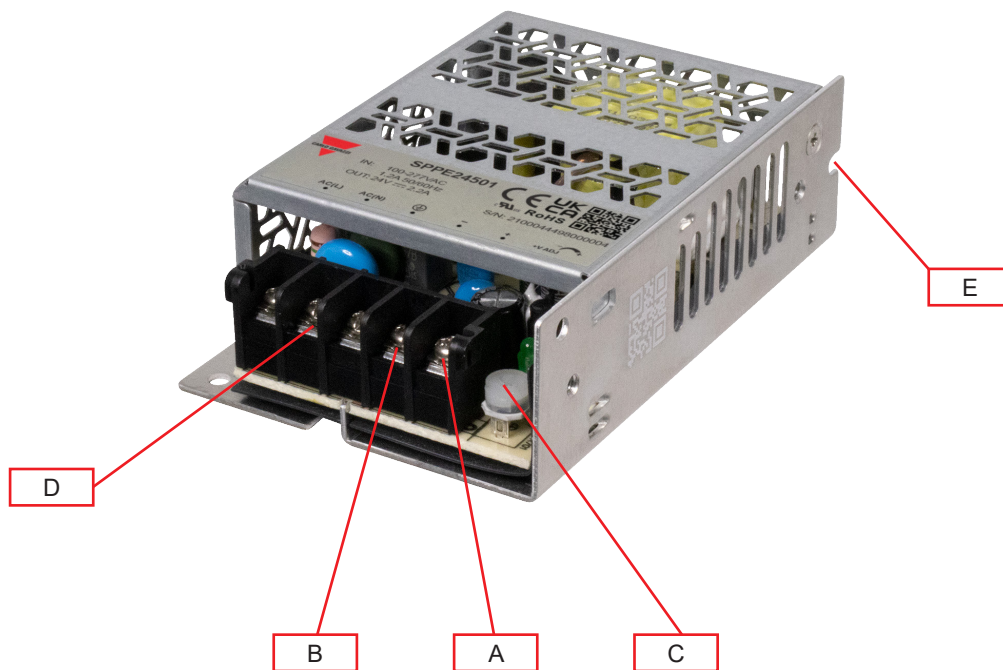

| Element | Component | Function |
|---------|-------------------------------|--------------------------------------|
| A | + V terminals | Positive DC output terminals |
| B | - V terminals | Negative DC output terminals |
| C | VADJ Trimmer | Output voltage adjustment |
| D | Power supply terminals | L, N supply terminals + GND |
| E | Panel Mounting Predisposition | Predispositions present on two sides |

SPPE 75 W

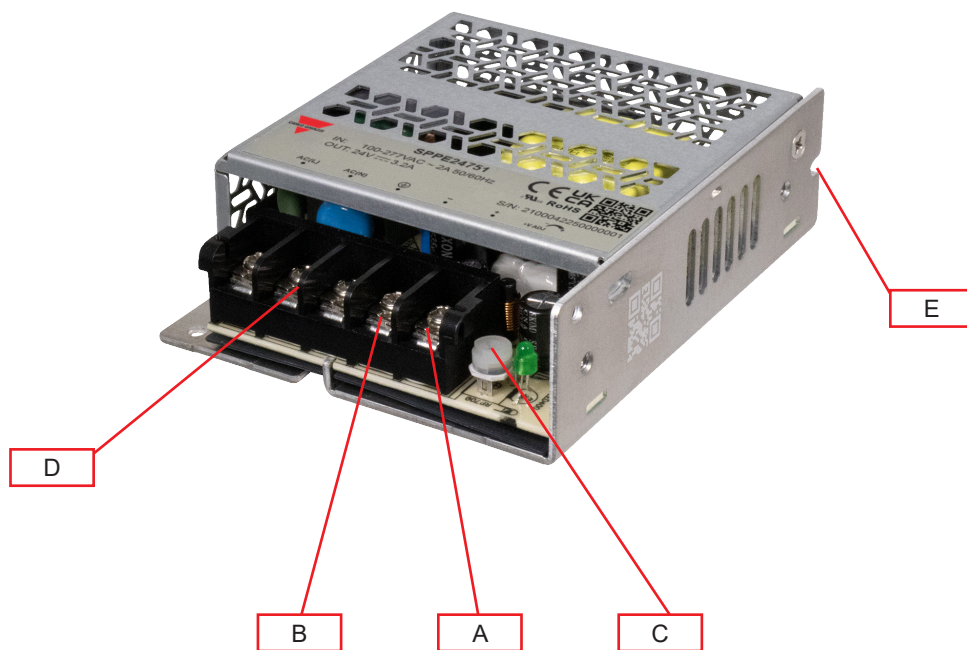

| Element | Component | Function |
|---------|-------------------------------|--------------------------------------|
| A | + V terminals | Positive DC output terminals |
| B | - V terminals | Negative DC output terminals |
| C | VADJ Trimmer | Output voltage adjustment |
| D | Power supply terminals | L, N supply terminals + GND |
| E | Panel Mounting Predisposition | Predispositions present on two sides |

SPPE 150 W

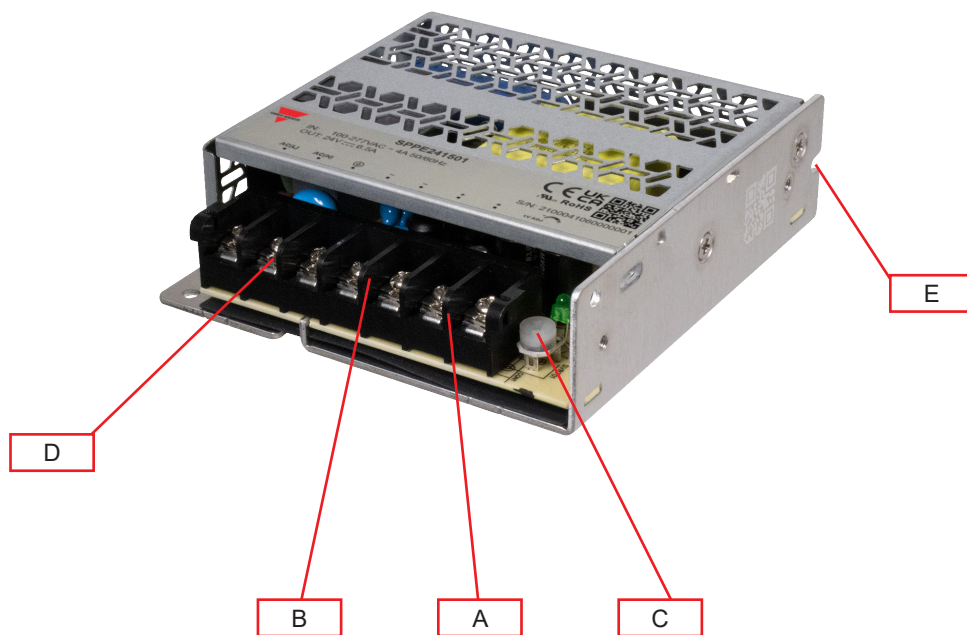

| Element | Component | Function |
|----------|-------------------------------|--------------------------------------|
| A | + V terminals | Positive DC output terminals |
| B | - V terminals | Negative DC output terminals |
| C | VADJ Trimmer | Output voltage adjustment |
| D | Power supply terminals | L, N supply terminals + GND |
| E | Panel Mounting Predisposition | Predispositions present on two sides |

SPPE 200 W

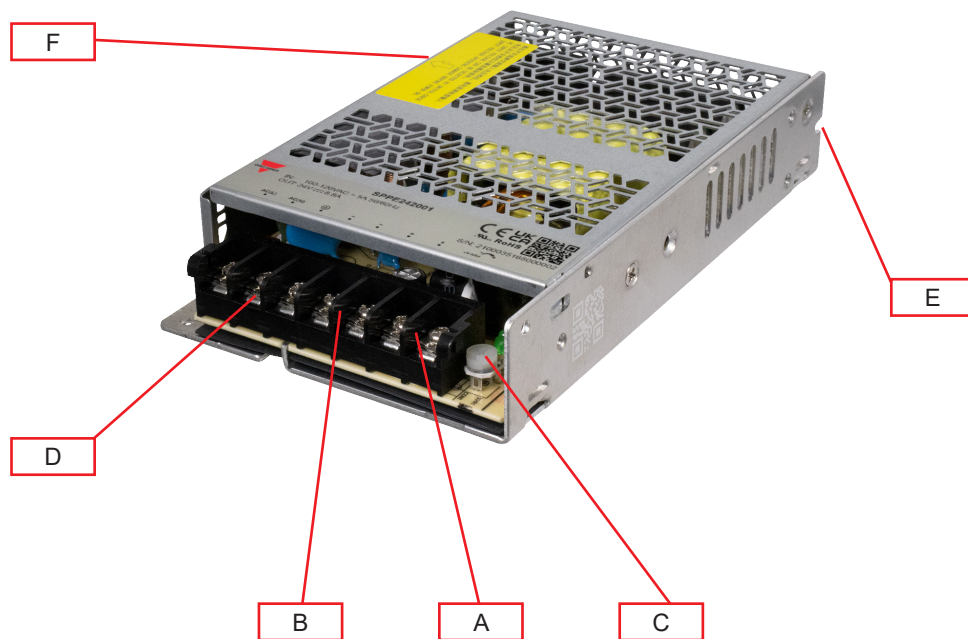

| Element | Component | Function |
|---------|-------------------------------|--------------------------------------|
| A | + V terminals | Positive DC output terminals |
| B | - V terminals | Negative DC output terminals |
| C | VADJ Trimmer | Output voltage adjustment |
| D | Power supply terminals | L, N supply terminals + GND |
| E | Panel Mounting Predisposition | Predispositions present on two sides |
| F | Switch | AC/DC input voltage switch |

SPPE 350 W

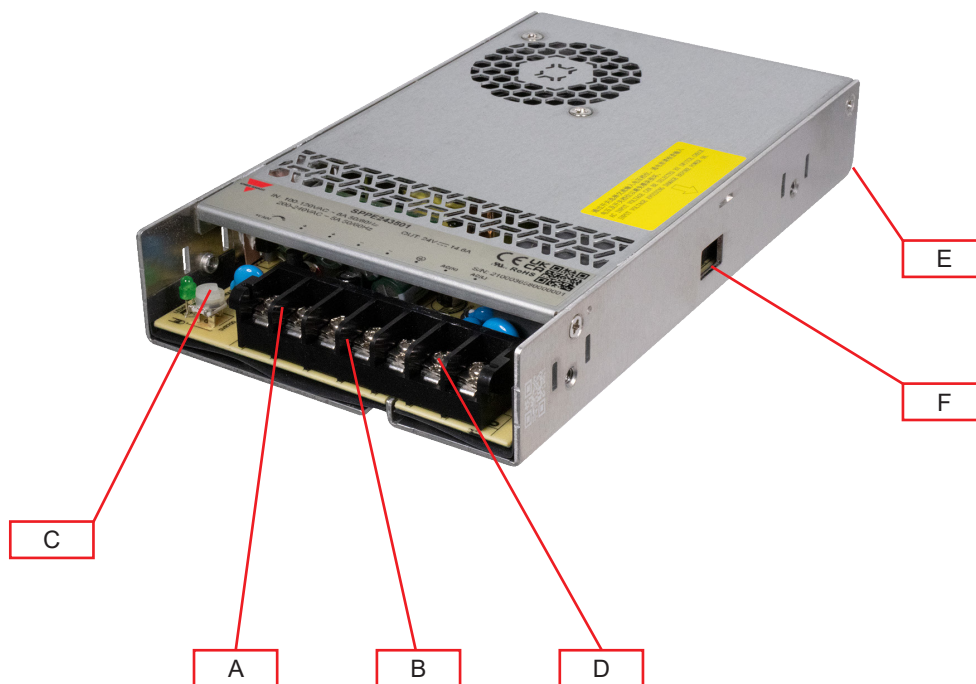

| Element | Component | Function |
|---------|------------------------------|--------------------------------------|
| A | + V terminals | Positive DC output terminals |
| B | - V terminals | Negative DC output terminals |
| C | VADJ Trimmer | Output voltage adjustment |
| D | Power supply terminals | L, N supply terminals + GND |
| E | Wall Mounting Predisposition | Predispositions present on two sides |
| F | Switch | AC/DC input voltage switch |

Features

General data

| | | 25 W | 35 W | 50 W | 75 W |
|------------------------------|--------|-----------------------|------------------------|-----------------|----------|
| Leakage current | | < 0.5 mA (277 VAC) | < 0.75 mA (277 VAC) | | |
| Efficiency @230 VAC | 12 VDC | 85 % | 87.5 % | 88 % | 89 % |
| | 24 VDC | 86 % | 88.5 % | 89.5 % | 91 % |
| Power loss @ nominal load | 12 VDC | 4.45 W | 5.14 W | 6.95 W | 8.90 W |
| | 24 VDC | 4.15 W | 4.68 W | 6.19 W | 7.60 W |
| Switching frequency | | 65 kHz | 95 kHz | 90 kHz | <150 kHz |
| Ingress protection | | IP20 | | | |
| MTBF (MIL-HDBK-217F) | | >450,000 h | >300,000 h | | |
| Case material | | Metal | | | |
| Weight | | 115 g (0.25 lb) | 150 g (0.33 lb) | 220 g (0.49 lb) | |
| Mounting | | Panel mounting | | | |

| | | 150 W | 200 W | 350 W |
|------------------------------|--------|-----------------------|------------------------|--------------------------------------|
| Leakage current | | < 0.5 mA (277 VAC) | < 0.75 mA (240 VAC) | < 0.5 mA (touch) < 2.0 mA (earth) |
| Efficiency @230 VAC | 12 VDC | 91.5 % | 89 % | 85.5 % |
| | 24 VDC | | 91 % | 88 % |
| Power loss @ nominal load | 12 VDC | 13.93 W | 25.21 W | 59.02 W |
| | 24 VDC | 14.49 W | 20.89 W | 47.78 W |
| Switching frequency | | 90 kHz | - | 65 kHz |
| Ingress protection | | IP20 | | |
| MTBF (MIL-HDBK-217F) | | >300,000 h | | |
| Case material | | Metal | | |
| Weight | | 270 g (0.60 lb) | 415 g (0.92 lb) | 570 g (1.26 lb) |
| Mounting | | Panel mounting | | |

SPPE 75 W
Unit: mm [inch]

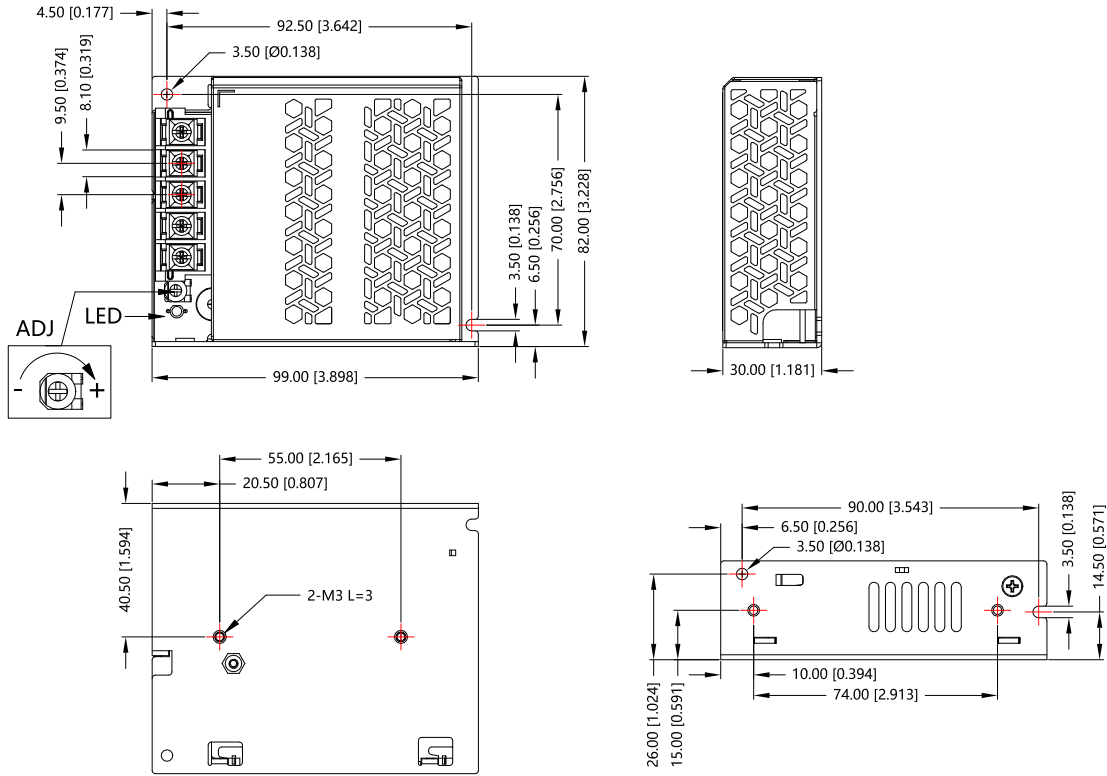

SPPE 150 W
Unit: mm [inch]

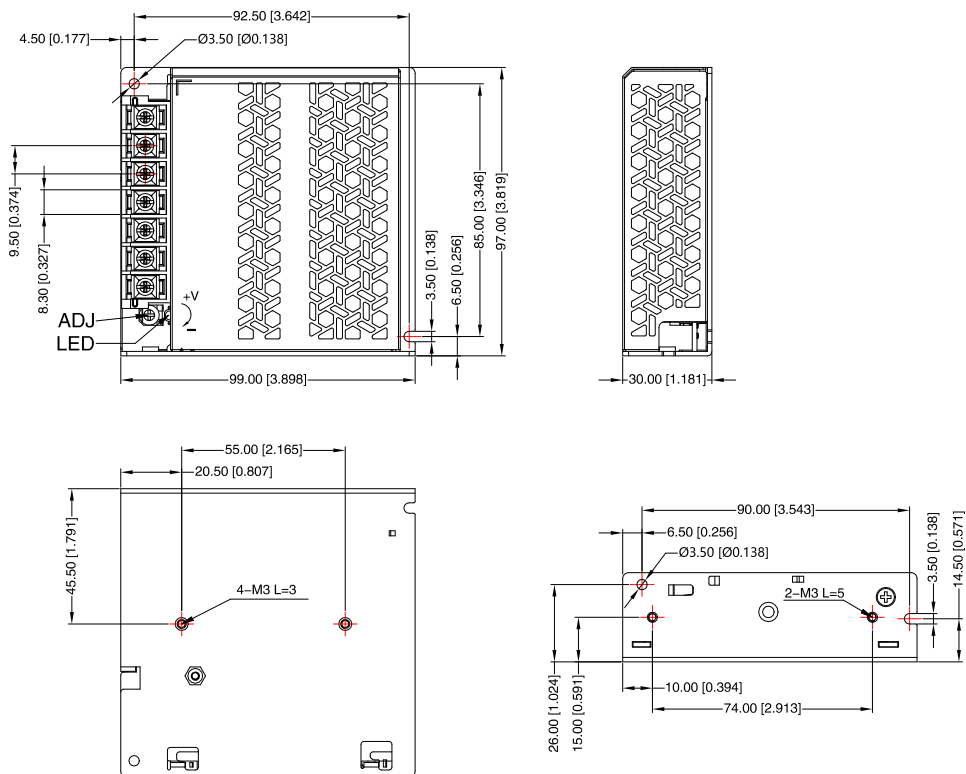

SPPE 200 W
Unit: mm [inch]

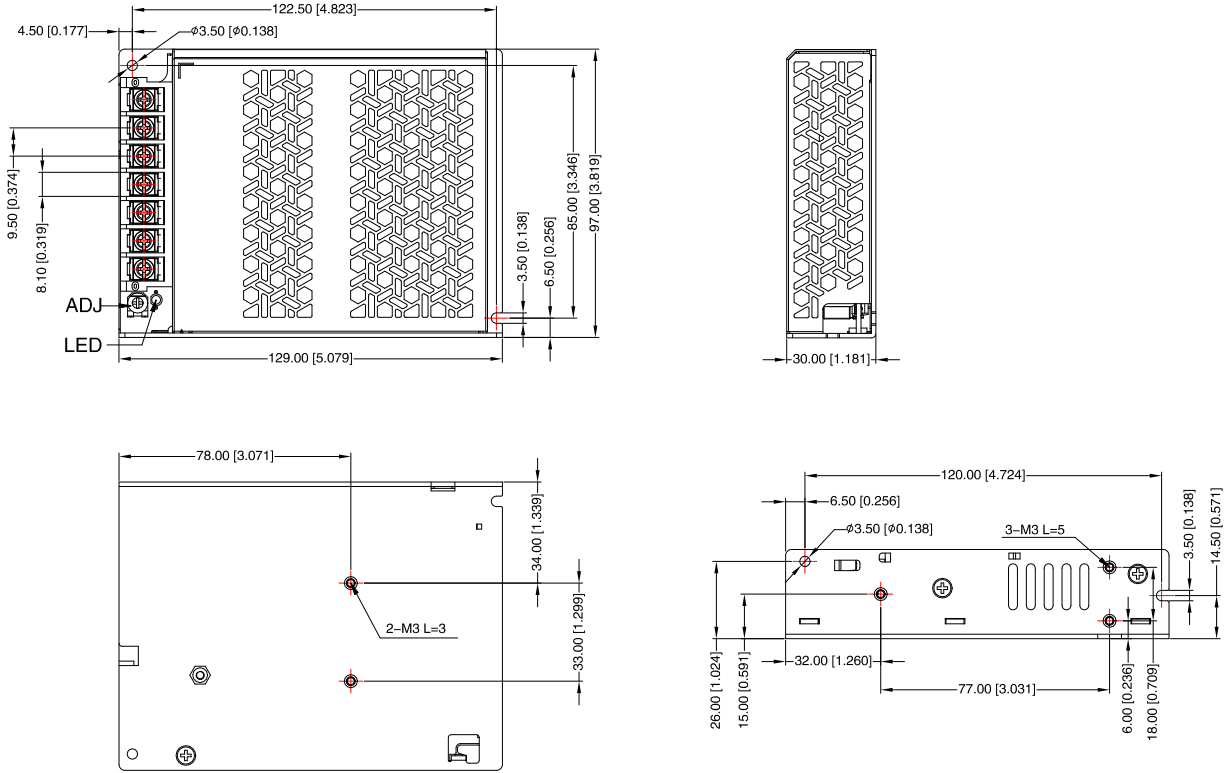

SPPE 350 W
Unit: mm [inch]

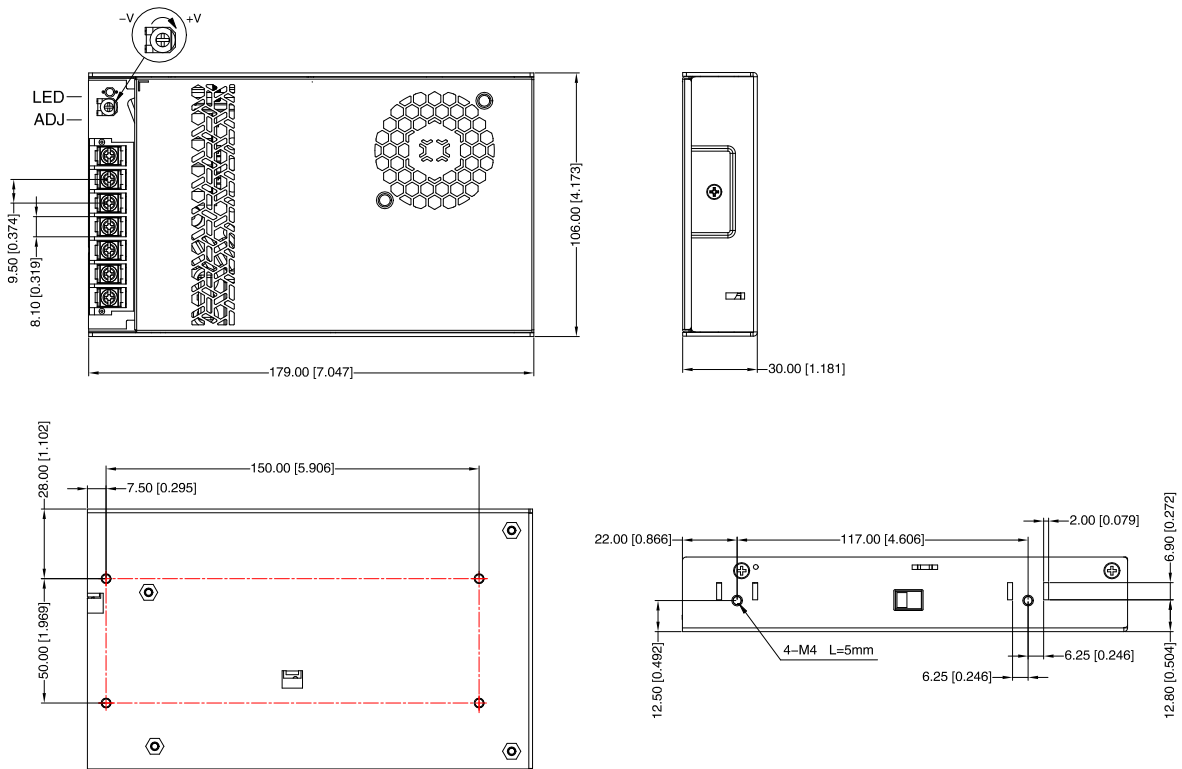

Connection diagram

Terminal markings

SPPE 25 W

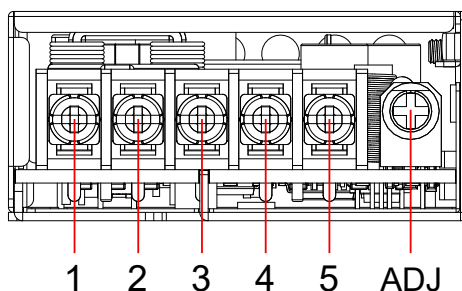

| Terminal | Designation | Description |
|----------|-----------------|--|
| 1 | AC(L) | Input terminals (phase conductor, no polarity with DC input) |
| 2 | AC(N) | Input terminals (neutral conductor, no polarity with DC input) |
| 3 | PE | Ground this terminal to minimize high frequency emissions |
| 4 | -V _o | Negative output terminal |
| 5 | +V _o | Positive output terminal |
| | Vout ADJ | Potentiometer for output voltage adjustment |

SPPE 35 / 50 / 75 W

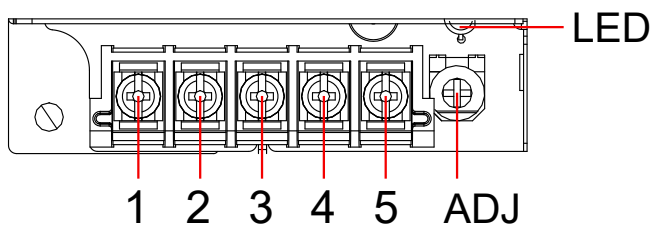

| Terminal | Designation | Description |
|----------|-----------------|--|
| 1 | AC(L) | Input terminals (phase conductor, no polarity with DC input) |
| 2 | AC(N) | Input terminals (neutral conductor, no polarity with DC input) |
| 3 | PE | Ground this terminal to minimize high frequency emissions |
| 4 | -V _o | Negative output terminal |
| 5 | +V _o | Positive output terminal |
| | Vout ADJ | Potentiometer for output voltage adjustment |

SPPE 150 / 200 W

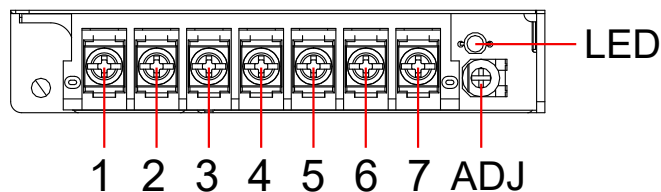

| Terminal | Designation | Description |
|----------|-----------------|--|
| 1 | AC(L) | Input terminals (phase conductor, no polarity with DC input) |
| 2 | AC(N) | Input terminals (neutral conductor, no polarity with DC input) |
| 3 | PE | Ground this terminal to minimize high frequency emissions |
| 4, 5 | -V _o | Negative output terminal |
| 6, 7 | +V _o | Positive output terminal |
| | Vout ADJ | Potentiometer for output voltage adjustment |
| | DC Status | LED indication of power supply output status |

SPPE 350 W

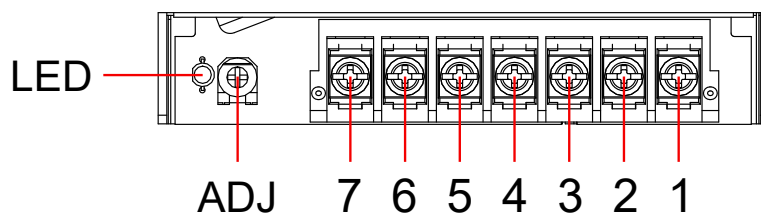

| Terminal | Designation | Description |
|----------|-----------------|--|
| 1 | AC(L) | Input terminals (phase conductor, no polarity with DC input) |
| 2 | AC(N) | Input terminals (neutral conductor, no polarity with DC input) |
| 3 | PE | Ground this terminal to minimize high frequency emissions |
| 4, 5 | -V _o | Negative output terminal |
| 6, 7 | +V _o | Positive output terminal |
| | Vout ADJ | Potentiometer for output voltage adjustment |
| | DC Status | LED indication of power supply output status |



Environmental

| | 25 W | 35 W | 50 W | 75 W |
|--------------------------------|-----------------------------------|-----------------------------------|------|------|
| Operating temperature | -30°C to 70°C (-22°F to 158°F) | -40°C to 85°C (-40°F to 185°F) | | |
| Storage temperature | -40°C to 85°C (-40°F to 185°F) | | | |
| Operating humidity | 20 - 90 % RH non-condensing | | | |
| Storage humidity | < 95 % RH non-condensing | | | |
| Operating altitude | 5000 m | | | |
| Temperature derating | Refer to derating diagram | | | |
| Ventilation and cooling | Cooling by free air convection | | | |

| | 150 W | 200 W | 350 W |
|--------------------------------|-----------------------------------|-----------------------------|--------------------|
| Operating temperature | -40°C to 85°C (-40°F to 185°F) | | |
| Storage temperature | | | |
| Operating humidity | < 95 % RH non-condensing | 20 - 90 % RH non-condensing | |
| Storage humidity | | 10 - 95 % RH non-condensing | |
| Operating altitude | 5000 m | | |
| Temperature derating | Refer to derating diagram | | |
| Ventilation and cooling | Cooling by free air convection | | Forced air cooling |



Compatibility and conformity

| | 25 W | 35 W | 50 W | 75 W |
|--|--|---|---|---|
| Safety standards | EN61558-1 EN61558-2-2 EN61558-2-16 EN61204-7 UL/EN62368-1 IS13252 (Part1) safety approved EN60335 OVCII | EN61558-1 EN61558-2-2 EN61558-2-16 EN61204-7 UL/EN62368-1 EN62477-1 EN60335 OVCII | EN61558-1 EN61558-2-2 EN61558-2-16 EN61204-7 UL/EN62368-1 EN62477-1 EN60335 OVCII | EN61558-1 EN61558-2-2 EN61558-2-16 EN61204-7 UL/EN62368-1 EN62477 EN60335 OVCII |
| Approvals | | | | |
| Conducted (CS) IEC/EN 61000-4-6 | 10 Vrms (PC A) | | | |
| Voltage dips IEC/EN61000-4-11 | 0% (PC B) | | | |
| Voltage interruptions IEC/EN61000-4-11 | 70% (PC B) | | | |
| EMC emission CE: CISPR32/EN55032 RE: CISPR32/EN55032 | Class B Class B | | | |
| Harmonic current IEC/EN61000-3-2 | - | | | Class A |
| EMC immunity ESD: IEC/EN 61000-4-2 RS: IEC/EN 61000-4-3 EFT: IEC/EN 61000-4-4 Surge: IEC/EN 61000-4-5 | contact ± 6 kV / air ± 8 kV 10 V/m ± 2 kV line to line ±1 kV line to ground ±2 kV | contact ± 6 kV / air ± 8 kV 10 V/m ± 4 kV line to line ±2 kV line to ground ±4 kV | | |

Compatibility and conformity (continued)

| | 150 W | 200 W | 350 W |
|--|--|--|--|
| Safety standards | EN61558-1, EN61558-2-2, EN61558-2-16, EN61204-7, UL/EN62368-1, EN62477 | EN61558-1, EN61558-2-2, EN61558-2-16, EN61204-7, UL/EN62368-1, EN62477-1 | |
| Approvals |  | | |
| Conducted (CS) IEC/EN 61000-4-6 | 10 Vrms (PC A) | | |
| Voltage dips IEC/EN61000-4-11 | 30% for 25 cycles 100% for 1 cycle (PC B) | 0% (PC B) 70% (PC B) | 0% (PC B) 70% (PC B) |
| Voltage interruptions IEC/EN61000-4-11 | 100% for 250 cycles (PC B) | | 0% of 230 VAC (PC A) 0% for 5000 ms (PC B) |
| EMC emission CE: CISPR32/EN55032 RE: CISPR32/EN55032 | Class B Class B | Class A Class A | |
| Harmonic current IEC/EN61000-3-2 | - | | |
| EMC immunity ESD: IEC/EN 61000-4-2 RS: IEC/EN 61000-4-3 EFT: IEC/EN 61000-4-4 Surge: IEC/EN 61000-4-5 PFMF: IEC/EN 61000-4-8 | contact ± 6 kV / air ± 8 kV 10 V/m ± 4 kV line to line ±2 kV line to ground ±4 kV 30 A/m | contact ± 6 kV / air ± 8 kV 10 V/m ± 2 kV line to line ±2 kV line to ground ±4 kV 30 A/m | contact ± 6 kV / air ± 8 kV 10 V/m ± 4 kV line to line ±2 kV line to ground ±4 kV 30 A/m |



Insulation

| | 25 W | 35 W | 50 W | 75 W |
|---|---------------------|--------------------|------|------|
| Insulation / withstand voltage (input / GND) | 2.0 kVAC / < 10 mA | 2.0 kVAC / < 5 mA | | |
| Insulation / withstand voltage (input / output) | 4.0 kVAC / < 10 mA | 4.0 kVAC / < 5 mA | | |
| Insulation / withstand voltage (output / GND) | 1.25 kVAC / < 10 mA | 1.25 kVAC / < 5 mA | | |
| Insulation resistance | ≥ 100 MΩ | | | |
| Overvoltage category | III | | | |
| Pollution degree | 2 | | | |

| | 150 W | 200 W | 350 W |
|---|--------------------|-------------------|-------------------|
| Insulation / withstand voltage (input / GND) | 4.0 kVAC / < 5 mA | 2.0 kVAC / < 5 mA | 4.0 kVAC / < 5 mA |
| Insulation / withstand voltage (input / output) | 2.0 kVAC / < 5 mA | 4.0 kVAC / < 5 mA | 2.0 kVAC / < 3 mA |
| Insulation / withstand voltage (output / GND) | 1.25 kVAC / < 5 mA | 0.5 kVAC / < 5 mA | 0.5 kVAC / < 3 mA |
| Insulation resistance | ≥ 100 MΩ | | |
| Overvoltage category | III | | |
| Pollution degree | 2 | | |



Inputs

| | 25 W | 35 W | 50 W | 75 W |
|---|--------------------------------------|-------------------------------------|--------------------|----------------|
| Rated input voltage | 100 VAC to 277 VAC | | | |
| Input voltage range | 85 VAC to 305 VAC (305 VAC max.) | 80 VAC to 305 VAC (305 VAC max.) | | |
| | 100 VDC to 430 VDC (430 VDC max.) | | | |
| AC current (max) 115 VAC 230 VAC | < 0.6 A < 0.34 A | < 0.8 A < 0.6 A | < 1.2 A < 0.8 A | < 2 A < 1 A |
| Frequency range | 47 Hz to 63 Hz | | | |
| Inrush current 115 VAC 230 VAC | 20 A 40 A | 30 A 50 A | 30 A 60 A | 40 A 75 A |
| Standby power consumption | < 0.3 W | < 0.5 W | | < 0.3 W |

| | 150 W | 200 W | 350 W |
|---|--------------------------------------|--|----------------|
| Rated input voltage | 100 VAC to 277 VAC | 100 VAC to 120 VAC 200 VAC to 240 VAC | |
| Input voltage range | 80 VAC to 305 VAC (305 VAC max.) | Low voltage - switch in position of 115: 90 VAC to 132 VAC (132 VAC max.) High voltage - switch in position of 230: 180 VAC to 264 VAC (264 VAC max.) | |
| | 100 VDC to 430 VDC (430 VDC max.) | Switch in position of 230: 240 VDC to 370 VDC (370 VDC max.) | |
| AC current (max) 115 VAC 230 VAC | < 4 A < 2 A | < 5 A < 3 A | < 8 A < 4 A |
| Frequency range | 47 Hz to 63 Hz | | |
| Inrush current 115 VAC 230 VAC | 30 A 60 A | < 80 A < 80 A | 60 A 60 A |
| Standby power consumption | < 0.5 W | < 0.75 W | |



▶ Outputs

| | 25 W | 35 W | 50 W | 75 W |
|---|--|--------------------------------------|----------------------------|--------------------------------------|
| Output power 12 VDC 24 VDC | 25.2 W 25.5 W | 36 W 36 W | 51 W 52.8 W | 72 W 76.8 W |
| Voltage accuracy | ±1 % | | | |
| Line regulation | ±0.5 % | | | |
| Load regulation | | | | |
| Minimum load | > 0 % | | | |
| Voltage regulation span 12 VDC 24 VDC | 10.8 V to 13.2 V 22 V to 27.6 V | 11.4 V to 13.8 V 22.8 V to 27.6 V | | 10.2 V to 13.8 V 21.6 V to 28.8 V |
| Rated output current 12 VDC 24 VDC | 2.1 A 1.1 A | 3 A 1.5 A | 4.2 A 2.2 A | 6 A 3.2 A |
| Ripple and noise 20 MHz bandwidth 12 VDC 24 VDC | < 100 mV < 100 mV | 60 - 150 mV 100 - 150 mV | 65 - 150 mV 80 - 150 mV | 120 mV 150 mV |
| Hold up time 115 VAC 230 VAC | 8 ms 60 ms | 6 ms 35 ms | 6 ms 30 ms | ≥ 8 ms ≥ 55 ms |
| Mounting space | No requirement for the installation distance | | | |
| Series operation | Yes | | | |
| Parallel operation | No | | | |
| Power boost | No | | | |

Outputs (continued)

| | 150 W | 200 W | 350 W |
|---|--|-------------------|------------------|
| Output power 12 VDC 24 VDC | 150 W 156 W | 204 W 211.2 W | 348 W 350.4 W |
| Voltage accuracy 12 VDC 24 VDC | ±1 % ±1 % | ±1.5 % ±1 % | |
| Line regulation | ±0.5 % | | |
| Load regulation 12 VDC 24 VDC | ±0.5 % ±0.5 % | ±1 % ±0.5 % | |
| Minimum load | > 0 % | | |
| Voltage regulation span 12 VDC 24 VDC | 11.4 V to 13.8 V 22.8 V to 27.6 V | | |
| Rated output current 12 VDC 24 VDC | 12.5 A 6.5 A | 17 A 8.8 A | 29 A 14.6 A |
| Ripple and noise 20 MHz bandwidth 12 VDC 24 VDC | ≤ 150 mV ≤ 200 mV | 150 mV 150 mV | 180 mV 240 mV |
| Hold up time 115 VAC 230 VAC | 8 ms 40 ms | ≥ 8 ms ≥ 16 ms | 12 ms 16 ms- |
| Mounting space | No requirement for the installation distance | | |
| Series operation | Yes | | |
| Parallel operation | No | | |
| Power boost | No | | |

Performance

Current derating

25 W

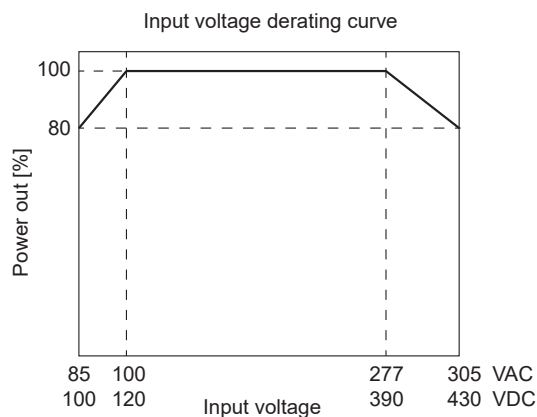
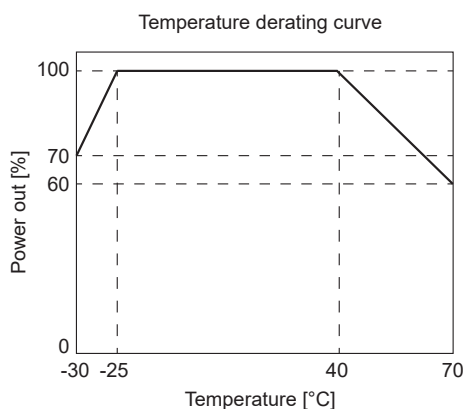

35 W

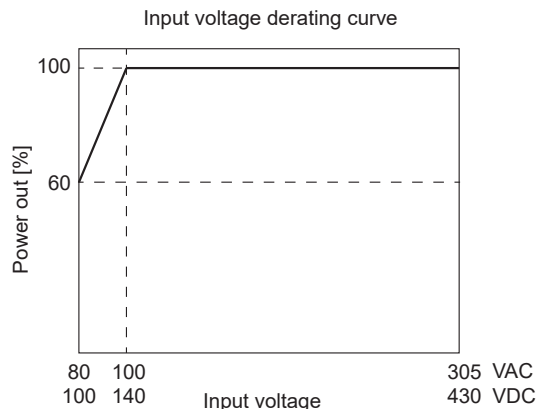
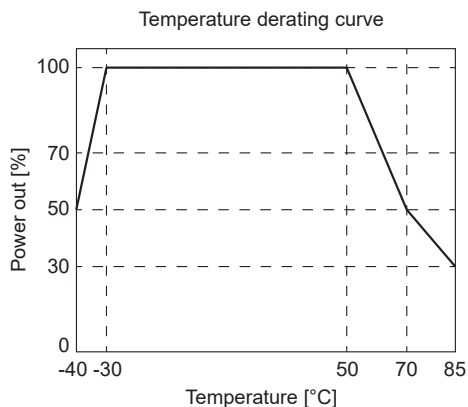

50 W

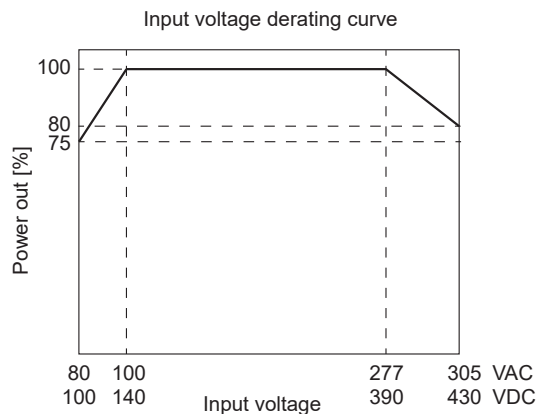
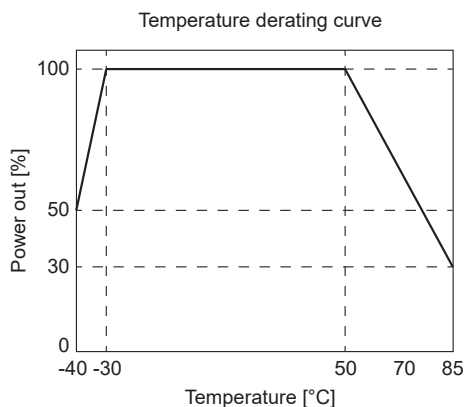

Current derating (continued)

75 W

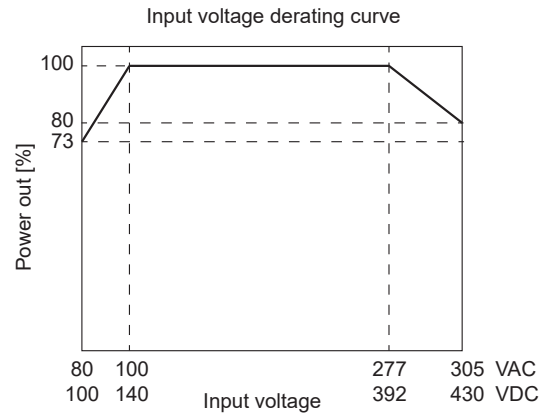
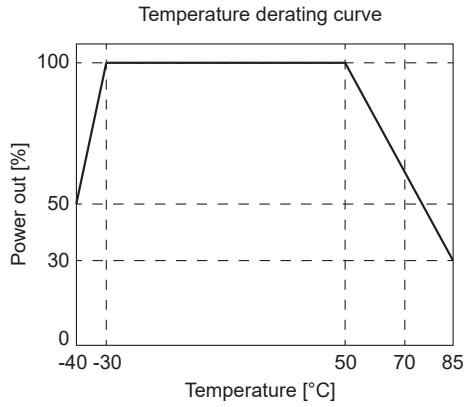

150 W

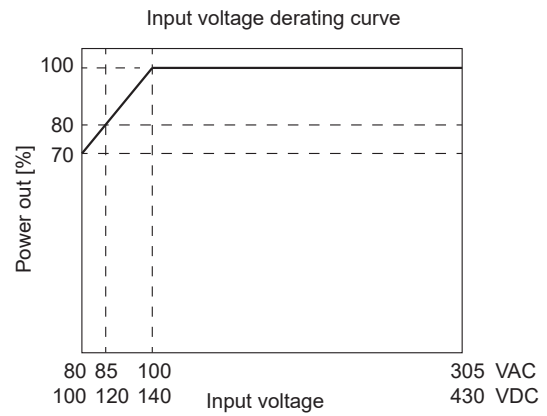
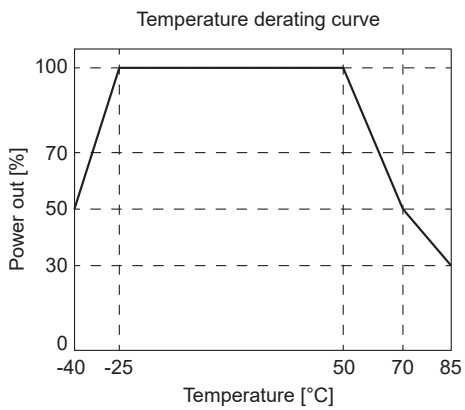

200 W

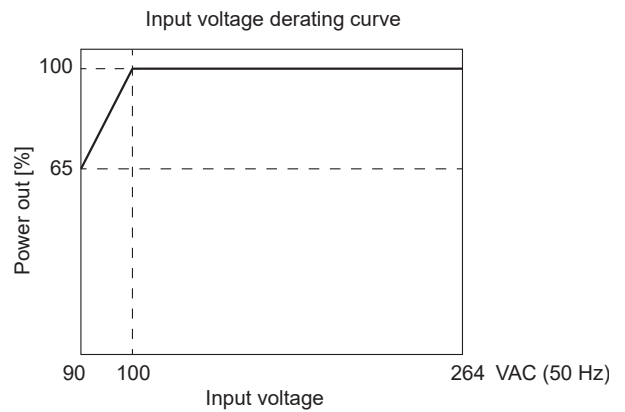
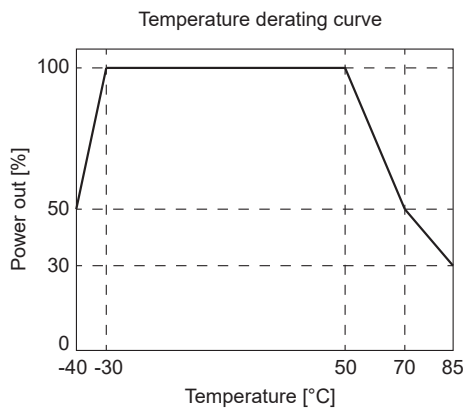

Current derating (continued)

350 W

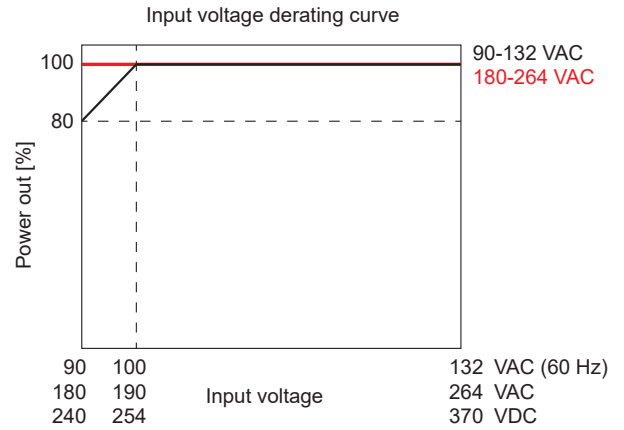
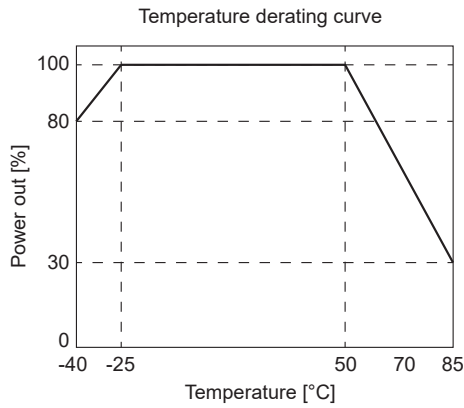

Efficiency

25 W

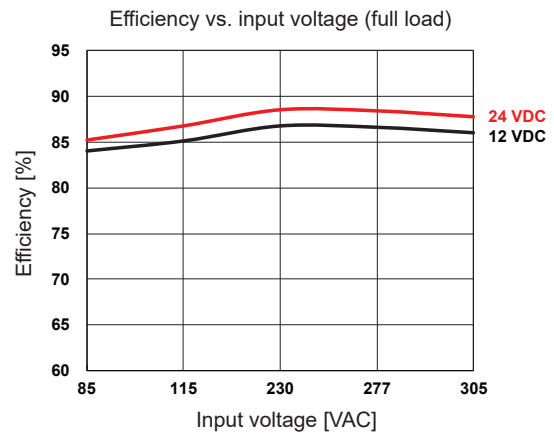
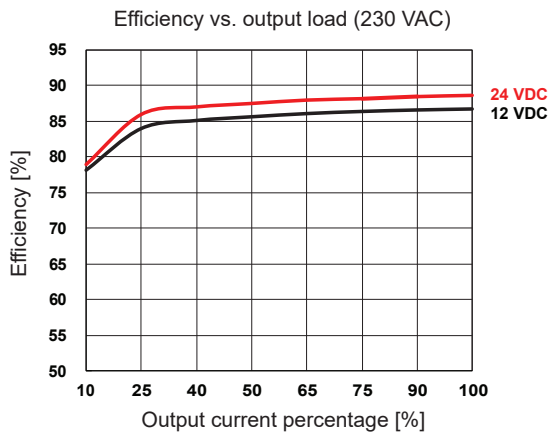

35 W

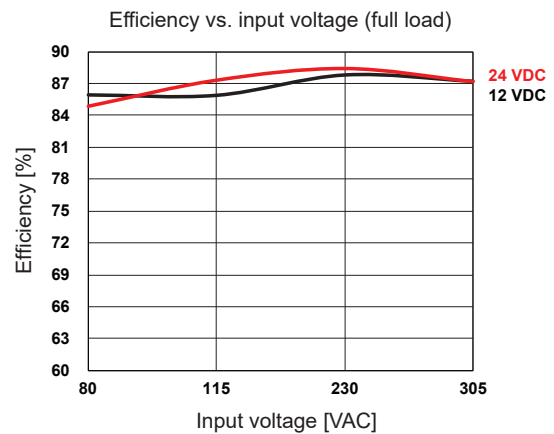
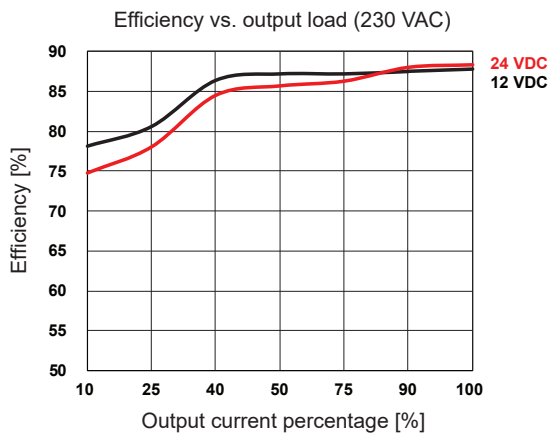

Efficiency (continued)

50 W

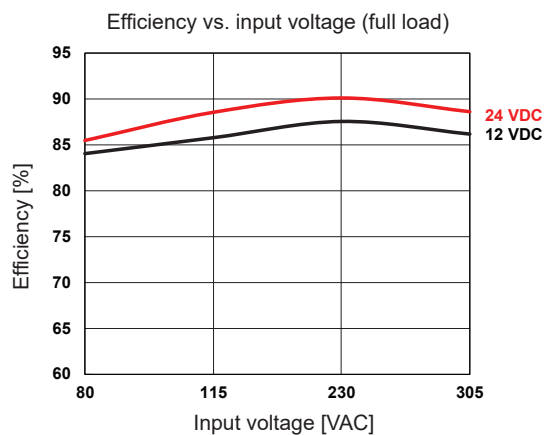
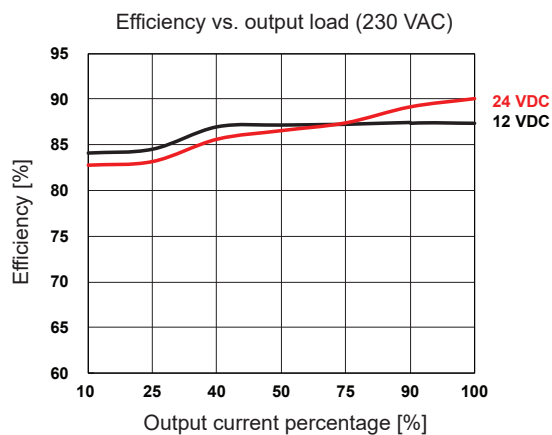

75 W

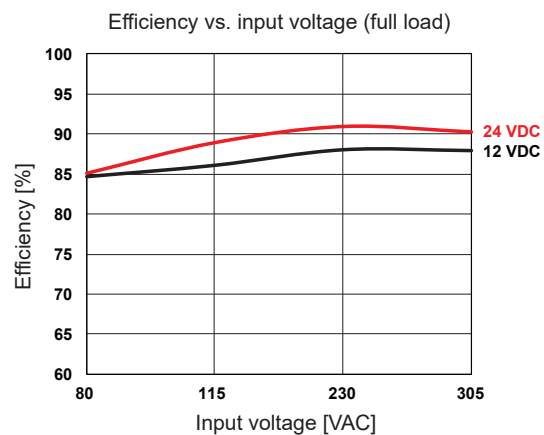
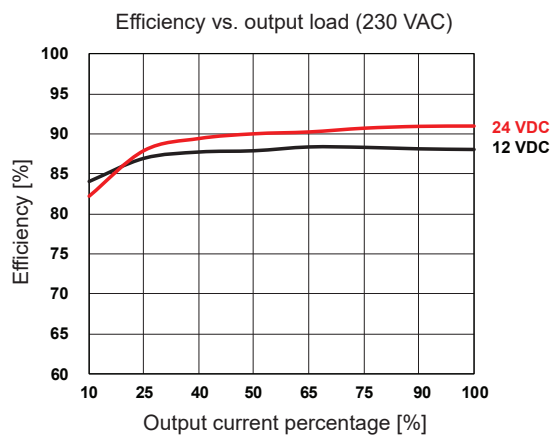

150 W

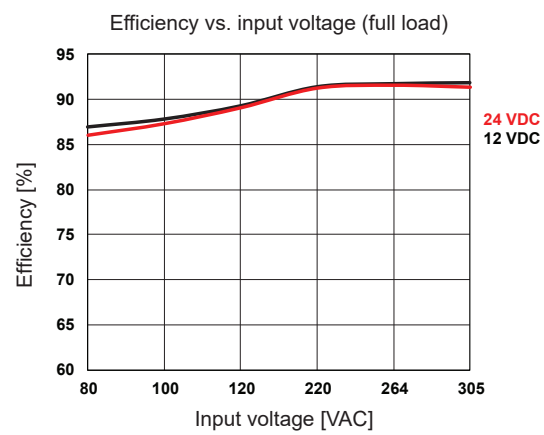
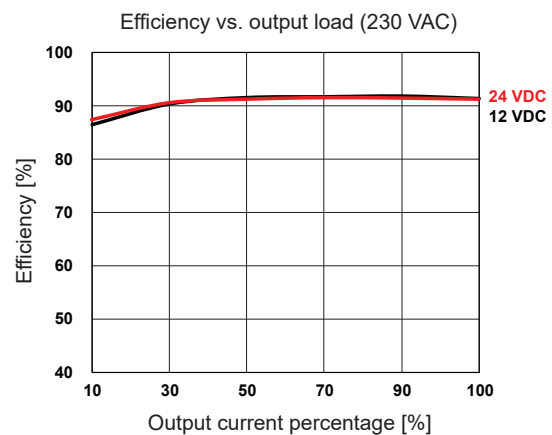

Efficiency (continued)

200 W

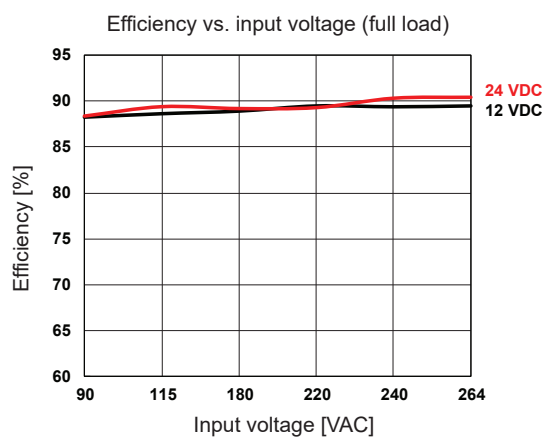
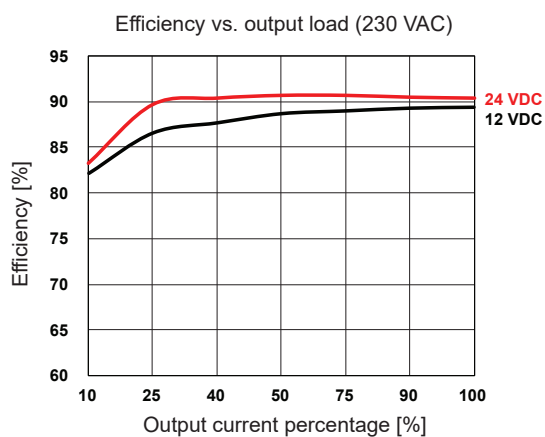

350 W

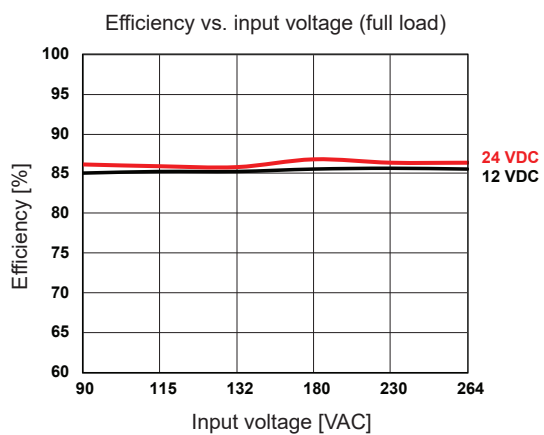
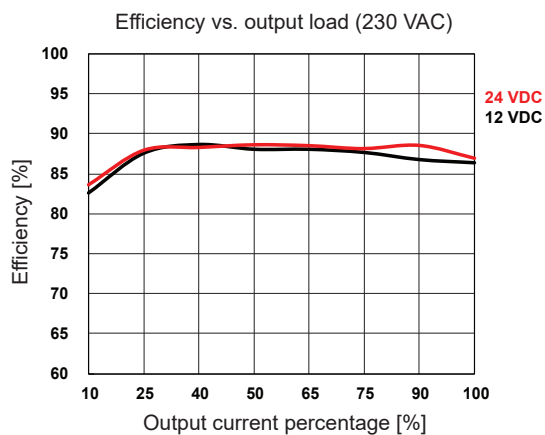

Wiring diagram

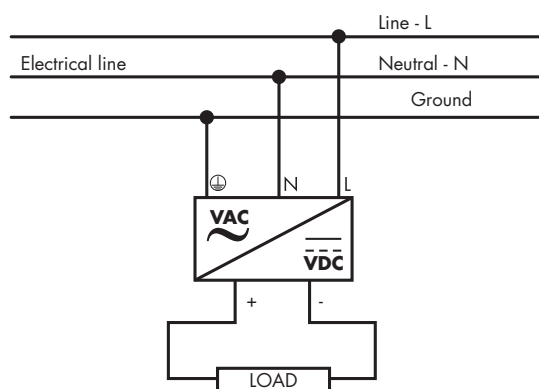

Connection specification

| | | 25 W | 35 W | 50 W | 75 W |
|---|--------|---|------|------|---|
| Terminal type | | Screw terminals with Phillips screw head | | | |
| Screw driver blade | | 3.5 mm slotted or Phillips | | | |
| Tightening torque (recommended) | | 0.4 Nm | | | |
| Conductor cross section (input terminals) | | 0.34 - 2.5 mm ² (22 - 14 AWG) | | | 0.34 - 4 mm ² (22 - 12 AWG) |
| Conductor cross section (PE connection) | | | | | 1.5 - 4 mm ² (16 - 12 AWG)- |
| Conductor cross section (output terminals) | 12 VDC | | | | 0.75 - 4 mm ² (18 - 12 AWG) |
| | 24 VDC | 0.5 - 4 mm ² (20 - 12 AWG) | | | |

| | | 150 W | 200 W | 350 W |
|---|--------|---|--|---|
| Terminal type | | Screw terminals with Phillips screw head | | |
| Screw driver blade | | 3.5 mm slotted or Phillips | | |
| Tightening torque (recommended) | | 0.4 Nm | | |
| Conductor cross section (input terminals) | | 0.5 - 6 mm ² (20 - 10 AWG) | | |
| Conductor cross section (PE connection) | | 1.5 - 6 mm ² (16 - 10 AWG) | | |
| Conductor cross section (output terminals) | 12 VDC | 2.5 - 6 mm ² (14 - 10 AWG) | 4 - 6 mm ² (12 - 10 AWG) | 2.5 - 6 mm ² (14 - 10 AWG) |
| | 24 VDC | 0.75 - 6 mm ² (18 - 10 AWG) | 1.5 - 6 mm ² (16 - 10 AWG) | 0.75 - 6 mm ² (18 - 10 AWG) |

Block diagram

SPPE 25 W / 35 W / 50 W / 75 W

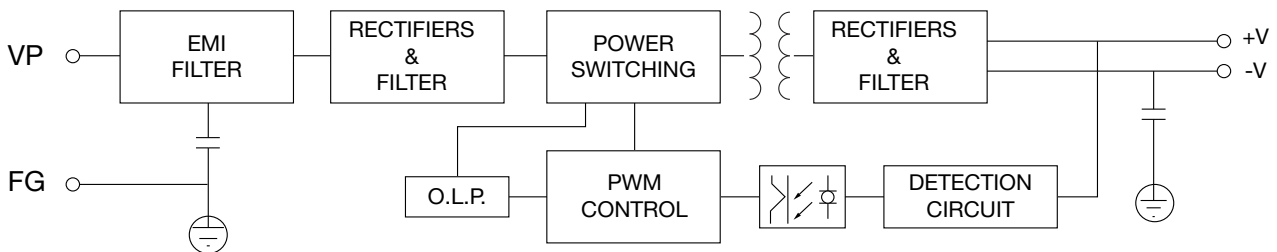

SPPE 150 W

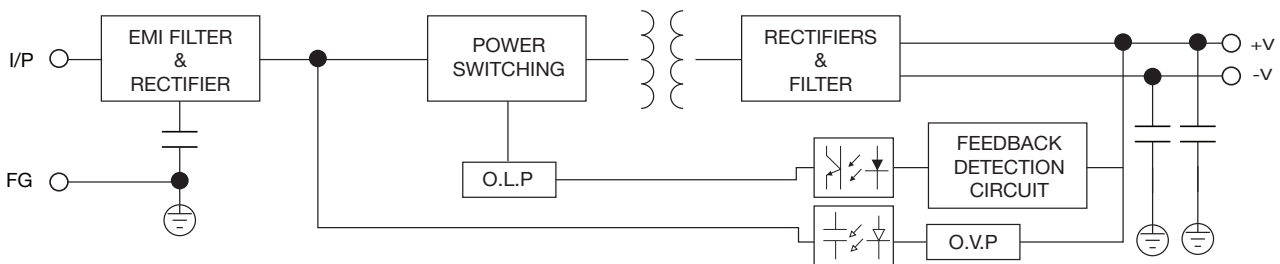

SPPE 200 W / 350 W

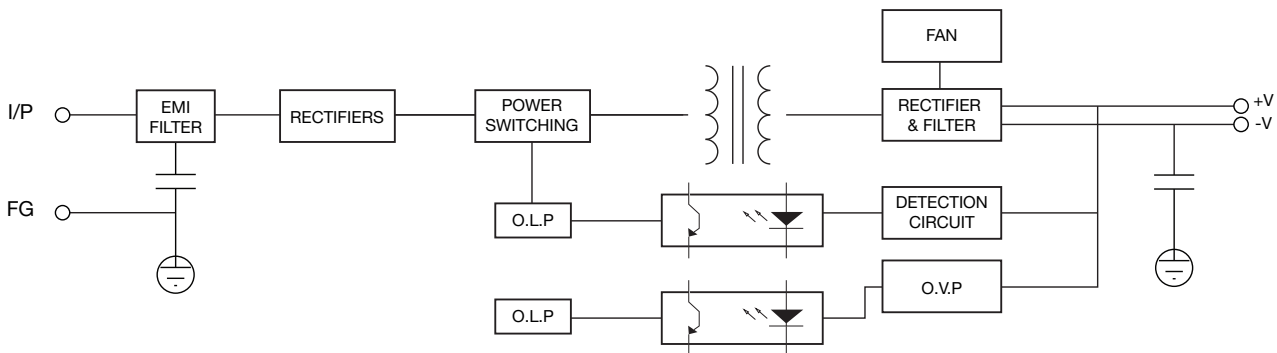

Operating description

Control and protection

| | | 25 W | 35 W | 50 W | 75 W |
|----------------------------|--------|--|---|------|--|
| Overvoltage protection | 12 VDC | ≤ 16.2 VDC Hiccup, self-recovery | ≤ 16.2 VDC Hiccup or clamp, self-recovery | | ≤ 16 VDC Clamp, self-recovery |
| | 24 VDC | ≤ 32.4 VDC Hiccup, self-recovery | ≤ 33.6 VDC Hiccup or clamp, self-recovery | | ≤ 33.6 VDC Hiccup, self-recovery |
| Overcurrent protection | | 110-300% I _o , self-recovery | 120% - 200% I _o , hiccup, self-recovery | | |
| Short circuit protection | | Hiccup, continuous, self-recovery | | | |
| | | Recovery time < 5 s, after the short circuit disappear | Recovery time < 3 s, after the short circuit disappear | | Recovery time < 5 s, after the short circuit disappear |
| Overtemperature protection | | - | | | |

| | | 150 W | 200 W | 350 W |
|----------------------------|--------|---|--|---|
| Overvoltage protection | 12 VDC | ≤ 16 VDC Hiccup or clamp, self-recovery | ≤ 16.2 VDC Hiccup or clamp, self-recovery after fault elimination | ≤ 16.2 VDC Hiccup, self-recovery |
| | 24 VDC | ≤ 33.6 VDC Hiccup or clamp, self-recovery | ≤ 33.6 VDC Hiccup or clamp, self-recovery after fault elimination | ≤ 33.6 VDC Hiccup or clamp, self-recovery |
| Overcurrent protection | | 120% - 200% I _o , hiccup, self-recovery | 120% - 250% I _o , hiccup, self-recovery after fault elimination | 130-220% I _o , self-recovery |
| Short circuit protection | | Hiccup, continuous, self-recovery | | |
| | | - | Recovery time < 5 s, after the short circuit disappear | - |
| Overtemperature protection | | Output voltage turn off, self- recovery | Output voltage turn off, self-recovery after fault elimination | Hiccup, self-recovery |