

LL3-TY01

LL3

FIBERS

SICK
Sensor Intelligence.



Ordering information

Type	Part no.
LL3-TY01	5308066

Included in delivery: FC (1)

Other models and accessories → www.sick.com/LL3

Detailed technical data

Features

Device type	Fibers, fiber suitable for WLL260
Functional principle	Through-beam system
Functional principle detail	Consisting of a sender and a receiver
For fiber-optic sensor	GLL170(T), WLL180, WLL24 Ex, WLL80
Fiber length	2,000 mm
Fiber material	Polymethylmethacrylat (PMMA)
Jacket material	Polytetrafluorethylen (PTFE)
Fiber head material	Polytetrafluorethylen (PTFE)
Outer diameter, fiber-optic cable connection	2.2 mm
Fiber-optic cable cuttable	✓
Smooth sleeve diameter (greatest diameter)	6 mm
Fiber-optic head design	Smooth sleeve
Fiber arrangement	Monofiber
Core structure	Ø 1,0 mm Monofiber
Angle of dispersion < 60°	Yes
Compatibility with infrared light (1,450 nm)	No
Application	Resistant to oil/chemicals
Highly flexible/elastic fibers (bend radius 1–4 mm)	No
Adapter end sleeves required	No
Angle of dispersion	34.45°
Integrated lens	Yes
Minimal object diameter	0.3 mm ¹⁾
Included with delivery	FC fiber cutter (5304141)
Compatibility tip adapters	No
Special features	Teflon sheathing: chemically resistant

¹⁾ Minimum detectable object was determined at optimum measuring distance and optimum setting.

Mechanics/electronics

Bend radius, fibre-optic cable	60 mm
Ambient operating temperature	-40 °C ... +70 °C

Classifications

ECLASS 5.0	27270905
ECLASS 5.1.4	27270905
ECLASS 6.0	27270905
ECLASS 6.2	27270905
ECLASS 7.0	27270905
ECLASS 8.0	27270905
ECLASS 8.1	27270905
ECLASS 9.0	27270905
ECLASS 10.0	27270905
ECLASS 11.0	27270905
ECLASS 12.0	27270905
ETIM 5.0	EC002651
ETIM 6.0	EC002651
ETIM 7.0	EC002651
ETIM 8.0	EC002651
UNSPSC 16.0901	39121528

Sensing ranges with WLL80

Operating mode 16 μs	620 mm
Operating mode 70 μs	1,760 mm
Operating mode 250 μs	2,905 mm
Operating mode 500 μs	3,500 mm
Operating mode 1 ms	3,600 mm
Operating mode 2 ms	3,600 mm
Operating mode 8 ms	3,600 mm

Sensing ranges with WLL180T

Operating mode 16 μs	400 mm
Operating mode 70 μs	1,200 mm
Operating mode 250 μs	2,100 mm
Operating mode 2 ms	4,000 mm
Operating mode 8 ms	4,000 mm
Note	Sensing ranges related to fiber-optic sensors with type of light: visible red light

Sensing ranges with GLL170

Operating mode 250 μs	870 mm
---	--------

Sensing ranges with GLL170T

Operating mode 50 μs	800 mm
Operating mode 250 μs	1,370 mm

Dimensional drawing (Dimensions in mm (inch))

LL3-TY01

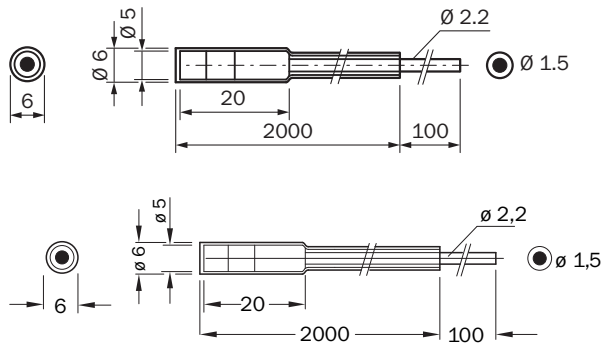

SICK AT A GLANCE

SICK is one of the leading manufacturers of intelligent sensors and sensor solutions for industrial applications. A unique range of products and services creates the perfect basis for controlling processes securely and efficiently, protecting individuals from accidents and preventing damage to the environment.

We have extensive experience in a wide range of industries and understand their processes and requirements. With intelligent sensors, we can deliver exactly what our customers need. In application centers in Europe, Asia and North America, system solutions are tested and optimized in accordance with customer specifications. All this makes us a reliable supplier and development partner.

Comprehensive services complete our offering: SICK LifeTime Services provide support throughout the machine life cycle and ensure safety and productivity.

For us, that is “Sensor Intelligence.”

WORLDWIDE PRESENCE:

Contacts and other locations –www.sick.com