



Q2XABFF Fixed Field Sensor Product Manual

Original Instructions

p/n: 235660 Rev. F

21-Apr-26

© Banner Engineering Corp. All rights reserved. www.bannerengineering.com

Contents

Chapter 1 Features	3
Models	3
Overview.....	4
Chapter 2 Installation	5
Sensor Orientation.....	5
Tilt the Sensor for Shiny Targets.....	5
Mount the Device.....	5
Q2X Fixed Field Wiring Diagrams	6
Chapter 3 Specifications	7
FCC Part 15 Class B for Unintentional Radiators.....	7
Industry Canada ICES-003(B).....	8
Dimensions	8
Performance Curves.....	9
Chapter 4 Accessories	11
Cordsets	11
Brackets.....	12
Chapter 5 Product Support and Maintenance	13
Clean with Mild Detergent and Warm Water	13
Repairs	13
Contact Us.....	13
Banner Engineering Corp Limited Warranty	13

Chapter Contents

Models 3
 Overview 4

Chapter 1 Features

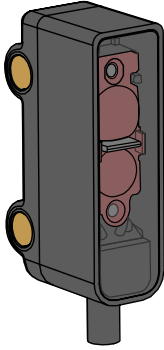

- Compact sensor for installation in the smallest of spaces
- Background suppression models for reliable detection of objects when the background condition is not controlled or fixed
- Enhanced immunity to fluorescent lights
- Crosstalk immunity algorithm allows two sensors to be used in close proximity
- Small visible red LED

WARNING:



- **Do not use this device for personnel protection**
- Using this device for personnel protection could result in serious injury or death.
- This device does not include the self-checking redundant circuitry necessary to allow its use in personnel safety applications. A device failure or malfunction can cause either an energized (on) or de-energized (off) output condition.

Models

Model Number	Range	Spot Size	Connection	Output
Q2XABFF15-Q	15 mm (0.6 in) cutoff	1.2 mm at 15 mm	150 mm (6 in) PVC-jacketed cable with a 4-pin M8 male quick-disconnect connector	Bipolar Light Operate (LO)
Q2XABFF30-Q	30 mm (1.2 in) cutoff	2.2 mm at 30 mm		
Q2XABFF50-Q	50 mm (2 in) cutoff	3.6 mm at 50 mm		
Q2XABFF75-Q	75 mm (2.95 in) cutoff	5.8 mm at 75 mm		
Q2XABFFVS30-Q	30 mm (1.2 in) cutoff	0.9 mm at 15 mm		
Q2XABFFVS50-Q	50 mm (2 in) cutoff	1.7 mm at 30 mm		

To order the sensor model with a 2 m (6.6 ft) cable and flying leads, replace **Q** with **2M**.

To order the sensor model with a 150 mm (6 in) PVC cable and a 4-pin M12 quick disconnect connector, replace **Q** with **Q5**.

In light operate (LO) mode, the output is ON when the target returns the same or more light to the sensor and OFF when the sensor detects less light than the configured/taught target. In **fixed-field** sensing modes, light operate is active when the target is present and dark operate is active when the target is absent.

Overview

The Q2X Fixed Field Sensor ignores objects beyond the set cutoff distance. This sensor can be used in most situations with varying object color and position or with varying background conditions.

Sensor features

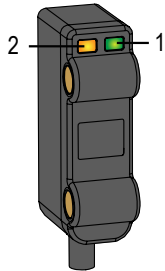

1. Green: Power indicator
2. Amber: Light-sensed indicator (flashes for marginal conditions)

Chapter Contents

Sensor Orientation 5
 Tilt the Sensor for Shiny Targets 5
 Mount the Device 5
 Q2X Fixed Field Wiring Diagrams 6

Chapter 2 Installation

Sensor Orientation

To ensure reliable detection, orient the sensor as shown in relation to the target to be detected.

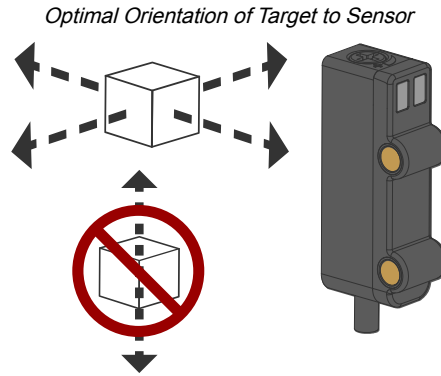

Tilt the Sensor for Shiny Targets

To detect shiny targets, like unfinished metal, tilt the sensor 5° to 15°. The orientation of the sensor is important. Angle the connector up, so the specular reflection bounces away from the receiver.

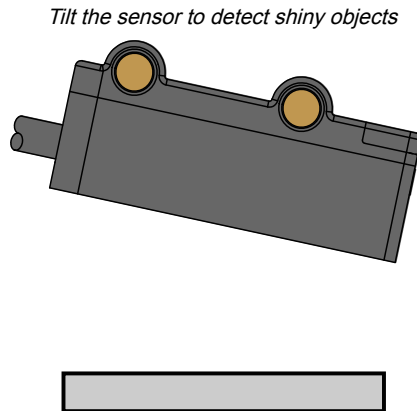

Mount the Device

1. If a bracket is needed, mount the device onto the bracket.
2. Mount the device (or the device and the bracket) to the machine or equipment at the desired location. Do not tighten the mounting screws at this time.
3. Check the device alignment.
4. Tighten the mounting screws to secure the device (or the device and the bracket) in the aligned position.

Q2X Fixed Field Wiring Diagrams

Cabled wiring diagrams are shown. Quick disconnect wiring diagrams are functionally identical.



CAUTION: Observe proper ESD precautions (grounding) when connecting quick disconnect models.

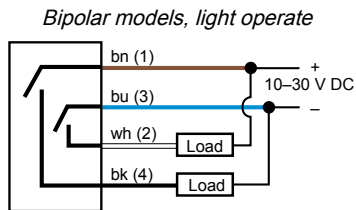

4-pin M8 Male Quick Disconnect	4-pin M12 Male Quick Disconnect	Key
		<p>1 = Brown 2 = White 3 = Blue 4 = Black</p>

Chapter Contents

FCC Part 15 Class B for Unintentional Radiators 7
 Industry Canada ICES-003(B)..... 8
 Dimensions..... 8
 Performance Curves 9

Chapter 3 Specifications

Supply Voltage

10 V DC to 30 V DC (10% maximum ripple within specified limits) at less than 16 mA, exclusive of load

Supply Protection Circuitry

Protected against reverse polarity and transient voltages

Sensing Beam

Visible red LED, 645 nm

Output Configuration

Bipolar (1 NPN and 1 PNP)

Rating: 50 mA total output current

Off-state leakage current: < 10 µA at 30 V DC

ON-state saturation voltage: < 2 V at 50 mA

Protected against output short-circuit, continuous overload, and false pulse on power-up

Output Response

850 microseconds, OFF to ON and ON to OFF

Note: 120-millisecond delay on power-up; outputs do not conduct during this time

Repeatability

125 µs

Adjustments

None

Certifications



Banner Engineering BV
 Park Lane, Culliganlaan 2F bus 3
 1831 Diegem, BELGIUM



Turck Banner LTD Blenheim House
 Blenheim Court
 Wickford, Essex SS11 8YT
 GREAT BRITAIN



Industrial Control Equipment
 LISTED 3TJJ

Connections

2 m (6.5 ft) unterminated 3-wire PVC-jacketed cable, 150 mm (6 in) PVC-jacketed cable with a 4-pin M8 male quick-disconnect connector, or 150 mm (6 in) PVC-jacketed cable with a 4-pin M12 male quick-disconnect connector, depending on model.

Construction

PC/ABS housing, acrylic lens cover; PVC cable

Indicators

Two LED indicators on sensor top:

Green solid: Power on

Amber solid: Light sensed

Amber flashing: Marginal sensing condition

Environmental Rating

IP65, IP67

Operating Conditions

95% at +50 °C maximum relative humidity (non-condensing)

Temperature: -25 °C to +50 °C (-13 °F to +122 °F)

Application Notes

For mirror-like objects, minimize the sensor-to-object mounting distance and tilt the sensor so reflected light is directed away from the sensor when the object is present

Required Overcurrent Protection

WARNING: Electrical connections must be made by qualified personnel in accordance with local and national electrical codes and regulations.

Overcurrent protection is required to be provided by end product application per the supplied table.

Overcurrent protection may be provided with external fusing or via Current Limiting, Class 2 Power Supply.

Supply wiring leads < 24 AWG shall not be spliced.

For additional product support, go to www.bannerengineering.com.

Supply Wiring (AWG)	Required Overcurrent Protection (A)	Supply Wiring (AWG)	Required Overcurrent Protection (A)
20	5.0	26	1.0
22	3.0	28	0.8
24	2.0	30	0.5

FCC Part 15 Class B for Unintentional Radiators

(Part 15.105(b)) This equipment has been tested and found to comply with the limits for a Class B digital device, pursuant to part 15 of the FCC Rules. These limits are designed to provide reasonable protection against harmful interference in a residential installation. This equipment generates, uses, and can radiate radio frequency energy and, if not installed and used in accordance with the instructions, may cause harmful interference to radio communications. However,

there is no guarantee that interference will not occur in a particular installation. If this equipment does cause harmful interference to radio or television reception, which can be determined by turning the equipment off and on, the user is encouraged to try to correct the interference by one or more of the following measures:

- Reorient or relocate the receiving antenna.
- Increase the separation between the equipment and receiver.
- Connect the equipment into an outlet on a circuit different from that to which the receiver is connected.
- Consult the dealer or an experienced radio/TV technician for help.

(Part 15.21) Any changes or modifications not expressly approved by the party responsible for compliance could void the user's authority to operate this equipment.

Industry Canada ICES-003(B)

This device complies with CAN ICES-3 (B)/NMB-3(B). Operation is subject to the following two conditions: 1) This device may not cause harmful interference; and 2) This device must accept any interference received, including interference that may cause undesired operation.

Cet appareil est conforme à la norme NMB-3(B). Le fonctionnement est soumis aux deux conditions suivantes : (1) ce dispositif ne peut pas occasionner d'interférences, et (2) il doit tolérer toute interférence, y compris celles susceptibles de provoquer un fonctionnement non souhaité du dispositif.

Dimensions

All measurements are listed in millimeters [inches], unless noted otherwise. The measurements provided are subject to change.

Dimensions

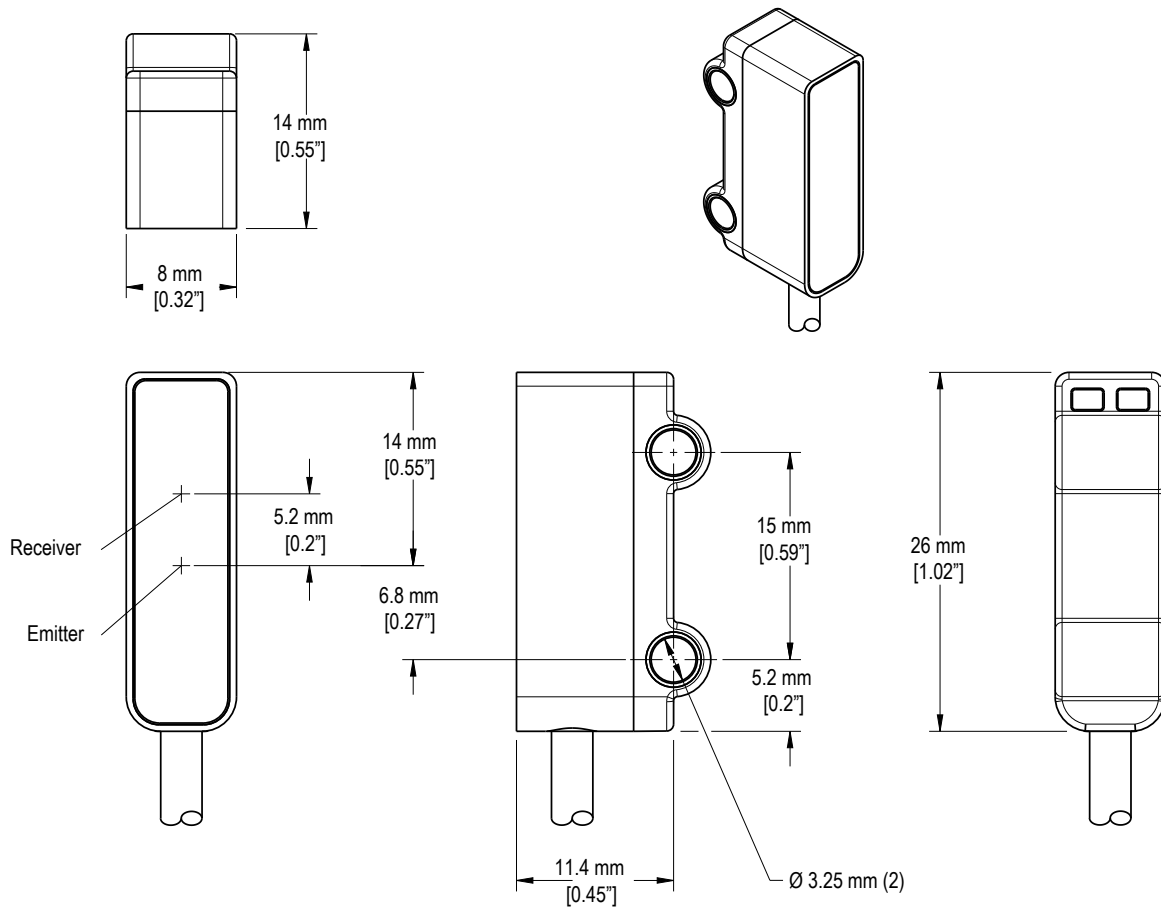

Maximum torque 0.9 Nm (8 in-lbf)

Performance Curves

Excess Gain (15 mm Q2XABFF15-xx Models)

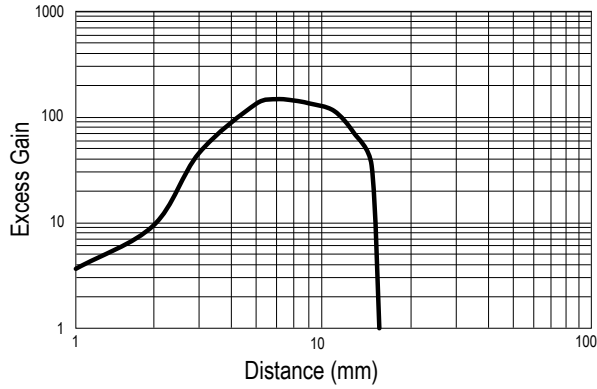

Typical Performance

Spot size: 1.2 mm at 15 mm

Cutoff variation due to 90%/6% color shift ≤ 0.5 mm

Excess Gain (30 mm Q2XABFF30-xx Models)

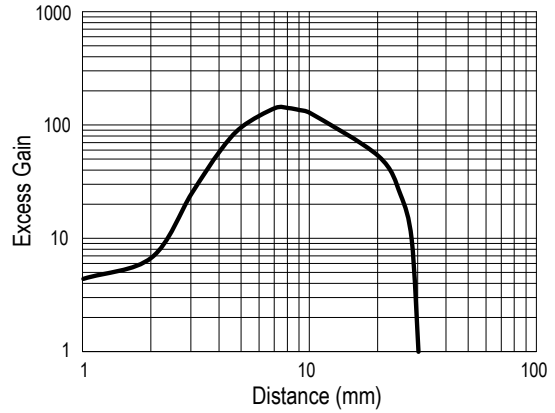

Typical Performance

Spot size: 2.2 mm at 30 mm

Cutoff variation due to 90%/6% color shift ≤ 0.75 mm

Excess Gain (50 mm Q2XABFF50-xx Models)

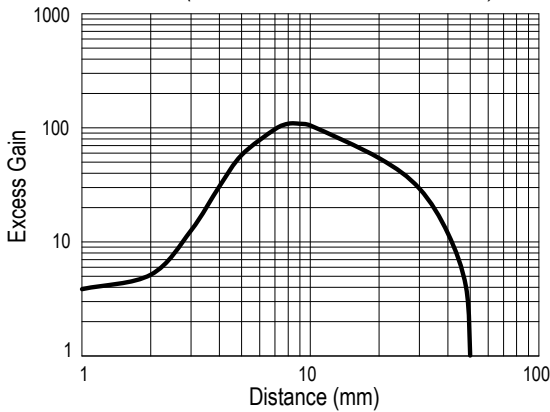

Typical Performance

Spot size: 3.6 mm at 50 mm

Cutoff variation due to 90%/6% color shift ≤ 2.5 mm

Excess Gain (75 mm Q2XABFF75-xx Models)

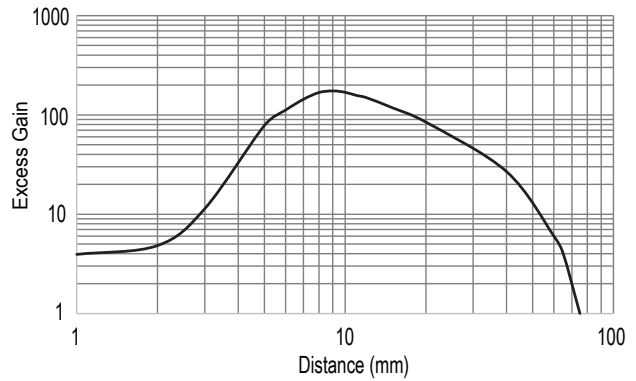

Spot size: 5.8 mm at 75 mm

Cutoff variation due to 90%/6% color shift ≤ 3.5 mm

Continued on page 9

Continued from page 9

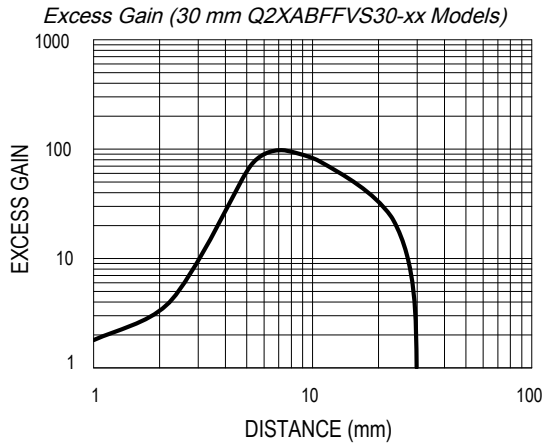

Typical Performance
Spot Size: 0.9 mm at 15 mm
Cutoff variation due to 90%/6% color shift ≤ 0.75 mm

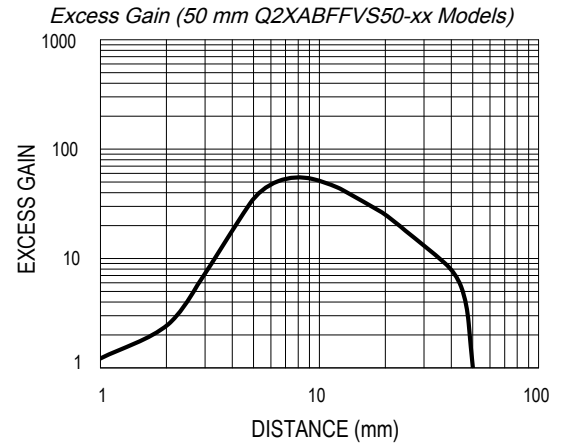

Typical Performance
Spot size: 1.7 mm at 30 mm
Cutoff variation due to 90%/6% color shift ≤ 2.5 mm

Chapter Contents

Cordsets 11
 Brackets 12

Chapter 4 Accessories

Cordsets

4-pin Single-Ended M8 Female Cordsets (datasheet p/n 236623)				
Model	Length	Dimensions (mm)	Pinout (Female)	
BC-M8F4-24-0.5	0.5 m (1.64 ft)			1 = Brown 2 = White 3 = Blue 4 = Black
BC-M8F4-24-1	1 m (3.28 ft)			
BC-M8F4-24-2	2 m (6.56 ft)			
BC-M8F4-24-5	5 m (16.4 ft)			
BC-M8F4-24-8	8 m (26.25 ft)			
BC-M8F4-24-10	10 m (30.81 ft)			

4-pin Single-Ended M12 Female Cordsets (datasheet p/n 235937)				
Model	Length	Dimensions (mm)	Pinout (Female)	
BC-M12F4-22-1	1 m (3.28 ft)			1 = Brown 2 = White 3 = Blue 4 = Black 5 = Unused
BC-M12F4-22-2	2 m (6.56 ft)			
BC-M12F4-22-5	5 m (16.4 ft)			
BC-M12F4-22-8	8 m (26.25 ft)			
BC-M12F4-22-10	10 m (30.81 ft)			
BC-M12F4-22-15	15 m (49.2 ft)			
BC-M12F4-22-20	20 m (65.61 ft)			
BC-M12F4-22-25	25 m (82.02 ft)			
BC-M12F4-22-30	30 m (98.42 ft)			

4-pin Single-Ended M12 Female Right-Angle Cordsets (datasheet p/n 235937)				
Model	Length	Dimensions (mm)	Pinout (Female)	
BC-M12F4A-22-1	1 m (3.28 ft)			1 = Brown 2 = White 3 = Blue 4 = Black 5 = Unused
BC-M12F4A-22-2	2 m (6.56 ft)			
BC-M12F4A-22-5	5 m (16.4 ft)			
BC-M12F4A-22-8	8 m (26.25 ft)			
BC-M12F4A-22-10	10 m (30.81 ft)			
BC-M12F4A-22-15	15 m (49.2 ft)			

Brackets

All measurements are listed in millimeters, unless noted otherwise. The measurements provided are subject to change.

SMBQ2XA

- Vertical L-shaped bracket
- 20-ga stainless steel
- CAD Files: [DXF](#), [PDF](#), [IGS](#), [STP](#)

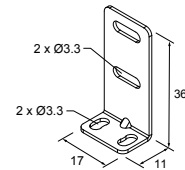

SMBQ2XB

- Rear L-shaped bracket
- 20-ga stainless steel
- CAD Files: [DXF](#), [PDF](#), [IGS](#), [STP](#)

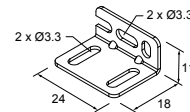

SMBQ20FA

- Includes 3/8-16 x 2 in socket head cap screw (SHCS)
- 304 stainless steel
- CAD Files: [DXF](#), [PDF](#), [IGS](#), [STP](#)

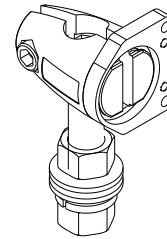

SMBQ20FAM10

- Kit for 10 mm (3/8 in) Rod Bracket Systems for Q2X, Q20, Q12, VS1, VS3, VS8
- Includes M10-1.5 x 50 mm Socket Head Cap Screw (SHCS)
- CAD Files: [DXF](#), [PDF](#), [IGS](#), [STP](#)

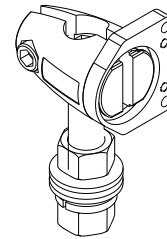

SMBQ20FAM12

- Kit for 12 mm (1/2 in) Rod Bracket Systems for Q2X, Q20, Q12, VS1, VS3, VS8
- No socket head cap screw (SHCS) included
- CAD Files: [DXF](#), [PDF](#), [IGS](#), [STP](#)

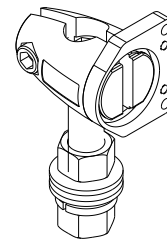

Chapter Contents

Clean with Mild Detergent and Warm Water	13
Repairs	13
Contact Us	13
Banner Engineering Corp Limited Warranty	13

Chapter 5 Product Support and Maintenance

Clean with Mild Detergent and Warm Water

Handle the sensor with care during installation and operation. Sensor windows soiled by fingerprints, dust, water, oil, etc. create stray light that may degrade the peak performance of the sensor.

Wipe down the device with a soft cloth dampened with a mild detergent and warm water solution. Do not use any other chemicals for cleaning.

Repairs

Contact Banner Engineering for troubleshooting of this device. **Do not attempt any repairs to this Banner device; it contains no field-replaceable parts or components.** If the device, device part, or device component is determined to be defective by a Banner Applications Engineer, they will advise you of Banner's RMA (Return Merchandise Authorization) procedure.

IMPORTANT: If instructed to return the device, pack it with care. Damage that occurs in return shipping is not covered by warranty.

Contact Us

Banner Engineering Corp. | 9714 Tenth Avenue North | Plymouth, MN 55441, USA | Phone: + 1 888 373 6767

For worldwide locations and local representatives, visit www.bannerengineering.com.

Banner Engineering Corp Limited Warranty

Banner Engineering Corp. warrants its products to be free from defects in material and workmanship for one year following the date of shipment. Banner Engineering Corp. will repair or replace, free of charge, any product of its manufacture which, at the time it is returned to the factory, is found to have been defective during the warranty period. This warranty does not cover damage or liability for misuse, abuse, or the improper application or installation of the Banner product.

THIS LIMITED WARRANTY IS EXCLUSIVE AND IN LIEU OF ALL OTHER WARRANTIES WHETHER EXPRESS OR IMPLIED (INCLUDING, WITHOUT LIMITATION, ANY WARRANTY OF MERCHANTABILITY OR FITNESS FOR A PARTICULAR PURPOSE), AND WHETHER ARISING UNDER COURSE OF PERFORMANCE, COURSE OF DEALING OR TRADE USAGE.

This Warranty is exclusive and limited to repair or, at the discretion of Banner Engineering Corp., replacement. **IN NO EVENT SHALL BANNER ENGINEERING CORP. BE LIABLE TO BUYER OR ANY OTHER PERSON OR ENTITY FOR ANY EXTRA COSTS, EXPENSES, LOSSES, LOSS OF PROFITS, OR ANY INCIDENTAL, CONSEQUENTIAL OR SPECIAL DAMAGES RESULTING FROM ANY PRODUCT DEFECT OR FROM THE USE OR INABILITY TO USE THE PRODUCT, WHETHER ARISING IN CONTRACT OR WARRANTY, STATUTE, TORT, STRICT LIABILITY, NEGLIGENCE, OR OTHERWISE.**

Banner Engineering Corp. reserves the right to change, modify or improve the design of the product without assuming any obligations or liabilities relating to any product previously manufactured by Banner Engineering Corp. Any misuse, abuse, or improper application or installation of this product or use of the product for personal protection applications when the product is identified as not intended for such purposes will void the product warranty. Any modifications to this product without prior express approval by Banner Engineering Corp will void the product warranties. All specifications published in this document are subject to change; Banner reserves the right to modify product specifications or update documentation at any time. Specifications and product information in English supersede that which is provided in any other language. For the most recent version of any documentation, refer to: www.bannerengineering.com.

For patent information, see www.bannerengineering.com/patents.

