

MDT0200FIH-MULTI	240 x 320	MULTI Interface	TFT Module
Specification			
Version: 1		Date: 18/07/2022	
Revision			
1	16/07/2022	First issue	

Display Features			
Display Size	2.00"		
Resolution	240 x 320		
Orientation	Portrait		
Appearance	RGB		
Logic Voltage	3.3V		
Interface	MCU / SPI		
Brightness	950 cd/m ²		
Touchscreen	---		
Module Size	38.80 x 52.30 x 2.15mm		
Operating Temperature	-20°C ~ +70°C		
Pinout	40 way FFC		Box Quantity
Pitch	0.5mm	Weight / Display	
		---	---

DESIGN • MANUFACTURE • SUPPLY

* - For full design functionality, please use this specification in conjunction with the ST7789VI specification.(Provided Separately)

Display Accessories	
Part Number	Description
MPBV6	40 Way FFC to cable and wires. Driven by any driver board that can be wired to a 1mm pitch SHDR-40V-S-B receptacle.

Optional Variants	
Appearances	Voltage



Summary

TFT 2.0" is a IPS transmissive type color active matrix TFT liquid crystal display that use amorphous silicon TFT as switching devices. This module is composed of a TFT_LCD module, It is usually designed for industrial application and this module follows RoHs.

General Specifications

- Size: 2.0" inch
- Dot Matrix: 240 x RGB x 320(TFT) dots
- Module dimension: 38.8(W) x 52.3(H) x 2.15(D) mm
- Active area: 30.60 x 40.80 mm
- Pixel Pitch: 0.1275 x 0.1275 mm
- LCD type: TFT, Normally Black, Transmissive
- TFT Interface: MCU / SPI
- TFT Driver IC: ST7789VI or Equivalent
- Viewing angle: 80/80/80/80
- Aspect Ratio: 3 : 4
- Backlight Type: LED, Normally White
- With /Without TP: Without TP
- Surface: Glare

*Color tone slight changed by temperature and driving voltage.



Interface

1. LCM PIN Definition

NO	Symbol	Function																																			
1	GND	Ground																																			
2	NC	No connection																																			
3	NC	No connection																																			
4	NC	No connection																																			
5	NC	No connection																																			
6	NC	No connection																																			
7	VDD	Power supply																																			
8	VDDI	Power Supply for I/O System.																																			
9	TE	Tearing effect signal is used to synchronize MCU to frame memory writing. If not used, please let this pin open																																			
10	CSX	Chip selection pin Low enable. High disable.																																			
11	DCX(SCL)	(D/CX): This pin is used to select "Data or Command" in the parallel interface. DCX='1': display data or parameter. DCX='0': command data. (SCL): When SPI mode, This pin is used to be serial interface clock.																																			
12	WRX(D/CX)	Display data/command selection Second Data lane in 2 data lane serial interface. (WRX): Write enable in MCU parallel interface. (D/CX): When 4-SPI mode, This pin in 4-line serial interface If not used, please fix this pin at VDDI or GND.																																			
13	RDX	-Read enable in 8080 MCU parallel interface. -If not used, please fix this pin at VDDI or GND.																																			
14~29	DB0~DB15	Data bus line																																			
30	RESX	System reset pin. signal is active low																																			
31	IM0	The MCU interface mode select. <table border="1" style="width: 100%; border-collapse: collapse; text-align: center;"> <thead> <tr style="background-color: #008000; color: white;"> <th>IM2</th> <th>IM1</th> <th>IM0</th> <th>MPU Interface Mode</th> <th>Data pin</th> </tr> </thead> <tbody> <tr> <td>0</td> <td>0</td> <td>0</td> <td>80-8bit parallel I/F</td> <td>DB[7:0]</td> </tr> <tr> <td>0</td> <td>0</td> <td>1</td> <td>80-16bit parallel I/F</td> <td>DB[15:0]</td> </tr> <tr> <td>0</td> <td>1</td> <td>0</td> <td>80-9bit parallel I/F</td> <td>DB[8:0]</td> </tr> <tr> <td>0</td> <td>1</td> <td>1</td> <td>80-18bit parallel I/F</td> <td>DB[17:0],</td> </tr> <tr> <td>1</td> <td>0</td> <td>1</td> <td>3-line 9bit serial I/F</td> <td>SDA: in/out</td> </tr> <tr> <td>1</td> <td>1</td> <td>0</td> <td>4-line 8bit serial I/F</td> <td>SDA: in/out</td> </tr> </tbody> </table>	IM2	IM1	IM0	MPU Interface Mode	Data pin	0	0	0	80-8bit parallel I/F	DB[7:0]	0	0	1	80-16bit parallel I/F	DB[15:0]	0	1	0	80-9bit parallel I/F	DB[8:0]	0	1	1	80-18bit parallel I/F	DB[17:0],	1	0	1	3-line 9bit serial I/F	SDA: in/out	1	1	0	4-line 8bit serial I/F	SDA: in/out
IM2	IM1		IM0	MPU Interface Mode	Data pin																																
0	0		0	80-8bit parallel I/F	DB[7:0]																																
0	0		1	80-16bit parallel I/F	DB[15:0]																																
0	1		0	80-9bit parallel I/F	DB[8:0]																																
0	1		1	80-18bit parallel I/F	DB[17:0],																																
1	0	1	3-line 9bit serial I/F	SDA: in/out																																	
1	1	0	4-line 8bit serial I/F	SDA: in/out																																	
32	IM1																																				
33	IM2																																				
34~35	DB16~DB17	Data bus line																																			
36	VLED-	Cathode of LED backlight.																																			



37	VLED-	Cathode of LED backlight.
38	VLED+	Anode of LED backlight.
39	NC(SDA)	When SPI mode, This pin is SPI interface input/output pin. The data is latched on the rising edge of the SCL signal. If not used(NC), please fix this pin at VDDI or GND level.
40	NC	No connection

MIDAS

DISPLAYS

DESIGN • MANUFACTURE • SUPPLY



Contour Drawing

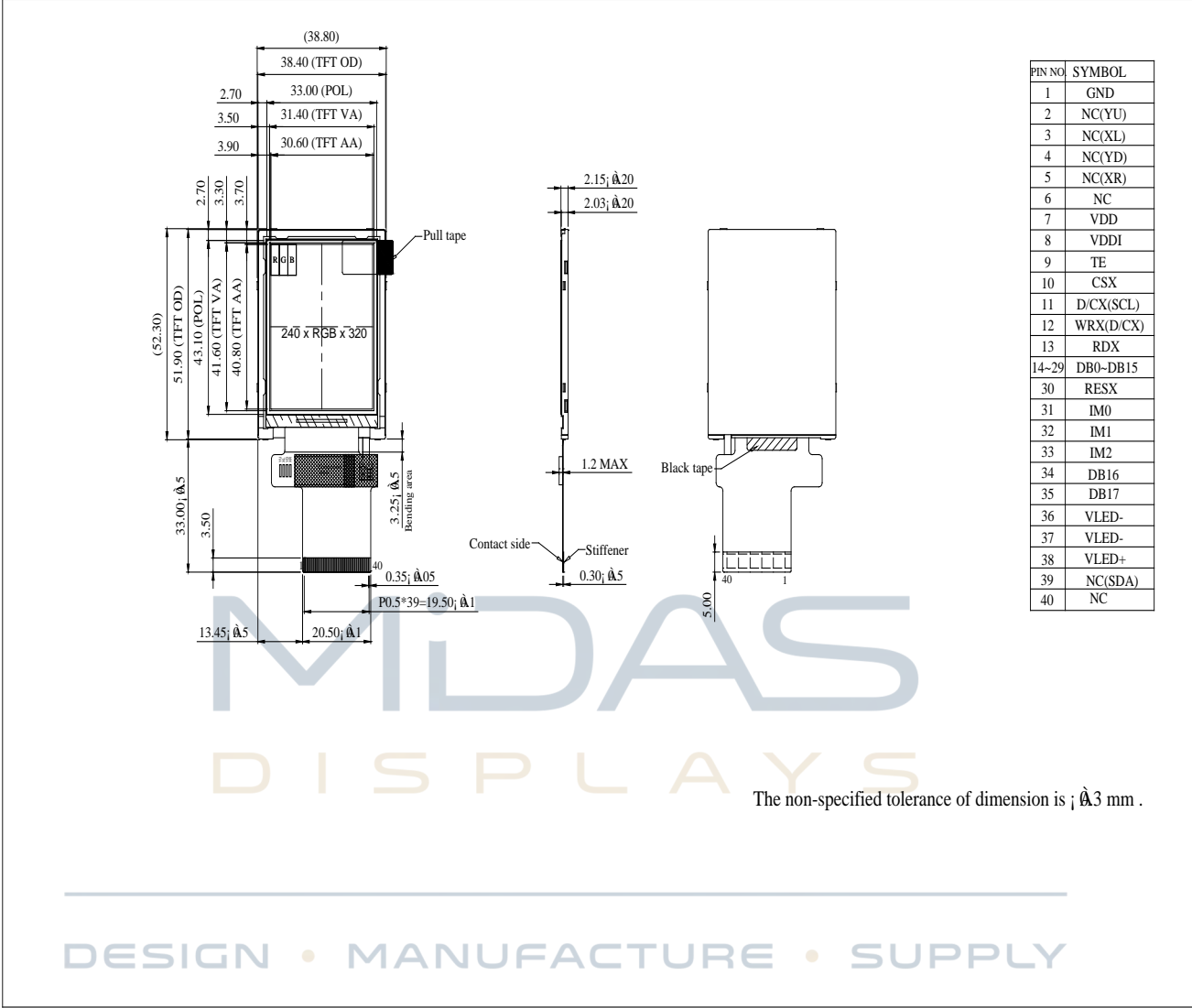

Block Diagram

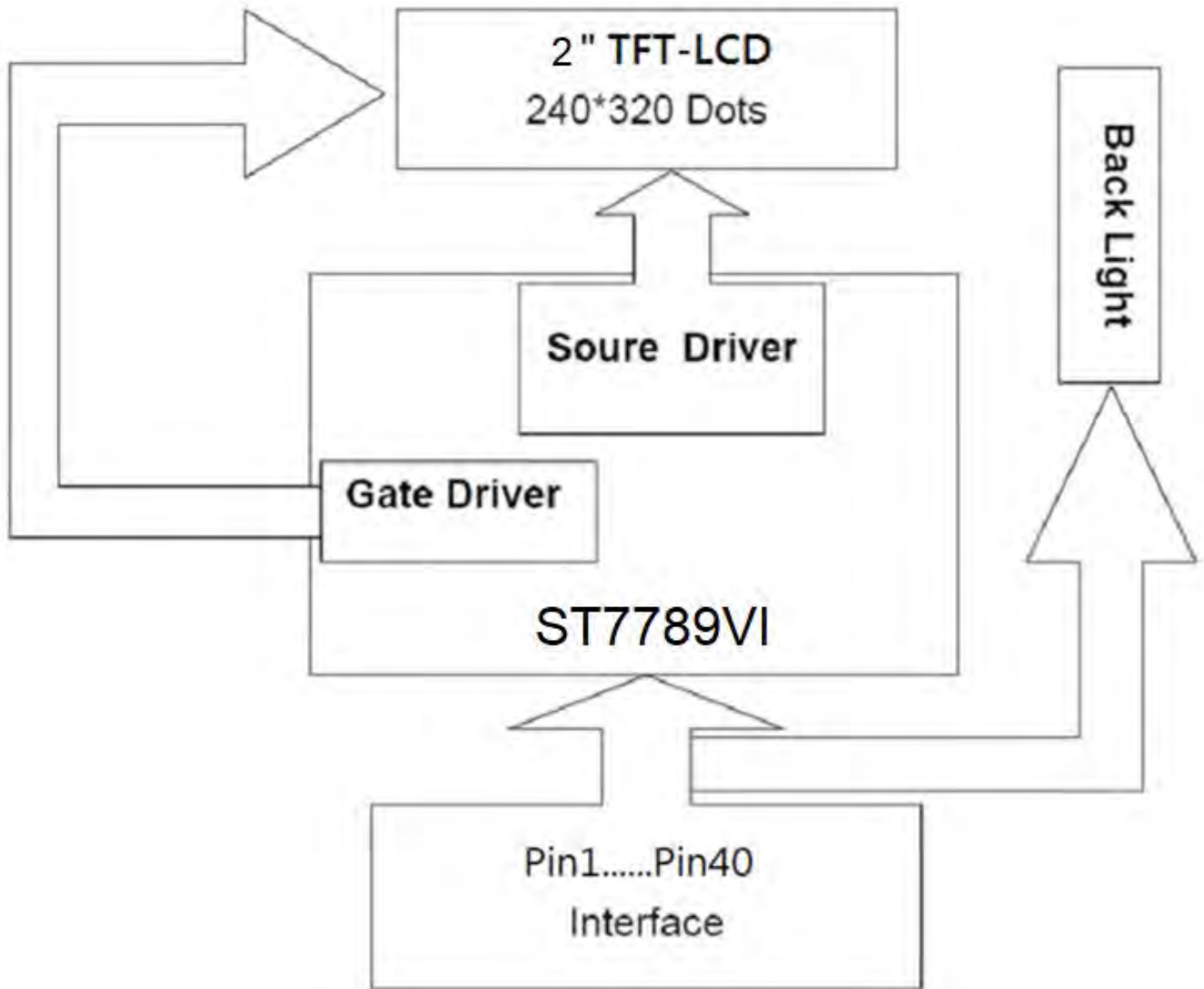

Absolute Maximum Ratings

Item	Symbol	Min	Typ	Max	Unit
Operating Temperature	TOP	-20	—	+70	°C
Storage Temperature	TST	-30	—	+80	°C

Note: Device is subject to be damaged permanently if stresses beyond those absolute maximum ratings listed above

- Temp. $\leq 60^{\circ}\text{C}$, 90% RH MAX. Temp. $> 60^{\circ}\text{C}$, Absolute humidity shall be less than 90% RH at 60°C

Electrical Characteristics

1. Operating conditions

Item	Symbol	Condition	Min	Typ	Max	Unit
Supply Voltage For Analog	V_{DD}	—	2.4	3.3	3.6	V
Interface Operation Voltage	V_{DDI}	—	1.65	1.8	3.6	V
Supply Current For LCM	I_{DD}	$V_{DD} = V_{DDI} = V_{CC} = 3.0\text{V}$	—	6.0	9.0	mA

Note: to avoid power supply noise, please avoid using driving conditions close to min, or max value

2. LED driving conditions

Parameter	Symbol	Min.	Typ.	Max.	Unit	Remark
LED current			60	—	mA	—
LED voltage	V_{LED+}	5.5	6.0	6.5	V	Note 1
LED Life Time	—	—	50,000	—	Hr	Note 2,3,4

Note 1 : There are 1 Groups LED

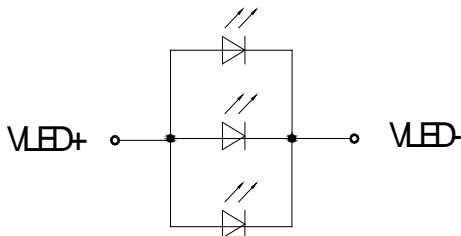

Back Light Circuit

Note 2 : $T_a = 25^{\circ}\text{C}$

Note 3 : Brightness to be decreased to 50% of the initial value

Note 4 : The single LED lamp case



DC Characteristics

Parameter	Symbol	Rating			Unit	Condition
		Min	Typ	Max		
Low level input voltage	V_{IL}	0	-	$0.3V_{CC}$	V	
High level input voltage	V_{IH}	$0.7V_{CC}$	-	V_{CC}	V	

AC Characteristics

1. 8080 Series MCU Parallel Interface Characteristics: 18/16/9/8-bit Bus

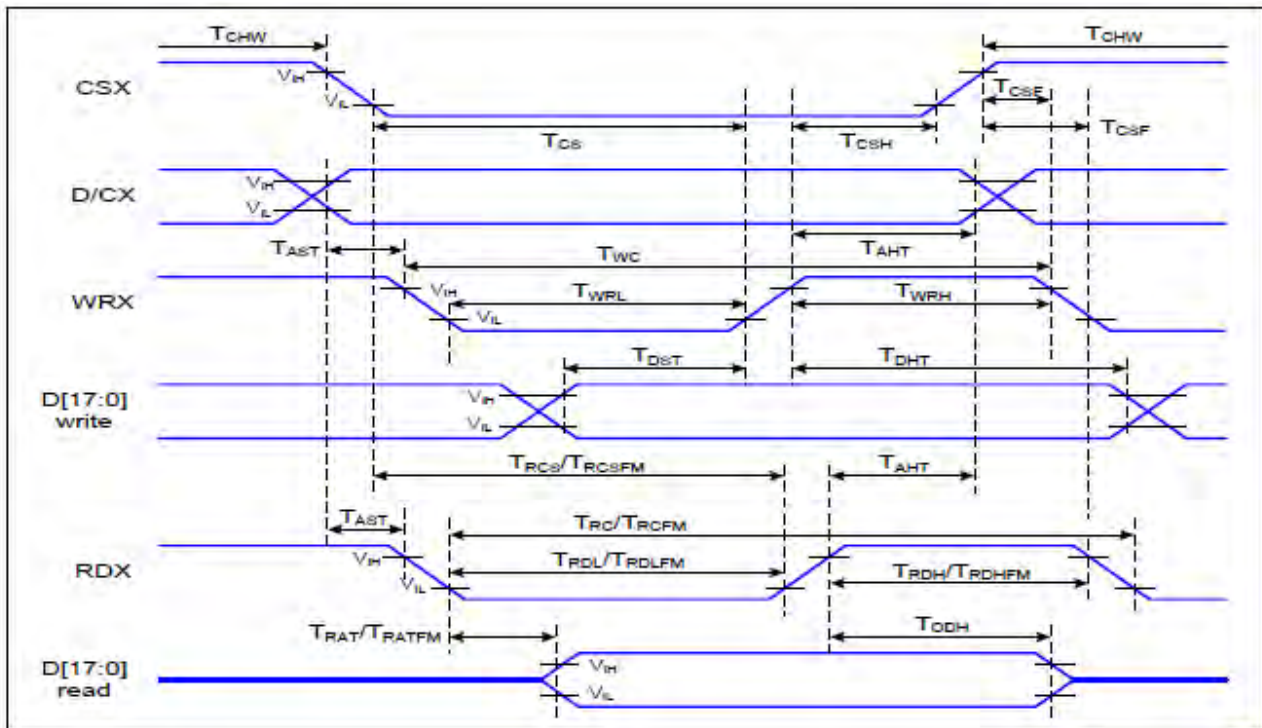

Figure 1 Parallel Interface Timing Characteristics (8080-Series MCU Interface)

VDDI=1.65 to 3.6V, VDD=2.4 to 3.6V, GND=0V, Ta= 25 °C

Signal	Symbol	Parameter	Min	Max	Unit	Description
D/CX	TAST	Address setup time	0		ns	-
	TAHT	Address hold time (Write/Read)	10		ns	
CSX	TCHW	Chip select "H" pulse width	0		ns	-
	TCS	Chip select setup time (Write)	15		ns	
	TRCS	Chip select setup time (Read ID)	45		ns	
	TRCSFM	Chip select setup time (Read FM)	355		ns	
	TCSF	Chip select wait time (Write/Read)	10		ns	
	TCSH	Chip select hold time	10		ns	
WRX	TWC	Write cycle	66		ns	
	TWRH	Control pulse "H" duration	15		ns	
	TWRL	Control pulse "L" duration	15		ns	
RDX (ID)	TRC	Read cycle (ID)	160		ns	When read ID data
	TRDH	Control pulse "H" duration (ID)	90		ns	
	TRDL	Control pulse "L" duration (ID)	45		ns	
RDX (FM)	TRCFM	Read cycle (FM)	450		ns	When read from frame memory
	TRDHFM	Control pulse "H" duration (FM)	90		ns	
	TRDLFM	Control pulse "L" duration (FM)	355		ns	
D[17:0]	TDST	Data setup time	10		ns	For CL=30pF
	T _{DHT}	Data hold time	10		ns	
	T _{RAT}	Read access time (ID)		40	ns	
	T _{RATFM}	Read access time (FM)		340	ns	
	T _{ODH}	Output disable time	20	80	ns	

Table 8080 Parallel Interface Characteristics



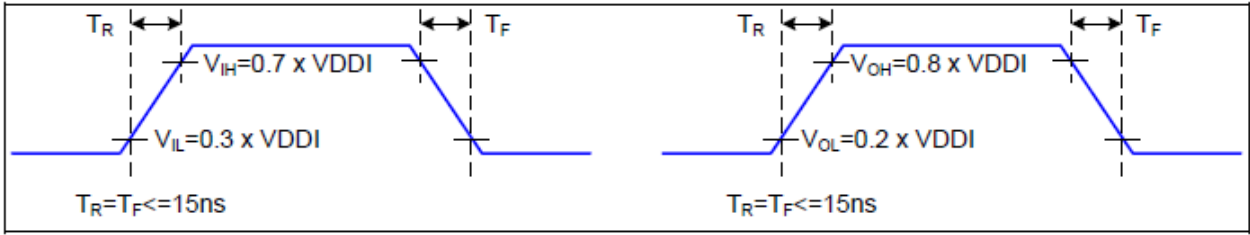

Figure 2 Rising and Falling Timing for I/O Signal

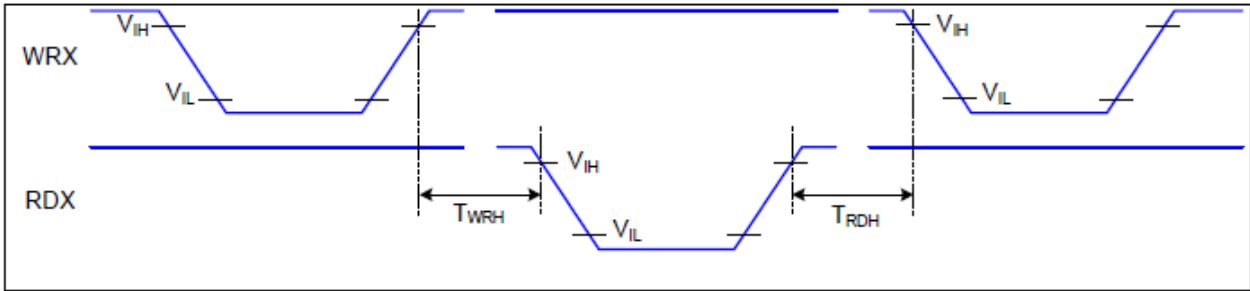

Figure 3 Write-to-Read and Read-to-Write Timing

Note: The rising time and falling time (T_r , T_f) of input signal and fall time are specified at 15 ns or less. Logic high and low levels are specified as 30% and 70% of VDDI for Input signals.

MIDAS
DISPLAYS

DESIGN • MANUFACTURE • SUPPLY



2. 3-line Serial Interface

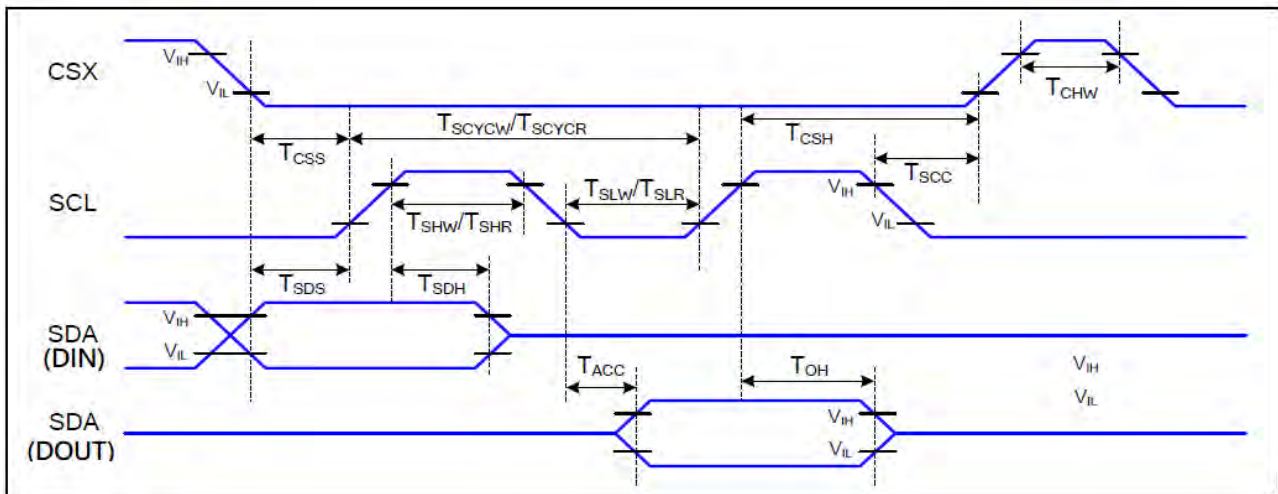

Figure 4 3-line serial Interface Timing Characteristics

VDDI=1.65 to 3.6V, VDD=2.4 to 3.6V, GND=0V, Ta= 25 °C

Signal	Symbol	Parameter	Min	Max	Unit	Description
CSX	T_{CSS}	Chip select setup time (write)	15		ns	
	T_{CSH}	Chip select hold time (write)	15		ns	
	T_{CSS}	Chip select setup time (read)	60		ns	
	T_{SCC}	Chip select hold time (read)	65		ns	
	T_{CHW}	Chip select "H" pulse width	40		ns	
SCL	T_{SCYCW}	Serial clock cycle (Write)	16		ns	
	T_{SHW}	SCL "H" pulse width (Write)	7		ns	
	T_{SLW}	SCL "L" pulse width (Write)	7		ns	
	T_{SCYCR}	Serial clock cycle (Read)	150		ns	
	T_{SHR}	SCL "H" pulse width (Read)	60		ns	
	T_{SLR}	SCL "L" pulse width (Read)	60		ns	
SDA (DIN)	T_{SDS}	Data setup time	7		ns	
	T_{SDH}	Data hold time	7		ns	
SDA (DOUT)	T_{ACC}	Access time	10	50	ns	For maximum CL=30pF
	T_{OH}	Output disable time	15	50	ns	For minimum CL=8pF

Table 3-line serial Interface Characteristics

3. Reset Timing:

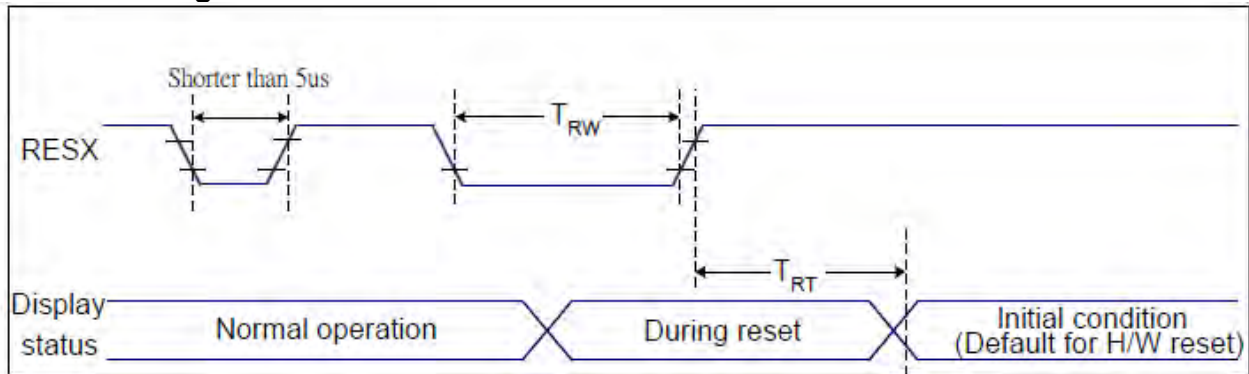

Figure 5 Reset Timing

VDDI=1.65 to 3.6V, VDD=2.4 to 3.6V, GND=0V, Ta=25 °C

Related Pins	Symbol	Parameter	MIN	MAX	Unit
RESX	TRW	Reset pulse duration	10	-	us
	TRT	Reset cancel	-	5 (Note 1, 5)	ms
				120 (Note 1, 6, 7)	ms

Notes:

1. The reset cancel includes also required time for loading ID bytes, VCOM setting and other settings from NVM (or similar device) to registers. This loading is done every time when there is HW reset cancel time (tRT) within 5 ms after a rising edge of RESX.
2. Spike due to an electrostatic discharge on RESXline does not cause irregular system reset according to the table below:

RESX Pulse	Action
Shorter than 5us	Reset Rejected
Longer than 9us	Reset
Between 5us and 9us	Reset starts

3. During the Resetting period, the display will be blanked (The display is entering blanking sequence, which maximum time is 120 ms, when Reset Starts in Sleep Out –mode. The display remains the blank state in Sleep In –mode.) and then return to Default condition for Hardware Reset.

4. Spike Rejection also applies during a valid reset pulse as shown below:

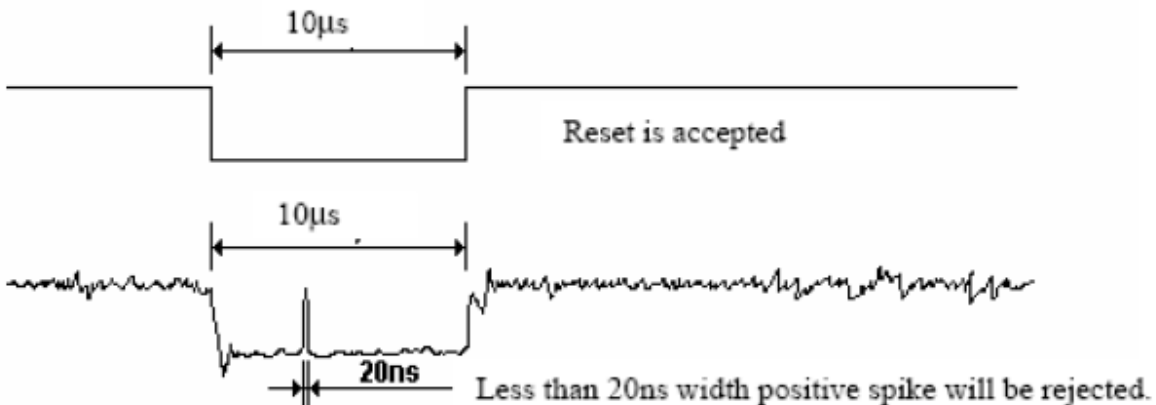

5. When Reset applied during Sleep In Mode.
6. When Reset applied during Sleep Out Mode.
7. It is necessary to wait 5msec after releasing RESX before sending commands. Also Sleep Out command cannot be sent for 120msec.

4. Power sequences

The power on/off sequence is illustrated below

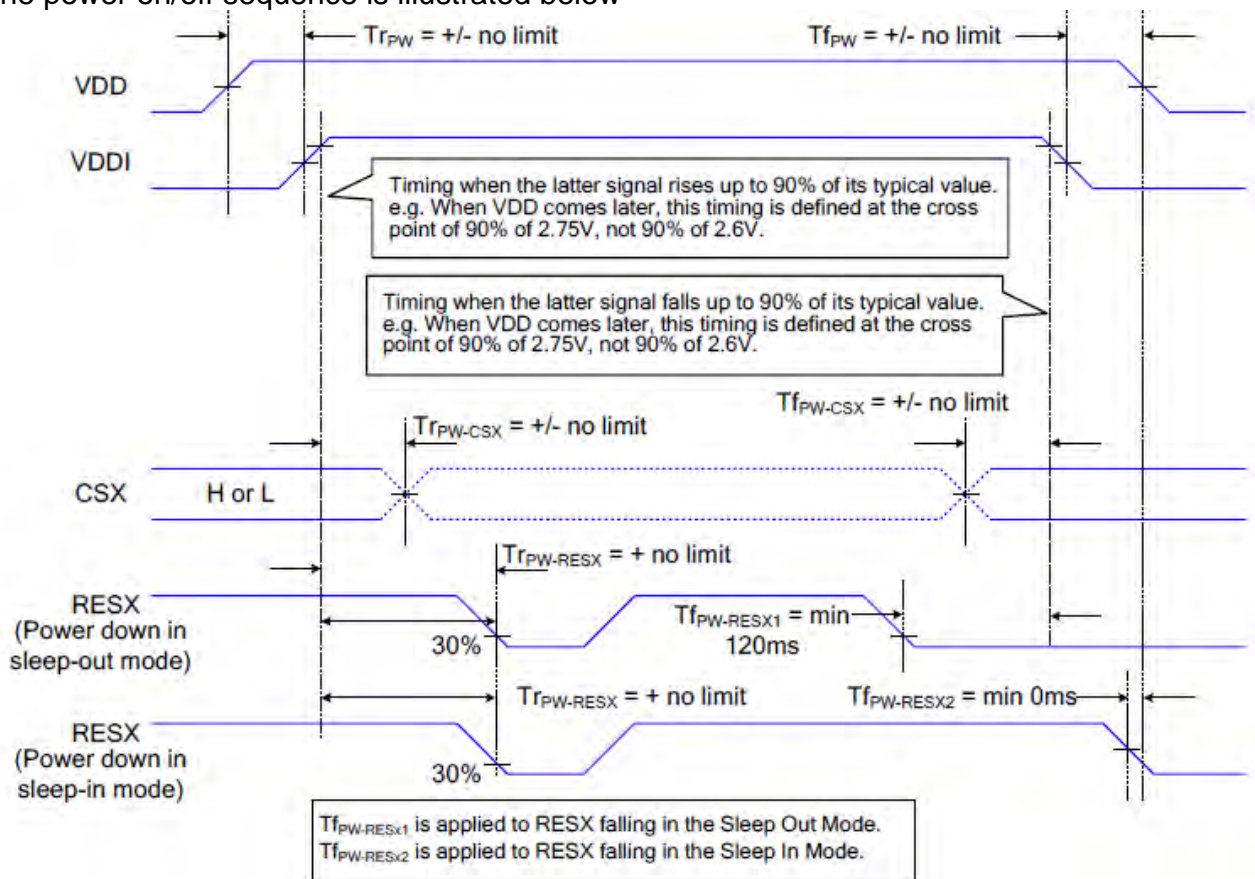

Optical Characteristics

Item	Symbol	Condition.	Min	Typ.	Max.	Unit	Remark	
Response time	Tr+ Tf	$\theta=0^\circ$ 、 $\Phi=0^\circ$	-	35	45	ms	Note 3	
Contrast ratio	CR	At optimized viewing angle	640	800	-	-	Note 4	
Color Chromaticity	White	Wx	$\theta=0^\circ$ 、 $\Phi=0$	0.246	0.296	0.346		Note 2,6,7
		Wy		0.275	0.325	0.375		
Viewing angle (Gray Scale Inversion Direction)	Hor.	Θ_R	$CR \geq 10$	-	80	-	Deg.	Note 1
		Θ_L		-	80	-		
	Ver.	Φ_T		-	80	-		
		Φ_B		-	80	-		
Brightness	-	-	850	950	-	cd/m ²	Center of display	
Uniformity	(U)	-	75	-	-	%	Note5	

Ta=25±2°C

Note 1: Definition of viewing angle range

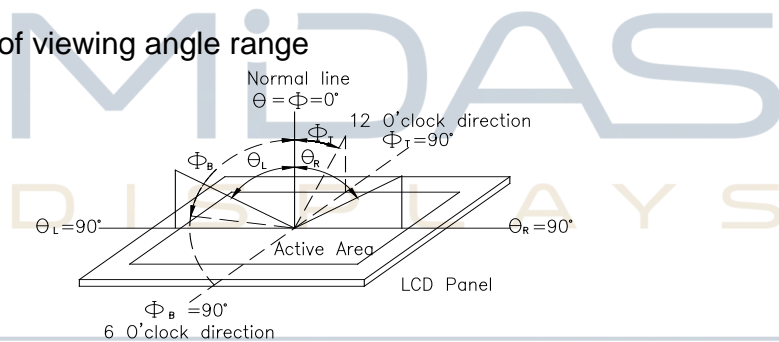

Fig. 11.1. Definition of viewing angle

Note 2: Test equipment setup:

After stabilizing and leaving the panel alone at a driven temperature for 10 minutes, the measurement should be executed. Measurement should be executed in a stable, windless, and dark room. Optical specifications are measured by Topcon BM-7 or BM-5 luminance meter 1.0° field of view at a distance of 50cm and normal direction.

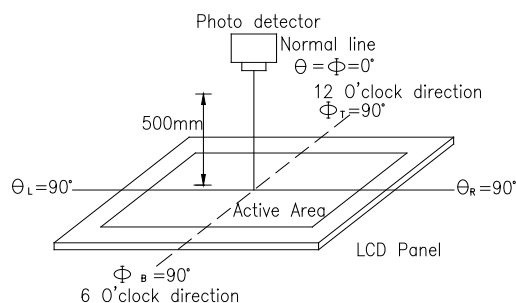
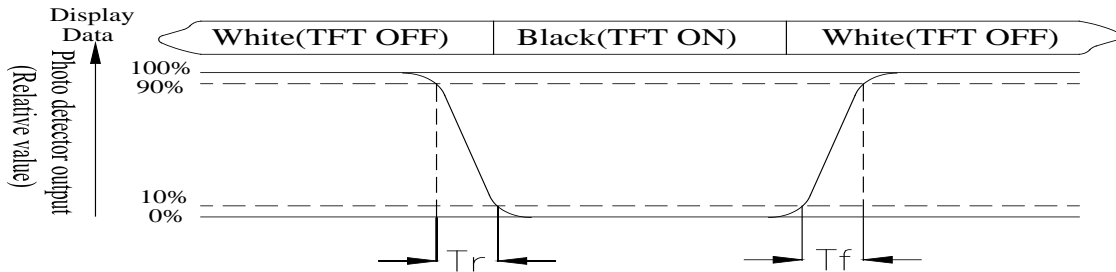

Fig. 11.2. Optical measurement system setup



Note 3: Definition of Response time:

The response time is defined as the LCD optical switching time interval between "White" state and "Black" state. Rise time, T_r , is the time between photo detector output intensity changed from 90% to 10%. And fall time, T_f , is the time between photo detector output intensity changed from 10% to 90%



Note 4: Definition of contrast ratio:

The contrast ratio is defined as the following expression.

$$\text{Contrast ratio (CR)} = \frac{\text{Luminance measured when LCD on the "White" state}}{\text{Luminance measured when LCD on the "Black" state}}$$

Note 5: Definition of Luminance Uniformity

Active area is divided into 9 measuring areas (reference the picture in below). Every measuring point is placed at the center of each measuring area.

$$\text{Luminance Uniformity (U)} = \text{Lmin/Lmax} \times 100\%$$

L = Active area length

W = Active area width

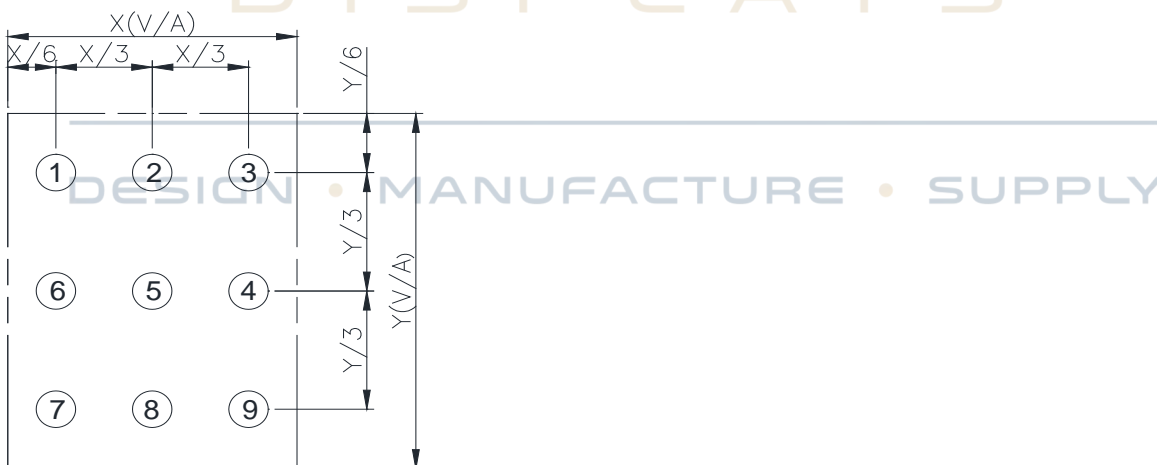

Fig 11.3. Definition of uniformity

Note 6: Definition of color chromaticity (CIE 1931)

Color coordinates measured at the center point of LCD

Note 7: Measured at the center area of the panel when all the input terminals of LCD panel are electrically opened.



Reliability

Content of Reliability Test (Wide temperature, -20°C~70°C)

Environmental Test			
Test Item	Content of Test	Test Condition	Note
High Temperature storage	Endurance test applying the high storage temperature for a long time.	80°C 200hrs	2
Low Temperature storage	Endurance test applying the low storage temperature for a long time.	-30°C 200hrs	1,2
High Temperature Operation	Endurance test applying the electric stress (Voltage & Current) and the thermal stress to the element for a long time.	70°C 200hrs	—
Low Temperature Operation	Endurance test applying the electric stress under low temperature for a long time.	-20°C 200hrs	1
High Temperature/ Humidity Operation	The module should be allowed to stand at 60°C,90%RH max	60°C,90%RH 96hrs	1,2
Thermal shock resistance	<p>The sample should be allowed stand the following 10 cycles of operation</p> <p style="text-align: center;"> -20°C 25°C 70°C ←————→ 30min 5min 30min 1 cycle </p>	-20°C/70°C 10 cycles	—
Vibration test	Endurance test applying the vibration during transportation and using.	Total fixed amplitude : 1.5mm Vibration Frequency : 10~55Hz One cycle 60 seconds to 3 directions of X,Y,Z for Each 15 minutes	3
Static electricity test	Endurance test applying the electric stress to the finished product housing.	Contact±4KV Air±8KV 10 times	4

Note1: No dew condensation to be observed.

Note2: The function test shall be conducted after 4 hours storage at the normal Temperature and humidity after remove from the test chamber.

Note3: The packing have to including into the vibration testing.

Note4: Some performance degradation allowed. Need Power off self-recoverable.No hardware failure



Initial Code For Reference

void ST7789SV_RF0200B(void) for SPI & MCU mode

```
{
    Write_Command(0x11); //Sleep out
        delay(150);          //Delay 120ms

    Write_Command(0x36); //
    Write_Data(0x00);

    Write_Command(0x3A); //
    Write_Data(0x55);

    //ST7789S Frame rate setting
        Write_Command(0xb2); //Porch Setting
        Write_Data(0x0c);
        Write_Data(0x0c);
        Write_Data(0x00);
        Write_Data(0x33);
        Write_Data(0x33);
        Write_Command(0xb7); //Gate Control
        //Write_Data(0x35); //vgh vgl
        Write_Data(0x64);

    //ST7789S Power setting
        Write_Command(0xbb); //Gate Control VCOMS=1.425V
        Write_Data(0x30);
        Write_Command(0xc0); //LCM Control
    Write_Data(0x2c);
        Write_Command(0xc2); //VDV and VRH Command Enable
        Write_Data(0x01);
        Write_Command(0xc3); //VRH Set (AVDD=VRH+1.675
        Write_Data(0x0b);
        Write_Command(0xc4); //VRH Set
        Write_Data(0x20);
        Write_Command(0xc6); //Frame Rate Control in Normal Mode
        Write_Data(0x0f);
        Write_Command(0xca); //Register Value Selection 2
        Write_Data(0x0f);
        Write_Command(0xc8); //Register Value Selection 1
        Write_Data(0x08);
        Write_Command(0x55); //Write Content Adaptive Brightness Control and Color Enhancemen
```



t

```
Write_Data(0x90);  
Write_Command(0xd0); //Power Control  
Write_Data(0xa4);  
Write_Data(0xa1);  
Write_Command(0x35); //
```

```
Write_Command(0x26); //Set Gamma  
Write_Data(0x02);
```

```
//ST7789S gamma setting
```

```
Write_Command(0xe0);  
Write_Data(0xd0);  
Write_Data(0x00);  
Write_Data(0x02);  
Write_Data(0x07);  
Write_Data(0x0b);  
Write_Data(0x1a);  
Write_Data(0x31);  
Write_Data(0x54);  
Write_Data(0x40);  
Write_Data(0x29);  
Write_Data(0x12);  
Write_Data(0x12);  
Write_Data(0x12);  
Write_Data(0x17);  
Write_Command(0xe1);  
Write_Data(0xd0);  
Write_Data(0x00);  
Write_Data(0x02);  
Write_Data(0x07);  
Write_Data(0x05);  
Write_Data(0x25);  
Write_Data(0x2d);  
Write_Data(0x44);  
Write_Data(0x45);  
Write_Data(0x1c);  
Write_Data(0x18);  
Write_Data(0x16);  
Write_Data(0x1c);  
Write_Data(0x1d);
```



Write_Command(0x21);

Write_Command(0x2A);

Write_Data(0x00);

Write_Data(0x00);

Write_Data(0x00);

Write_Data(0xEF);

Write_Command(0x2B);

Write_Data(0x00);

Write_Data(0x0);

Write_Data(0x01);

Write_Data(0x3F);

Write_Command(0x29);

}

MIDAS
DISPLAYS

DESIGN • MANUFACTURE • SUPPLY

