

# IGBT – Power, Co-PAK N-Channel, Field Stop VII (FS7), SCR, TO247-3L

1200 V, 1.5 V, 60 A

## FGHL60T120RWD

### Description

Using the novel field stop 7th generation IGBT technology and the Gen7 Diode in TO247 3-lead package, FGHL60T120RWD offers the optimum performance with low conduction losses and good switching controllability for a high efficiency operation in various applications like motor control, UPS, data center and high-power switch.

### Features

- Low Conduction Loss and Optimized Switching
- Maximum Junction Temperature –  $T_J = 175^\circ\text{C}$
- Positive Temperature Coefficient for Easy Parallel Operation
- High Current Capability
- 100% of the Parts are Dynamically Tested
- Short Circuit Rated
- RoHS Compliant

### Applications

- Motor Control
- UPS
- General Application Requiring High Power Switch

### MAXIMUM RATINGS ( $T_J = 25^\circ\text{C}$ unless otherwise noted)

Parameter		Symbol	Value	Unit
Collector-to-Emitter Voltage		$V_{CES}$	1200	V
Gate-to-Emitter Voltage		$V_{GES}$	$\pm 20$	
Transient Gate-to-Emitter Voltage			$\pm 30$	
Collector Current	$T_C = 25^\circ\text{C}$ (Note 1)	$I_C$	120	A
	$T_C = 100^\circ\text{C}$		60	
Power Dissipation	$T_C = 25^\circ\text{C}$	$P_D$	833	W
	$T_C = 100^\circ\text{C}$		416	
Pulsed Collector Current	$T_C = 25^\circ\text{C}$ (Note 2) $t_p = 10 \mu\text{s}$	$I_{CM}$	180	A
Diode Forward Current	$T_C = 25^\circ\text{C}$ (Note 1)	$I_F$	120	
	$T_C = 100^\circ\text{C}$		60	
Pulsed Diode Maximum Forward Current	$T_C = 25^\circ\text{C}$ , $t_p = 10 \mu\text{s}$	$I_{FM}$	180	
Operating Junction and Storage Temperature Range		$T_J, T_{stg}$	-55 to +175	$^\circ\text{C}$
Lead Temperature for Soldering Purposes		$T_L$	260	

Stresses exceeding those listed in the Maximum Ratings table may damage the device. If any of these limits are exceeded, device functionality should not be assumed, damage may occur and reliability may be affected.

1. Value limit by bond wire.
2. Repetitive rating: Pulse width limited by max. junction temperature.

$BV_{CES}$	$V_{CE(SAT)}$	$I_C$
1200 V	1.5 V	60 A

### PIN CONNECTIONS

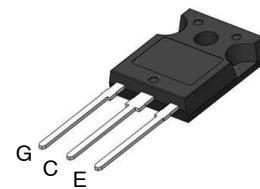
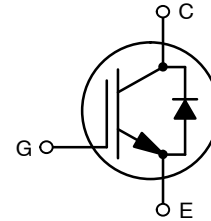

TO-247-3LD  
CASE 340CX

### MARKING DIAGRAM

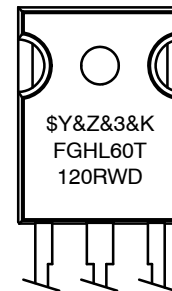

$\$Y$  = onsemi Logo  
 $\&Z$  = Assembly Plant Code  
 $\&3$  = 3-Digit Date Code  
 $\&K$  = 2-Digit Lot Traceability Code  
 FGHL60T120RWD = Specific Device Code

### ORDERING INFORMATION

Device	Package	Shipping
FGHL60T120RWD	TO-247 (Pb-Free)	30 Units / Tube

# FGHL60T120RWD

## THERMAL CHARACTERISTICS

Parameter	Symbol	Value	Unit
Thermal Resistance, Junction-to-Case for IGBT	$R_{\theta JC}$	0.18	°C/W
Thermal Resistance, Junction-to-Case for Diode	$R_{\theta JCD}$	0.33	
Thermal Resistance, Junction-to-Ambient	$R_{\theta JA}$	40	

## ELECTRICAL CHARACTERISTICS OF IGBT ( $T_J = 25^\circ\text{C}$ unless otherwise noted)

Parameter	Symbol	Test Conditions	Min	Typ	Max	Unit
-----------	--------	-----------------	-----	-----	-----	------

### OFF CHARACTERISTICS

Collector-to-Emitter Breakdown Voltage	$BV_{CES}$	$V_{GE} = 0\text{ V}, I_C = 5\text{ mA}$	1200			V
Collector-to-Emitter Breakdown Voltage Temperature Coefficient	$\frac{\Delta BV_{CES}}{\Delta T_J}$			1225		
Zero Gate Voltage Collector Current	$I_{CES}$	$V_{GE} = 0\text{ V}, V_{CE} = V_{CES}$			40	μA
Gate-to-Emitter Leakage Current	$I_{GES}$	$V_{GE} = 20\text{ V}, V_{CE} = 0\text{ V}$			±400	nA

### ON CHARACTERISTICS

Gate Threshold Voltage	$V_{GE(th)}$	$V_{GE} = V_{CE}, I_C = 60\text{ mA}, T_J = 25^\circ\text{C}$	4.9	5.94	6.7	V
Collector-to-Emitter Saturation Voltage	$V_{CE(sat)}$	$V_{GE} = 15\text{ V}, I_C = 60\text{ A}, T_J = 25^\circ\text{C}$	1.2	1.48	1.8	
		$V_{GE} = 15\text{ V}, I_C = 60\text{ A}, T_J = 175^\circ\text{C}$		1.81		

### DYNAMIC CHARACTERISTICS

Input Capacitance	$C_{ies}$	$V_{CE} = 30\text{ V}, V_{GE} = 0\text{ V}, f = 1\text{ MHz}$		7128		pF
Output Capacitance	$C_{oes}$			252		
Reverse Transfer Capacitance	$C_{res}$			25.3		
Total Gate Charge	$Q_g$	$V_{CE} = 600\text{ V}, V_{GE} = 15\text{ V}, I_C = 60\text{ A}$		256		nC
Gate-to-Emitter Charge	$Q_{ge}$			64.1		
Gate-to-Collector Charge	$Q_{gc}$			102		

### SWITCHING CHARACTERISTICS

Turn-on Delay Time	$t_{d(on)}$	$V_{CE} = 600\text{ V}, V_{GE} = 0/15\text{ V}, I_C = 30\text{ A}, R_G = 4.7\ \Omega, T_J = 25^\circ\text{C}$		48		ns
Turn-off Delay Time	$t_{d(off)}$			290		
Rise Time	$t_r$			30		
Fall Time	$t_f$			138		mJ
Turn-on Switching Loss	$E_{on}$			1.9		
Turn-off Switching Loss	$E_{off}$			1.8		
Total Switching Loss	$E_{ts}$			3.7		
Turn-on Delay Time	$t_{d(on)}$	$V_{CE} = 600\text{ V}, V_{GE} = 0/15\text{ V}, I_C = 60\text{ A}, R_G = 4.7\ \Omega, T_J = 25^\circ\text{C}$		51		ns
Turn-off Delay Time	$t_{d(off)}$			250		
Rise Time	$t_r$			64		
Fall Time	$t_f$			139		mJ
Turn-on Switching Loss	$E_{on}$			4.5		
Turn-off Switching Loss	$E_{off}$			3.4		
Total Switching Loss	$E_{ts}$			8.0		

# FGHL60T120RWD

## ELECTRICAL CHARACTERISTICS OF IGBT ( $T_J = 25^\circ\text{C}$ unless otherwise noted) (continued)

Parameter	Symbol	Test Conditions	Min	Typ	Max	Unit
<b>SWITCHING CHARACTERISTICS</b>						
Turn-on Delay Time	$t_{d(on)}$	$V_{CE} = 600\text{ V}, V_{GE} = 0/15\text{ V}$ $I_C = 30\text{ A}, R_G = 4.7\ \Omega, T_J = 175^\circ\text{C}$		45		ns
Turn-off Delay Time	$t_{d(off)}$			328		
Rise Time	$t_r$			35		
Fall Time	$t_f$			228		
Turn-on Switching Loss	$E_{on}$			3.3		mJ
Turn-off Switching Loss	$E_{off}$			2.4		
Total Switching Loss	$E_{ts}$			5.7		
Turn-on Delay Time	$t_{d(on)}$		$V_{CE} = 600\text{ V}, V_{GE} = 0/15\text{ V}$ $I_C = 60\text{ A}, R_G = 4.7\ \Omega, T_J = 175^\circ\text{C}$		52	
Turn-off Delay Time	$t_{d(off)}$			296		
Rise Time	$t_r$			68		
Fall Time	$t_f$			224		
Turn-on Switching Loss	$E_{on}$			6.9		mJ
Turn-off Switching Loss	$E_{off}$			5.1		
Total Switching Loss	$E_{ts}$			12.0		

### DIODE CHARACTERISTICS

Forward Voltage	$V_F$	$I_F = 60\text{ A}, T_J = 25^\circ\text{C}$	1.46	1.74	2.08	V
		$I_F = 60\text{ A}, T_J = 175^\circ\text{C}$		1.7		

### DIODE SWITCHING CHARACTERISTICS, INDUCTIVE LOAD

Reverse Recovery Time	$t_{rr}$	$V_R = 600\text{ V}, I_F = 30\text{ A},$ $di_F/dt = 500\text{ A}/\mu\text{s}, T_J = 25^\circ\text{C}$		183		ns
Reverse Recovery Charge	$Q_{rr}$			1815		nC
Reverse Recovery Energy	$E_{REC}$			0.5		mJ
Peak Reverse Recovery Current	$I_{RRM}$			19.9		A
Reverse Recovery Time	$t_{rr}$	$V_R = 600\text{ V}, I_F = 60\text{ A},$ $di_F/dt = 500\text{ A}/\mu\text{s}, T_J = 25^\circ\text{C}$		257		ns
Reverse Recovery Charge	$Q_{rr}$			2651		nC
Reverse Recovery Energy	$E_{REC}$			0.9		mJ
Peak Reverse Recovery Current	$I_{RRM}$			20.6		A
Reverse Recovery Time	$t_{rr}$	$V_R = 600\text{ V}, I_F = 30\text{ A},$ $di_F/dt = 500\text{ A}/\mu\text{s}, T_J = 175^\circ\text{C}$		279		ns
Reverse Recovery Charge	$Q_{rr}$			4008		nC
Reverse Recovery Energy	$E_{REC}$			1.4		mJ
Peak Reverse Recovery Current	$I_{RRM}$			28.7		A
Reverse Recovery Time	$t_{rr}$	$V_R = 600\text{ V}, I_F = 60\text{ A},$ $di_F/dt = 500\text{ A}/\mu\text{s}, T_J = 175^\circ\text{C}$		420		ns
Reverse Recovery Charge	$Q_{rr}$			6392		nC
Reverse Recovery Energy	$E_{REC}$			2.5		mJ
Peak Reverse Recovery Current	$I_{RRM}$			30.3		A

Product parametric performance is indicated in the Electrical Characteristics for the listed test conditions, unless otherwise noted. Product performance may not be indicated by the Electrical Characteristics if operated under different conditions.

# FGHL60T120RWD

## TYPICAL CHARACTERISTICS

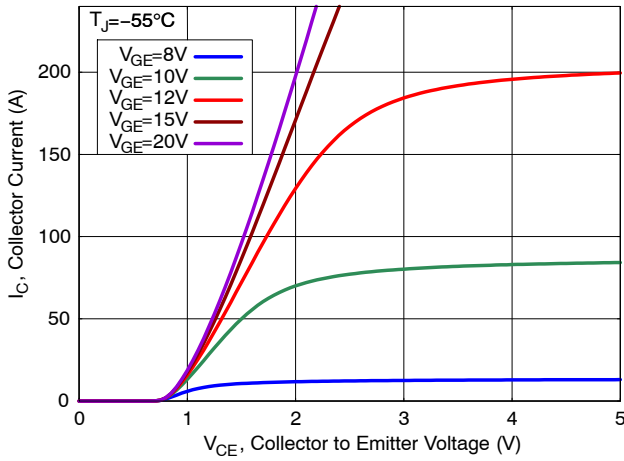

Figure 1. Output Characteristics

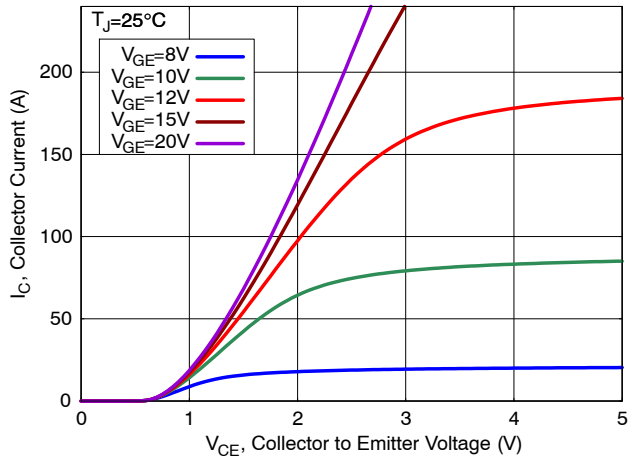

Figure 2. Output Characteristics

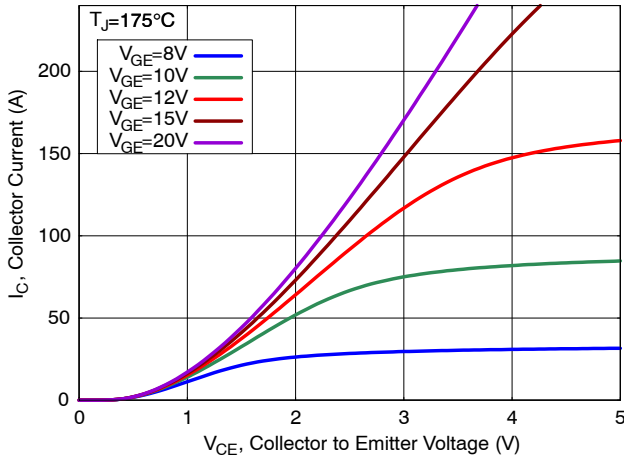

Figure 3. Output Characteristics

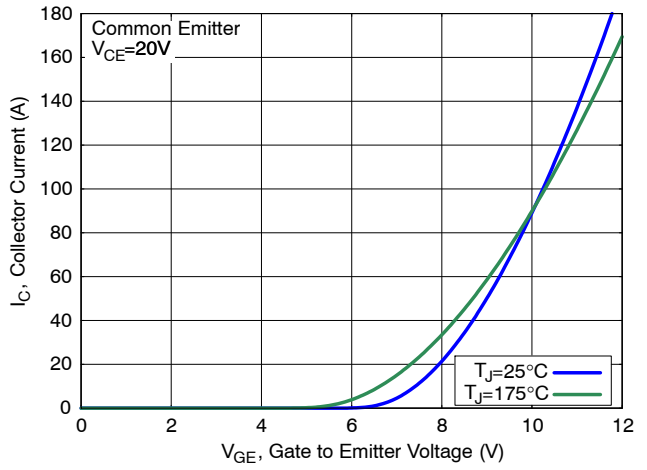

Figure 4. Transfer Characteristics

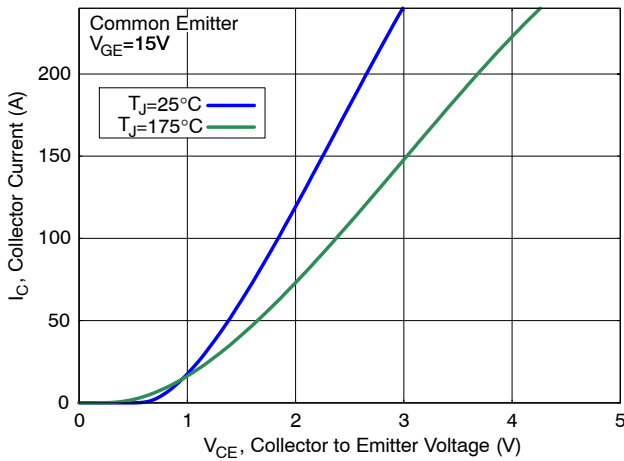

Figure 5. Saturation Characteristics

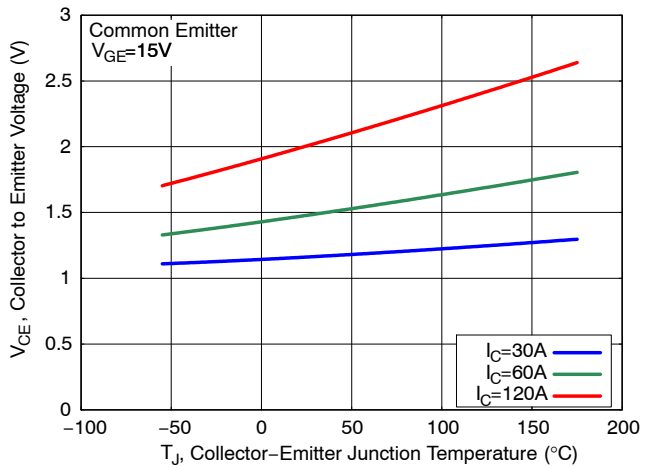

Figure 6. Saturation Voltage vs. Junction Temperature

# FGHL60T120RWD

## TYPICAL CHARACTERISTICS

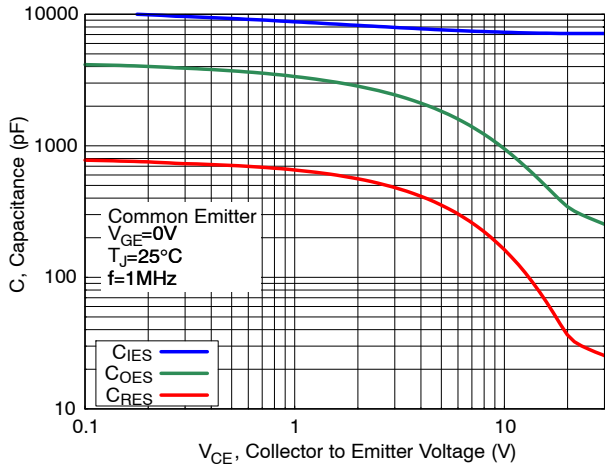

Figure 7. Capacitance Characteristics

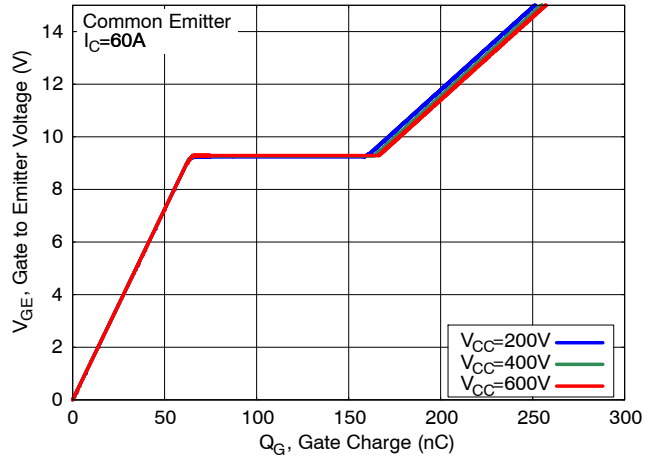

Figure 8. Gate Charge Characteristics

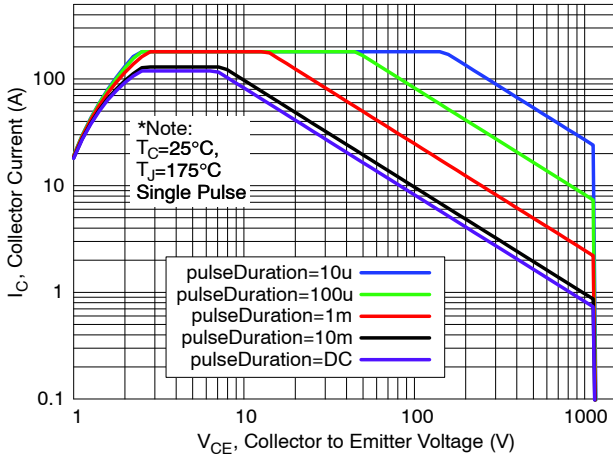

Figure 9. SOA Characteristics

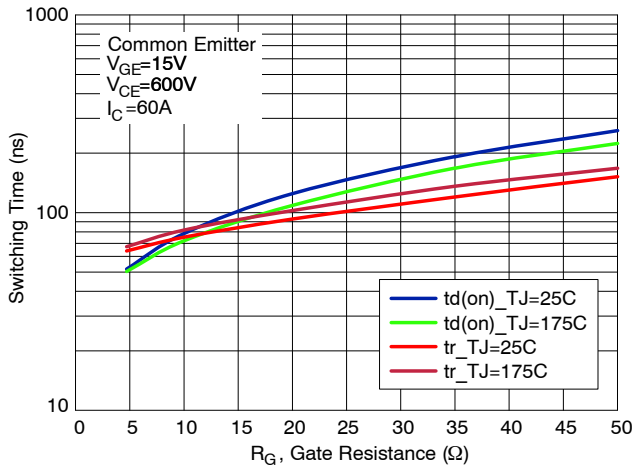

Figure 10. Turn-On Switching Time vs. Gate Resistance

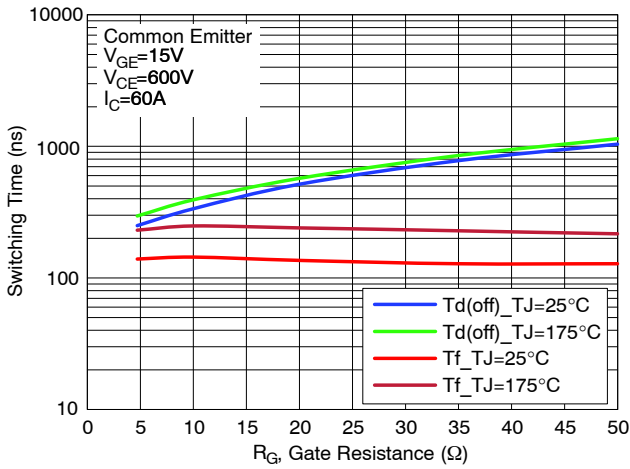

Figure 11. Turn-Off Switching Time vs. Gate Resistance

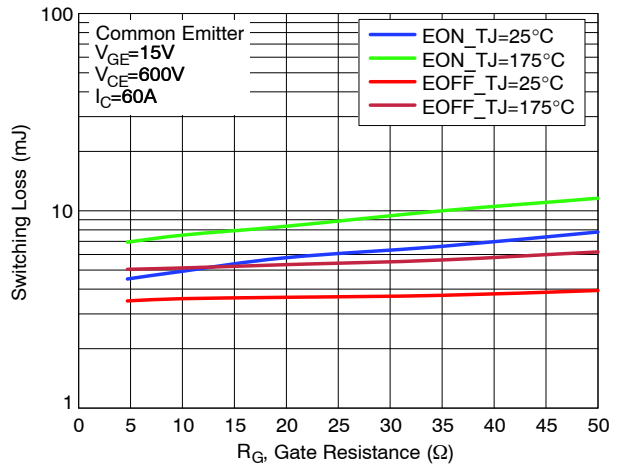
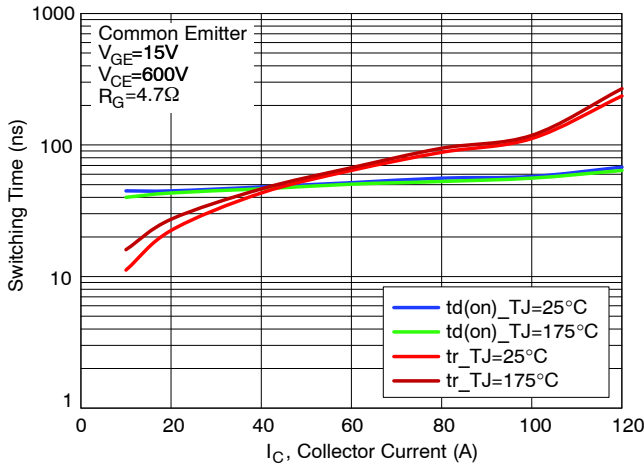

Figure 12. Switching Loss vs. Gate Resistance

# FGHL60T120RWD

## TYPICAL CHARACTERISTICS



**Figure 13. Turn-On Switching Time vs. Collector Current**

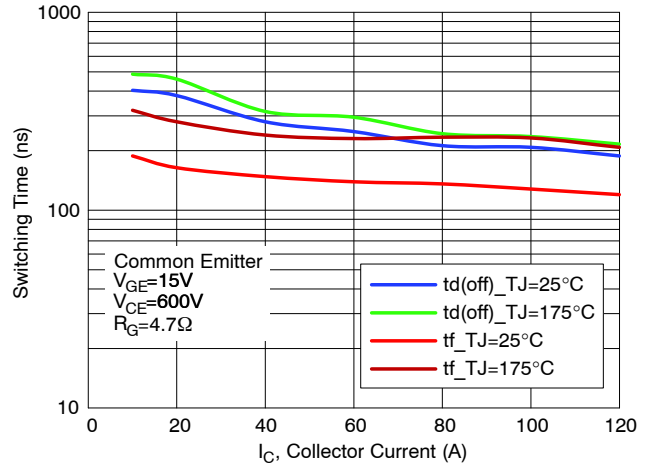

**Figure 14. Turn-Off Switching Time vs. Collector Current**

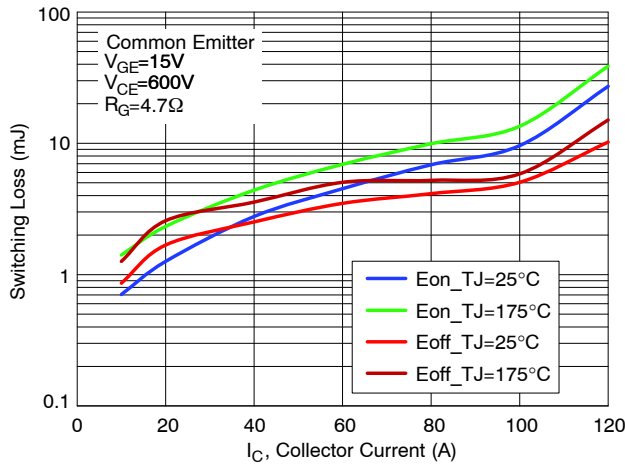

**Figure 15. Switching Loss vs. Collector Current**

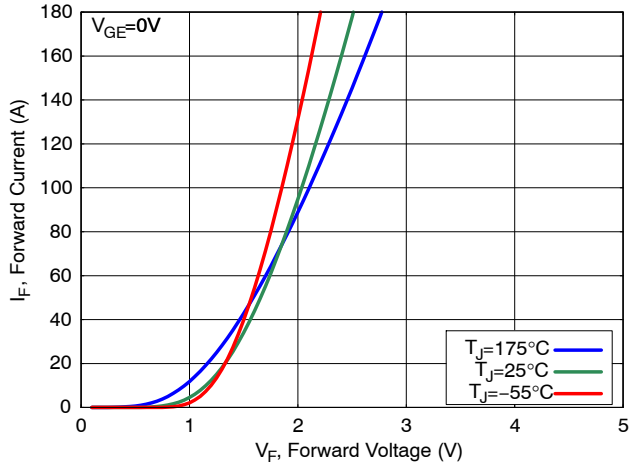

**Figure 16. Diode Forward Characteristics**

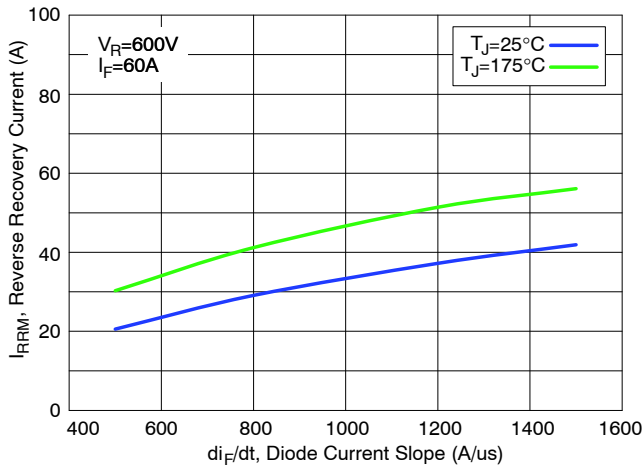

**Figure 17. Diode Reverse Recovery Current**

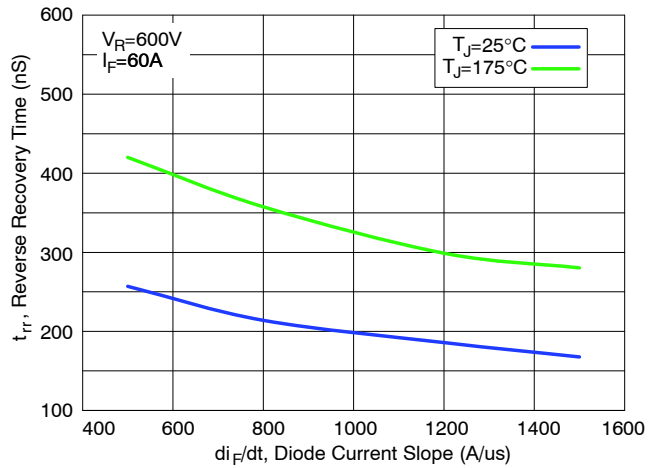

**Figure 18. Diode Reverse Recovery Time**

# FGHL60T120RWD

## TYPICAL CHARACTERISTICS

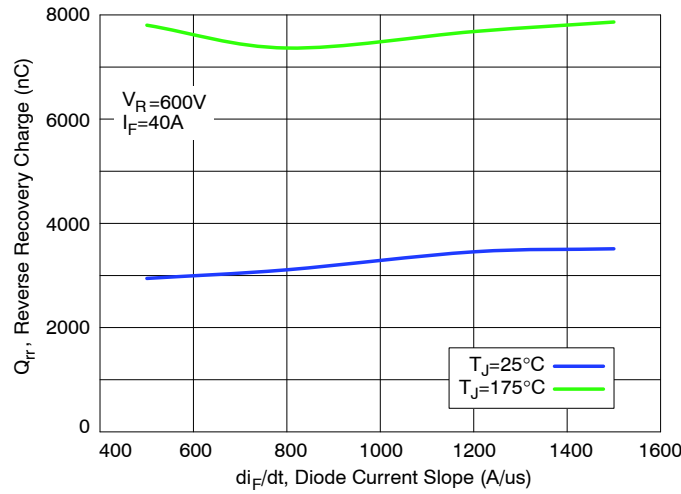

Figure 19. Diode Stored Charge Characteristics

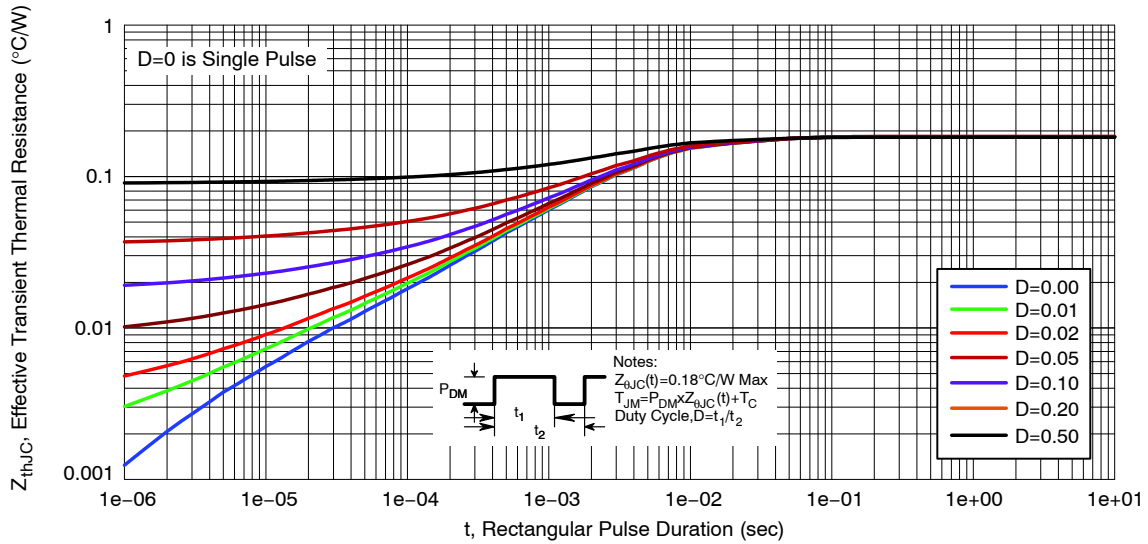

Figure 20. Transient Thermal Impedance of IGBT

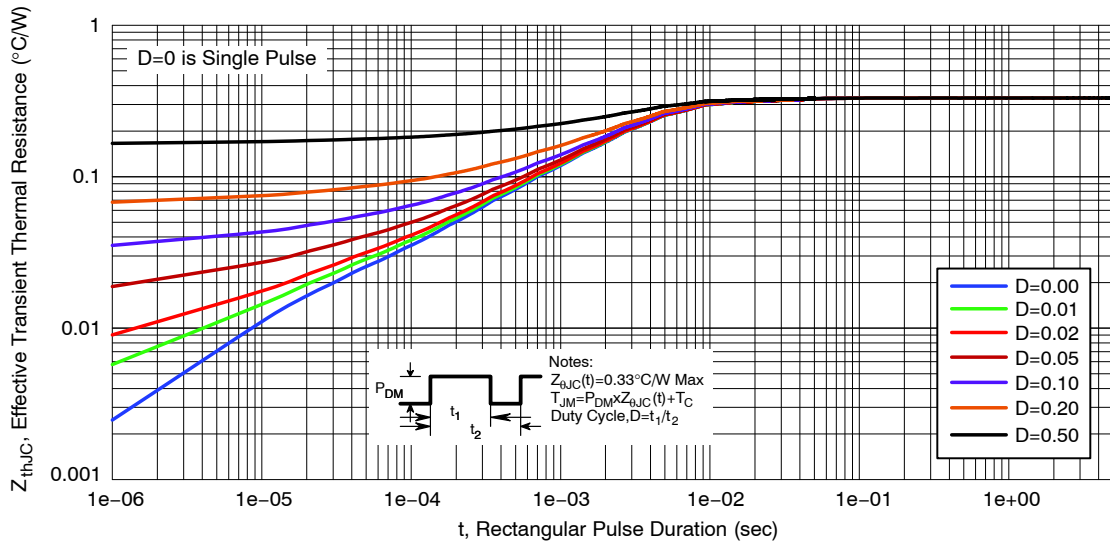
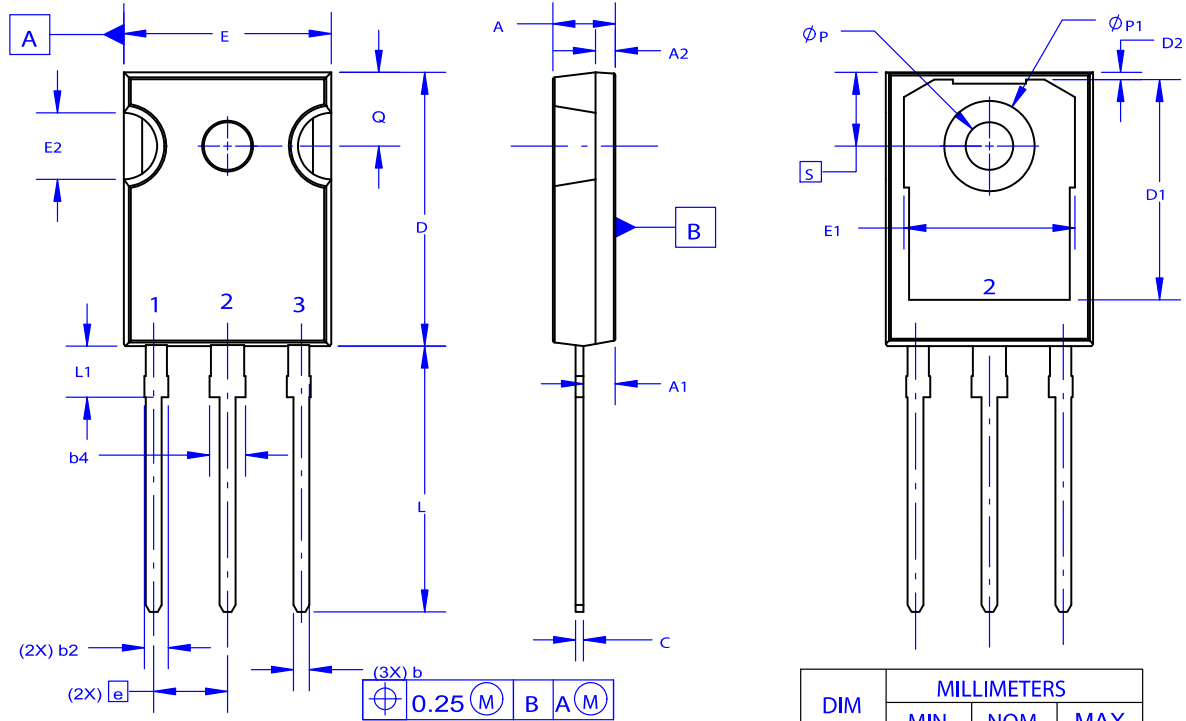

Figure 21. Transient Thermal Impedance of Diode

# FGHL60T120RWD

## PACKAGE DIMENSIONS

TO-247-3LD  
CASE 340CX  
ISSUE A



NOTES: UNLESS OTHERWISE SPECIFIED.

- A. DIMENSIONS ARE EXCLUSIVE OF BURRS, MOLD FLASH, AND TIE BAR EXTRUSIONS.
- B. ALL DIMENSIONS ARE IN MILLIMETERS.
- C. DRAWING CONFORMS TO ASME Y14.5 - 2009.
- D. DIMENSION A1 TO BE MEASURED IN THE REGION DEFINED BY L1.
- E. LEAD FINISH IS UNCONTROLLED IN THE REGION DEFINED BY L1.

DIM	MILLIMETERS		
	MIN	NOM	MAX
A	4.58	4.70	4.82
A1	2.20	2.40	2.60
A2	1.40	1.50	1.60
D	20.32	20.57	20.82
E	15.37	15.62	15.87
E2	4.96	5.08	5.20
e	~	5.56	~
L	19.75	20.00	20.25
L1	3.69	3.81	3.93
phi P	3.51	3.58	3.65
Q	5.34	5.46	5.58
S	5.34	5.46	5.58
b	1.17	1.26	1.35
b2	1.53	1.65	1.77
b4	2.42	2.54	2.66
c	0.51	0.61	0.71
D1	13.08	~	~
D2	0.51	0.93	1.35
E1	12.81	~	~
phi P1	6.60	6.80	7.00

# FGHL60T120RWD

**onsemi**, **Onsemi**, and other names, marks, and brands are registered and/or common law trademarks of Semiconductor Components Industries, LLC dba "**onsemi**" or its affiliates and/or subsidiaries in the United States and/or other countries. **onsemi** owns the rights to a number of patents, trademarks, copyrights, trade secrets, and other intellectual property. A listing of **onsemi**'s product/patent coverage may be accessed at [www.onsemi.com/site/pdf/Patent-Marking.pdf](http://www.onsemi.com/site/pdf/Patent-Marking.pdf). **onsemi** reserves the right to make changes at any time to any products or information herein, without notice. The information herein is provided "as-is" and **onsemi** makes no warranty, representation or guarantee regarding the accuracy of the information, product features, availability, functionality, or suitability of its products for any particular purpose, nor does **onsemi** assume any liability arising out of the application or use of any product or circuit, and specifically disclaims any and all liability, including without limitation special, consequential or incidental damages. Buyer is responsible for its products and applications using **onsemi** products, including compliance with all laws, regulations and safety requirements or standards, regardless of any support or applications information provided by **onsemi**. "Typical" parameters which may be provided in **onsemi** data sheets and/or specifications can and do vary in different applications and actual performance may vary over time. All operating parameters, including "Typicals" must be validated for each customer application by customer's technical experts. **onsemi** does not convey any license under any of its intellectual property rights nor the rights of others. **onsemi** products are not designed, intended, or authorized for use as a critical component in life support systems or any FDA Class 3 medical devices or medical devices with a same or similar classification in a foreign jurisdiction or any devices intended for implantation in the human body. Should Buyer purchase or use **onsemi** products for any such unintended or unauthorized application, Buyer shall indemnify and hold **onsemi** and its officers, employees, subsidiaries, affiliates, and distributors harmless against all claims, costs, damages, and expenses, and reasonable attorney fees arising out of, directly or indirectly, any claim of personal injury or death associated with such unintended or unauthorized use, even if such claim alleges that **onsemi** was negligent regarding the design or manufacture of the part. **onsemi** is an Equal Opportunity/Affirmative Action Employer. This literature is subject to all applicable copyright laws and is not for resale in any manner.

## PUBLICATION ORDERING INFORMATION

### LITERATURE FULFILLMENT:

Email Requests to: [orderlit@onsemi.com](mailto:orderlit@onsemi.com)

**onsemi** Website: [www.onsemi.com](http://www.onsemi.com)

### TECHNICAL SUPPORT

North American Technical Support:

Voice Mail: 1 800-282-9855 Toll Free USA/Canada

Phone: 011 421 33 790 2910

Europe, Middle East and Africa Technical Support:

Phone: 00421 33 790 2910

For additional information, please contact your local Sales Representative