

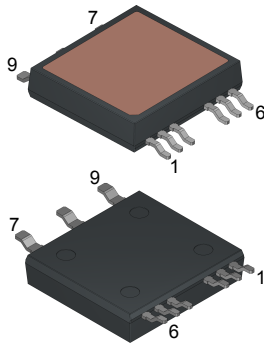

## Automotive-grade ACEPACK SMIT half-bridge topology 650 V, 80 A HB series IGBT with diode

**ACEPACK SMIT**

GADG031120220946SA

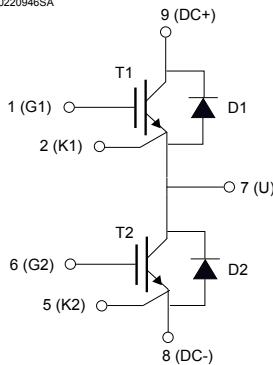

### Features

- AQC 324 qualified 
- High-speed switching series
- Maximum junction temperature:  $T_J = 175\text{ }^\circ\text{C}$
- Low  $V_{CE(sat)} = 1.7\text{ V (typ.) @ } I_C = 80\text{ A}$
- Minimized tail current
- Tight parameter distribution
- Low thermal resistance thanks to DBC substrate
- Positive temperature  $V_{CE(sat)}$  coefficient
- Soft and very fast recovery antiparallel diode
- Isolation rating of 3.4 kVrms/min

### Applications

- DC/DC converter for EV/HEV
- On board charger (OBC)

### Description

This device combines two IGBTs and diodes in half-bridge topology mounted on a very compact and rugged easily surface-mounted package. The device is part of the HB series IGBTs, which is optimized both in conduction and switching losses for soft commutation. A freewheeling diode with a low drop forward voltage is included in every switch. The result is a product specifically designed to maximize efficiency for any resonant and soft-switching applications.

#### Product status link

[STGSH80HB65DAG](#)

#### Product summary

<b>Order code</b>	STGSH80HB65DAG
<b>Marking</b>	GSH80HB65DAG
<b>Package</b>	ACEPACK SMIT
<b>Packing</b>	Tape and reel

# 1 Internal schematic and pin description

**Figure 1. Electrical topology and pin positioning**

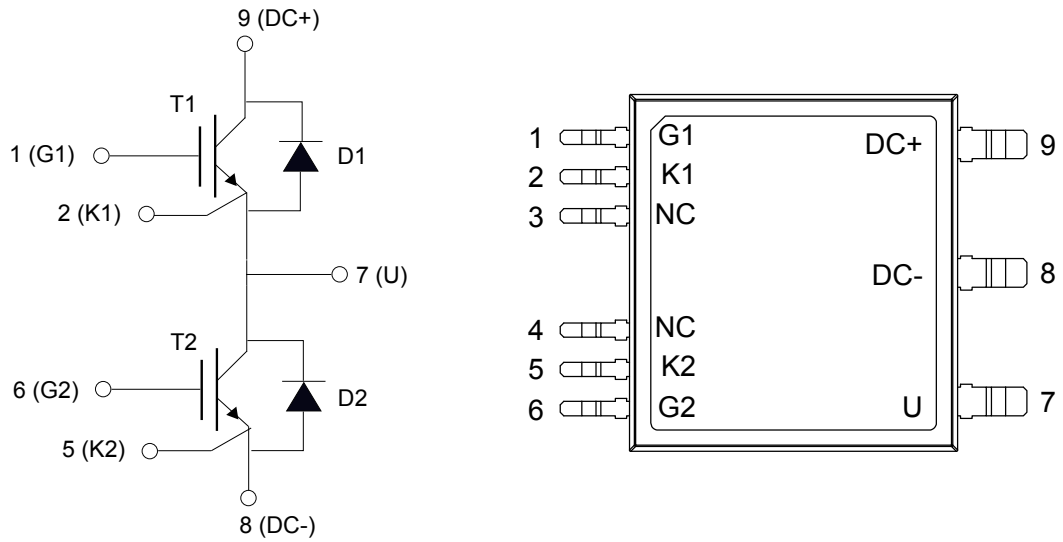

GADG170820230949FF

**Table 1. Pin description**

Pin	Symbol	Description
1	G1	Gate of high-side IGBT
2	K1	Kelvin emitter of high-side IGBT
3	NC	Not connected
4	NC	Not connected
5	K2	Kelvin emitter of low-side IGBT
6	G2	Gate of low-side IGBT
7	U	Phase output
8	DC-	Negative DC input
9	DC+	Positive DC input

## 2 Electrical ratings

Data referred to each IGBT with co-packed diode.

**Table 2. Absolute maximum ratings**

Symbol	Parameter	Value	Unit
$V_{CES}$	Collector-emitter voltage ( $V_{GE} = 0$ V)	650	V
$I_C^{(1)}$	Continuous collector current at $T_C = 25$ °C	83	A
	Continuous collector current at $T_C = 100$ °C	65	
$I_{CP}^{(2)}$	Pulsed collector current ( $t_p = 1$ ms)	269	A
$V_{GE}$	Gate-emitter voltage	±20	V
	Transient gate-emitter voltage ( $t_p \leq 10$ μs)	±30	
$I_F^{(1)}$	Continuous forward current at $T_C = 25$ °C	83	A
	Continuous forward current at $T_C = 100$ °C	65	
$I_{FP}^{(2)}$	Pulsed forward current	187	A
$P_{TOT}$	Total power dissipation at $T_C = 25$ °C	250	W

1. Current limited by package.
2. Pulse width is limited by maximum junction temperature.

**Table 3. Thermal data**

Symbol	Parameter	Value	Unit
$R_{thJC}$	Thermal resistance, junction-to-case IGBT	0.6	°C/W
	Thermal resistance, junction-to-case diode	0.8	

**Table 4. Total system**

Symbol	Parameter	Value	Unit
$V_{ISO}$	Isolation withstand voltage applied between each pin and heat sink plate (AC voltage 50/60 Hz, $t = 60$ s)	3.4	kVrms
$T_{STG}$	Storage temperature range	-55 to 150	°C
$T_J$	Operating junction temperature range	-55 to 175	°C

### 3 Electrical characteristics

$T_J = 25\text{ °C}$  unless otherwise specified.

**Table 5. Static characteristics**

Symbol	Parameter	Test conditions	Min.	Typ.	Max.	Unit
$V_{(BR)CES}$	Collector-emitter breakdown voltage	$V_{GE} = 0\text{ V}, I_C = 1\text{ mA}$	650			V
$V_{CE(sat)}$	Collector-emitter saturation voltage	$V_{GE} = 15\text{ V}, I_C = 80\text{ A}$		1.7	2.1	V
		$V_{GE} = 15\text{ V}, I_C = 80\text{ A}, T_J = 125\text{ °C}$		1.85		
		$V_{GE} = 15\text{ V}, I_C = 80\text{ A}, T_J = 175\text{ °C}$		2.0		
$V_F$	Forward on-voltage	$I_F = 80\text{ A}$		1.9		V
		$I_F = 80\text{ A}, T_J = 125\text{ °C}$		1.5		
		$I_F = 80\text{ A}, T_J = 175\text{ °C}$		1.4		
$V_{GE(th)}$	Gate threshold voltage	$V_{CE} = V_{GE}, I_C = 1\text{ mA}$	4.5	5.5	6.5	V
$I_{CES}$	Collector cut-off current	$V_{GE} = 0\text{ V}, V_{CE} = 650\text{ V}$			10	$\mu\text{A}$
$I_{GES}$	Gate-emitter leakage current	$V_{CE} = 0\text{ V}, V_{GE} = \pm 20\text{ V}$			800	nA

**Table 6. Dynamic characteristics**

Symbol	Parameter	Test conditions	Min.	Typ.	Max.	Unit
$C_{ies}$	Input capacitance	$V_{CE} = 25\text{ V}, f = 1\text{ MHz}, V_{GE} = 0\text{ V}$	-	10450	-	pF
$C_{oes}$	Output capacitance		-	377	-	pF
$C_{res}$	Reverse transfer capacitance		-	206	-	pF
$Q_g$	Total gate charge	$V_{CC} = 520\text{ V}, I_C = 80\text{ A}, V_{GE} = 15\text{ V}$	-	456	-	nC

**Table 7. Switching characteristics (inductive load)**

Symbol	Parameter	Test conditions	Min.	Typ.	Max.	Unit
$t_{d(on)}$	Turn-on delay time	$V_{CC} = 400\text{ V}$ , $V_{GK} = 0\text{ to }15\text{ V}$ , $R_G = 8.2\ \Omega$ , $I_C = 80\text{ A}$	-	65	-	ns
$t_r$	Current rise time		-	20	-	ns
$E_{on}^{(1)}$	Turn-on switching energy		-	0.95	-	mJ
$t_{d(off)}$	Turn-off delay time		-	284	-	ns
$t_f$	Current fall time		-	18	-	ns
$E_{off}^{(2)}$	Turn-off switching energy		-	1.3	-	mJ
$t_{d(on)}$	Turn-on delay time	$V_{CC} = 400\text{ V}$ , $V_{GK} = 0\text{ to }15\text{ V}$ , $R_G = 8.2\ \Omega$ , $I_C = 80\text{ A}$ , $T_J = 175^\circ\text{C}$	-	64	-	ns
$t_r$	Current rise time		-	18	-	ns
$E_{on}^{(1)}$	Turn-on switching energy		-	2	-	mJ
$t_{d(off)}$	Turn-off delay time		-	281	-	ns
$t_f$	Current fall time		-	14	-	ns
$E_{off}^{(2)}$	Turn-off switching energy		-	2.2	-	mJ

1. Including the reverse recovery of the diode
2. Including the tail of the collector current

**Table 8. Diode switching characteristics (inductive load)**

Symbol	Parameter	Test conditions	Min.	Typ.	Max.	Unit
$t_{rr}$	Reverse recovery time	$I_F = 80\text{ A}$ , $V_R = 400\text{ V}$ , $V_{GK} = 15\text{ V}$ , $R_G = 8.2\ \Omega$	-	26	-	ns
$Q_{rr}$	Reverse recovery charge		-	1.2	-	$\mu\text{C}$
$I_{rrm}$	Reverse recovery current		-	90	-	A
$E_{rr}$	Reverse recovery energy		-	0.17	-	mJ
$t_{rr}$	Reverse recovery time	$I_F = 80\text{ A}$ , $V_R = 400\text{ V}$ , $V_{GK} = 15\text{ V}$ , $R_G = 8.2\ \Omega$ , $T_J = 175^\circ\text{C}$	-	59	-	ns
$Q_{rr}$	Reverse recovery charge		-	6.1	-	$\mu\text{C}$
$I_{rrm}$	Reverse recovery current		-	143	-	A
$E_{rr}$	Reverse recovery energy		-	1.3	-	mJ

### 3.1 Electrical characteristics (curves)

**Figure 2. Typical output characteristics ( $T_J = 25\text{ }^\circ\text{C}$ )**

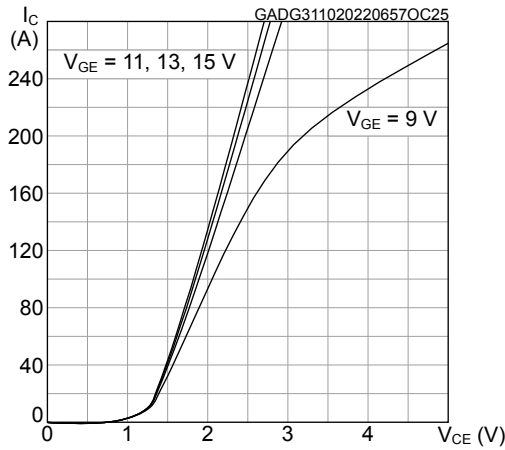

**Figure 3. Typical output characteristics ( $T_J = 175\text{ }^\circ\text{C}$ )**

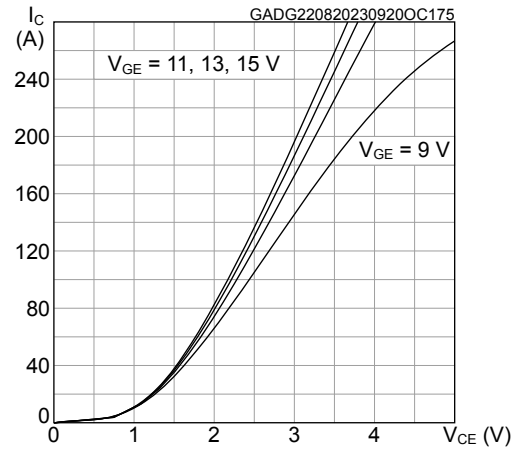

**Figure 4. Normalized  $V_{CE(sat)}$  vs temperature**

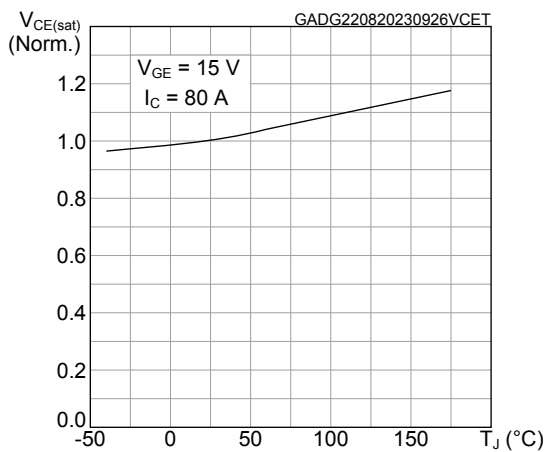

**Figure 5. Typical  $V_{CE(sat)}$  vs collector current**

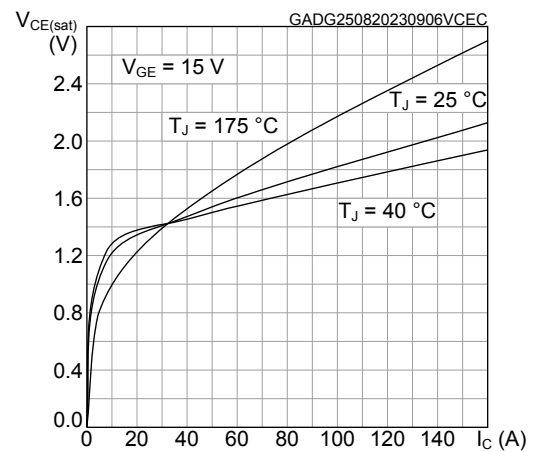

**Figure 6. Typical transfer characteristics**

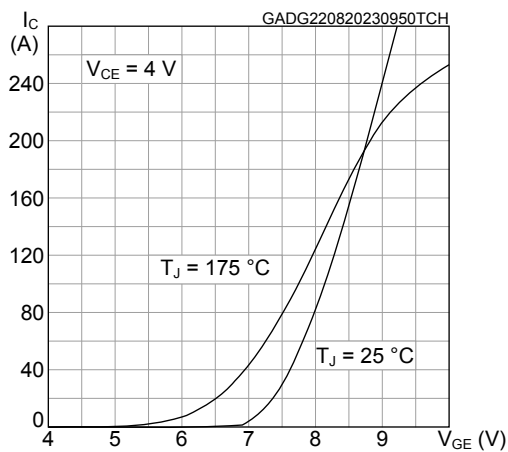

**Figure 7. Typical diode  $V_F$  vs forward current**

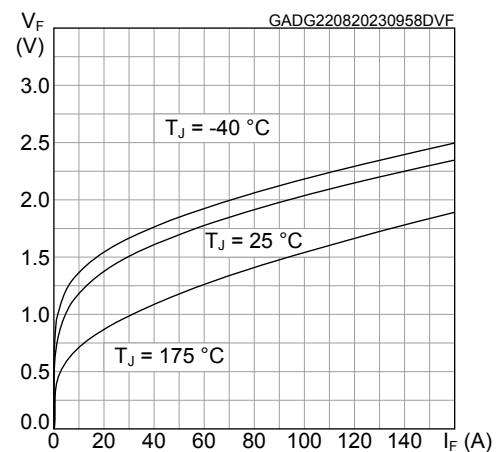

**Figure 8. Normalized  $V_{GE(th)}$  vs temperature**

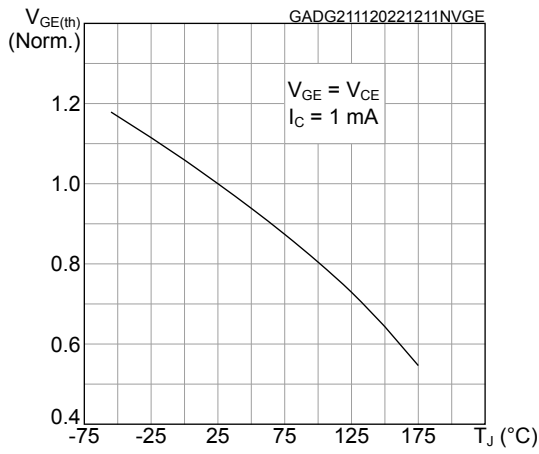

**Figure 9. Normalized  $V_{(BR)CES}$  vs temperature**

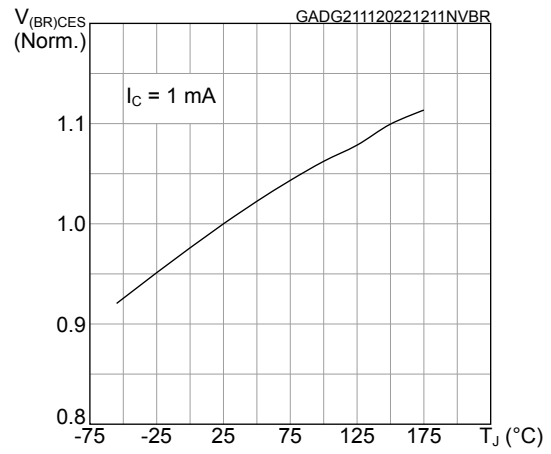

**Figure 10. Typical capacitance characteristics**

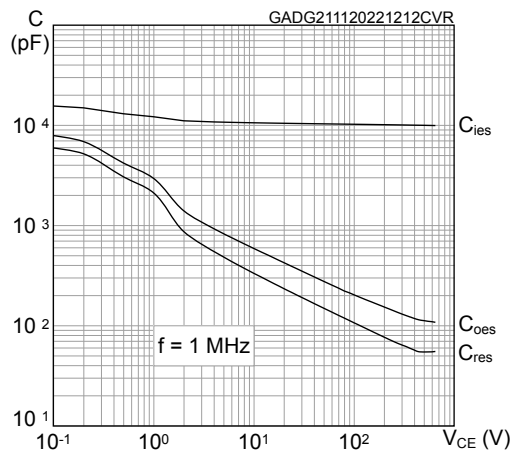

**Figure 11. Typical gate charge characteristics**

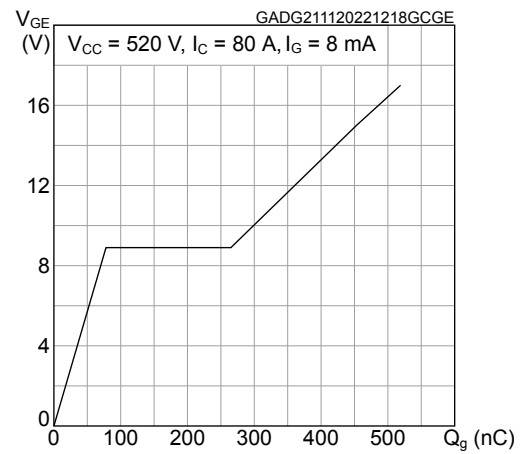

**Figure 12. Typical switching energy vs collector current**

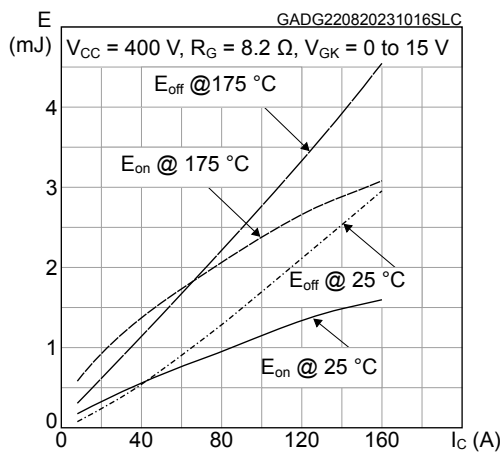

**Figure 13. Typical switching energy vs supply voltage**

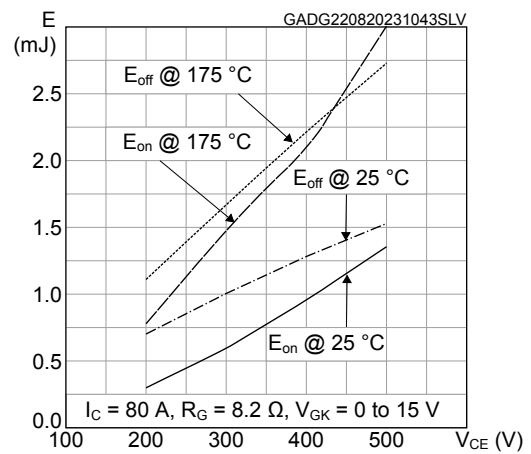

**Figure 14. Typical switching energy vs temperature**

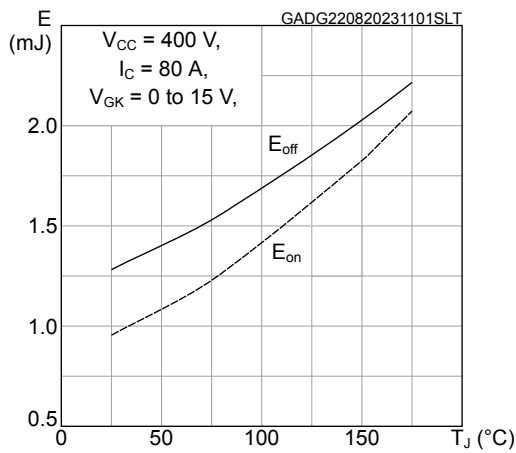

**Figure 15. Typical switching energy vs  $R_G$**

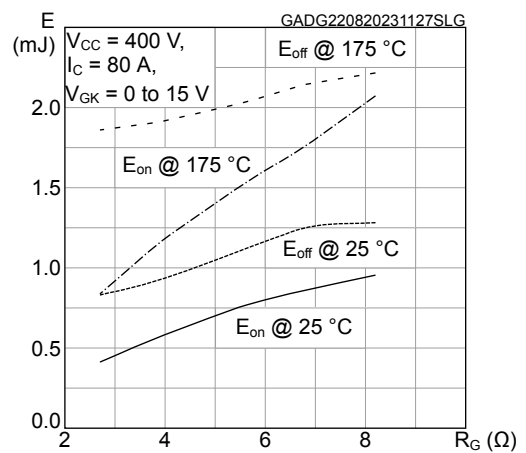

**Figure 16. Diode reverse recovery time vs forward current**

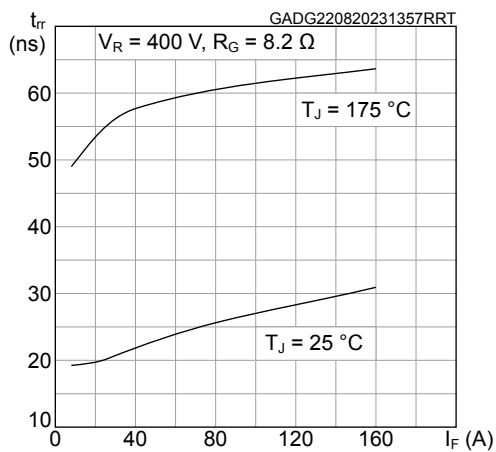

**Figure 17. Diode reverse recovery current vs forward current**

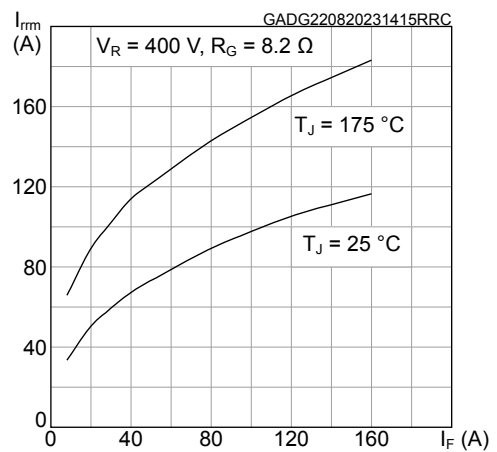

**Figure 18. Diode reverse recovery charge vs forward current**

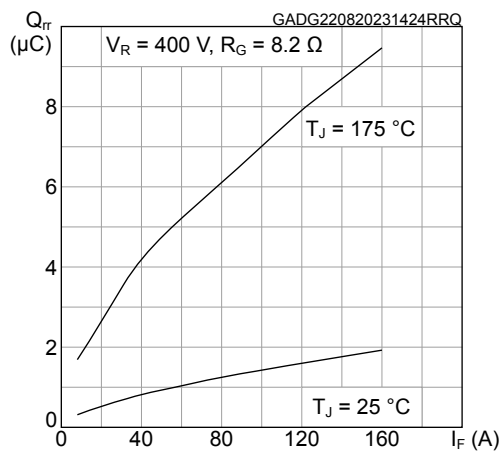

**Figure 19. Diode reverse recovery energy vs forward current**

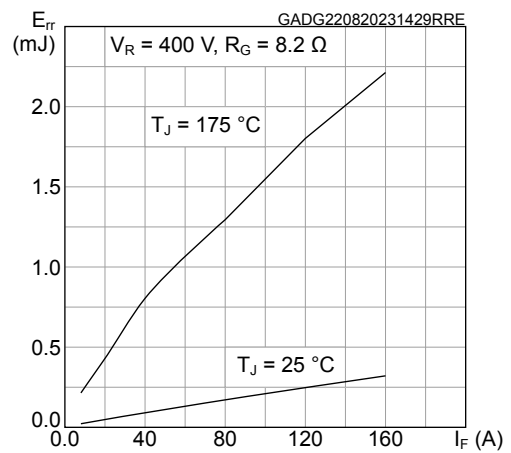

**Figure 20. Maximum transient thermal impedance for IGBT**

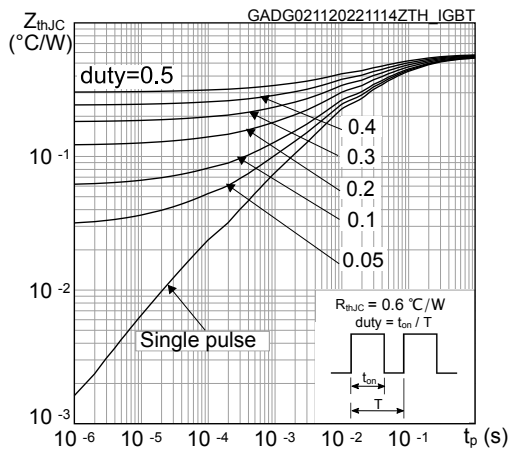

**Figure 21. Maximum transient thermal impedance for diode**

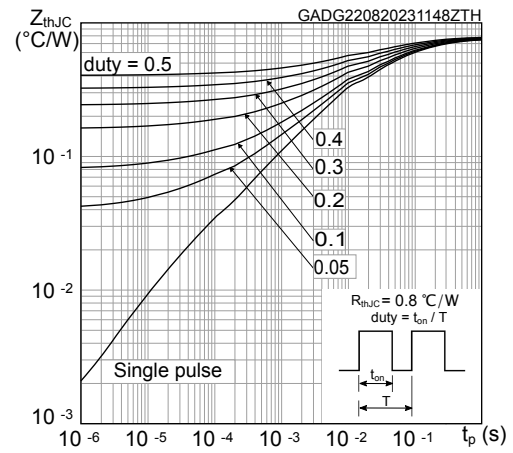

**Figure 22. Forward bias safe operating area**

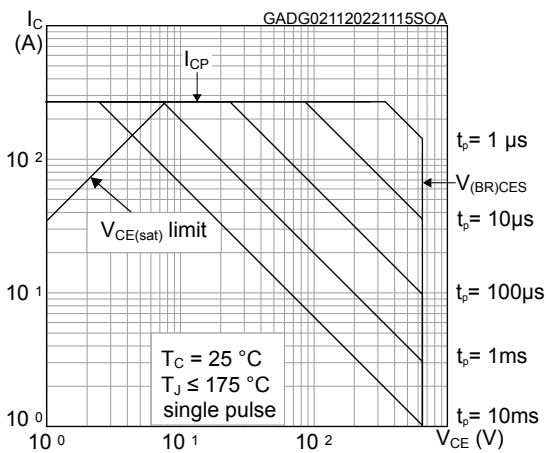

## 4 Test circuits

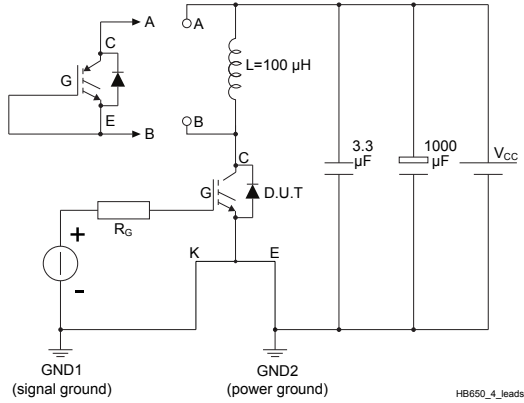
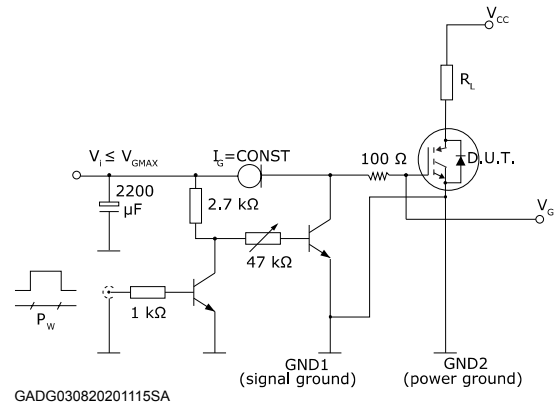
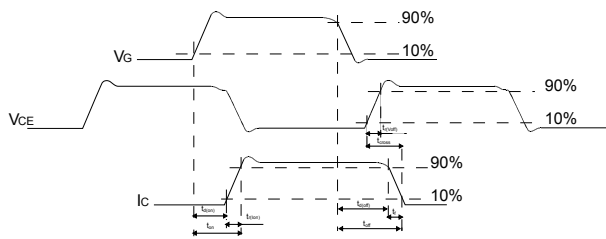
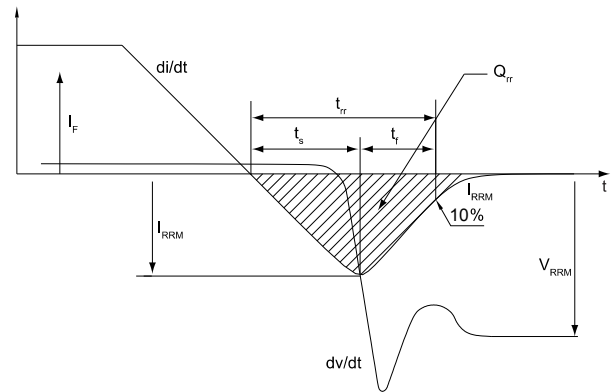
**Figure 23. Test circuit for inductive load switching**

**Figure 24. Gate charge test circuit**

**Figure 25. Switching waveform**

**Figure 26. Diode reverse recovery waveform**

## 5 Package information

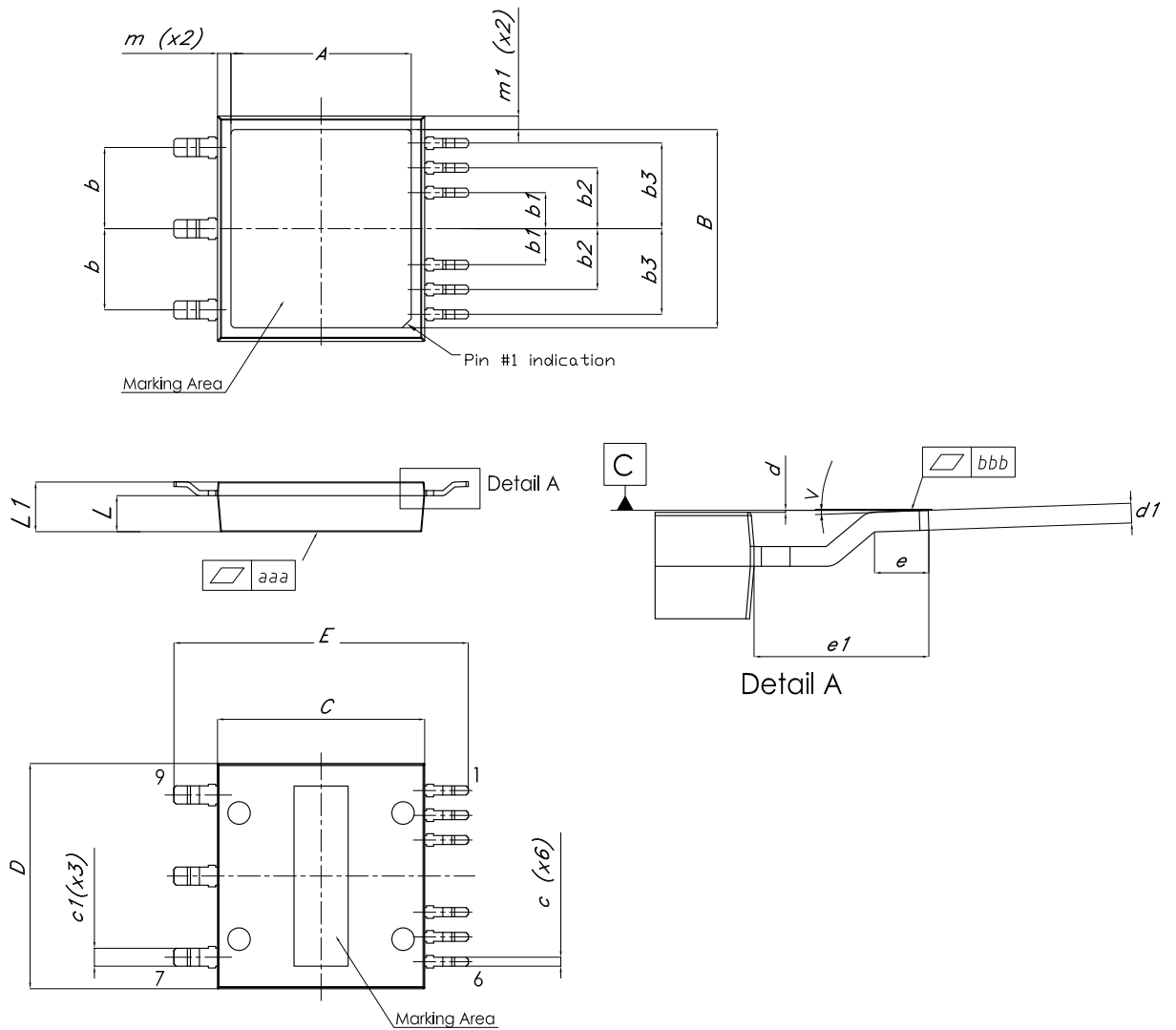
In order to meet environmental requirements, ST offers these devices in different grades of **ECOPACK** packages, depending on their level of environmental compliance. ECOPACK specifications, grade definitions and product status are available at: [www.st.com](http://www.st.com). ECOPACK is an ST trademark.

### 5.1 ACEPACK SMIT package information

Figure 27. ACEPACK SMIT package outline



DM00447519\_Rev.6

**Table 9. ACEPACK SMIT package mechanical data**

Dim.	mm		
	Min.	Typ.	Max.
A	19.50	20.00	20.50
B	21.50	22.00	22.50
C	22.80	23.00	23.20
D	24.80	25.00	25.20
E	32.20	32.70	33.20
b		9.00	
b1		4.00	
b2		6.75	
b3		9.50	
c	0.95	1.00	1.10
c1	1.95	2.00	2.10
d	0.00		0.15
d1	0.45	0.55	0.65
e	1.30	1.50	1.70
e1	4.65	4.85	5.05
L	3.95	4.00	4.05
L1	5.40	5.50	5.60
m	1.30	1.50	1.80
m1	1.30	1.50	1.80
V	0°	2°	4°
aaa	0.01		0.05
bbb	0.00		0.10

**Figure 28. ACEPACK SMIT recommended footprint**

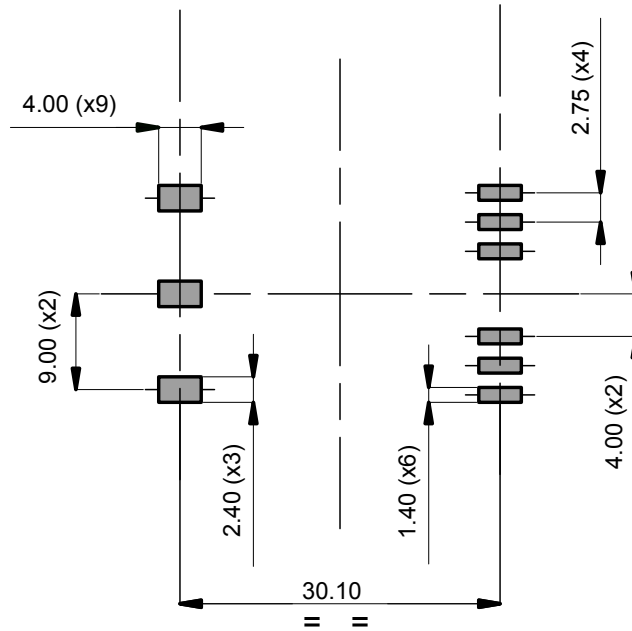

DM00447519\_FP\_Rev.6

Note: Dimensions in mm.

**Figure 29. ACEPACK SMIT marking orientation vs pinout**

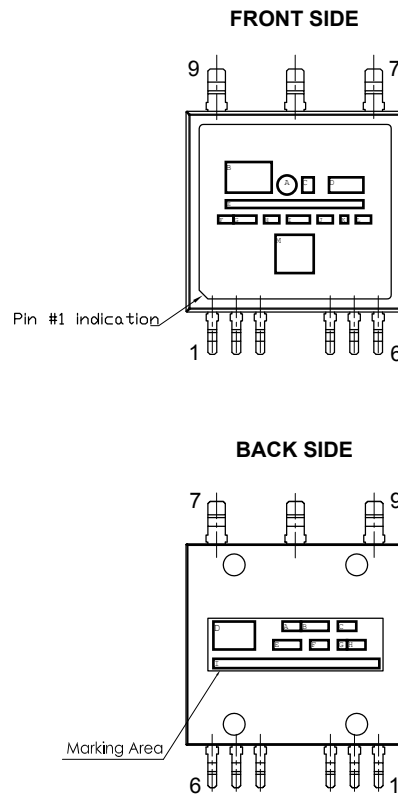

DM00447519\_MO\_Rev.6

## 5.2 ACEPACK SMIT packing information

Figure 30. ACEPACK SMIT tape outline

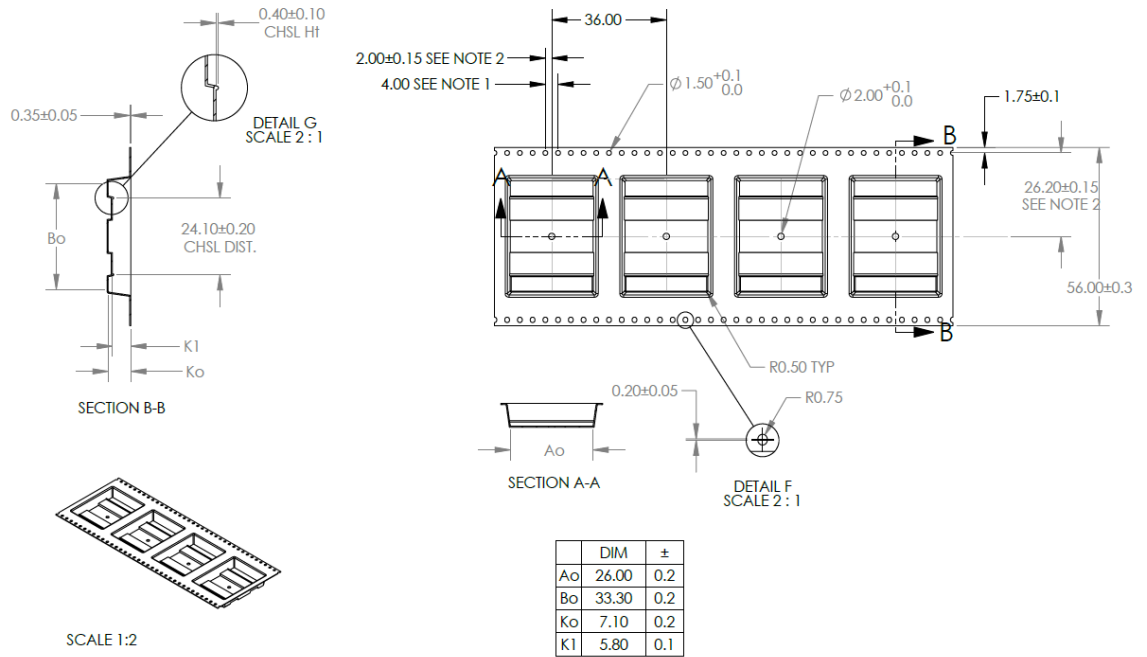

NOTES:

1. TO SPROCKET HOLE PITCH CUMULATIVE TOLERANCE  $\pm 0.2$
2. POCKET POSITION RELATIVE TO SPROCKET HOLE MEASURED AS TRUE POSITION OF POCKET, NOT POCKET HOLE.
3.  $A_o$  AND  $B_o$  ARE MEASURED ON A PLANE AT A DISTANCE "R" ABOVE THE BOTTOM OF THE POCKET.

DM00631393\_Tape\_Rev.1

Note: Dimensions in mm.

## Revision history

**Table 10. Document revision history**

Date	Revision	Changes
14-Nov-2022	1	First release.
28-Aug-2023	2	<p>Updated <a href="#">Features</a> on cover page.</p> <p>Added <a href="#">Table 4. Total system</a>.</p> <p>Added <a href="#">Section 1 Internal schematic and pin description</a> and removed <i>"Topology, pin description and positioning"</i>.</p> <p>Added <a href="#">Section 4 Test circuits</a>.</p> <p>Updated <a href="#">Table 5. Static characteristics</a>, <a href="#">Table 7. Switching characteristics (inductive load)</a> and <a href="#">Table 8. Diode switching characteristics (inductive load)</a>.</p> <p>Updated <a href="#">Section 3.1 Electrical characteristics (curves)</a>.</p>

---

## Contents

<b>1</b>	<b>Internal schematic and pin description</b> .....	<b>2</b>
<b>2</b>	<b>Electrical ratings</b> .....	<b>3</b>
<b>3</b>	<b>Electrical characteristics</b> .....	<b>4</b>
<b>3.1</b>	<b>Electrical characteristics (curves)</b> .....	<b>6</b>
<b>4</b>	<b>Test circuits</b> .....	<b>10</b>
<b>5</b>	<b>Package information</b> .....	<b>11</b>
<b>5.1</b>	<b>ACEPACK SMIT package information</b> .....	<b>11</b>
<b>5.2</b>	<b>ACEPACK SMIT packing information</b> .....	<b>14</b>
	<b>Revision history</b> .....	<b>15</b>

**IMPORTANT NOTICE – READ CAREFULLY**

STMicroelectronics NV and its subsidiaries (“ST”) reserve the right to make changes, corrections, enhancements, modifications, and improvements to ST products and/or to this document at any time without notice. Purchasers should obtain the latest relevant information on ST products before placing orders. ST products are sold pursuant to ST’s terms and conditions of sale in place at the time of order acknowledgment.

Purchasers are solely responsible for the choice, selection, and use of ST products and ST assumes no liability for application assistance or the design of purchasers’ products.

No license, express or implied, to any intellectual property right is granted by ST herein.

Resale of ST products with provisions different from the information set forth herein shall void any warranty granted by ST for such product.

ST and the ST logo are trademarks of ST. For additional information about ST trademarks, refer to [www.st.com/trademarks](http://www.st.com/trademarks). All other product or service names are the property of their respective owners.

Information in this document supersedes and replaces information previously supplied in any prior versions of this document.

© 2023 STMicroelectronics – All rights reserved