

RP40 lite

5G, 4G/LTE 4x4 MIMO Fixed Wireless Access Omnidirectional Antenna

The RP40 lite (L000306-XX) antenna family from TE Connectivity (TE) provides high-performance connectivity for current and emerging 4G and 5G frequencies in a flexible and modular package.

The incorporated 4x4 MIMO technology and consistent radiation patterns means that the RP40 lite can provide enhanced data rates and bandwidth with extremely consistent performance.

RP40 lite is suitable for use globally on cellular networks and with any network operator. It fits most common industrial routers/gateways currently on the market. There are 4 or 5-port variants available with the optional fifth port for GNSS coverage. Each model covers 617 - 6000 MHz and supports all major global 5G and 4G/LTE bands.

Designed with a stylish housing and includes all the necessary mounting hardware for desk, wall, offset wall and pole mounting options.

FEATURES AND BENEFITS

- Global LTE and 5G coverage (617-6000MHz)
- Consistent omnidirectional patterns across all bands, providing stable reception
- Extensive mechanical and environmental testing including UV, flammability, humidity, impact, vibration, shock (see page 3 for full details)
- Integrated 5m (16ft) cables for easier installation
- Supplied with all brackets and mounting hardware

APPLICATIONS

- Primary connectivity
- Fixed Wireless Access (FWA)
- Failover support
- IoT device connections
- Private networks

APPLICATIONS

Remote Offices



Hotel Rooms



Construction Sites

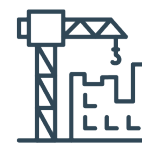

Remote Schools



Rural Communities



Temporary Usage



SPECIFICATIONS

ELECTRICAL SPECIFICATION						
Operating Frequency (MHz)	617-698	698-960	1427-1496	1559-1606	1690-4200	4200-6000
VSWR - Max	<2.20		<2.20			
Isolation - Min (dB)*	10					
Peak Gain - Max (dBi)*	5.2		6.5			
Total Efficiency Average (%)	77					
Nominal Impedance (Ohms)	50					
Max Power - Ambient 25°C (W)	10					
Polarization	Linear Dual Polarized (2V x 2H)					
Azimuth Beamwidth	360°, Omnidirectional					

*Measured with 1.5ft LMR195 equivalent coaxial cable

ELECTRICAL SPECIFICATION - GNSS			
Operating Frequency (MHz)	1561.098 ± 2.046	1575.42 ± 1.023	1602 ± 5
VSWR - Max	<2.0		
LNA Gain, dB	28 ± 3		
LNA Noise Figure, dB	3.17	2.87	3.06
LNA Input Max. Power, dBm	-10		
Out of band Rejection (dBc)	698-960MHz	>80	
	1428-1511MHz	>80	
	1710-2700MHz	>80	
	4900-5800MHz	>70	
DC Voltage, V	2.5-7.0		
Current, mA	8.5 ± 3 (at 3.0V)		
Nominal Impedance	50		
Polarization	RHCP		

MECHANICAL SPECIFICATION	
Dimensions - Length x Width x Height - mm (in.)	380 x 230 x 30 mm (14.96 x 9.05 x 1.18)
Weight kg (lbs.)	L000306-01 - 1.3 (2.87) L000306-02 - 1.5 (3.31)
Cable	Cellular: LMR 195-equivalent GNSS: RG174
Radome Color / Material	White FRPC2100 UV
Base Material	PC-ABS FR-V0, UV
Mounting	Multiple Options Supplied

ENVIRONMENTAL SPECIFICATION

Operating Temp. (°C)	-40 to +85
Storage Temperature (°C)	-40 to +85
Temperature Cycling	IEC 68-2-14
Ingress Protection (IP Rating)	IP66
Humidity	MIL-STD-810G, 507.5, Procedure II, Aggravated Humidity
Thermal Shock	IEC 68-2-14: -25°C to +70°C
Corrosive Atmosphere (Salt Fog/Mist)	MIL-STD-810G, Method 509.5
Vibration	IEC 60068-2-64
Mechanical Shock	IEC 60068-2-27
Wind Operational	Simulated 100MPH
Wind Survival	Simulated 136MPH
Pull Test	20lb Pull on Connector/Cables: Duration of 30 Seconds
UV Resistance	ASTM-G-155
Flammability Rating	UL94-V0
Material Substance Compliance	RoHS Compliant, CE & UKCA Compliant California Prop 65 Compliant, European RED Compliant

PART NUMBER CONFIGURATIONS

PART NUMBER	PIGTAIL/CABLE	CONNECTOR	NUMBER PORTS	FREQUENCY
L000306-01	Integrated Cable - 5m (16ft.)	4 x SMA Male	4	Cellular: 617-6000 MHz
L000306-02	Integrated Cable - 5m (16ft.)	5 x SMA Male	5	Cellular: 617-6000 MHz GNSS: 1561 - 1602 MHz

MOUNTING OPTIONS (MOUNTING KITS INCLUDED)

Desk Mount

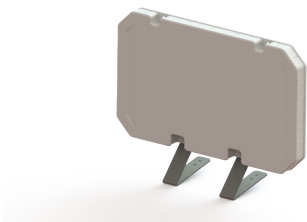

Direct Wall Mount



Pole Mount



Offset Wall Mount



MECHANICAL DRAWINGS

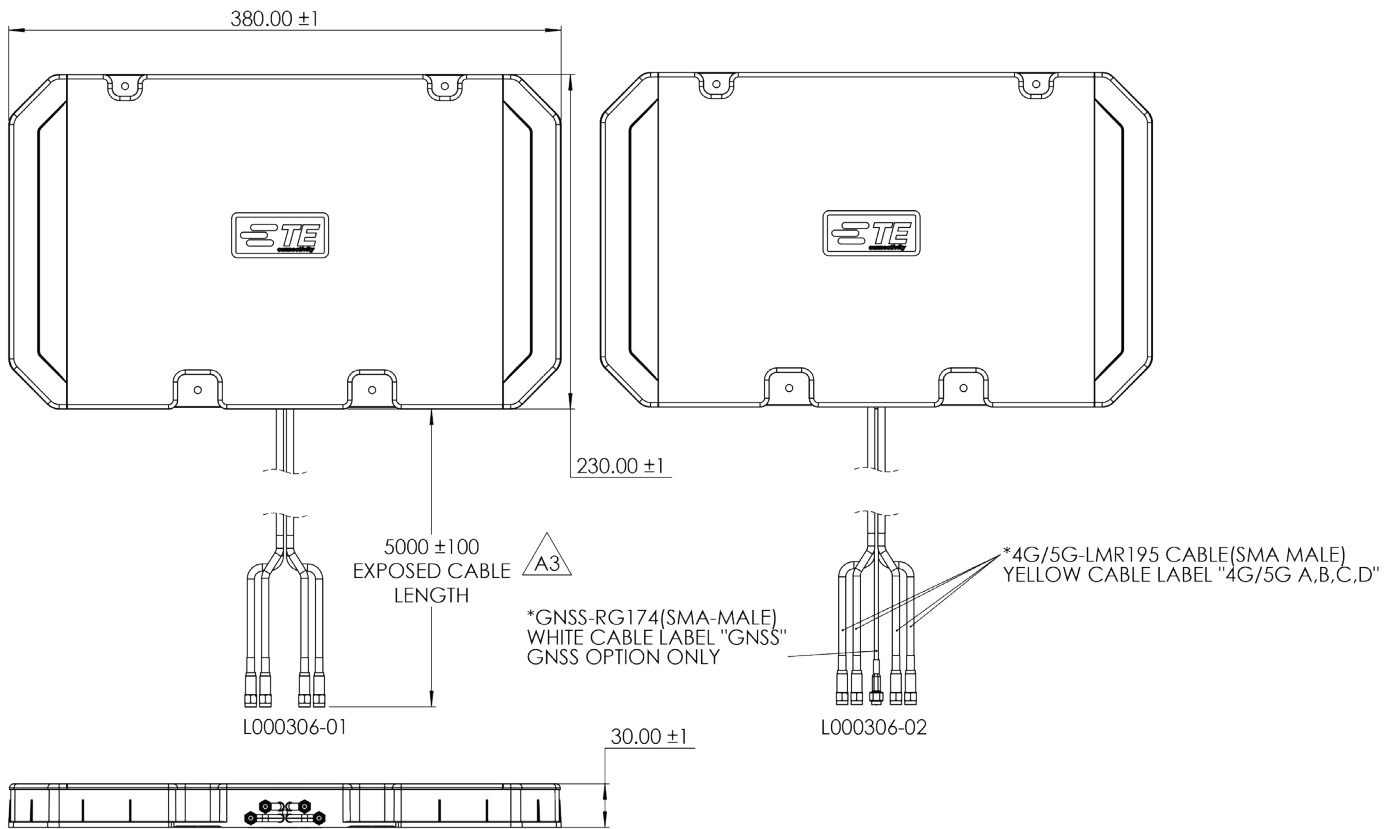

MOUNTING OPTION DRAWINGS

Desk Mount

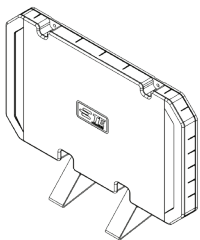

Direct Wall Mount

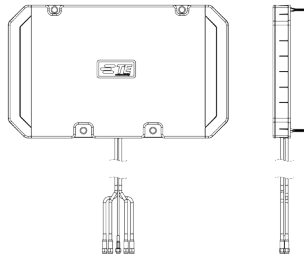

Offset Wall Mount

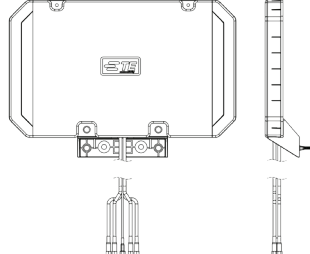

Pole Mount

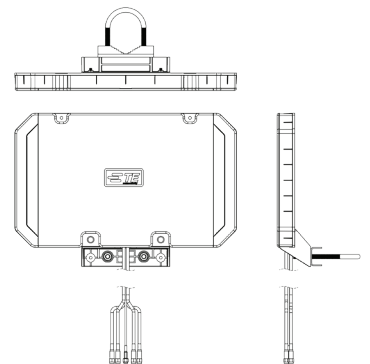

GLOBAL 4G/5G CELLULAR COVERAGE

The **RP40 lite** antenna provides global sub-6 GHz cellular coverage. The table below shows the frequencies and bands covered and the corresponding performance across those bands is shown in the charts below.

FREQUENCY	RF BANDS COVERED
617-960 MHz	5, 6, 8, 12, 13, 14, 17, 18, 19, 20, 26, 27, 28, 29, 44, 67, 68, 71, 85 N5, N8, N12, N14, N18, N20, N28, N29, N71, N81, N82, N83, N89, N91, N92, N93, N94, N100
1427-1690 MHz	11, 21, 24, 32, 45, 74, 75, 76 N50, N51, N74, N75, N76
1690-2700 MHz	1, 2, 3, 4, 7, 9, 10, 15, 16, 23, 25, 30, 33, 34, 35, 36, 37, 38, 39, 40, 41, 65, 66, 69, 70 N30, N34, N38, N39, N40, N41, N65, N66, N70, N80, N84, N86, N90, N95, N101
3300-6000 MHz	22, 42, 43, 46, 47, 48 N48, N77, N78, N79

LTE - VSWR

L000306-01 Without GNSS

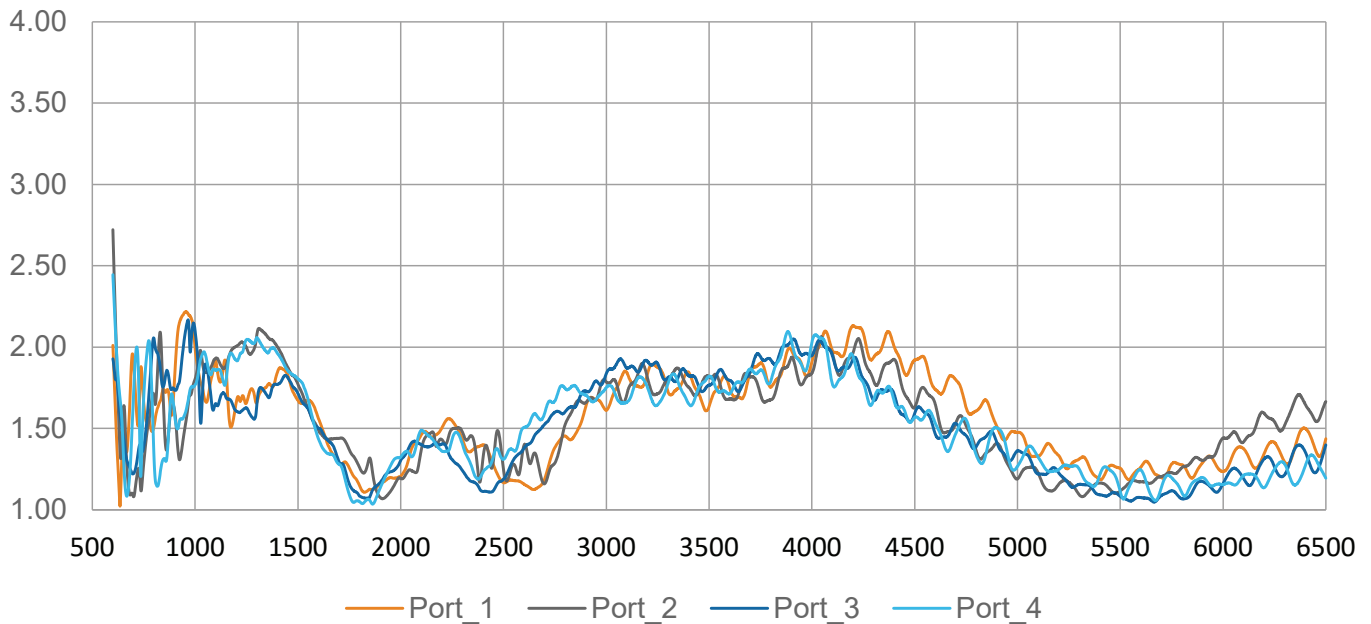

LTE - ISOLATION

Isolation (dB)

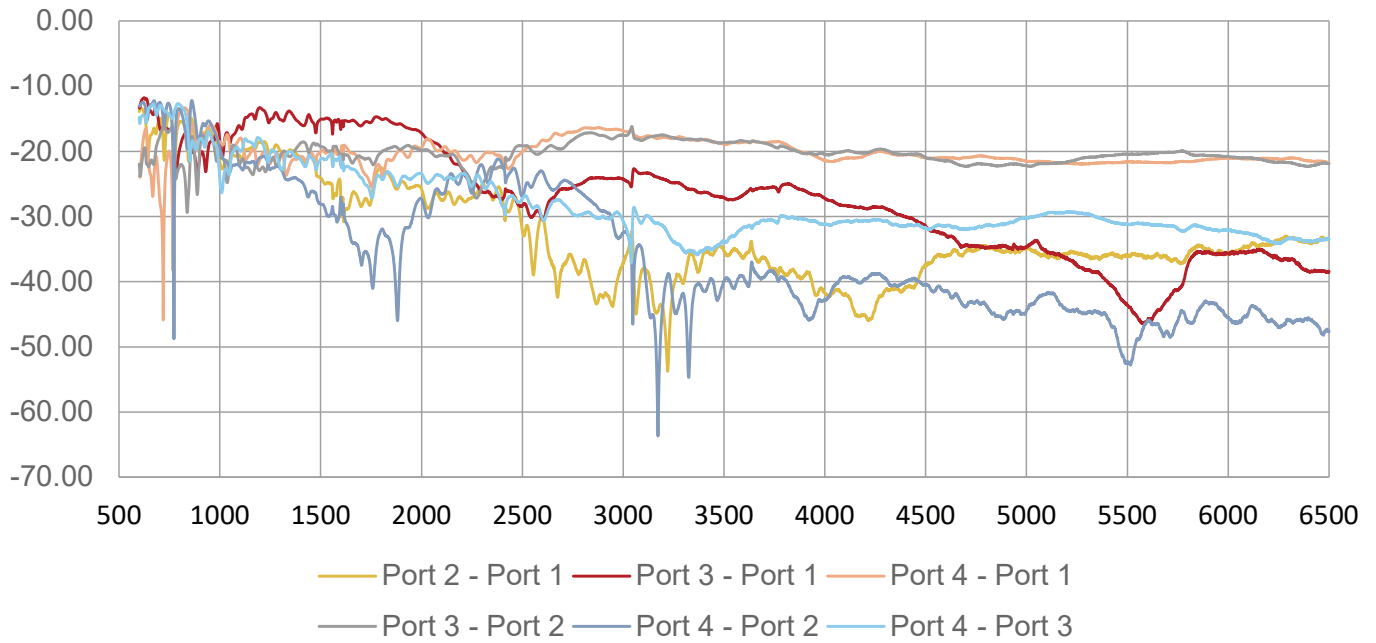

LTE - EFFICIENCY

Efficiency (%)

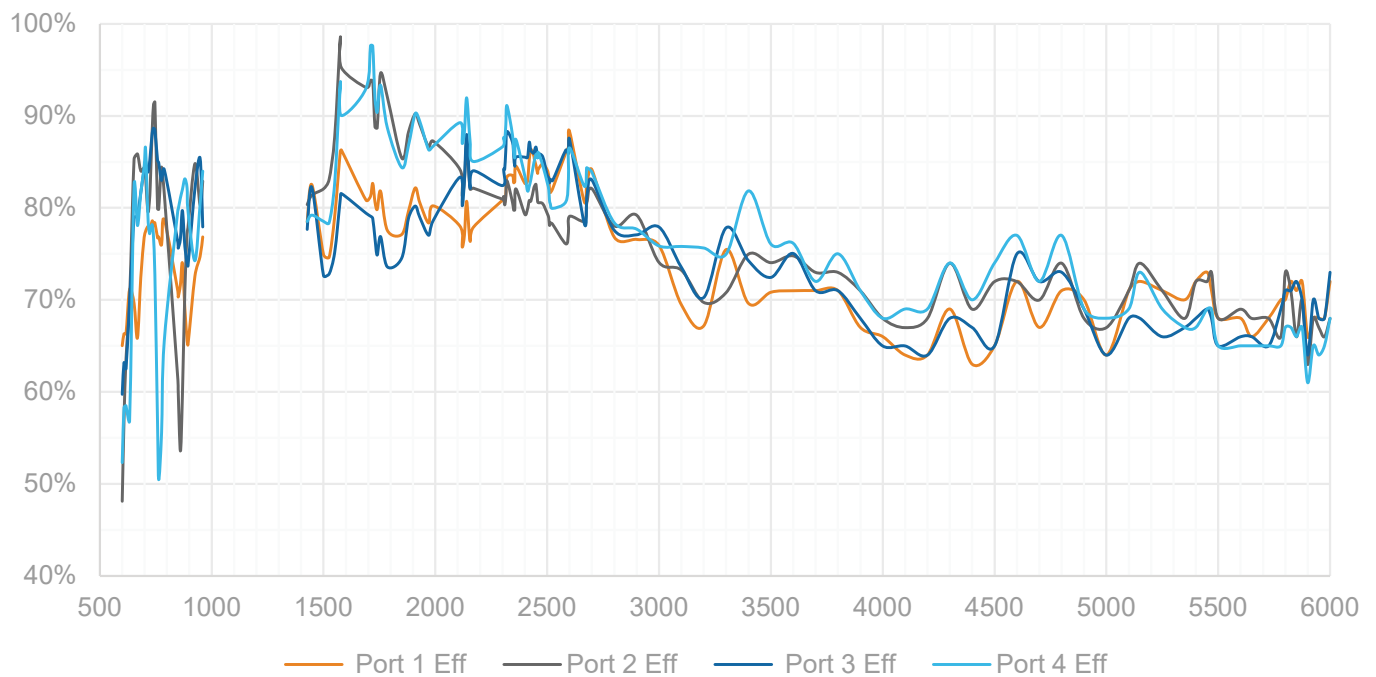

LTE - PEAK GAIN

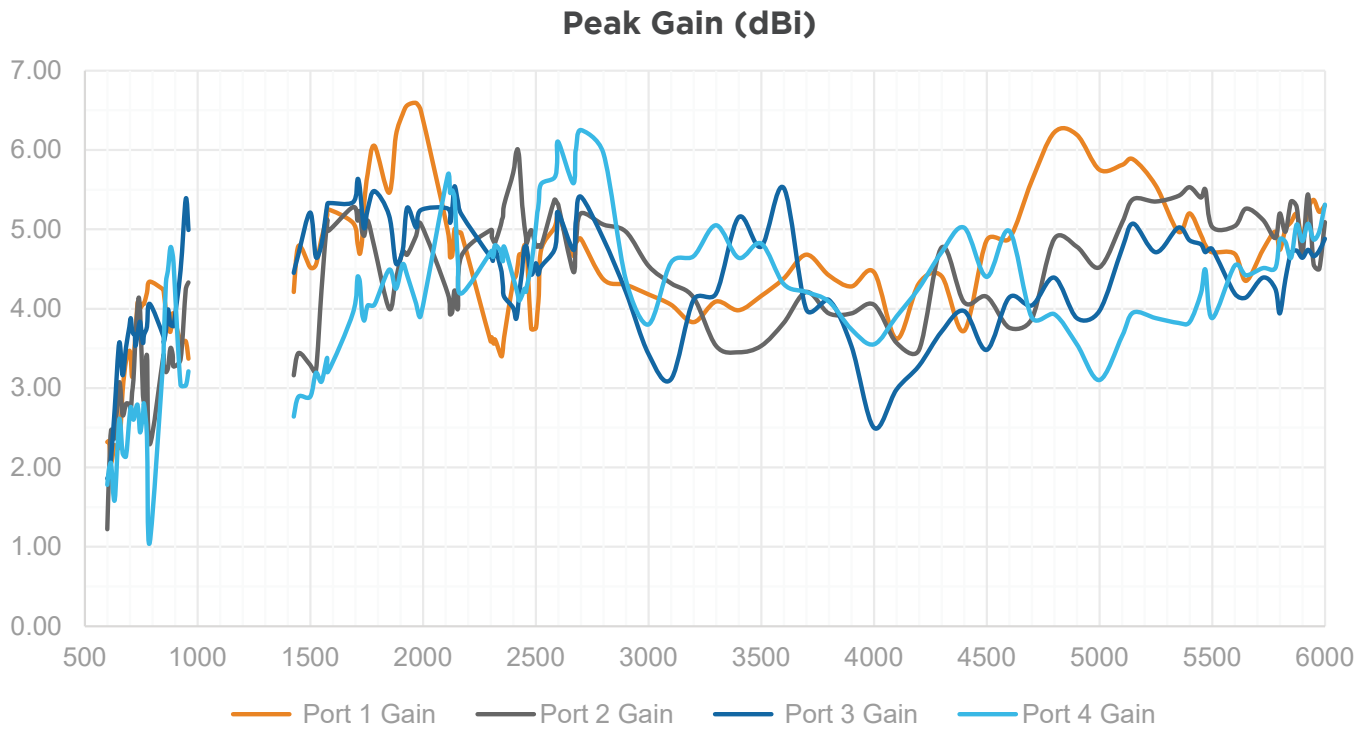

RADIATION PATTERNS

633 MHz

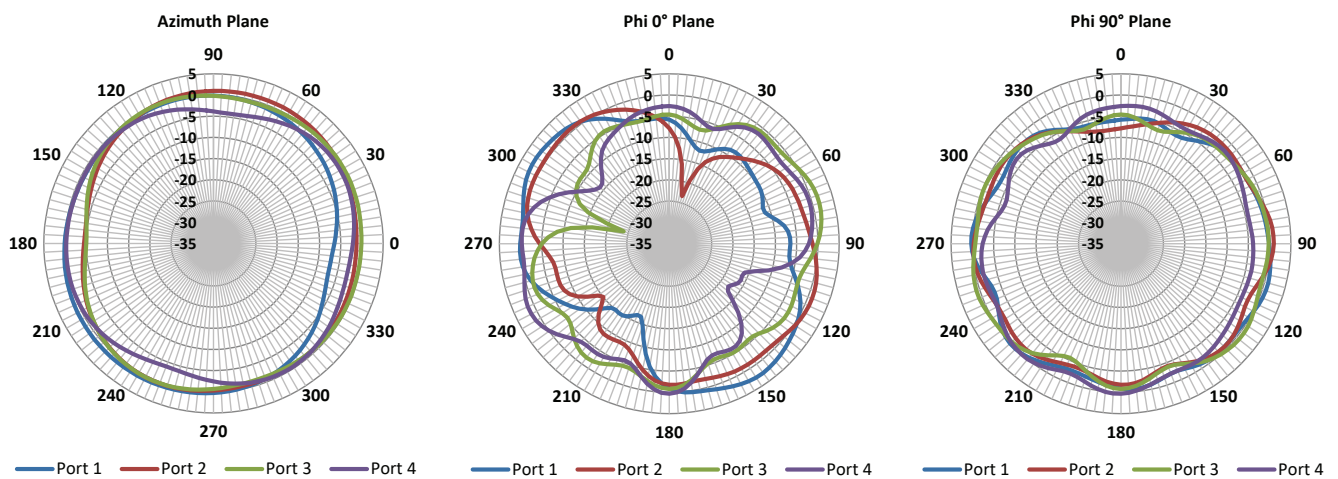

725 MHz

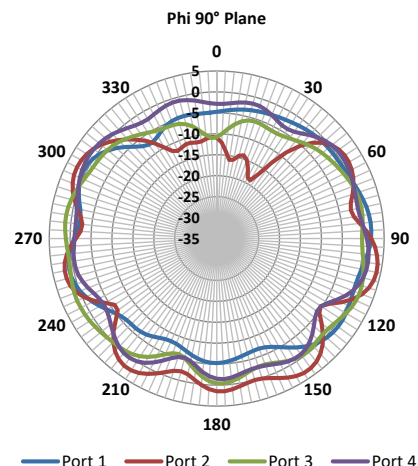
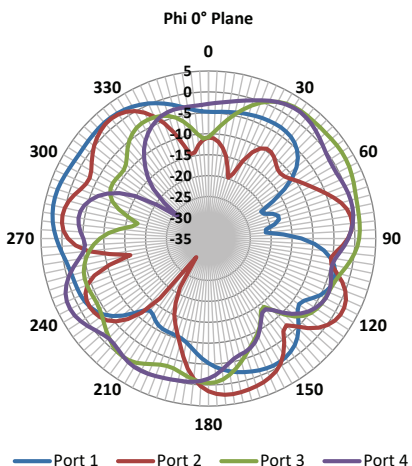
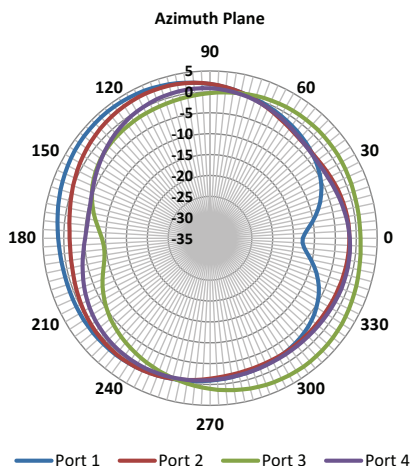

850 MHz

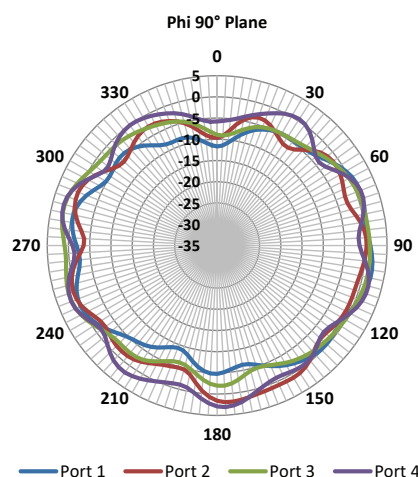
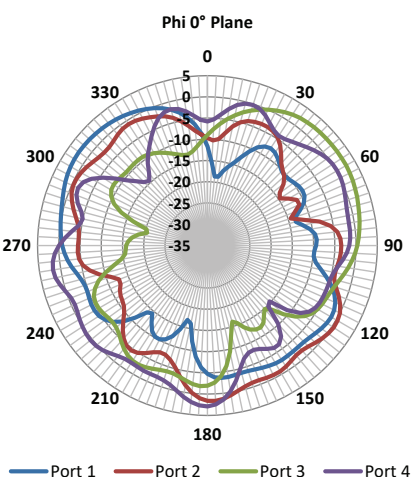
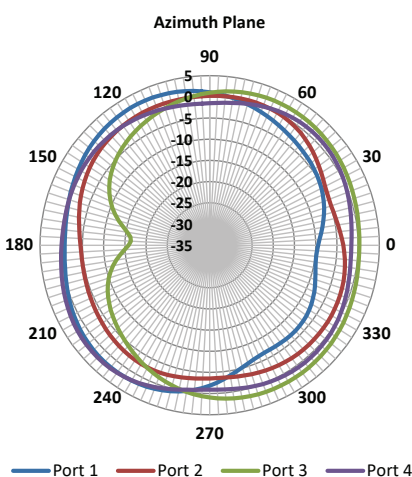

925 MHz

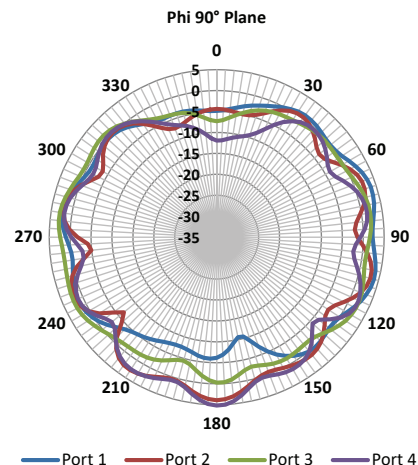
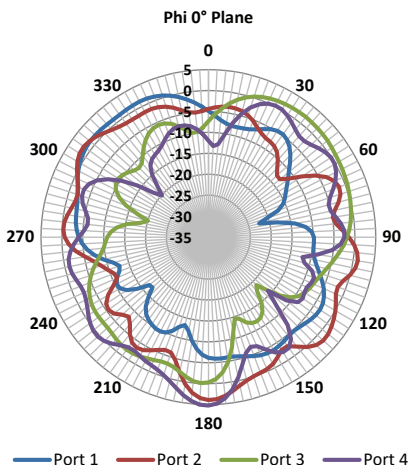
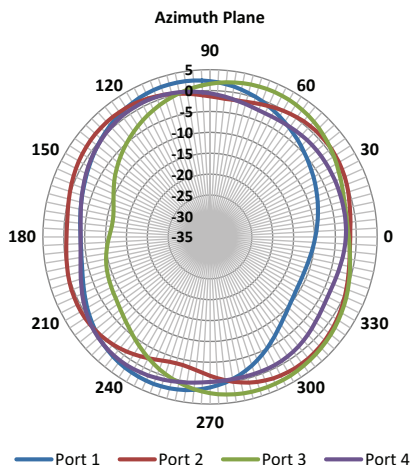

1448 MHz

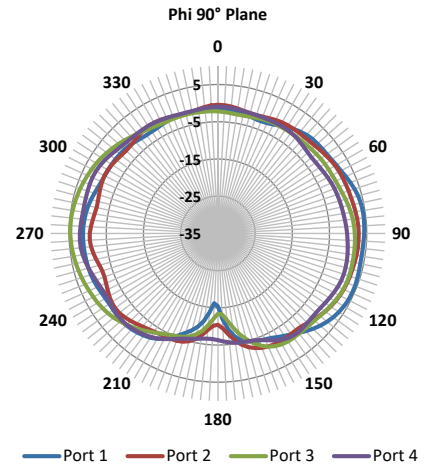
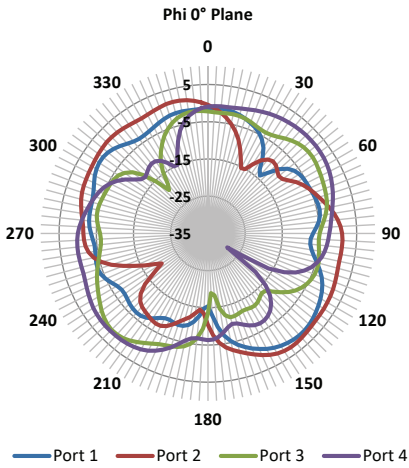
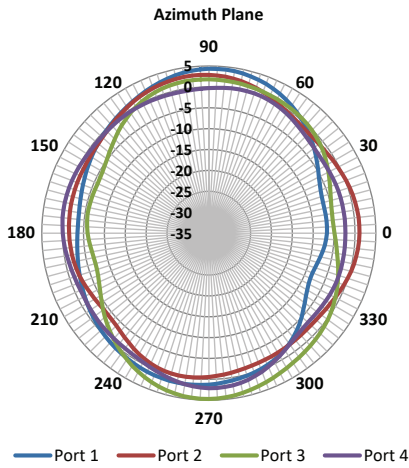

1730 MHz

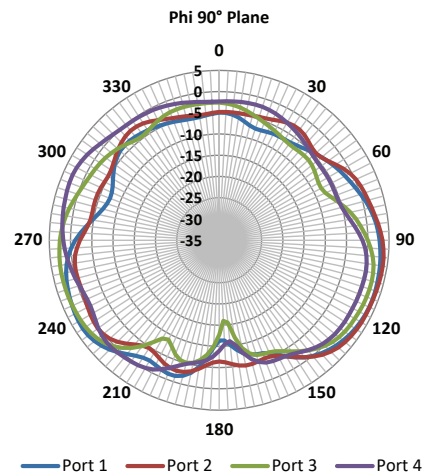
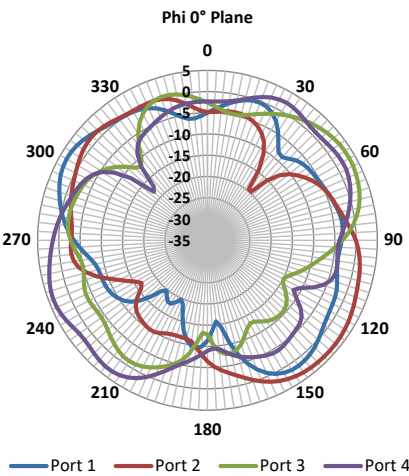
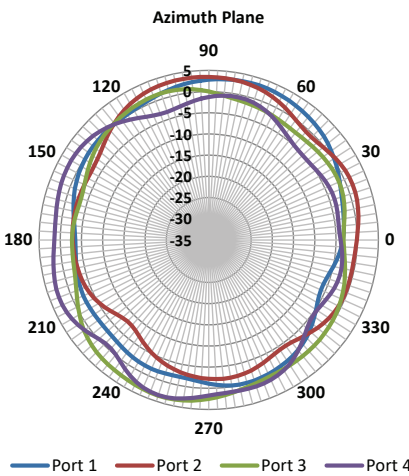

1930 MHz

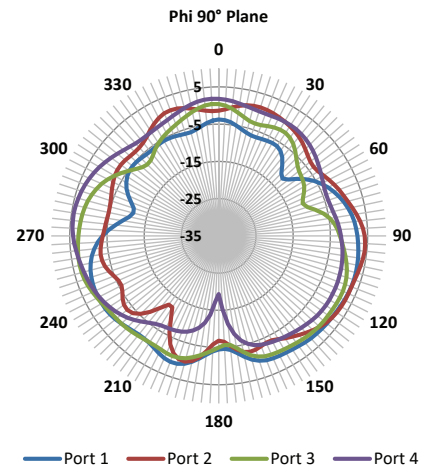
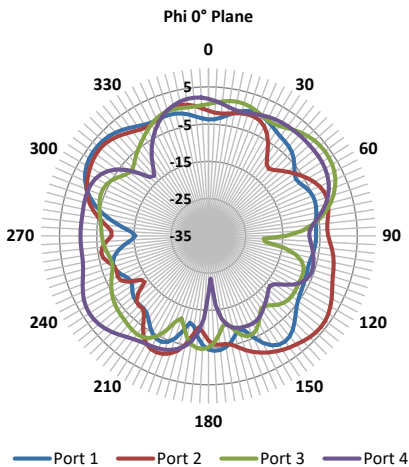
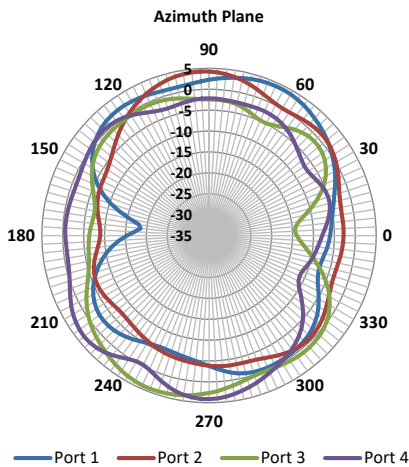

2130 MHz

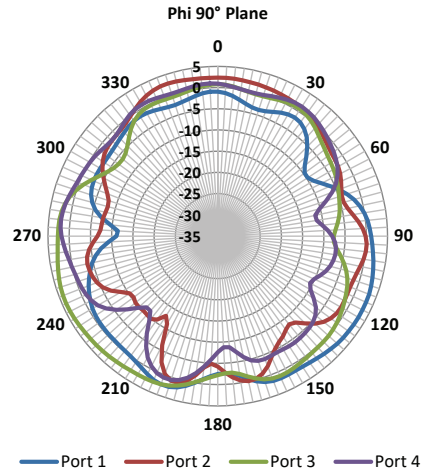
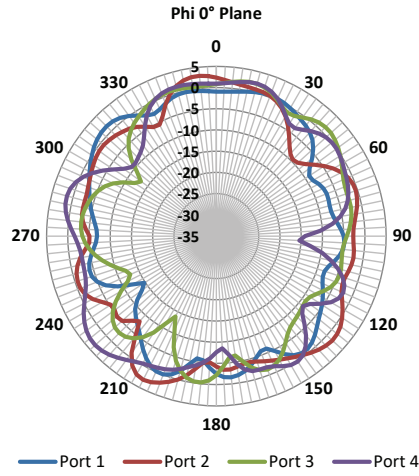
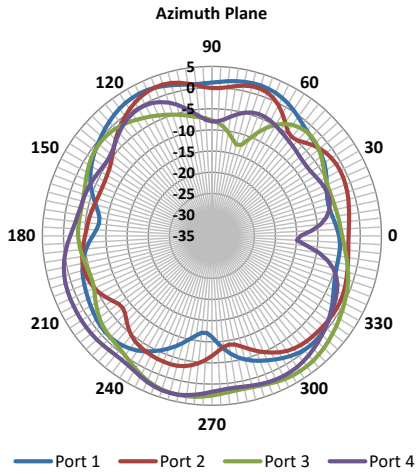

2310 MHz

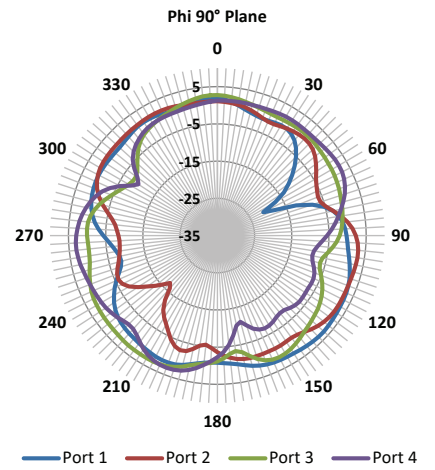
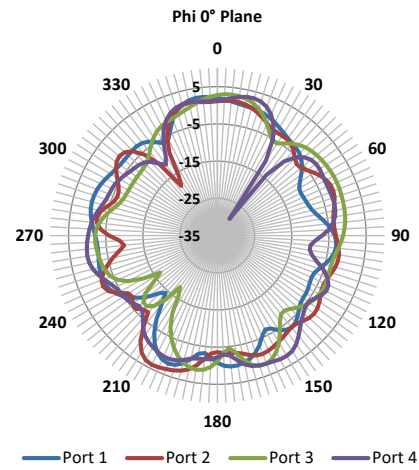
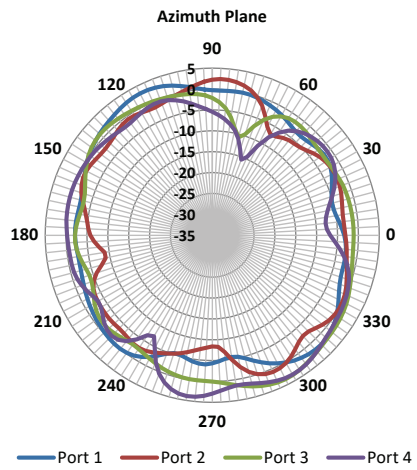

2600 MHz

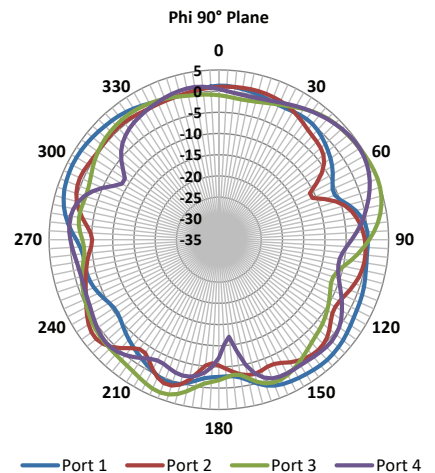
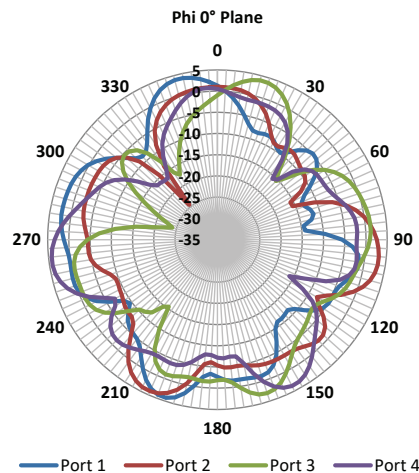
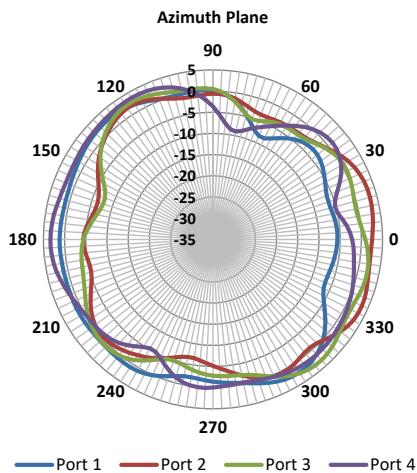

2700 MHz

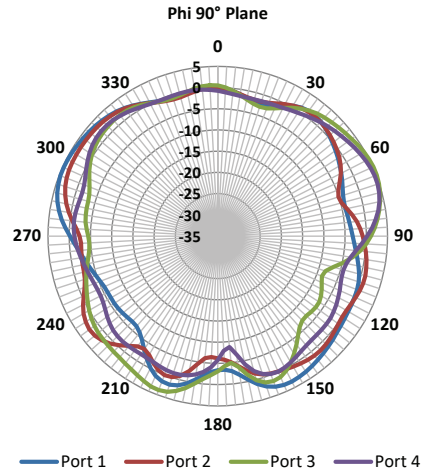
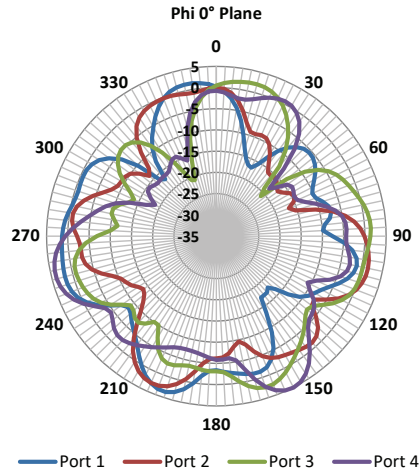
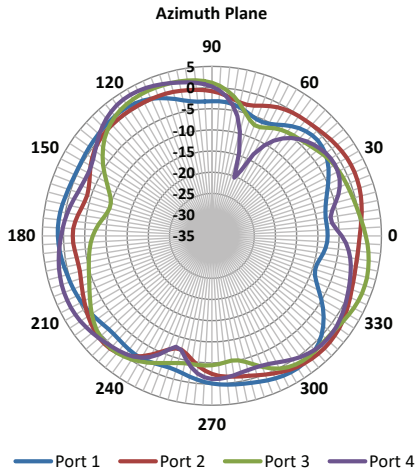

3300 MHz

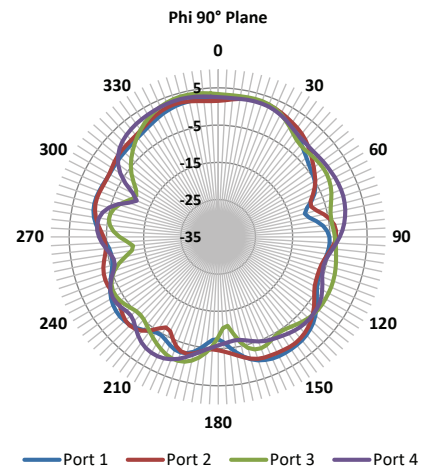
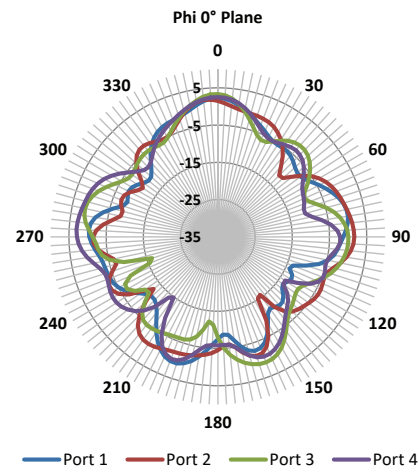
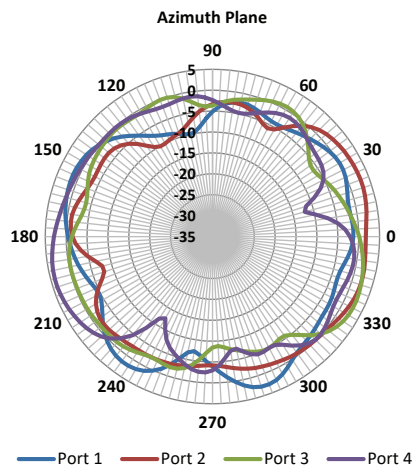

3500 MHz

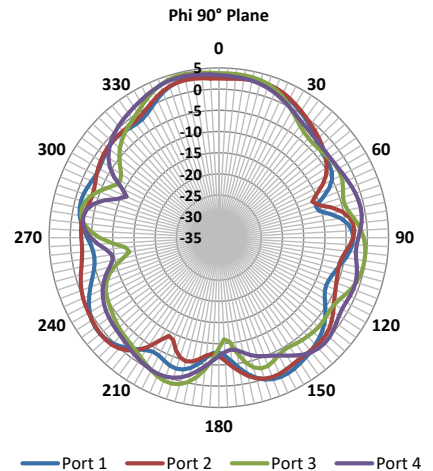
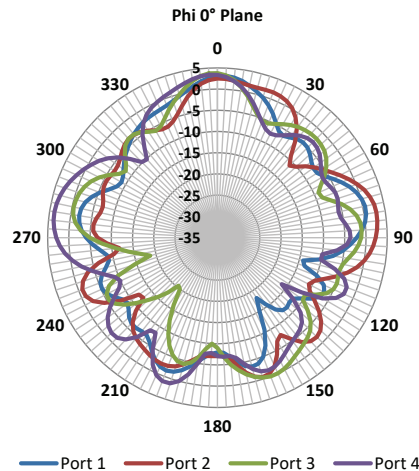
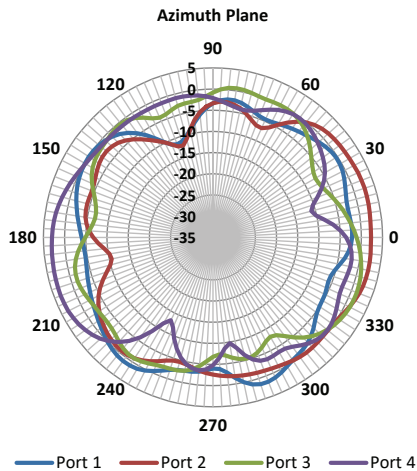

5500 MHz

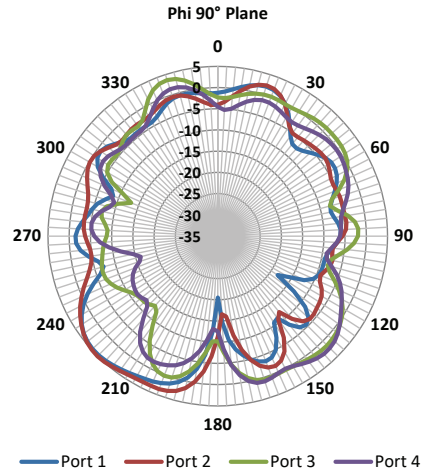
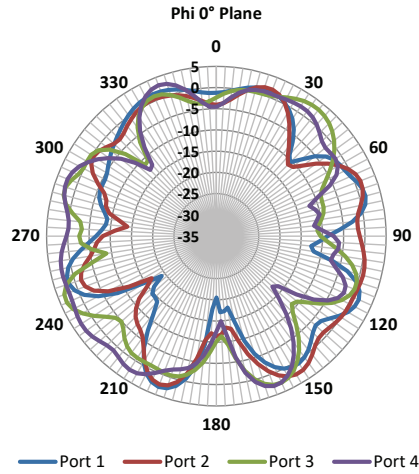
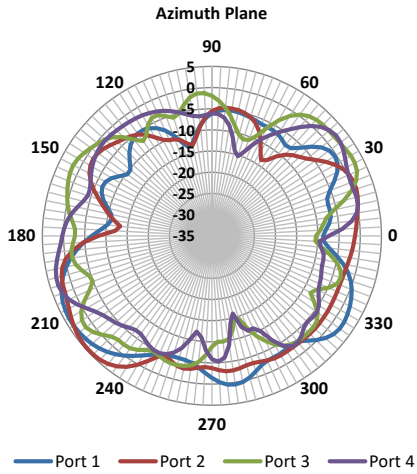

5800 MHz

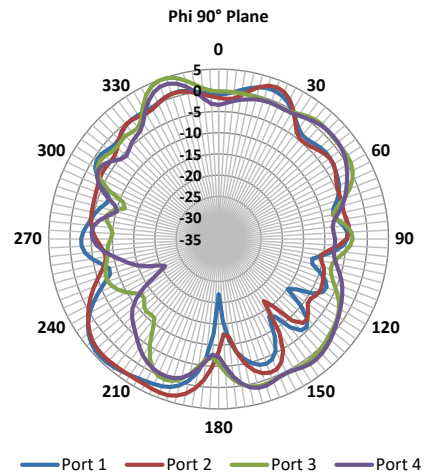
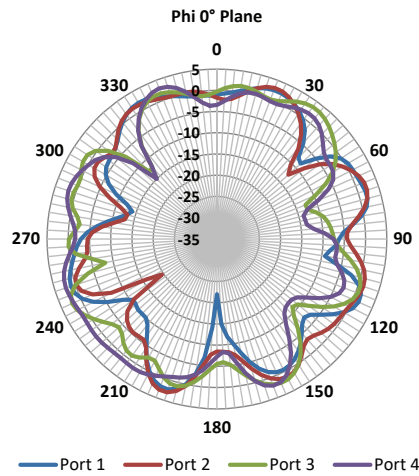
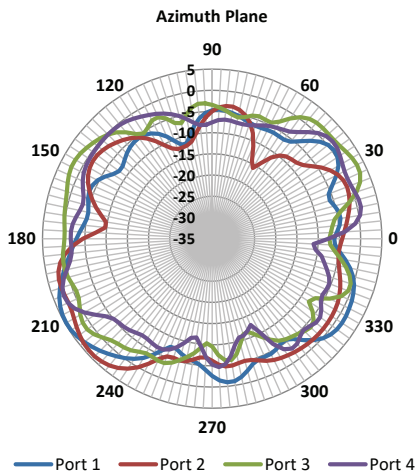

6000 MHz

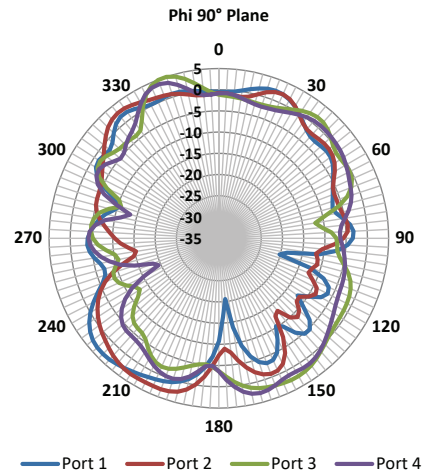
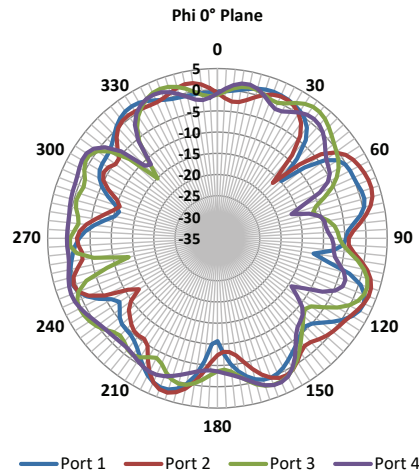
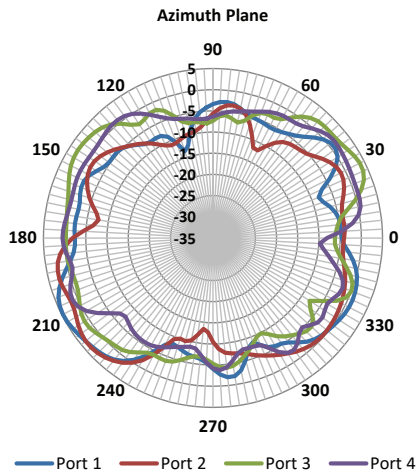

PACKAGING

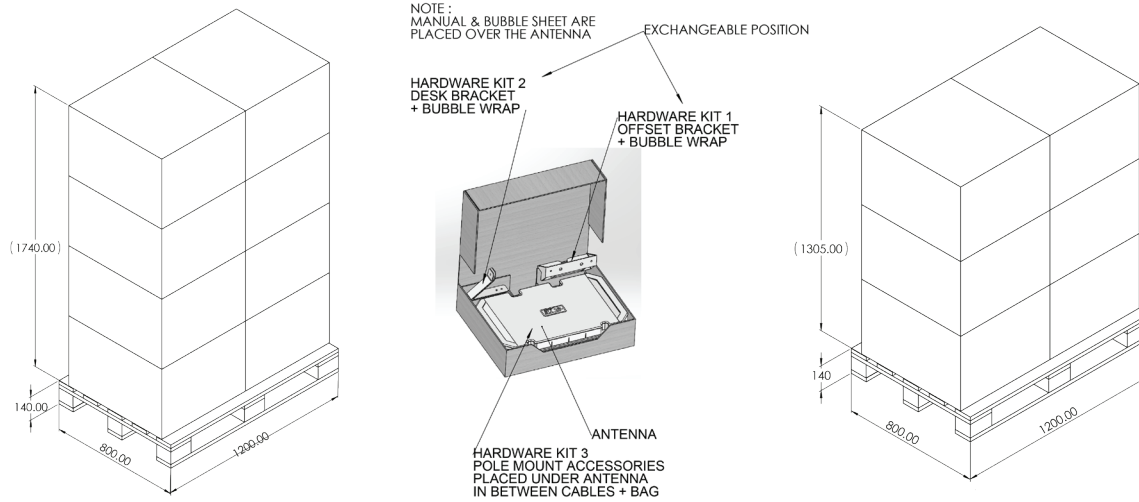

Ocean Shipping Standard Configuration Information

- Pallet 120cm x 80cm x 14cm, Weight 12 kg
- Single unit carton: Weight 2.6 kg
- Master carton @ 12 unit: Weight 33.0 kg
- Pallet @ 8 master cartons per pallet: Weight 276 kg (120 x 80 x 174cm) 96 total units per pallet

Air Shipping Standard Configuration Information

- Pallet 120cm x 80cm x 14cm, Weight 12kg
- Single unit carton: Weight 2.6 kg
- Master carton @ 12 unit: Weight 33.0 kg
- Pallet @ 6 master cartons per pallet: Weight 163.2kg (120 x 80 x 130.5cm) 72 total units per pallet

PACKAGED DIMENSIONS	UNIT CARTON	MASTER CARTON	AIR PALLET	OCEAN PALLET
Number of Antennas	1	12	72	96
Height cm (in)	9.0 (3.54)	43.5 (17.13)	144.5 (56.89)	188.4 (74.17)
Length cm (in)	38.3 (15.08)	60.0 (23.6)	120 (47.24)	120 (47.24)
Width cm (in)	31.5 (12.4)	66.5 (26.18)	80.0 (31.5)	80 (31.5)
Est. Shipping Weight* kg (lbs.) *Including Mounting Kits	2.6 (5.8)	33.0 (72.7)	210 (463.0)	276 (608.5)

te.com

TE, and TE connectivity (logo) are trademarks owned or licensed by the TE Connectivity Ltd. family of companies. All other logos, products and/or company names referred to herein might be trademarks of their respective owners.

The information given herein, including drawings, illustrations and schematics which are intended for illustration purposes only, is believed to be reliable. However, TE Connectivity makes no warranties as to its accuracy or completeness and disclaims any liability in connection with its use. TE Connectivity's obligations shall only be as set forth in TE Connectivity's Standard Terms and Conditions of Sale for this product and in no case will TE Connectivity be liable for any incidental, indirect or consequential damages arising out of the sale, resale, use or misuse of the product. Users of TE Connectivity products should make their own evaluation to determine the suitability of each such product for the specific application.

TE Connectivity warrants to the original end user customer of its products that its products are free from defects in material and workmanship. Subject to conditions and limitations TE Connectivity will, at its option, either repair or replace any part of its products that prove defective because of improper workmanship or materials. This limited warranty is in force for the useful lifetime of the original end product into which the TE Connectivity product is installed. Useful lifetime of the original end product may vary but is not warranted to exceed one (1) year from the original date of the end product purchase.

©2023 TE Connectivity. All Rights Reserved.

08/23 Original

TE TECHNICAL SUPPORT CENTER

USA:	+1 (800) 522-6752
Canada:	+1 (905) 475-6222
Mexico:	+52 (0) 55-1106-0800
Latin/S. America:	+54 (0) 11-4733-2200
Germany:	+49 (0) 6251-133-1999
UK:	+44 (0) 800-267666
France:	+33 (0) 1-3420-8686
Netherlands:	+31 (0) 73-6246-999
China:	+86 (0) 400-820-6015