

15W

AC-DC POWER SUPPLIES

The EML15 is a series of open frame and encapsulated AC-DC single output power supplies designed for medical applications. The series provides a number of flexible mechanical options including PCB mount, open frame, chassis mount with screw terminals and a DIN Rail option. With approvals to world-wide medical safety standards, compliance with class B for both conducted and radiated emissions and a 130%, 30s peak load capability, these class II isolation parts benefit system designers with easy integration into the latest healthcare products and applications.



Features

- Compact size
- Medical approvals
- Single outputs from 3.3 to 48V
- PCB mount, open frame and chassis mount
- Encapsulated PCB and chassis mount
- Class II
- Peak load capability
- 3 year warranty

Applications



Healthcare



Home Healthcare



Medical Diagnostic

Dimensions

EML15:

(-P): 2.44 x 1.21 x 0.95" (62.0 x 30.7 x 24.1 mm)

(-T): 3.10 x 1.25 x 0.91" (78.7 x 31.8 x 23.1 mm)

(-E): 2.56 x 1.31 x 0.96" (65.0 x 33.3 x 24.4 mm)

(-S): 3.30 x 1.36 x 1.04" (84.0 x 34.5 x 26.4 mm)

Models & Ratings

Model Number ^(2,3)	Output Voltage	Output Current		Efficiency	Output Power
		Nominal	Peak ⁽¹⁾		
EML15US03	3.3VDC	3.00A	3.90A	75%	10W
EML15US05	5.0VDC	3.00A	3.90A	78%	15W
EML15US09	9.0VDC	1.67A	2.17A	80%	15W
EML15US12	12.0VDC	1.25A	1.62A	80%	15W
EML15US15	15.0VDC	1.00A	1.30A	80%	15W
EML15US24	24.0VDC	0.63A	0.82A	82%	15W
EML15US36	36.0VDC	0.42A	0.54A	82%	15W
EML15US48	48.0VDC	0.32A	0.41A	82%	15W

Notes:

1. Peak load lasting <30 s with a maximum duty cycle of 10%, average output power not to exceed nominal.
2. Add suffix to model number to define type: add '-P' for PCB mount, add '-T' for chassis mount, add '-E' for encapsulated, add '-S' for screw terminals.
3. A screw terminal version (-S) is available with DIN clip attached, add suffix 'D', e.g. EML15US24-SD, DIN rail mounting kit is available as a separate item, order code EML15 DIN CLIP.

Summary

Characteristic	Minimum	Typical	Maximum	Units	Notes & Conditions
Input Voltage Range	85		264	VAC	
	120		370	VDC	
No Load Input Power			0.3	W	
Efficiency	75	80	82	%	See Models & Ratings
Operating Temperature	-20		+70	°C	Derate linearly from 100% at +50°C to 50% at +70°C
EMC	EN55032 Level B Conducted & Radiated, EN61000-4, EN61000-3, EN60601-1-2				
Safety Approvals	EN60601-1, ANSI/AAMI ES60601-1. IEC60601-1				

Input

Characteristic	Minimum	Typical	Maximum	Units	Notes & Conditions
Input Voltage Range	85		264	VAC	
	120		370	VDC	
Input Frequency	47		63	Hz	
Input Current - Full Load		0.32/0.16		A rms	At 115/230VAC
No Load Input Power			0.3	W	
Inrush Current		20/40		A	At 115/230VAC
Earth Leakage Current					Class II construction no earth
Input Protection	T1AL/250V internal fuse fitted in line and neutral				

Output

Characteristic	Minimum	Typical	Maximum	Units	Notes & Conditions
Output Voltage	3		48	VDC	See Models & Ratings
Initial Set Accuracy			±1	%	
Output Voltage Adjustment			±5	%	Not encapsulated units
Minimum Load	0			A	No minimum load required
Line Regulation			±0.5	%	
Load Regulation			±1	%	
Touch Current			40	µA	N.C.
			80		SFC
Start Up Delay			2	s	
Start Up Rise Time			14	ms	
Hold Up Time	12			ms	At full load and 115VAC
Transient Response			4	%	Deviation, recovery within 1% in less than 500µs for a 25% load change
Ripple & Noise			50	mV pk-pk	3.3-5V, 20MHz bandwidth
			120	mV pk-pk	12-15V, 20MHz bandwidth
			200	mV pk-pk	24-48V, 20MHz bandwidth
Overvoltage Protection	195		216	% Vnom	3.3V versions, recycle input to reset
	115		130	% Vnom	All other versions, recycle input to reset
Overload Protection	110		180	%	
Short Circuit Protection					Trip & Restart (hiccup mode)
Temperature Coefficient			0.05	%/°C	

General

Characteristic	Minimum	Typical	Maximum	Units	Notes & Conditions
Efficiency	75	80	82	%	See Models & Ratings
Isolation: Input to Output	4000			VAC	
Switching Frequency		70		kHz	
Power Density			4.8	W/in ³	PCB Mount version
Mean Time Between Failure		>400		khrs	MIL-HDBK-217F, +25°C GB
Weight		0.07 (35)		lb (g)	Open frame versions (-P)
		0.20 (90)			Encapsulated version
		0.24 (110)			Screw terminal version

Safety Approvals

Certification	Standard	Notes & Conditions
CB Report	IEC60601-1	Medical
UL	ANSI/AAMI ES60601-1 & CSA C22.2, No.60601-1	Medical
TUV	EN60601-1	
CE	Meets all applicable directives	
UKCA	Meets all applicable legislation	
	Means of Protection	Category
Primary to Secondary	2 x MOPP (Means of Patient Protection)	IEC60601-1

Environmental

Characteristic	Minimum	Typical	Maximum	Units	Notes & Conditions
Operating Temperature	-20		+70	°C	Derate linearly from 100% at +50 °C to 50% at +70 °C
Storage Temperature	-40		+85	°C	
Cooling	Convection-cooled				
Humidity			95	%RH	Non-condensing
Operating Altitude			3048	m	
Shock	IEC68-2-27, 30g, 11ms half sine, 3 times in each of 6 axes				
Vibration	IEC68-2-6, 2g, 10Hz to 500kHz, 10 mins/cycle, 60 mins each cycle				

EMC: Emissions

Phenomenon	Standard	Test Level	Notes & Conditions
Conducted	EN55032/11	Class B	
Radiated	EN55032/11	Class B	
Harmonic Current	EN61000-3-2	Class A	
Voltage Flicker	EN61000-3-3		

EMC: Immunity

Phenomenon	Standard	Test Level	Criteria	Notes & Conditions	
ESD Immunity	EN61000-4-2	4	A		
Radiated Immunity	EN61000-4-3	10 V/m	A	80% mod	
EFT/Burst	EN61000-4-4	3	A		
Surge	EN61000-4-5	3	A		
Conducted	EN61000-4-6	10Vrms	A		
Magnetic Fields	EN61000-4-8	10A/m	A		
Dips and Interruptions	EN60601-1-2	70% U_T for 500ms	A	40% of UT dip is performance criteria A if load is reduced to 45% based on 100VAC	
		40% U_T for 100ms	A		
		<5% U_T for 10ms	A		
		<5% U_T for 5000ms	B		
	EN60601-1-2 4th Ed	70% U_T for 500ms	A		
		0% U_T for 20ms	A		
		0% U_T for 5000ms	B		

Mechanical Details

Open Frame - PCB Mount (-P)

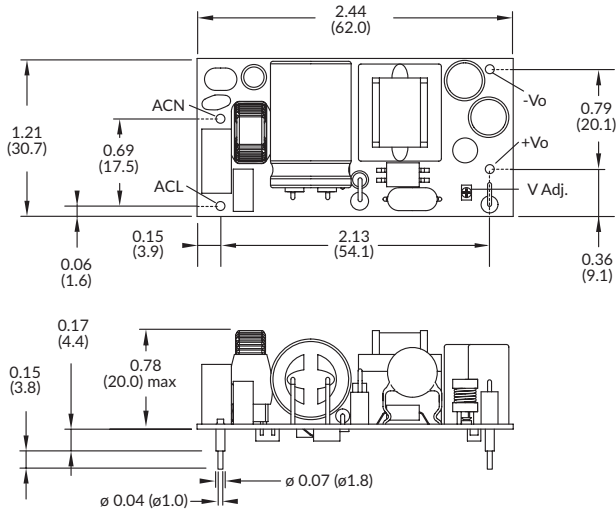

Encapsulated (-E)

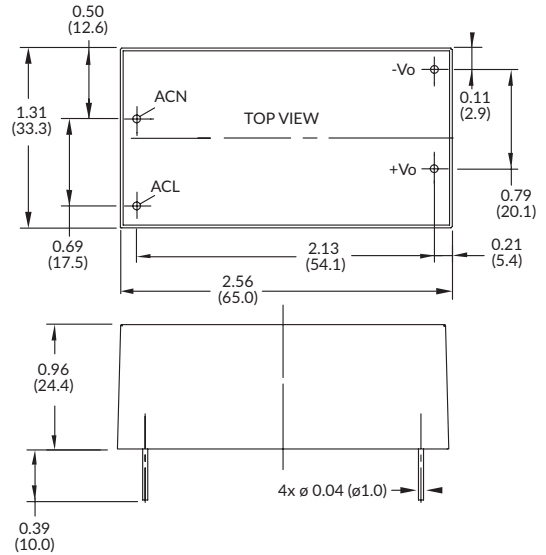

Open Frame - Chassis Mount (-T)

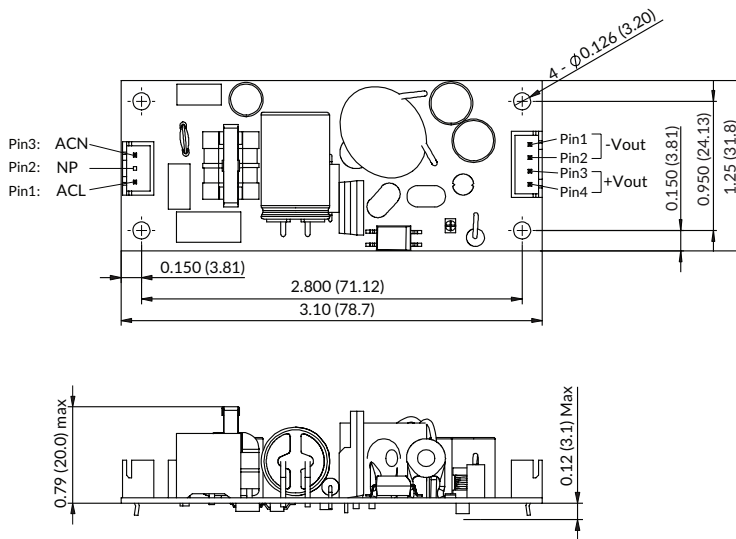

Screw Terminal (-S)

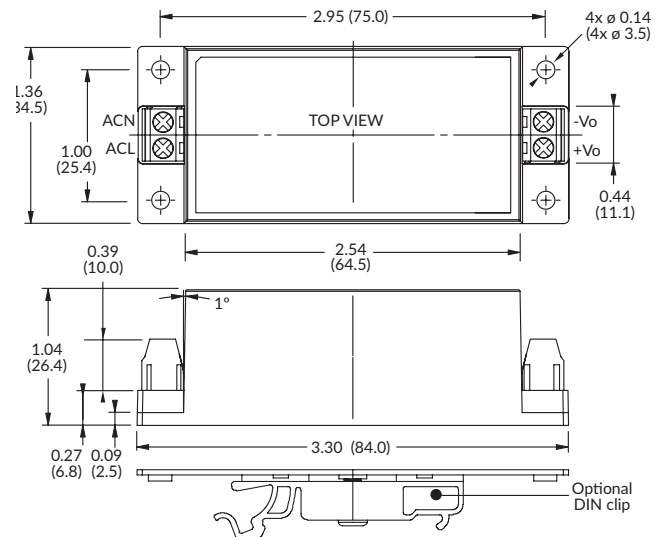

Notes:

1. Dimensions in inches (mm).
2. Weight: P Version: 0.07 lbs (35 g) T Version: 0.07 lbs (35 g) E Version: 0.20 lbs (9g) S Version: 0.24 lbs (110 g)
3. Tolerances: $x.xx = \pm 0.02$ ($x.x = \pm 0.5$) $x.xxx = \pm 0.01$ ($x.xx = \pm 0.25$)

Mating Connectors (-T version only)

- Input Connector: JST XHP-3
 Output Connector: JST XHP-4
 Crimps: SXH-001T-P0.6