

RSL112100-S

REV	ECN	DESCRIPTION	APP'D
-	2415	RELEASE	JR 5/30/95
A	2949	ADD SILKSCREEN CALLOUT	

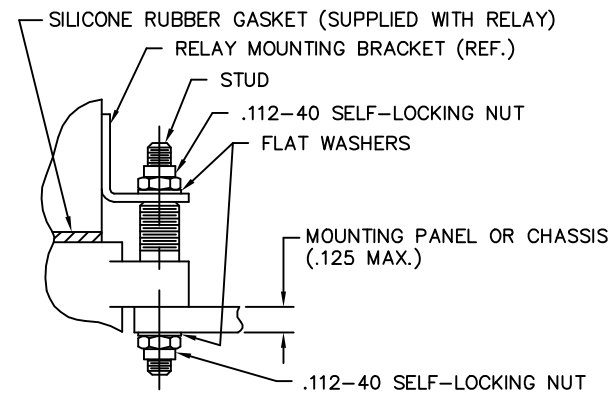

TOP MOUNT

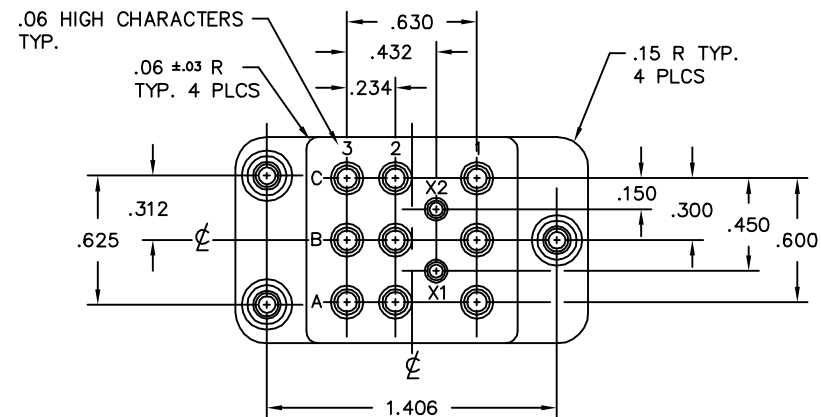
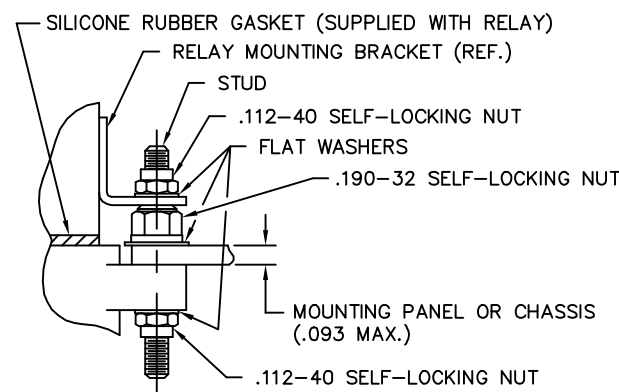
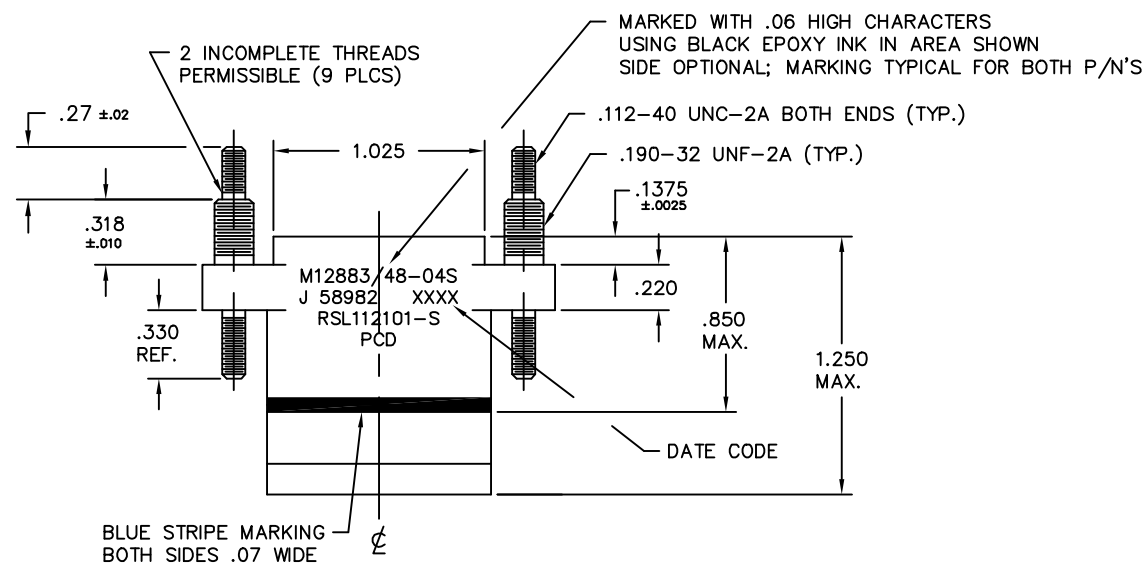

BOTTOM MOUNT

NOTES:

- HOUSING SHALL BE THERMOPLASTIC MOLDING MATERIAL COLOR: BLUE-GREEN.
- SEALING GROMMET MATERIAL SHALL BE SILICONE RUBBER PER ZZ-R-765, COLOR: RED.
- SOCKET CONTACT SHALL BE COPPER ALLOY GOLD PLATED PER MIL-G-45204, TYPE II, GRADE C, CLASS 1.
- STUD MATERIAL AND MOUNTING HARDWARE SHALL BE STAINLESS STEEL PASSIVATED UNLESS OTHERWISE SPECIFIED.
- SOCKET CONTACTS ARE OF CLOSED ENTRY TYPE AND DESIGNED TO COMPLY WITH TEST REQUIREMENTS OF MIL-C-39029 INCLUDING CRIMP TERMINATION.
- M22520/1-01 CRIMP TOOL AND M22520/1-02 POSITIONER SHALL BE USED TO TERMINATE SOCKET CONTACTS TO THEIR RESPECTIVE WIRE SIZES.
- M81969/14-03 AND -04 TOOL SHALL BE USED FOR INSERTING AND REMOVING WIRED SOCKET CONTACTS.
- ALL HARDWARE SUPPLIED UNASSEMBLED IN SEPERATE RIGID CONTAINER WITHIN SOCKET PACKAGE.
- CONTACTS SUPPLIED UNASSEMBLED IN SEPERATE RIGID CONTAINER WITHIN SOCKET PACKAGE, SEE TABLE.
- WEIGHT: .132 LBS. (60g) MAX., INCLUDING HARDWARE AND CONTACTS.
- INSTALLATION TORQUE REQUIREMENTS:  
THREAD SIZE .112-40 = 4 ±1 IN.-LBS.  
THREAD SIZE .190-32 = 18 ±1 IN.-LBS.
- THE SEALING GROMMET IS DESIGNED TO SEAL OVER THE FOLLOWING WIRE DIA.'S: SIZE 16 .065 MIN. TO .109 MAX; SIZE 12 .097 MIN. TO .142 MAX.
- UNIT PACKAGE RELAY SOCKET PER EC-034, TYPE II.

RSL112100-S

RSL112100-S

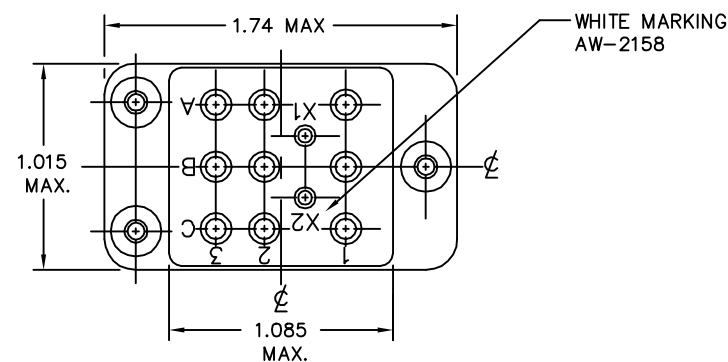

RSL112101-S	9 SIZE 12/12 SOCKET CONTACT 2 SIZE 16/16 SOCKET CONTACT	CNS511800 CNS511600	RSL112101-S
RSL112100-S	NONE	NONE	
PCD P/N	CONTACTS SUPPLIED	CONTACT P/N	MARKING

DIMENSIONS	TOLERANCES	PROJECTION	REFERENCE SPECIFICATION	TITLE		
ANSI Y14.5M UNITS: INCHES CRITICAL: ◆	.XX ±.01 .XXX ±.005 ANGLES ±2'		M12883/48-04S DRWN A. PATRIE 5/15/95 ENGR J. RUTKOWSKI 5/30/95 APPD		RELAY SOCKET 9 POS, SIZE 12/12 2 POS, SIZE 16/16	
ORIGINAL NOT FOR CUSTOMER DISTRIBUTION	THIS DOCUMENT CONTAINS PROPRIETARY INFORMATION WHICH IS THE CONFIDENTIAL PROPERTY OF PCD, INC. PEABODY, MA, USA		SIZE B		DWG NO. RSL112100-S	REV A
				CODE: 58982	SCALE: NONE	SHEET 1 OF 1