

Automotive-grade N-channel 650 V, 89 mΩ typ., 32 A MDmesh DM6 half-bridge topology Power MOSFET in an ACEPACK SMIT package

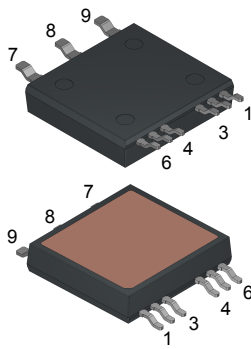

ACEPACK SMIT

GADG060720221002SA

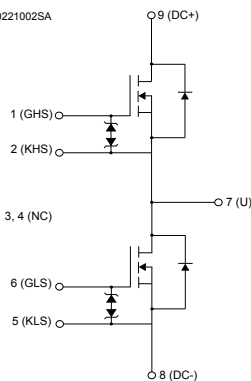

Features

Order code	V_{DS}	$R_{DS(on)}$ max.	I_D
SH32N65DM6AG	650 V	97 mΩ	32 A

- AQG 324 qualified 
- Half-bridge power module
- 650 V blocking voltage
- Fast recovery body diode
- Very low switching energies
- Low package inductance
- Dice on direct bond copper (DBC) substrate
- Low thermal resistance
- Isolation rating of 3.4 kVrms/min

Applications

- Switching applications

Description

This device combines two MOSFETs in a half-bridge topology. The ACEPACK SMIT is a very compact and rugged power module in a surface mount package for easy assembly. Thanks to the DBC substrate, the ACEPACK SMIT package offers low thermal resistance coupled with an isolated top-side thermal pad. The high design flexibility of the package enables several configurations, including phase legs, boost, and single switch through different combinations of the internal power switches.

Product status link

[SH32N65DM6AG](#)

Product summary

Order code	SH32N65DM6AG
Marking	H32N65DM6
Package	ACEPACK SMIT
Packing	Tape and reel

1 Electrical ratings

Table 1. Absolute maximum ratings

Symbol	Parameter	Value	Unit
V_{GS}	Gate-source voltage	± 25	V
I_D	Drain current (continuous) at $T_C = 25\text{ }^\circ\text{C}$	32	A
	Drain current (continuous) at $T_C = 100\text{ }^\circ\text{C}$	20	
$I_{DM}^{(1)}$	Drain current (pulsed)	120	A
P_{TOT}	Total power dissipation at $T_C = 25\text{ }^\circ\text{C}$	208	W
$dv/dt^{(2)}$	Peak diode recovery voltage slope	100	V/ns
$di/dt^{(2)}$	Peak diode recovery current slope	1000	A/ μs
$dv/dt^{(3)}$	MOSFET dv/dt ruggedness	100	V/ns
V_{ISO}	Isolation withstand voltage applied between each pin and heat sink plate (AC voltage (50/60 Hz, $t = 60\text{ s}$))	3.4	kVrms
T_{STG}	Storage temperature range	-55 to 150	$^\circ\text{C}$
T_J	Operating junction temperature range		$^\circ\text{C}$

1. Pulse width limited by safe operating area.
2. $I_{SD} \leq 32\text{ A}$, $V_{DS}(\text{peak}) < V_{(BR)DSS}$, $V_{DD} = 400\text{ V}$.
3. $V_{DS} \leq 520\text{ V}$.

Table 2. Thermal data

Symbol	Parameter	Value	Unit
R_{thJC}	Thermal resistance, junction-to-case	0.6	$^\circ\text{C}/\text{W}$

Table 3. Avalanche characteristics

Symbol	Parameter	Value	Unit
I_{AR}	Avalanche current, repetitive or not repetitive (t_p limited by T_J max)	6	A
E_{AS}	Single pulse avalanche energy (starting $T_J = 25\text{ }^\circ\text{C}$, $I_D = I_{AR}$)	778	mJ

2 Electrical characteristics

$T_C = 25\text{ }^\circ\text{C}$ unless otherwise specified

Table 4. On/off states

Symbol	Parameter	Test conditions	Min.	Typ.	Max.	Unit
$V_{(BR)DSS}$	Drain-source breakdown voltage	$V_{GS} = 0\text{ V}, I_D = 1\text{ mA}$	650			V
I_{DSS}	Zero gate voltage drain current	$V_{GS} = 0\text{ V}, V_{DS} = 650\text{ V}$			5	μA
		$V_{GS} = 0\text{ V}, V_{DS} = 650\text{ V}, T_C^{(1)}$			300	
I_{GSS}	Gate-body leakage current	$V_{DS} = 0\text{ V}, V_{GS} = \pm 25\text{ V}$			± 5	μA
$V_{GS(th)}$	Gate threshold voltage	$V_{DS} = V_{GS}, I_D = 250\text{ }\mu\text{A}$	3.25	4	4.75	V
$R_{DS(on)}$	Static drain-source on resistance	$V_{GS} = 10\text{ V}, I_D = 23\text{ A}$		89	97	m Ω

1. Specified by design, not tested in production.

Table 5. Dynamic characteristics

Symbol	Parameter	Test conditions	Min.	Typ.	Max.	Unit
C_{iss}	Input capacitance	$V_{DS} = 100\text{ V}, f = 1\text{ MHz}, V_{GS} = 0\text{ V}$	-	2211	-	pF
C_{oss}	Output capacitance		-	106	-	pF
C_{rSS}	Reverse transfer capacitance		-	0.3	-	pF
$C_{oss\ eq.}^{(1)}$	Equivalent output capacitance	$V_{DS} = 0\text{ to }520\text{ V}, V_{GS} = 0\text{ V}$	-	396	-	pF
R_G	Intrinsic gate resistance	$f = 1\text{ MHz}, I_D = 0\text{ A}$	-	1.5	-	Ω
Q_g	Total gate charge	$V_{DD} = 520\text{ V}, I_D = 37\text{ A}, V_{GS} = 0\text{ to }10\text{ V}$ (see Figure 13. Test circuit for gate charge behavior)	-	47	-	nC
Q_{gs}	Gate-source charge		-	16	-	nC
Q_{gd}	Gate-drain charge		-	18	-	nC

1. $C_{oss\ eq.}$ is defined as a constant equivalent capacitance giving the same charging time as C_{oss} when V_{DS} increases from 0 to 80% V_{DSS} .

Table 6. Switching characteristics (resistive load)

Symbol	Parameter	Test conditions	Min.	Typ.	Max.	Unit
$t_{d(on)}$	Turn-on delay time	$V_{DD} = 325\text{ V}, I_D = 18.5\text{ A},$ $R_G = 4.7\text{ }\Omega, V_{GS} = 10\text{ V}$	-	23	-	ns
t_r	Rise time		-	10	-	ns
$t_{d(off)}$	Turn-off delay time	(see Figure 12. Switching times test circuit for resistive load and Figure 17. Switching time waveform)	-	54	-	ns
t_f	Fall time		-	9	-	ns

Table 7. Switching characteristics (inductive load)

Symbol	Parameter	Test conditions	Min.	Typ.	Max.	Unit
$t_{d(v)}$	Voltage delay time	$V_{DD} = 400\text{ V}$, $V_{GS} = 0\text{ to }10\text{ V}$, $I_D = 37\text{ A}$,	-	54	-	ns
$t_{r(v)}$	Voltage rise time	$R_G = 6.8\ \Omega$ (see Figure 14. Test circuit for inductive load switching and diode recovery times and Figure 18. Turn-off switching time waveform on inductive load)	-	7	-	ns
$t_{f(i)}$	Current fall time		-	8	-	ns
$t_{c(off)}$	Crossing time off		-	13	-	ns
$t_{d(i)}$	Current delay time		$V_{DD} = 400\text{ V}$, $V_{GS} = 0\text{ to }10\text{ V}$, $I_D = 37\text{ A}$,	-	154	-
$t_{r(i)}$	Current rise time	$R_G = 82\ \Omega$ (see Figure 14. Test circuit for inductive load switching and diode recovery times and Figure 19. Turn-on switching time waveform on inductive load)	-	59	-	ns
$t_{f(v)}$	Voltage fall time		-	9	-	ns
$t_{c(on)}$	Crossing time on		-	128	-	ns

Table 8. Source-drain diode

Symbol	Parameter	Test conditions	Min.	Typ.	Max.	Unit
I_{SD}	Source-drain current		-		32	A
$I_{SDM}^{(1)}$	Source-drain current (pulsed)		-		120	A
$V_{SD}^{(2)}$	Forward on voltage	$V_{GS} = 0\text{ V}$, $I_{SD} = 32\text{ A}$	-		1.6	V
t_{rr}	Reverse recovery time	$I_{SD} = 37\text{ A}$, $di/dt = 100\text{ A}/\mu\text{s}$, $V_{DD} = 60\text{ V}$ (see Figure 14. Test circuit for inductive load switching and diode recovery times)	-	125		ns
Q_{rr}	Reverse recovery charge		-	0.52		μC
I_{RRM}	Reverse recovery current		-	7.5		A
t_{rr}	Reverse recovery time	$I_{SD} = 37\text{ A}$, $di/dt = 100\text{ A}/\mu\text{s}$, $V_{DD} = 60\text{ V}$, $T_J = 150\text{ }^\circ\text{C}$ (see Figure 14. Test circuit for inductive load switching and diode recovery times)	-	260		ns
Q_{rr}	Reverse recovery charge		-	2.5		μC
I_{RRM}	Reverse recovery current		-	17		A

1. Pulse width is limited by safe operating area.
2. Pulsed: pulse duration = 300 μs , duty cycle 1.5%.

2.1 Electrical characteristics (curves)

Figure 1. Safe operating area

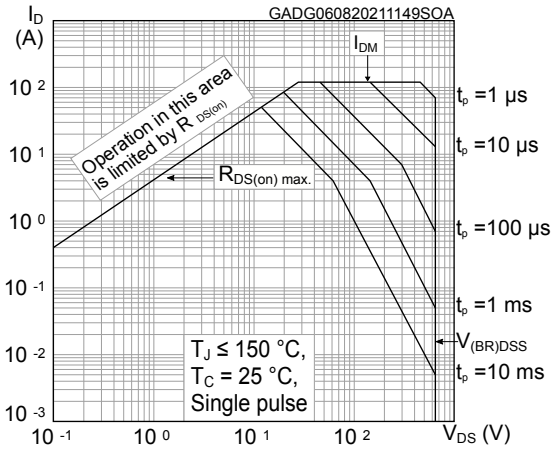

Figure 2. Maximum transient thermal impedance

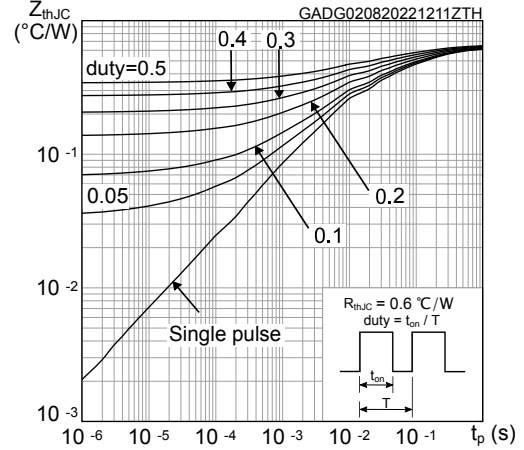

Figure 3. Typical output characteristics

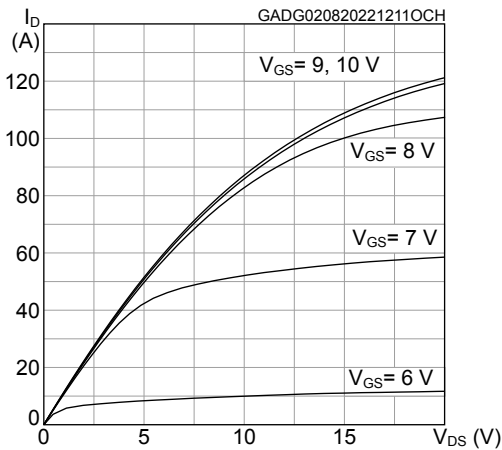

Figure 4. Typical transfer characteristics

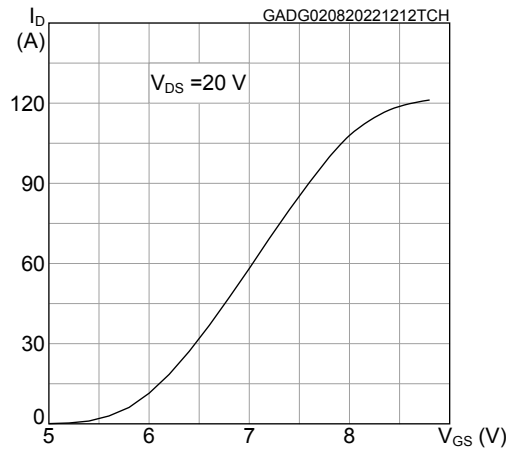

Figure 5. Typical drain-source on-resistance

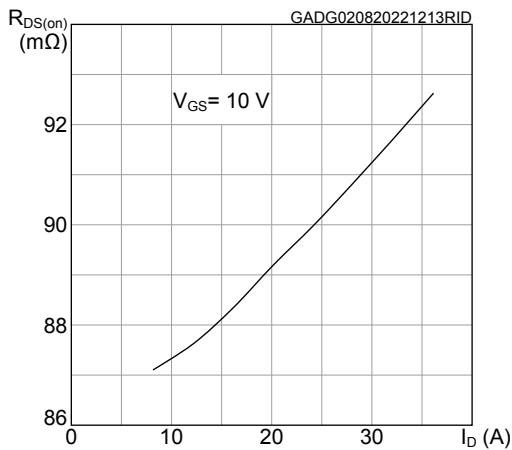

Figure 6. Typical gate charge characteristics

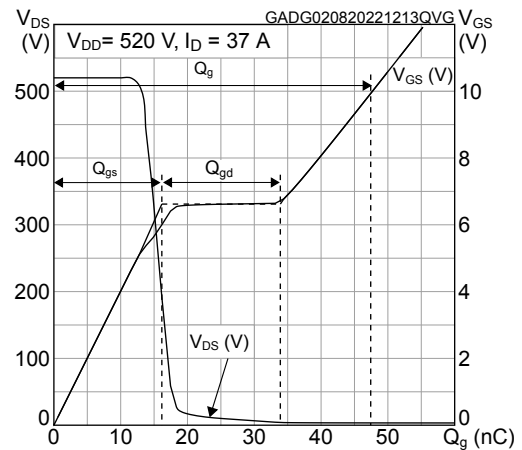

Figure 7. Typical capacitance characteristics

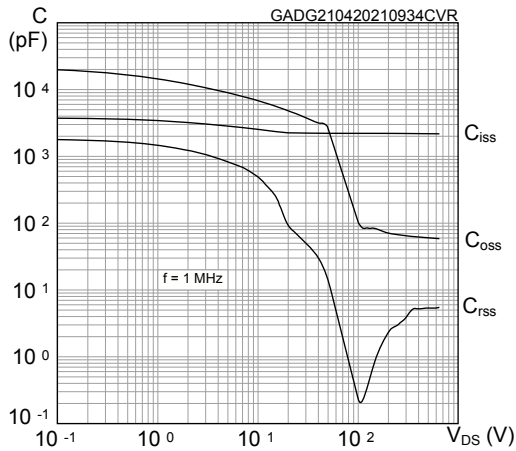

Figure 8. Normalized gate threshold vs temperature

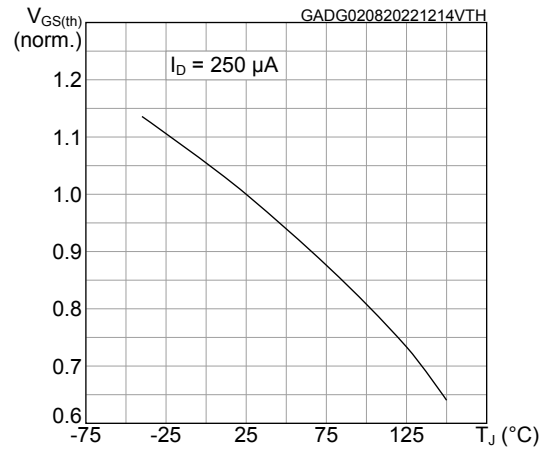

Figure 9. Normalized on-resistance vs temperature

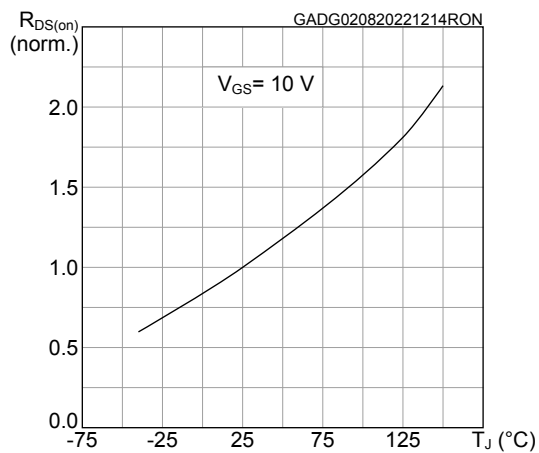

Figure 10. Normalized breakdown voltage vs temperature

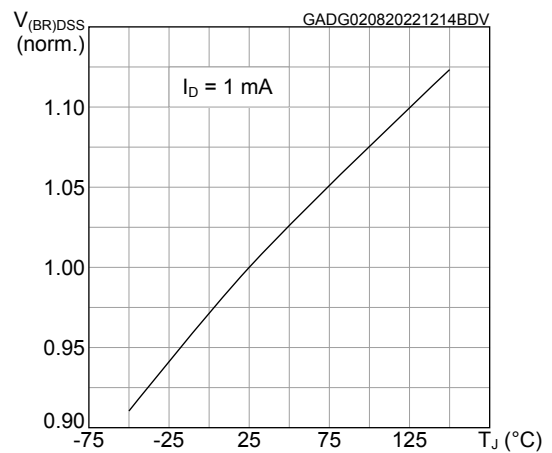
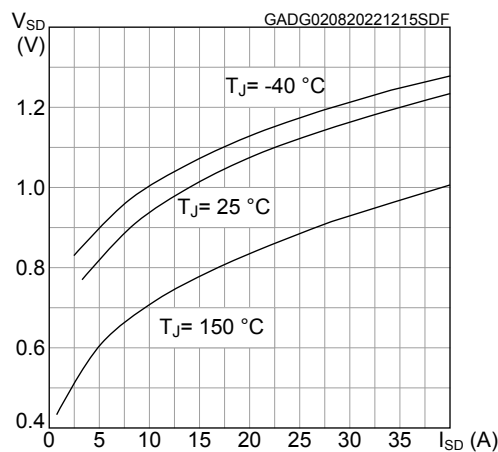
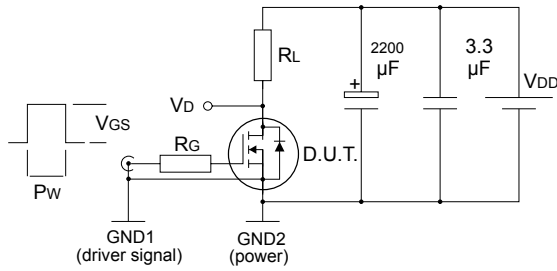

Figure 11. Typical reverse diode forward characteristics



3 Test circuits

Figure 12. Switching times test circuit for resistive load

AM15855v1

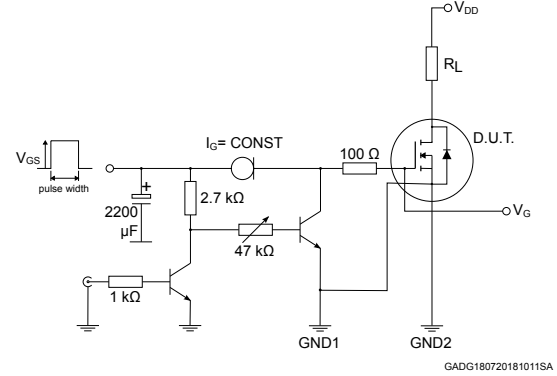
Figure 13. Test circuit for gate charge behavior

GADG180720181011SA

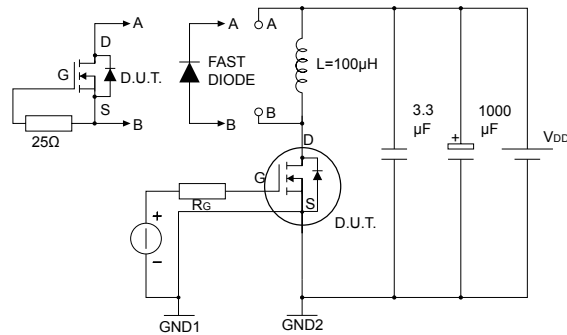
Figure 14. Test circuit for inductive load switching and diode recovery times

AM15857v1

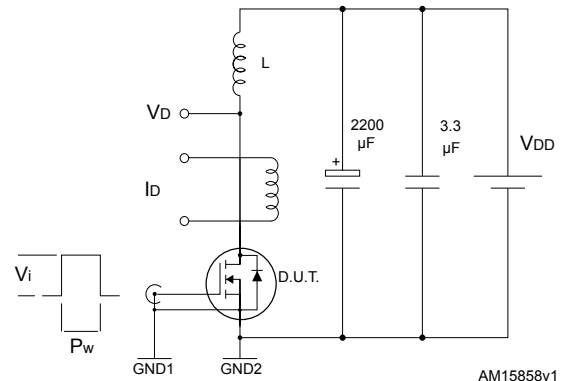
Figure 15. Unclamped inductive load test circuit

AM15858v1

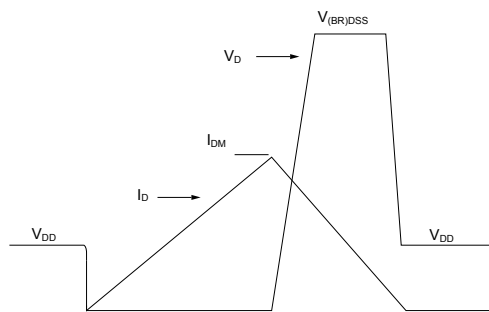
Figure 16. Unclamped inductive waveform

AM01472v1

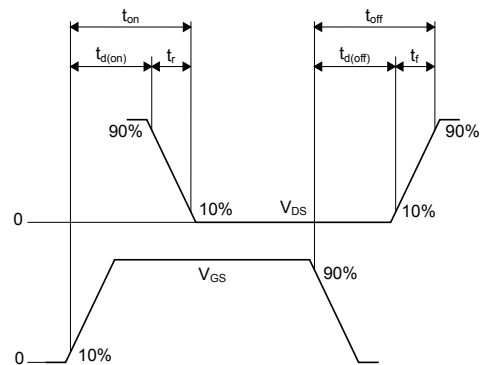
Figure 17. Switching time waveform

AM01473v1

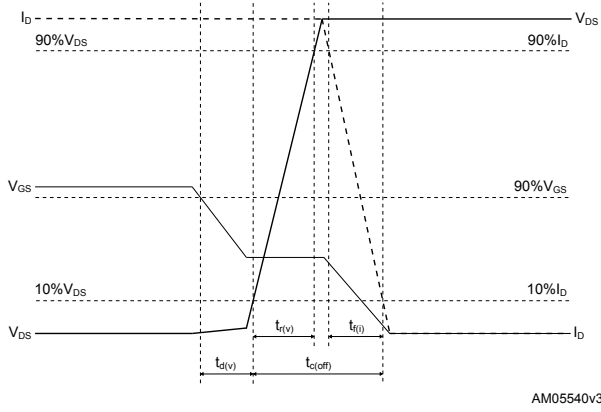
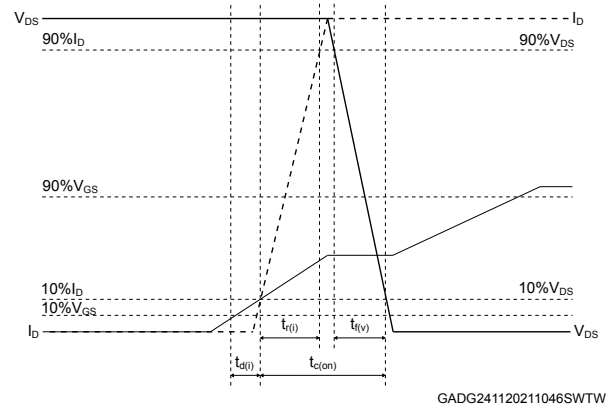
Figure 18. Turn-off switching time waveform on inductive load

Figure 19. Turn-on switching time waveform on inductive load

4 Package information

In order to meet environmental requirements, ST offers these devices in different grades of **ECOPACK** packages, depending on their level of environmental compliance. ECOPACK specifications, grade definitions and product status are available at: www.st.com. ECOPACK is an ST trademark.

4.1 ACEPACK SMIT package information

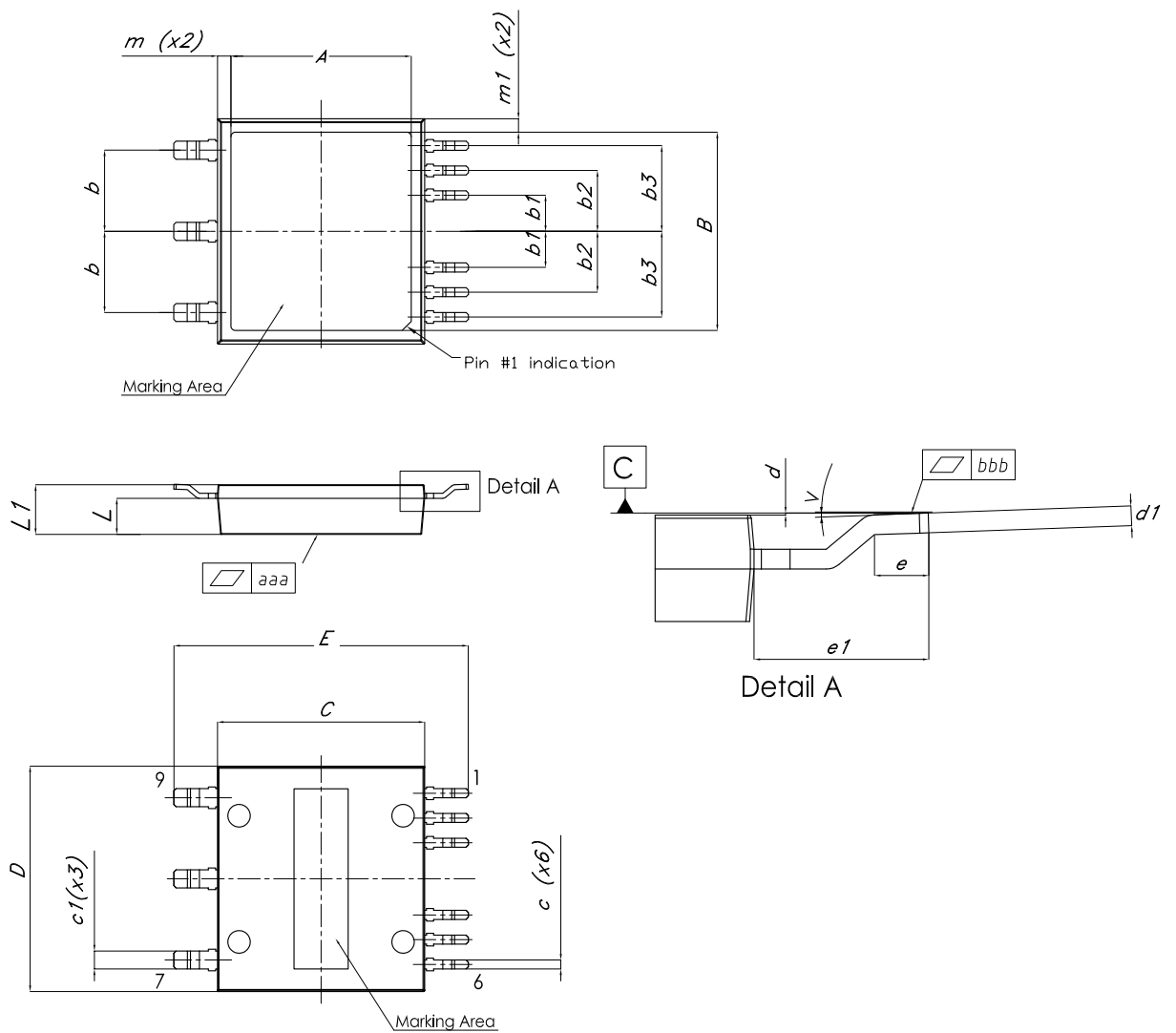
Figure 20. ACEPACK SMIT package outline



DM00447519_Rev.6

Table 9. ACEPACK SMIT package mechanical data

Dim.	mm		
	Min.	Typ.	Max.
A	19.50	20.00	20.50
B	21.50	22.00	22.50
C	22.80	23.00	23.20
D	24.80	25.00	25.20
E	32.20	32.70	33.20
b		9.00	
b1		4.00	
b2		6.75	
b3		9.50	
c	0.95	1.00	1.10
c1	1.95	2.00	2.10
d	0.00		0.15
d1	0.45	0.55	0.65
e	1.30	1.50	1.70
e1	4.65	4.85	5.05
L	3.95	4.00	4.05
L1	5.40	5.50	5.60
m	1.30	1.50	1.80
m1	1.30	1.50	1.80
V	0°	2°	4°
aaa	0.01		0.05
bbb	0.00		0.10

Figure 21. ACEPACK SMIT recommended footprint

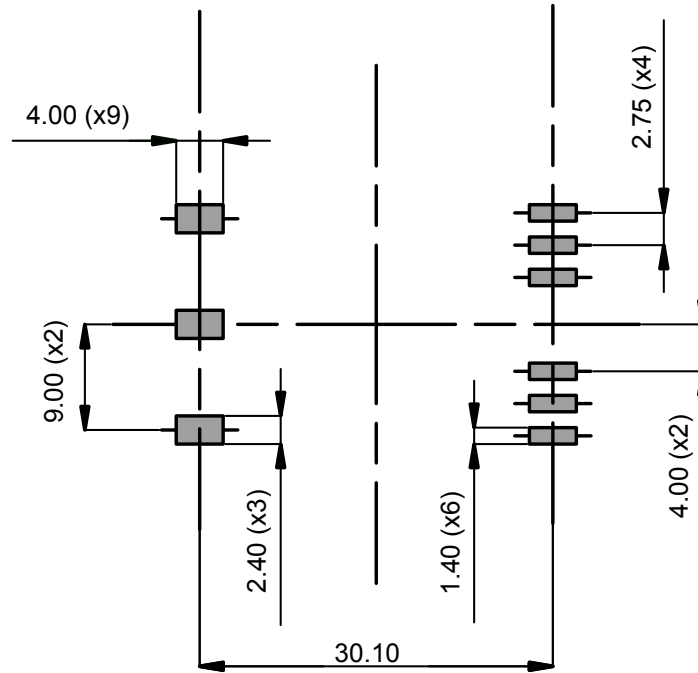

DM00447519_FP_Rev.6

Note: Dimensions in mm.

Figure 22. ACEPACK SMIT marking orientation vs pinout

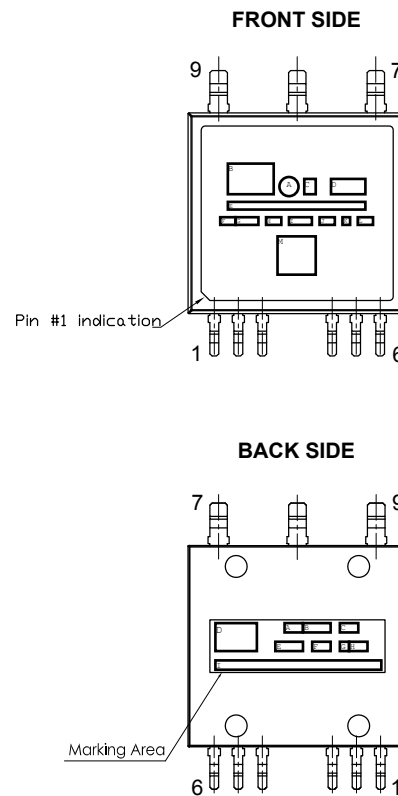

DM00447519_MO_Rev.6

Revision history

Table 10. Document revision history

Date	Revision	Changes
03-Aug-2022	1	First release.
03-Oct-2022	2	Updated Table 1. Absolute maximum ratings. Updated Table 3. Avalanche characteristics. Updated Table 4. On/off states. Updated Table 5. Dynamic characteristics. Updated Table 7. Switching characteristics (inductive load). Updated Table 8. Source-drain diode. Updated Figure 1. Safe operating area. Updated Figure 6. Typical gate charge characteristics. Minor text changes.

Contents

1	Electrical ratings	2
2	Electrical characteristics	3
2.1	Electrical characteristics (curves)	5
3	Test circuits	7
4	Package information	9
4.1	ACEPACK SMIT package information	9
	Revision history	12

IMPORTANT NOTICE – READ CAREFULLY

STMicroelectronics NV and its subsidiaries (“ST”) reserve the right to make changes, corrections, enhancements, modifications, and improvements to ST products and/or to this document at any time without notice. Purchasers should obtain the latest relevant information on ST products before placing orders. ST products are sold pursuant to ST’s terms and conditions of sale in place at the time of order acknowledgment.

Purchasers are solely responsible for the choice, selection, and use of ST products and ST assumes no liability for application assistance or the design of purchasers’ products.

No license, express or implied, to any intellectual property right is granted by ST herein.

Resale of ST products with provisions different from the information set forth herein shall void any warranty granted by ST for such product.

ST and the ST logo are trademarks of ST. For additional information about ST trademarks, refer to www.st.com/trademarks. All other product or service names are the property of their respective owners.

Information in this document supersedes and replaces information previously supplied in any prior versions of this document.

© 2022 STMicroelectronics – All rights reserved