

THE INFORMATION CONTAINED IN THIS DRAWING IS THE SOLE PROPERTY OF L-COM, INC. ANY REPRODUCTION IN PART OR WHOLE WITHOUT THE WRITTEN PERMISSION OF L-COM, INC. IS PROHIBITED.

REVISIONS			
REV	DESCRIPTION	DATE	APPROVED
A	INITIAL RELEASE	01/06/2014	D.GRIFFIN
B	ECN 11790: CORRECT OPERATING TEMPERATURE TO -10 TO +70°C	04/13/2022	D.REBECK

PART NUMBER	LENGTH	
	INCHES	MM
AL-ECF504-AA12	12.0	[304.8]
AL-ECF504-AA24	24.0	[609.6]
AL-ECF504-AA36	36.0	[914.4]
AL-ECF504-AA48	48.0	[1219.2]
AL-ECF504-AA72	72.0	[1828.8]

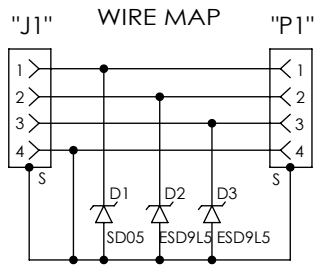
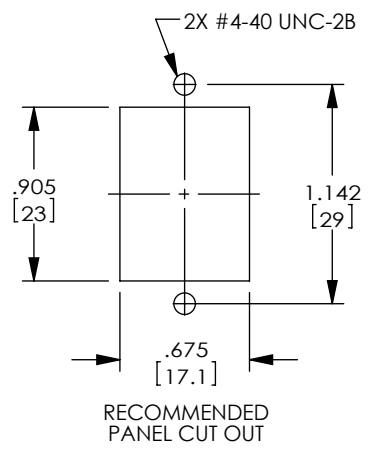
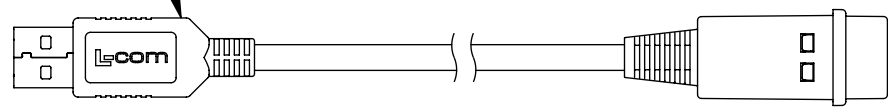
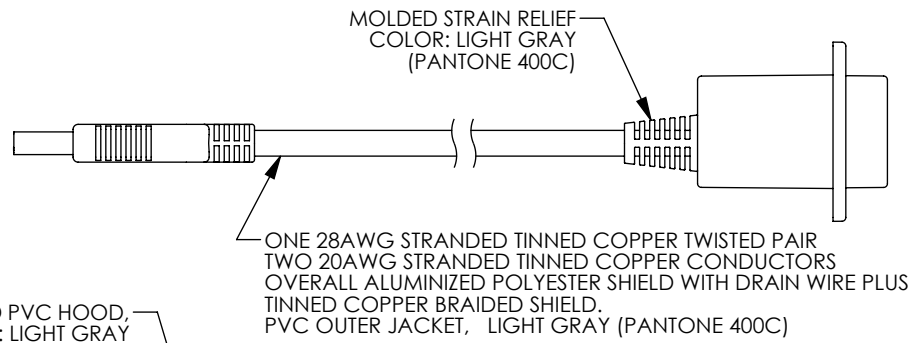
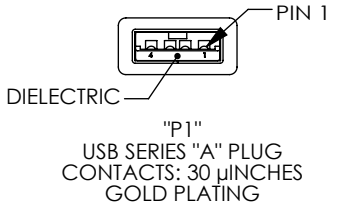
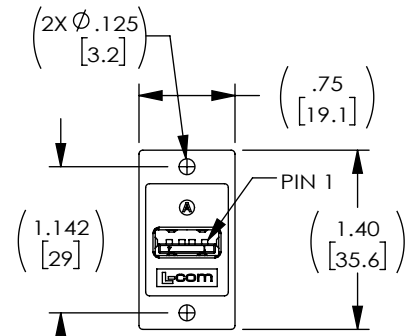
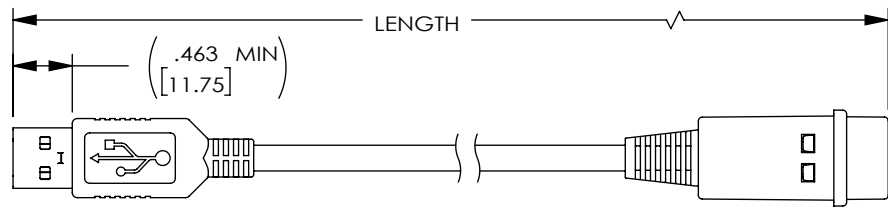

NOTES:

MATERIAL:
COUPLER HOUSING: ABS, UL94V-0.
CONNECTOR INSULATORS: WHITE PBT WITH GLASS FIBER.
PCB: EPOXY GLASS FP-4, 94V-0 FLAMMABILITY RATING.

FINISH:
COUPLER HOUSING: CHROME.
CONNECTOR CONTACTS: GOLD, 30μ INCHES.
CONNECTOR SHELLS: NICKEL.

ELECTRICAL:
DATA LINE CLAMPING VOLTAGE: 5.4V.
POWER LINE CLAMPING VOLTAGE: 6.5V.

ENVIRONMENTAL:
OPERATING TEMPERATURE: -10°C TO +70°C.

MISCELLANEOUS:
COUPLER SHALL BE TESTED FOR CONTINUITY.
COUPLER SHALL BE INDIVIDUALLY PACKAGED IN
ACCORDANCE WITH L-COM PACKAGING SPEC PS-0031.

UNLESS OTHERWISE SPECIFIED, DIMENSIONS ARE IN INCHES [mm] OVERALL CABLE LENGTH TOLERANCE: ≤12 [305] = +1 [25] / -0 >12 [305] ≤60 [1524] = +2 [51] / -0 >60 [1524] ≤120 [3048] = +4 [102] / -0 >120 [3048] ≤300 [7620] = +6 [152] / -0 >300 [7620] = +5% / -0 ALL OTHER DIMENSIONAL TOLERANCES: .X = ± .2 [5] FRACTIONS ± 1/32 .XX = ± .02 [.5] ANGLES ± 1° .XXX = ± .005 [1.3]	APPROVALS	DATE	 50 High Street, West Mill, North Andover, MA 01845 USA. Phone: 1.800.341.5266 1.978.682.6936			
	DRAWN BY BPUCHASKI	10/30/2013		CATEGORY LIGHTNING PROTECTORS		
	CHECKED BY P.PESA	10/30/2013				
	APPROVED BY P.PESA	10/30/2013		PRODUCT DESCRIPTION LP, USB 2.0 A/A W/ PIGTAIL		
THIRD-ANGLE PROJECTION 	CONFIGURATION DETAILS OF UNDIMENSIONED FEATURES MAY VARY	COLOR VARIATIONS MAY OCCUR	SIZE A	CAGE CODE 43321	DWG. NO. AL-ECF504-AAXX	REV. B
SCALE: NONE		CAD FILE: AL-ECF504-AAXX.SLDDRW		SHEET 1 OF 1		